

# FireCase

Frameless structural steel encasement system that provides up to 120 minutes fire protection



## FireCase

**FireCase** is a frameless structural steel encasement system that provides up to 120 minutes fire protection to a wide range of universal beam, column and joist sizes. Installation is quick and easy owing to the ability to fix Glasroc F FIRECASE boards to one another without the need for additional framing.

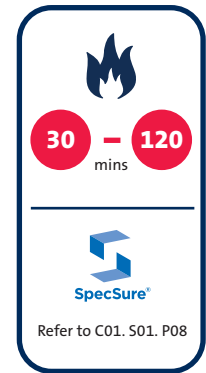

The Glasroc F FIRECASE lining provides a smooth, robust surface with no requirement to joint or apply a decorative treatment.

### Key benefits

- Frameless system that minimises the space needed to provide fire protection to structural steel
- Reduced installation time as Glasroc F FIRECASE boards can be screw-fixed to one another without the need for other components
- Build-programme flexibility and earlier installation as the inherent moisture resistance capability of Glasroc F FIRECASE means that installation of the FireCase system can commence before the building envelope is fully weather tight
- FireCase system is easy to inspect for continuity when compared to intumescent paint solutions, giving greater peace of mind both immediately after installation and during maintenance inspections
- Reduced waste and labour onsite as bespoke, pre-cut widths of Glasroc F FIRECASE are available (subject to minimum order quantity)
- High levels of acoustic insulation, in addition to excellent fire protection performance, can be maintained with appropriate detailing to the abutments between GypWall partition systems and FireCase steel encasements
- British Board of Agrément (BBA) approved (93/2935)

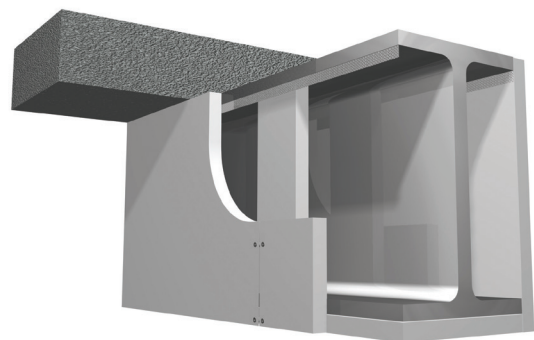
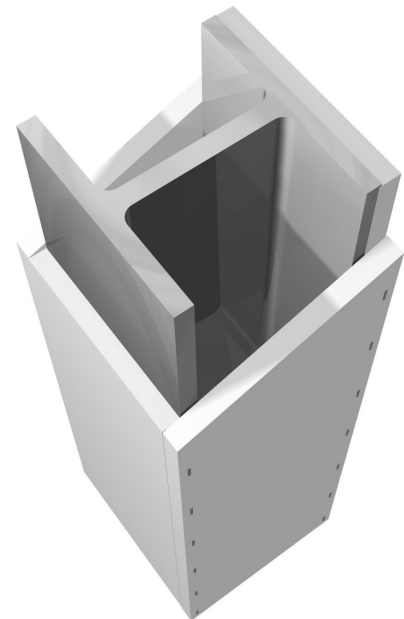

## Planning – key factors

FireCase steel encasement is suitable for protecting structural steel sections with a section factor  $A/V$  ( $H_p/A$ ) up to  $260\text{m}^{-1}$ , calculated on the basis of box protection to three or four sides as required. It will protect universal column and beam sections described in *BS 4: Part 1*, and many joist and castellated beam sections.

## Lining selection

Follow the procedure below to determine the thickness of cladding required:

### Option 1

Use tables 2 - 4 to select steel size and fire protection then read off the required board size.

### Option 2

- 1 Ascertain whether protection is required on three or four sides of the section
- 2 Find out what period of fire protection is required
- 3 Refer to the  $A/V$  ( $H_p/A$ ) tables 5 - 7. Locate the steel section to be protected, listed by its size and mass per metre, and read off the section factor  $A/V$
- 4 Refer to tables 8 - 11. Locate the  $A/V$  value on the vertical scale on the appropriate table. Read across the chart to the column relating to the period of fire protection required and read off the designated thickness of the relevant cladding required to form the encasement
- 5 Select the type of board to be using the key below each table

For castellated sections and cellular beams please refer to the Association for Specialist Fire Protection publication, ASFP Yellow Book - 'Fire Protection for Structural Steel in buildings' for guidance, available to download from [asfp.org.uk](http://asfp.org.uk)

## Partition fixing

Partitions and wall linings may be fixed directly to the Glasroc F FIRECASE cladding as long as:

- 1 The fire resistance requirement of the partition is 60 minutes or less
- 2 There are no special requirements for pressure resistance, e.g. around lift shafts
- 3 There are no special loading requirements, i.e. Heavy Duty or Severe Duty as defined in recognised partition performance specifications (e.g. *BS 5234*)

► Refer to construction detail 9.

Where these criteria are not met, the partition framing must be suitably fixed to the structural steel section, through the Glasroc F FIRECASE cladding. Where the partition abuts the web of the structural steel, a suitable steel noggling must be provided.

► Refer to construction detail 10.

## Partition to structural steelwork junctions

When designing the layout of rooms requiring separation by sound insulating walls abutting structural steelwork, consideration should be given to the potential loss of sound insulation performance through the steelwork.

Figures 13 to 16 are example details relating to a typical scenario where a partition is specified against a requirement of  $R_w$  50dB. Although these details refer to structural steel column abutments, similar principles apply when abutting structural steel beams. We recommend that these details are checked by an Acoustic Consultant, in particular the performance via the flanking structure.

## Finishing

Glasroc F FIRECASE joints can be treated using Gyproc Joint Tape bedded in Gyproc Joint Cement. External angles / corners can be reinforced using Gyproc Drywall Metal Angle Bead bedded in Gyproc Joint Cement.

► Refer to C08. S03. P492 – Finishes, Jointing.

If a plaster finish is required, joints should be reinforced and Gyproc Finish Plaster applied.

► Refer to C08. S02. P486 – Finishes, Plaster skimming and C07. S02. P459 – Linings, Plaster systems.

Jointing and finishing is not a requirement of meeting the specified fire resistance. Board joints / abutments must be a flush fit.



## Important information

- Where steel section web dimensions exceed 600mm, additional support will be required for the cladding. Please contact the Gyproc Technical Department for guidance.
- All joints should be staggered by minimum of 600mm.

**Table 1 – Specialist board fixings**

Board thickness (mm)	Minimum fixing length	
	Board-to-board fixing	Board-to-metal fixing
15	40mm Glasroc F FIRECASE Screws	40mm Glasroc F FIRECASE Screws
20	50mm Glasroc F FIRECASE Screws	40mm Glasroc F FIRECASE Screws
25	58mm Glasroc F FIRECASE Screws	40mm Glasroc F FIRECASE Screws
30	70mm Glasroc F FIRECASE Screws	40mm Glasroc F FIRECASE Screws
15 + 20	40mm and 50mm Glasroc F FIRECASE Screws	40mm and 50mm Glasroc F FIRECASE Screws



### Important information

Where partitions abut a FireCase column or beam encasement and it is important to minimise the downgrade in acoustic performance, use either:

- Isover insulation within the web space
  - ▶ Refer to construction details 14 and 15; or
- Additional framing, Isover insulation and Gyproc plasterboard lining
  - ▶ Refer to construction detail 16

## FireCase design (continued)

For details of when  
to specify fire  
resistance using BS  
▶ Refer to C02. S01. P18



**Table 2 – 550°C chart to BS 476: Part 20 for selecting the required Glasroc F FIRECASE lining thickness for universal beam sizes**

Universal beam serial size of steel (mm x mm x kg/m)			Total Glasroc F FIRECASE board thickness (mm) to achieve fire resistance below <sup>1</sup>							
D	B	Mass/metre	3 sided encasement				4 sided encasement			
			30 min	60 min	90 min	120 min	30 min	60 min	90 min	120 min
1016	305	487	15	15	15	15	15	15	15	15
	305	438	15	15	15	15	15	15	15	15
	305	393	15	15	15	15	15	15	15	15
	305	349	15	15	15	15	15	15	15	15
	305	314	15	15	15	15	15	15	15	15
	305	272	15	15	15	15	15	15	15	20
	305	249	15	15	15	20	15	15	15	20
	305	222	15	15	15	20	15	15	15	20
914	419	388	15	15	15	15	15	15	15	15
	419	343	15	15	15	15	15	15	15	15
	305	289	15	15	15	15	15	15	15	15
	305	253	15	15	15	15	15	15	15	20
	305	224	15	15	15	20	15	15	15	20
	305	201	15	15	15	20	15	15	15	25
838	292	226	15	15	15	20	15	15	15	20
	292	194	15	15	15	20	15	15	15	20
	292	176	15	15	15	20	15	15	15	25
762	267	197	15	15	15	20	15	15	15	20
	267	173	15	15	15	20	15	15	15	25
	267	147	15	15	15	25	15	15	20	30
	267	134	15	15	15	25	15	15	20	30
686	254	170	15	15	15	20	15	15	15	20
	254	152	15	15	15	20	15	15	15	25
	254	140	15	15	15	20	15	15	15	25
	224	125	15	15	15	25	15	15	20	30
610	305	238	15	15	15	15	15	15	15	15
	305	179	15	15	15	20	15	15	15	20
	305	149	15	15	15	20	15	15	15	25
	229	140	15	15	15	20	15	15	15	25
	229	125	15	15	15	20	15	15	15	25
	229	113	15	15	15	25	15	15	20	30
	229	101	15	15	20	30	15	15	20	30
	178	100	15	15	20	30	15	15	20	30
	178	92	15	15	20	30	15	15	20	30
	178	82	15	15	20	30	15	15	20	30
	533	312	273	15	15	15	15	15	15	15
312		219	15	15	15	15	15	15	15	15
312		182	15	15	15	15	15	15	15	20
312		151	15	15	15	20	15	15	15	20
210		138	15	15	15	20	15	15	15	20
210		122	15	15	15	20	15	15	15	25
210		109	15	15	15	25	15	15	20	30
210		101	15	15	15	25	15	15	20	30
210		92	15	15	20	30	15	15	20	30
210		82	15	15	20	30	15	15	20	30
165		85	15	15	20	30	15	15	20	30
165		75	15	15	20	30	15	15	20	30
165		66	15	15	20	30	15	15	20	30

<sup>1</sup>Glasroc F FIRECASE thickness combinations:

- 15mm = 1 x 15mm
- 20mm = 1 x 20mm
- 25mm = 1 x 25mm
- 30mm = 1 x 30mm
- 35mm = 1 x 15mm + 1 x 20mm

System references: D120001 (screwed system)

Beam/column/joist dimension orientation:

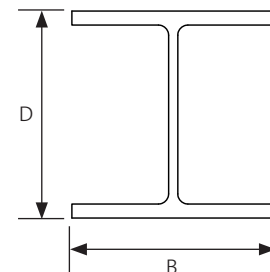



Table 2 (continued) – 550°C chart to BS 476: Part 20 for selecting the required Glasroc F FIRECASE lining thickness for universal beam sizes

Universal beam serial size of steel (mm x mm x kg/m)			Total Glasroc F FIRECASE board thickness (mm) to achieve fire resistance below <sup>1</sup>							
D	B	Mass/metre	3 sided encasement				4 sided encasement			
			30 min	60 min	90 min	120 min	30 min	60 min	90 min	120 min
457	191	161	15	15	15	15	15	15	15	15
	191	133	15	15	15	20	15	15	15	20
	191	106	15	15	15	20	15	15	15	25
	191	98	15	15	15	20	15	15	15	25
	191	89	15	15	15	25	15	15	20	30
	191	82	15	15	15	25	15	15	20	30
	191	74	15	15	20	30	15	15	20	30
	191	67	15	15	20	30	15	15	20	30
	152	82	15	15	15	25	15	15	20	30
	152	74	15	15	20	30	15	15	20	30
	152	67	15	15	20	30	15	15	20	30
	152	60	15	15	20	30	15	15	20	30
	152	52	15	15	20	30	15	15	20	30
	406	178	85	15	15	15	25	15	15	20
178		74	15	15	15	25	15	15	20	30
178		67	15	15	20	30	15	15	20	30
178		60	15	15	20	30	15	15	20	30
178		54	15	15	20	30	15	15	20	30
140		53	15	15	20	30	15	15	20	30
140		46	15	15	20	30	15	15	25	30
140		39	15	15	25	30	15	15	25	30
356	171	67	15	15	15	25	15	15	20	30
	171	57	15	15	20	30	15	15	20	30
	171	51	15	15	20	30	15	15	20	30
	171	45	15	15	20	30	15	15	20	30
	127	39	15	15	20	30	15	15	25	30
	127	33	15	15	25	30	15	15	25	30
305	165	54	15	15	20	30	15	15	20	30
	165	46	15	15	20	30	15	15	20	30
	165	40	15	15	20	30	15	15	25	30
	127	48	15	15	20	30	15	15	20	30
	127	42	15	15	20	30	15	15	20	30
	127	37	15	15	20	30	15	15	20	30
	102	33	15	15	20	30	15	15	25	30
	102	28	15	15	25	30	15	15	25	30
	102	25	15	15	25	30	15	15	25	35
	254	146	43	15	15	20	30	15	15	20
146		37	15	15	20	30	15	15	20	30
146		31	15	15	20	30	15	15	25	30
102		28	15	15	20	30	15	15	25	30
102		25	15	15	25	30	15	15	25	30
102		22	15	15	25	30	15	15	25	35
203	133	30	15	15	20	30	15	15	20	30
	133	25	15	15	20	30	15	15	25	30
	102	23	15	15	20	30	15	15	25	30
178	102	19	15	15	25	30	15	15	25	30
152	89	16	15	15	25	30	15	15	25	30
127	76	13	15	15	25	30	15	15	25	30

<sup>1</sup>Glasroc F FIRECASE thickness combinations:

- 15mm = 1 x 15mm
- 20mm = 1 x 20mm
- 25mm = 1 x 25mm
- 30mm = 1 x 30mm
- 35mm = 1 x 15mm + 1 x 20mm

Beam/column/joist dimension orientation:

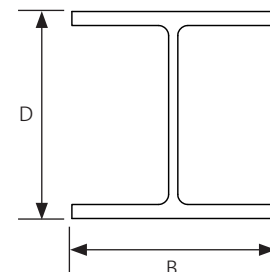

System references: D120001 (screwed system)



Table 3 – 550°C chart to BS 476: Part 20 for selecting the required Glasroc F FIRECASE lining thickness for universal column sizes

Universal column serial size of steel (mm x mm x kg/m)			Total Glasroc F FIRECASE board thickness (mm) to achieve fire resistance below <sup>1</sup>							
			3 sided encasement				4 sided encasement			
D	B	Mass/metre	30 min	60 min	90 min	120 min	30 min	60 min	90 min	120 min
356	406	634	15	15	15	15	15	15	15	15
	406	551	15	15	15	15	15	15	15	15
	406	467	15	15	15	15	15	15	15	15
	406	393	15	15	15	15	15	15	15	15
	406	340	15	15	15	15	15	15	15	15
	406	287	15	15	15	15	15	15	15	15
	406	235	15	15	15	15	15	15	15	15
	368	202	15	15	15	15	15	15	15	15
	368	177	15	15	15	15	15	15	15	15
	368	153	15	15	15	15	15	15	15	20
368	129	15	15	15	15	15	15	15	20	
305	305	283	15	15	15	15	15	15	15	15
	305	240	15	15	15	15	15	15	15	15
	305	198	15	15	15	15	15	15	15	15
	305	158	15	15	15	15	15	15	15	15
	305	137	15	15	15	15	15	15	15	20
	305	118	15	15	15	15	15	15	15	20
	305	97	15	15	15	20	15	15	15	25
254	254	167	15	15	15	15	15	15	15	15
	254	132	15	15	15	15	15	15	15	15
	254	107	15	15	15	15	15	15	15	20
	254	89	15	15	15	20	15	15	15	20
	254	73	15	15	15	20	15	15	20	30
203	203	127	15	15	15	15	15	15	15	15
	203	113	15	15	15	15	15	15	15	15
	203	100	15	15	15	15	15	15	15	20
	203	86	15	15	15	15	15	15	15	20
	203	71	15	15	15	20	15	15	15	25
	203	60	15	15	15	20	15	15	20	30
	203	52	15	15	15	25	15	15	20	30
	203	46	15	15	15	25	15	15	20	30
	152	152	51	15	15	15	20	15	15	15
152		44	15	15	15	20	15	15	20	30
152		37	15	15	15	25	15	15	20	30
152		30	15	15	20	30	15	15	20	30
152		23	15	15	20	30	15	15	25	30

<sup>1</sup>Glasroc F FIRECASE thickness combinations:

- 15mm = 1 x 15mm
- 20mm = 1 x 20mm
- 25mm = 1 x 25mm
- 30mm = 1 x 30mm
- 35mm = 1 x 15mm + 1 x 20mm

Beam/column/joist dimension orientation:

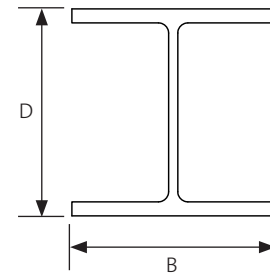

System references: D120001 (screwed system)



Table 4 – 550°C chart to BS 476: Part 20 for selecting the required Glasroc F FIRECASE lining thickness for universal joist sizes

Universal joist serial size of steel (mm x mm x kg/m)			Total Gyproc F FIRECASE board thickness (mm) to achieve fire resistance below <sup>1</sup>							
			3 sided encasements				4 sided encasements			
D	B	Mass/metre	30 min	60 min	90 min	120 min	30 min	60 min	90 min	120 min
254	203	82	15	15	15	20	15	15	15	25
	114	37	15	15	20	30	15	15	20	30
203	152	52	15	15	15	20	15	15	20	25
	102	25	15	15	20	30	15	15	25	30
178	102	22	15	15	20	30	15	15	25	30
152	127	37	15	15	15	30	15	15	20	30
	89	17	15	15	25	30	15	15	25	30
	76	18	15	15	20	30	15	15	25	30
127	114	30	15	15	15	25	15	15	20	30
	114	27	15	15	20	30	15	15	20	30
	76	16	15	15	20	30	15	15	25	30
	76	13	15	15	25	30	15	15	25	30
114	114	27	15	15	15	25	15	15	20	30
102	102	23	15	15	20	25	15	15	20	30
	64	10	15	15	25					
	44	7	15	15	25					
89	89	19	15	15	20	25	15	15	20	30
76	76	15	15	15	20	30	15	15	20	30
	76	13	15	15	20	30	15	15	25	30

<sup>1</sup> Glasroc F FIRECASE thickness combinations

- 15mm = 1 x 15mm
- 20mm = 1 x 20mm
- 25mm = 1 x 25mm
- 30mm = 1 x 30mm
- 35mm = 1 x 15mm + 1 x 20mm

- protection not possible

System references: D120001  
(screwed system)

Beam/column/joist dimension orientation:

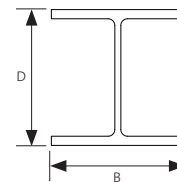

Table 5 – Section factor A/V (Hp/A) of universal beams

Universal beams serial size of steel (mm x mm x kg/m)			A / V Values		
D	B	Mass/metre	3 sided encasement	4 sided encasement	
1016	305	487	40	45	
	305	438	40	50	
	305	393	45	55	
	305	349	50	60	
	305	314	55	65	
	305	272	65	75	
	305	249	70	80	
	305	222	80	90	
914	419	388	45	55	
	419	343	50	60	
	305	289	60	65	
	305	253	65	75	
	305	224	75	85	
	305	201	80	95	
838	292	226	70	80	
	292	194	80	90	
	292	176	90	100	
762	267	197	70	85	
	267	173	80	95	
	267	147	95	110	
	267	134	105	120	
686	254	170	75	90	
	254	152	85	95	
	254	140	90	105	
	254	125	100	115	
610	305	238	50	60	
	305	179	70	80	
	305	149	80	95	
	229	140	80	95	
	229	125	90	105	
	229	113	100	115	
	229	101	110	130	
	178	100	110	125	
	178	92	120	135	
	178	82	130	150	
	533	312	273	40	50
		312	219	50	65
		312	182	60	75
312		151	75	90	
210		138	75	85	
210		122	85	95	
210		109	95	110	
210		101	100	115	
210		92	110	125	
210		82	120	140	
165		85	115	130	
165		75	130	145	
165		66	145	165	

Table 5 (continued) – Section factor A/V (Hp/A) of universal beams

Universal beams serial size of steel (mm x mm x kg/m)			A / V Values		
D	B	Mass/metre	3 sided encasement	4 sided encasement	
457	191	161	60	65	
	191	133	70	80	
	191	106	85	100	
	191	98	90	105	
	191	89	100	115	
	191	82	105	125	
	191	74	115	135	
	191	67	130	150	
	152	82	105	120	
	152	74	115	130	
	152	67	125	145	
	152	60	140	160	
	152	52	160	180	
	406	178	85	95	110
		178	74	105	125
		178	67	115	140
178		60	130	155	
178		54	145	170	
140		53	140	160	
140		46	160	185	
140		39	190	215	
356		171	67	105	125
		171	57	120	145
	171	51	135	160	
	171	45	150	180	
	127	39	165	195	
	127	33	195	225	
	305	165	54	115	140
		165	46	135	160
165		40	150	185	
127		48	120	145	
127		42	140	160	
127		37	155	180	
102		33	175	200	
102		28	200	230	
102		25	225	255	
254		146	43	120	150
	146	37	140	170	
	146	31	165	200	
	102	28	175	200	
	102	25	190	225	
	102	22	220	255	
	203	133	30	145	180
		133	25	170	210
102		23	175	205	
178	102	19	190	230	
152	89	16	195	235	
127	76	13	200	245	

Beam/column/joist dimension orientation:

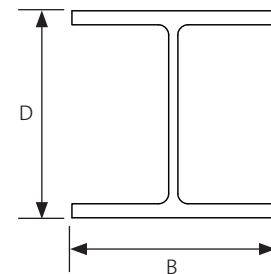

You may also be interested in...



Need 180mins fire protection? If so, consider the Gypliner ENCASE system.

► Refer to C03. S03. P99

Table 6 – Section factor A/V (Hp/A) of universal columns

Universal columns serial size of steel (mm x mm x kg/m)			A / V Values	
D	B	Mass/metre	3 sided encasement	4 sided encasement
			m <sup>-1</sup>	m <sup>-1</sup>
356	406	634	15	20
	406	551	20	25
	406	467	20	30
	406	393	25	35
	406	340	30	35
	406	287	30	45
	406	235	40	50
	368	202	45	60
	368	177	50	65
	368	153	55	75
	368	129	65	90
	305	305	283	30
305		240	35	45
305		198	40	50
305		158	50	65
305		137	55	70
305		118	60	85
305		97	75	100
254		254	167	40
	254	132	50	65
	254	107	60	75
	254	89	70	90
	254	73	80	110
203	203	127	45	55
	203	113	45	60
	203	100	55	70
	203	86	60	80
	203	71	70	95
	203	60	80	110
	203	52	95	125
	203	46	105	140
	152	152	51	75
152		44	85	115
152		37	100	135
152		30	120	160
152		23	155	210

Table 7 – Section factor A/V (Hp/A) of universal joist

Universal joist serial size of steel (mm x mm x kg/m)			A / V Values	
D	B	Mass/metre	3 sided encasement	4 sided encasement
			m <sup>-1</sup>	m <sup>-1</sup>
254	203	82	70	90
	114	37	130	155
203	152	52	85	105
	102	25	155	190
178	102	22	165	205
152	127	37	90	120
	89	17	180	220
	76	18	165	200
127	114	30	100	130
	114	27	110	140
	76	16	155	195
	76	13	195	240
	114	114	27	100
102	102	23	105	140
	64	10	215	270
	44	7	260	305
89	89	19	105	145
76	76	15	120	165
76	76	13	140	185

Beam/column/joist dimension orientation:

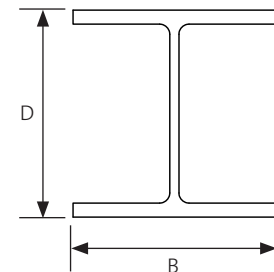

# FireCase performance



**Table 8**  
Solutions to satisfy the 550°C criteria when tested in accordance with *BS EN 13381-4: 2013* (four-sided columns only)  
▶ Refer to C02. S01. P18

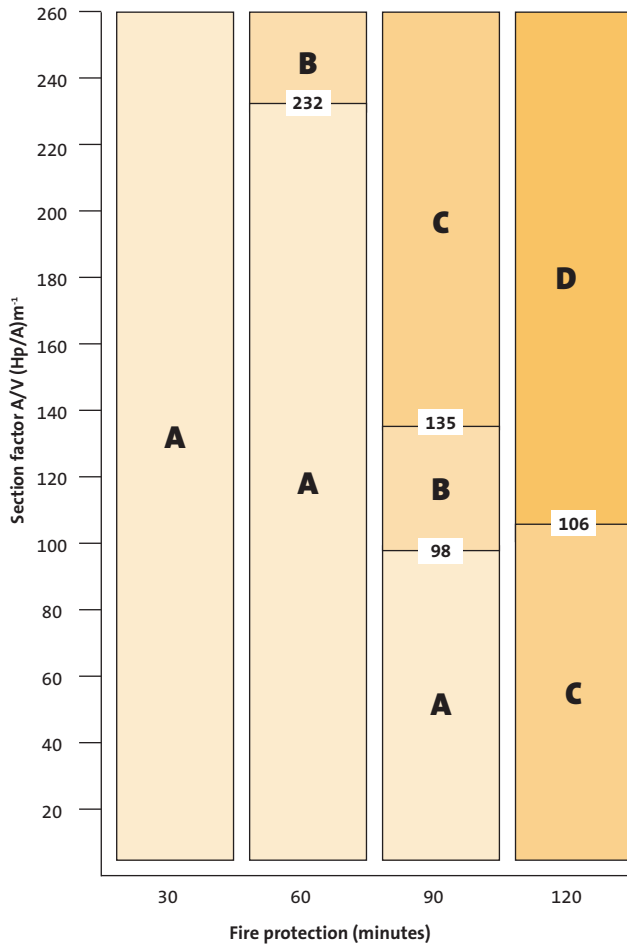

### Key - Thickness of Glasroc F FIRECASE required

A = 15mm  
B = 20mm  
C = 25mm  
D = 30mm

System references: D120001 (screwed system)



**Table 9**  
Solutions to satisfy the 550°C criteria when tested in accordance with *BS EN 13381-4: 2013* (three-sided beams only)  
▶ Refer to C02. S01. P18

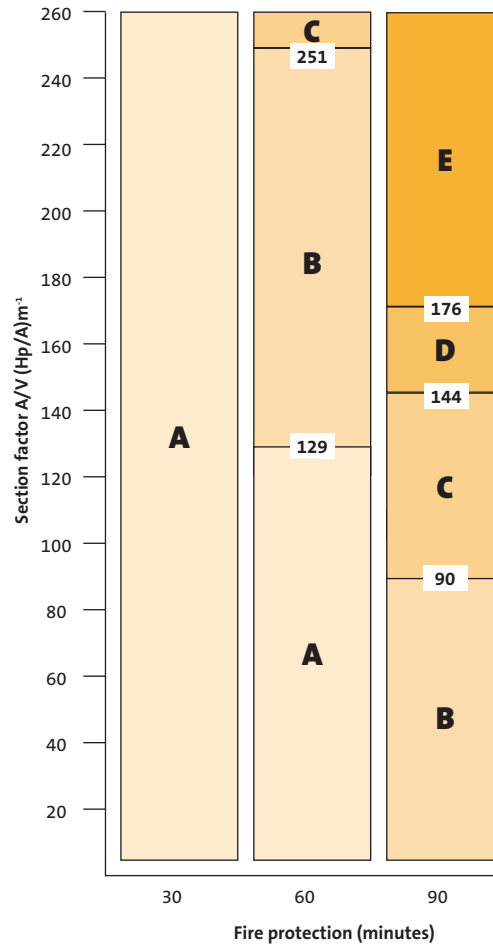

### Key - Thickness of Glasroc F FIRECASE required

A = 15mm  
B = 20mm  
C = 25mm  
D = 30mm  
E = 35mm (15 + 20mm)

System references: D120001 (screwed system)



**Table 10**  
Solutions to satisfy the 550°C criteria when tested in accordance with BS 476: Part 20: 1987 (beam and column encasement)  
▶ Refer to C02. S01. P18



**Table 11**  
Solutions to satisfy the 620°C criteria when tested in accordance with BS 476: Part 20: 1987 (beam and column encasement)  
▶ Refer to C02. S01. P18

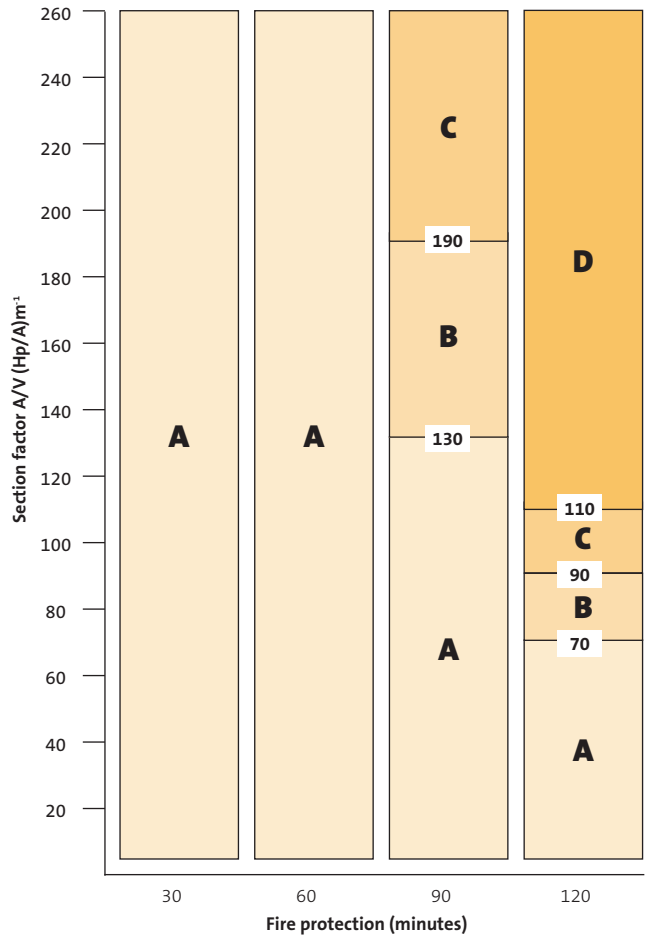
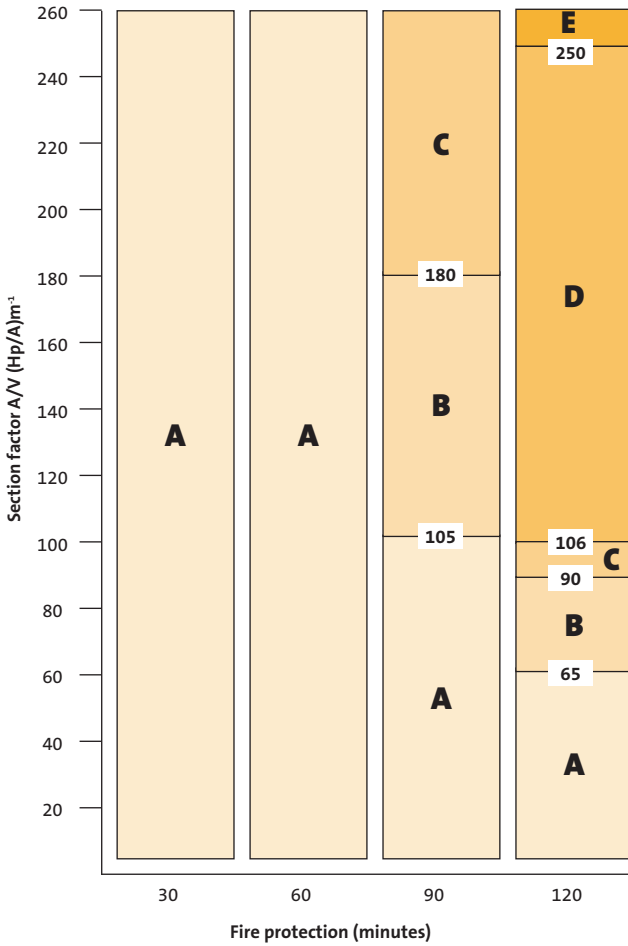

**Key - Thickness of Glasroc F FIRECASE required**

- A = 15mm
- B = 20mm
- C = 25mm
- D = 30mm
- E = 35mm (15mm + 20mm)

System references: D120001 (screwed system)

**Key - Thickness of Glasroc F FIRECASE required**

- A = 15mm
- B = 20mm
- C = 25mm
- D = 30mm

System references: D120001 (screwed system)

## FireCase construction details

1

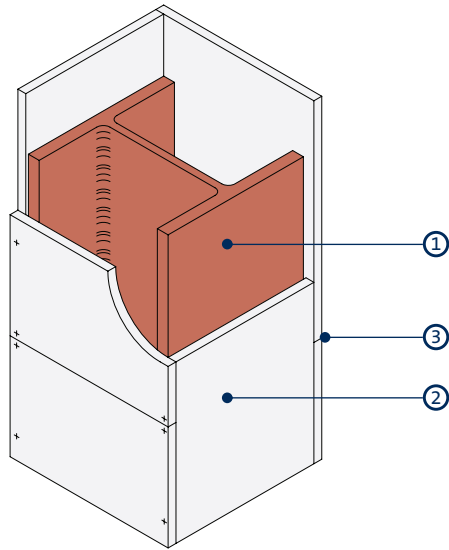

Four-sided column encasement for up to 120 minutes fire protection

2

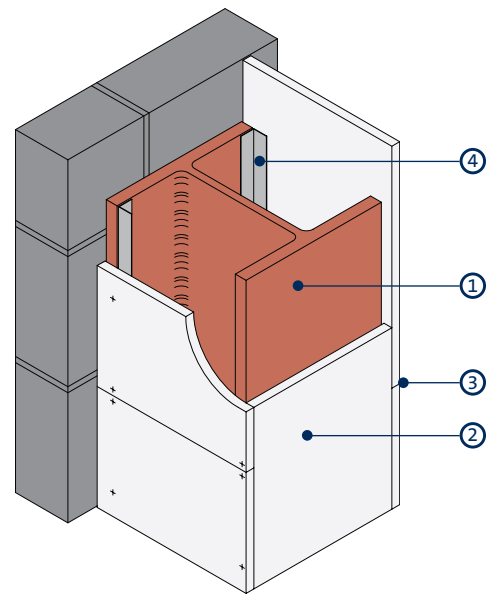

Three-sided column encasement incorporating steel angles for up to 120 minutes fire protection

3

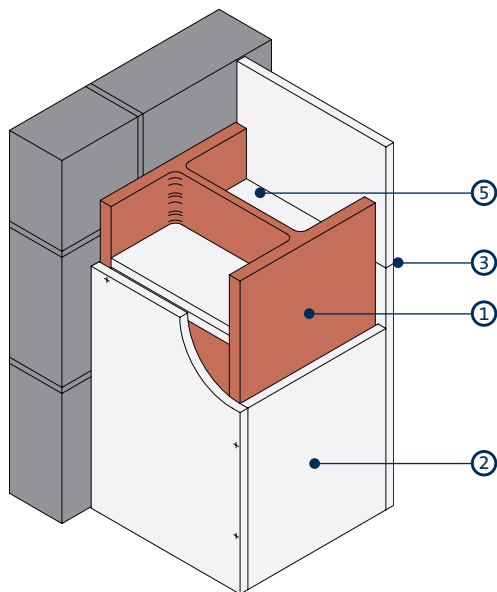

Three-sided column encasement incorporating Glasroc F FIRECASE soldiers for up to 90 minutes fire protection

4

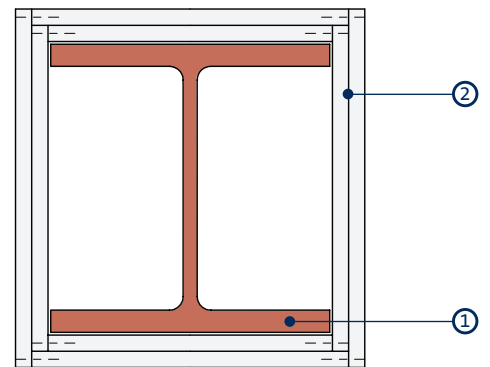

Four-sided column encasement for up to 120 minutes fire protection - double layer

- 1 Structural steel
- 2 Glasroc F FIRECASE fixed together with Glasroc F FIRECASE Screws at 150mm centres
- 3 Board joints staggered by minimum 600mm between adjacent sides

- 4 Gypframe FEA1 Steel Angle suitably fixed to column flange at 600mm centres
- 5 Glasroc F FIRECASE soldiers at 1200mm centres (two together at board joints)

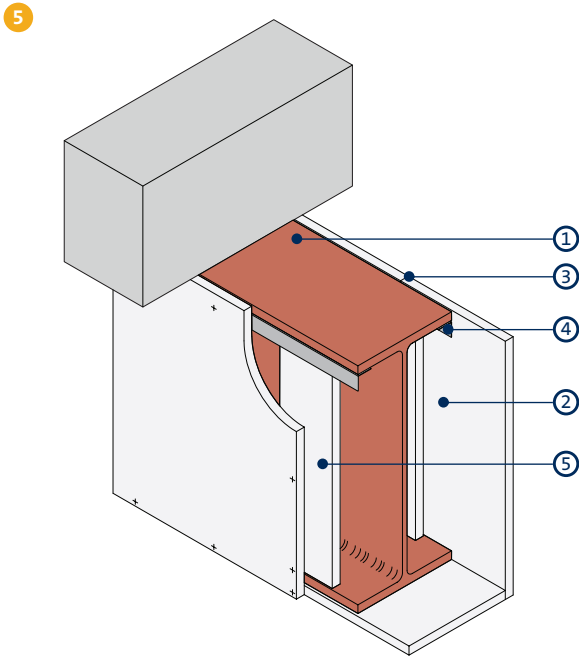

Three-sided beam encasement incorporating steel angles for up to 120 minutes fire protection

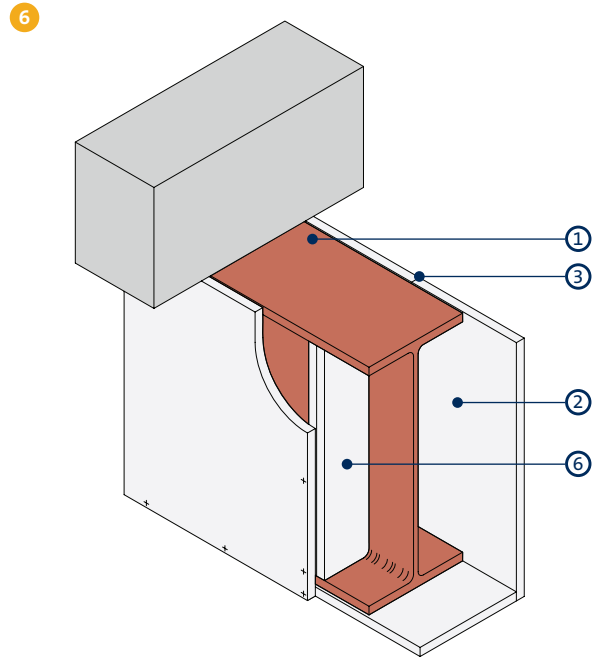

Three-sided beam encasement incorporating Glasroc F FIRECASE soldiers for up to 90 minutes fire protection

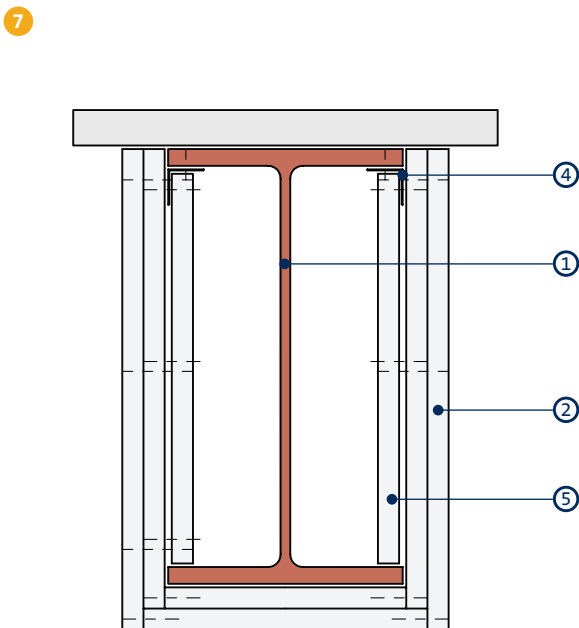

Three-sided beam encasement incorporating steel angles for up to 120 minutes fire protection - double layer

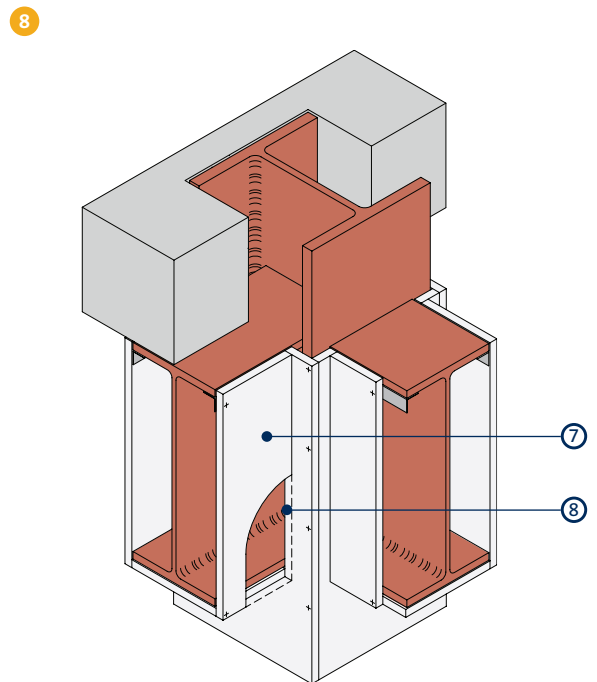

Column and beam encasement junction

- 1 Structural steel
- 2 Glasroc F FIRECASE fixed together with Glasroc F FIRECASE Screws at 150mm centres
- 3 Board joints staggered by minimum 600mm between adjacent sides
- 4 Gypframe FEA1 Steel Angle suitably fixed to beam flange at 600mm centres

- 5 60mm wide Glasroc F FIRECASE backing strip
- 6 Glasroc F FIRECASE soldiers at 1200mm centres (two together at board joints)
- 7 Beam encasement boards butted tight to column encasement
- 8 Column encasement boards cut around penetrations

## FireCase construction details (continued)

9

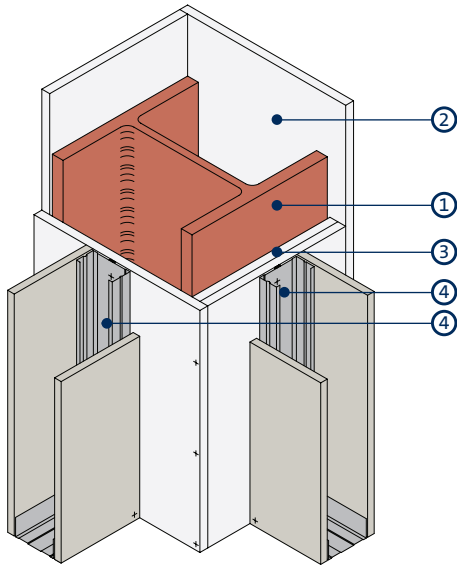

Column encasement and partition junction for partitions up to 60 minutes fire resistance and BS 5234 Light and Medium Duty

10

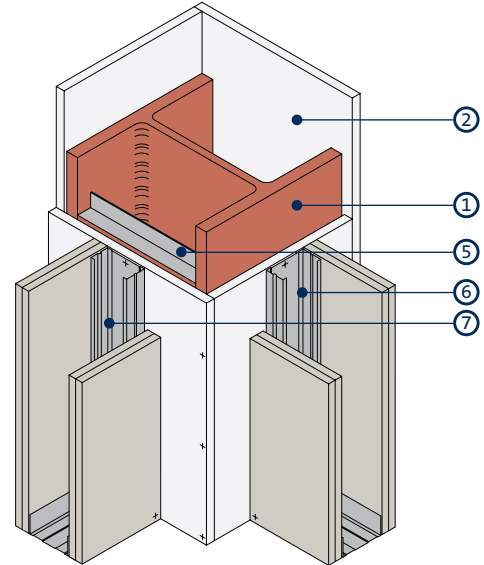

Column encasement and partition junction for partitions up to 120 minutes fire resistance and BS 5234 Heavy and Severe Duty

11

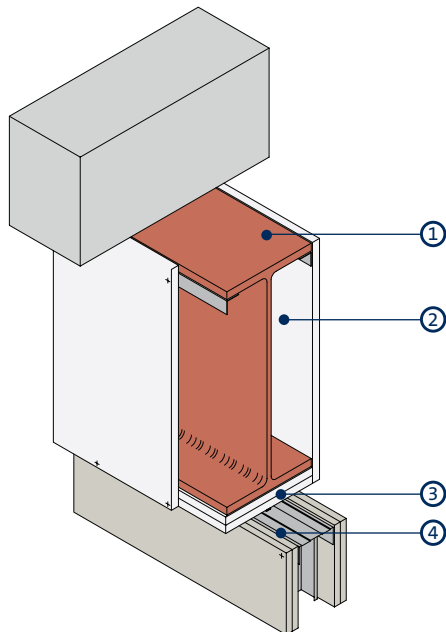

Beam encasement and partition junction for partitions up to 60 minutes fire resistance and BS 5234 Light and Medium Duty

12

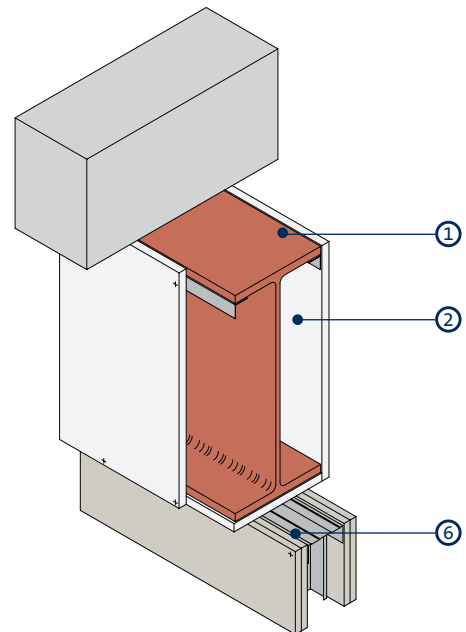

Beam encasement and partition junction for partitions up to 120 minutes fire resistance and BS 5234 Heavy and Severe Duty

- 1 Structural steel
- 2 FireCase encasement
- 3 Additional layer of Glasroc F FIRECASE forming packer to receive partition fixing
- 4 Gypframe 'C' Stud / Channel bonded to Glasroc F FIRECASE with continuous bead of Gyproc Sealant (two beads for studs wider than 75mm) and fixed with Gyproc Drywall Screws at 600mm centres (in two lines staggered by 300mm for studs wider than 75mm). Allow 24 hours before boarding

- 5 Suitable size Z-section (by others) fixed between column flanges at 600mm centres
- 6 Gypframe 'C' Stud / Channel suitably fixed through Glasroc F FIRECASE to structural steel at 600mm centres (in two lines staggered by 300mm for studs wider than 75mm)
- 7 Gypframe 'C' Stud suitably fixed through Glasroc F FIRECASE to Z-sections (in two lines for studs wider than 75mm)

**NB** To optimise acoustic performance install Isover insulation within the encasement void.

13

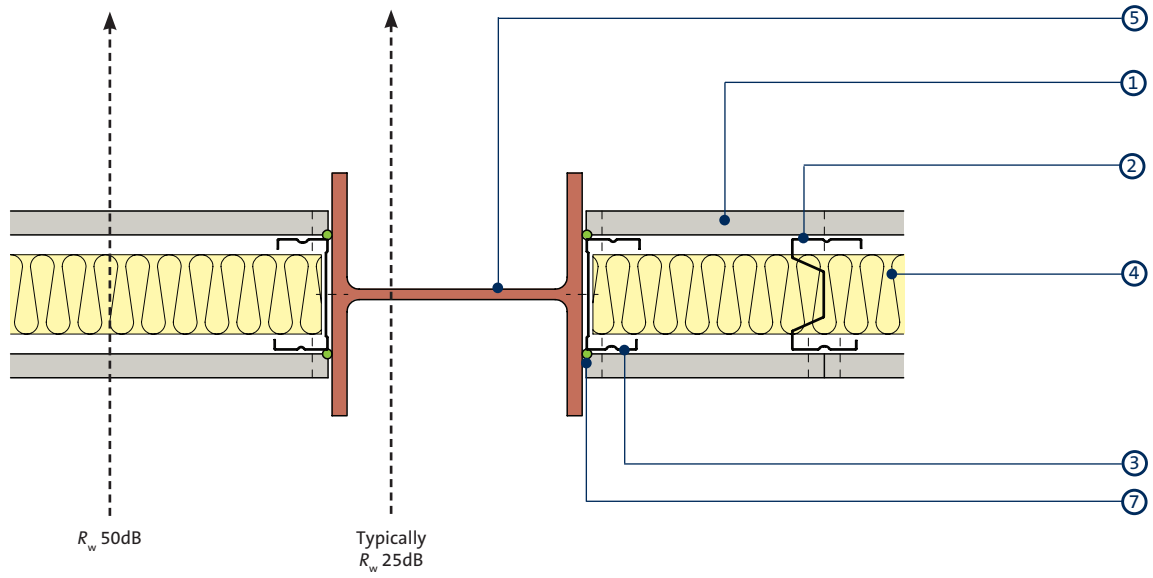

14

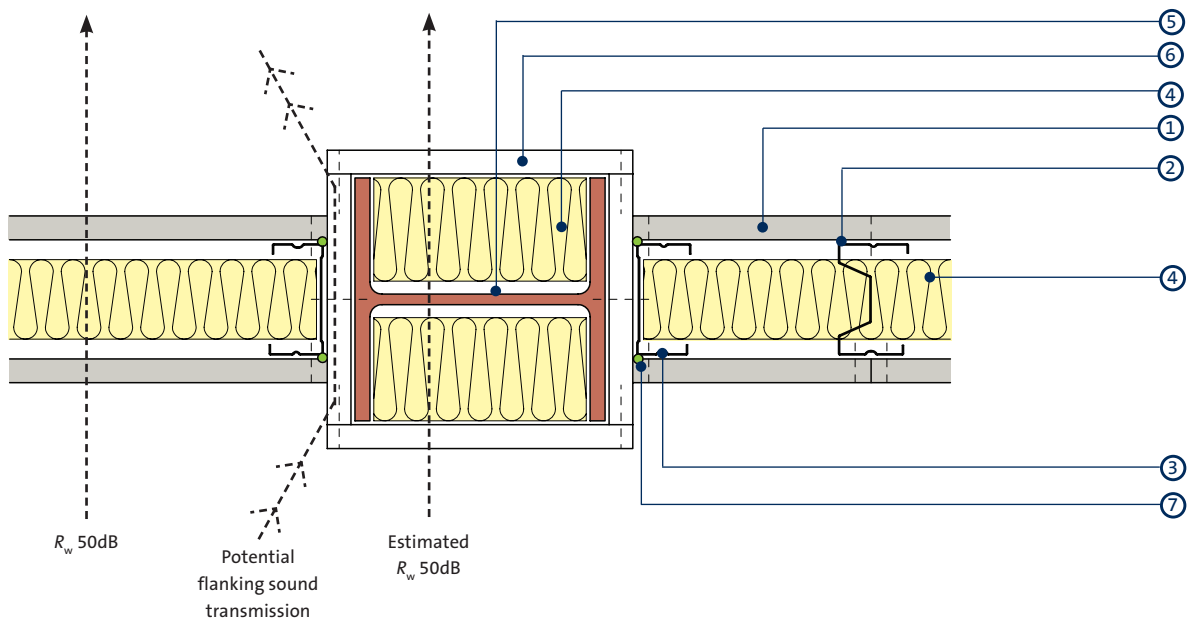

Encased steel column

- 1 Gyproc DuraLine
- 2 Gypframe AcouStud
- 3 Gypframe 'C' Stud
- 4 Isover insulation

- 5 Structural steel
- 6 Glasroc F FIRECASE
- 7 Gyproc Sealant

## FireCase construction details (continued)

15

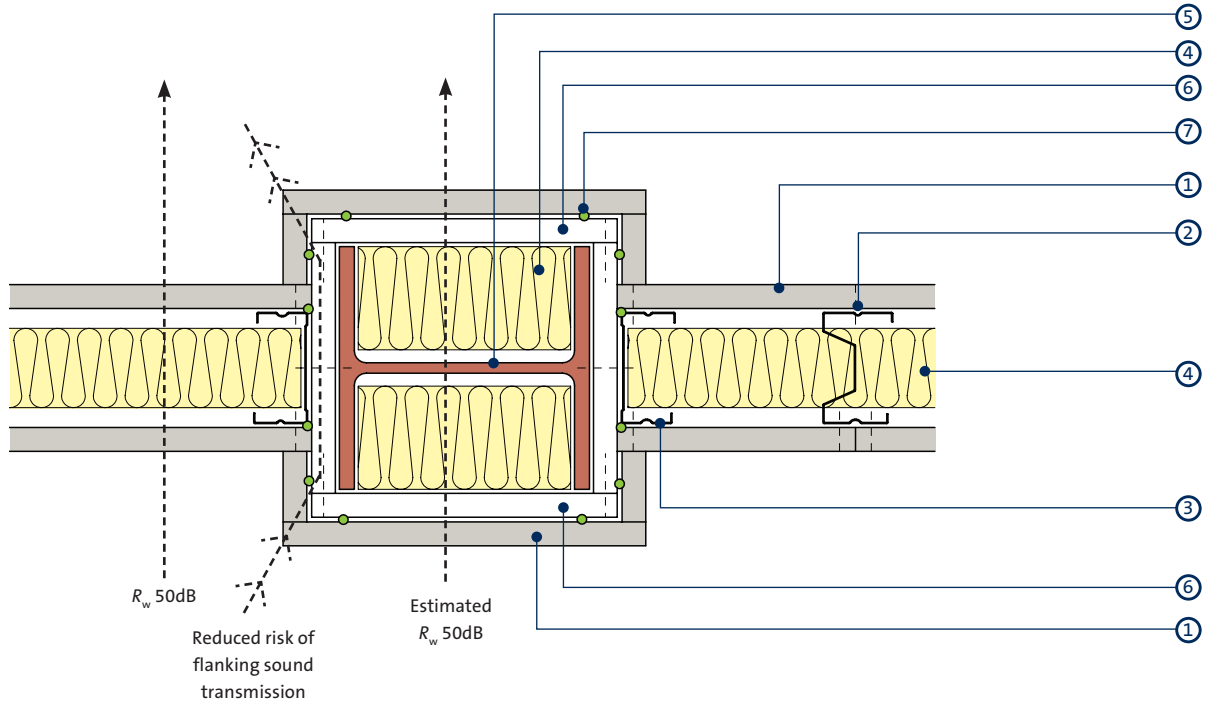

Encased steel column with additional plasterboard lining

16

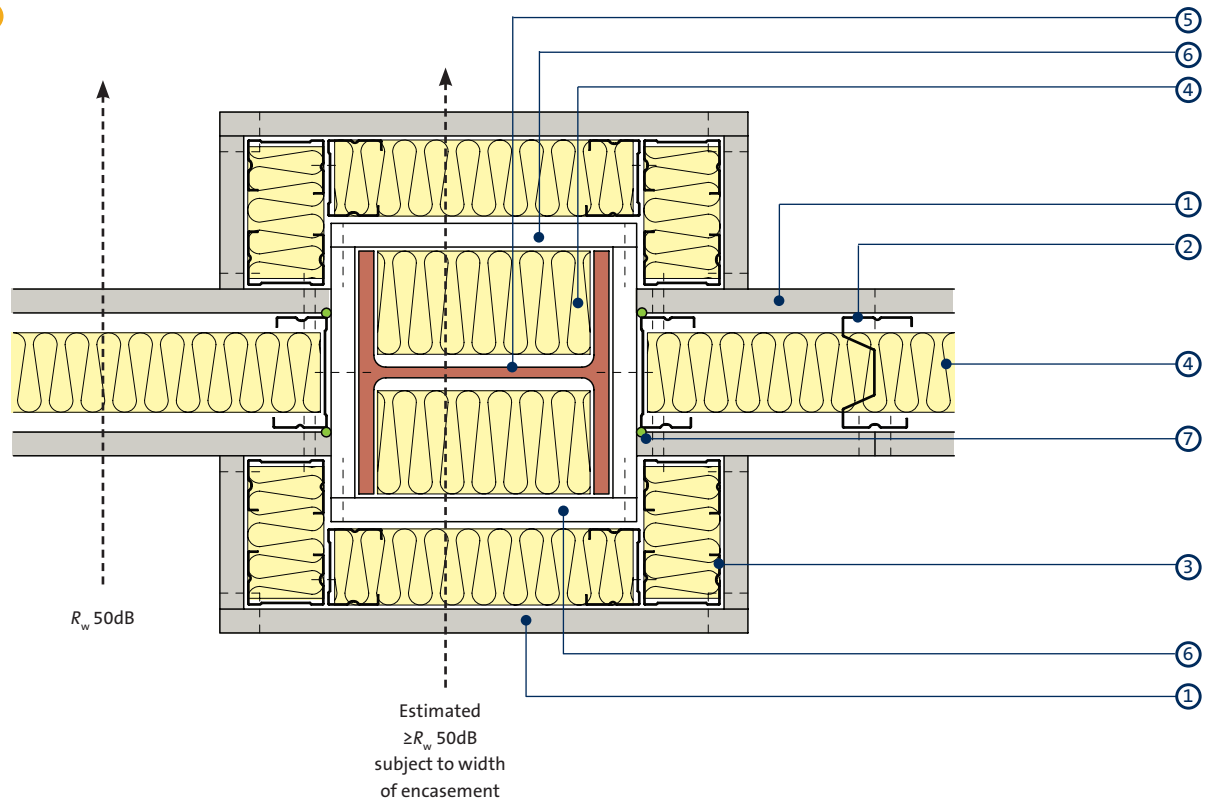

Encased steel column with additional framing, insulation and plasterboard lining

- 1 Gyproc DuraLine
- 2 Gypframe AcouStud
- 3 Gypframe 'C' Stud
- 4 Isover insulation

- 5 Structural steel
- 6 Glasroc F FIRECASE
- 7 Gyproc Sealant

*This page left intentionally blank*

# FireCase system components

## Gypframe metal components



### Gypframe FEA1 Steel Angle

Steel angle providing framing stability and board support.

## Board products



### Glasroc F FIRECASE

Non-combustible glass-reinforced gypsum board giving up to 120 minutes fire protection.

## Fixing products



### Glasroc F FIRECASE Screws

Corrosion resistant self-tapping steel screws with unique head design that countersinks itself into Glasroc F FIRECASE board to board and board to metal framing.

## Plasterboard accessories



### Gyproc Jointing Materials

Jointing compounds, ready mixes and adhesives for reinforcement and finishing of board joints.



### Gyproc Sealant

Used to seal paths for optimal sound insulation.

## Finishing products



### Gyproc Skimcoat

To provide a plaster skim finish on most common backgrounds including undercoat plasters and plasterboard.



### Gyproc Carlite Finish

To provide a plaster skim finish on most common backgrounds including undercoat plasters and plasterboard.



### Gyproc Carlite Ultra Finish

Offers all the benefits of Gyproc Skimcoat and Gyproc Carlite Finish with a reduced set time of 90-120mins, making it ideal for smaller jobs.



### Gyproc Drywall Primer

Used to prepare for painting.  
Tub contents 10 litre.



### Plaster accessories

Designed for the reinforcement and finishing of board joints before plaster skimming.

## FireCase installation overview

This is intended to be a basic description of how the system is built. For detailed installation guidance refer to the Gyproc Installation Guide.



For four-sided protection to steel columns, Glasroc F FIRECASE boards are positioned and fixed board to board using Glasroc F FIRECASE Screws.



For two or three-sided protection to steel beams or columns, Gypframe FEA1 Steel Angles are located to both sides of the wall / soffit flange and secured using appropriate fixings.



Glasroc F FIRECASE boards are cut to width and fixed to the Gypframe FEA1 Steel Angles with Glasroc F FIRECASE Screws.



Where Glasroc F FIRECASE boards abut they can be fixed together with either Glasroc F FIRECASE Screws.



Additional layers of Glasroc F FIRECASE are fixed as before, with staggered joints. For single layer steel beam encasements, additional strips of Glasroc F FIRECASE are installed behind the ends of the fascia board-ends so as to seal the joints.



### Additional information

For full installation details, refer to the **Gyproc Installation Guide**, available to download from [gyproc.ie](http://gyproc.ie)