

DriLyner Wall Linings



Drywall masonry lining systems



DriLyner Wall Linings

Gyproc **DriLyner** systems provide high quality internal linings. They cater for a variety of masonry wall constructions. Linings are bonded using a wide range of adhesive options depending on substrate type. This range of systems provide solutions for all types of buildings both new-build and refurbishment.

Use the table below to select the most appropriate solution for your project requirements.

| System cavity width (mm) | Performance | | | Method of fixing to wall | System | Page |
|--------------------------|---|---|--|--|-------------|----------------|
| |  fire |  Acoustic |  Thermal | | | |
| 10 - 25 | - | - | ✓ | Gyproc Plasterboard Compound | DriLyner | C07. S03. P470 |
| 20 - 25 | - | - | ✓ ¹ | Gypframe MF10 Channels fixed using Gyproc Plasterboard Compound dabs | DriLyner MF | C07. S03. P471 |

¹ Performances not included within this section. Contact the Gyproc Technical Department.

DriLyner range

DriLyner

DriLyner lining system provides a straightforward solution for fixing Gyproc plasterboards directly to masonry backgrounds using gypsum adhesive dabs.

DriLyner is suitable for fixing a wide range of plasterboards to non-plastered masonry substrates.

Key benefits

- Minimal loss in room space due to a typical 15mm drylining cavity plus the thickness of the Gyproc plasterboard and any finish applied
- Allows minor surface irregularities to be taken out within the drylining cavity formed by the gypsum adhesive dabs
- Services can be incorporated with a reduced level of chasing



DriLyner range (continued)

DriLyner MF

DriLyner MF lining system provides a solution for fixing Gyproc plasterboard, including Gyproc WallBoard DUPLEX incorporating a vapour control layer directly to masonry backgrounds using gypsum adhesive dabs and Gypframe channels. High levels of energy efficiency can be achieved to upgrade the performance of existing walls.

Key benefits

- Services can be incorporated without chasing of the masonry substrate
- Allows minor surface irregularities to be taken out within the drylining cavity formed by the gypsum adhesive
- Minimal thermal bridging due to the use of gypsum adhesive dabs between the Gypframe channel and masonry background
- Provides a thermally responsive environment with a quick heating time as a result of positioning the insulation layer on the warm side of the room



Drilyner Wall Linings performance

Fire protection

Plasterboard is designated a 'material of limited combustibility' within Building Regulations TGD Part B (RoI) and Technical Booklet E (NI).

Sound Insulation

Airtightness is essential for optimum sound insulation. Whilst most junctions will be sealed by standard installation and finishing processes, gaps at the base of the wall and other small air paths can be sealed using Gyproc Sealant.

Thermal properties

Gyproc linings are relatively lightweight and have a low thermal capacity. In conditions of intermittent heating, they will warm up quickly providing comfortable conditions for the occupants, and will help reduce the risk of surface condensation.

Condensation and water vapour resistance

Gyproc WallBoard DUPLEX offers significant resistance to water vapour transmission.

It is important, particularly in new buildings, that external walls are properly dried out before a vapour control layer is provided, otherwise moisture may be trapped, impairing the performance of the construction.

This page left intentionally blank

Planning — key factors

The position of services should be pre-determined and their installation planned into the construction stage.

► Refer to C02. S01. P41 – Service installations.

In general, an allowance of the total board thickness plus 10mm for Drilyner should be made from the high point of the background to the face of the lining. This will determine the lining dimension required at door and window reveals and soffits. Ceilings should be installed prior to the application of Drilyner, ensuring that the boards are cut close to the wall.

Interior partitions abutting the inner leaf of the external wall should also be installed prior to installation of Drilyner lining where fire and acoustic performance are a key consideration. This helps to reduce flanking transmission.

Backgrounds



Important information

Walls must be free from dampness before Drilyner system can be installed.

Drilyner linings should only be installed to backgrounds that are reasonably dry and protected from the weather.

In the Drilyner system linings can be fixed directly to low, medium, and high suction masonry, as well as pre-cast and in-situ normal ballast aggregate concrete, using Gyproc Plasterboard Compound. Concrete backgrounds must be free of shutter-release agents and will need to be brushed down to remove dust, and slightly dampened with a wet brush prior to applying adhesive dabs. Concrete which is exceptionally dense or smooth, or made with limestone, brick or granite aggregates, should be pre-treated with ThistleBond-It, which should be applied in bands to correspond with the adhesive dab centres and in accordance with Gyproc's application instructions.

Variations in moisture content of the background will lead to differences in its suction characteristics. When these are extreme, either with slow drying conditions, or dry, hot conditions, care must be taken. If wet, allow the backgrounds to dry out. In dry, hot conditions, care should be taken to avoid rapid loss of moisture prior to the set of the adhesive.

When a considerable quantity of moisture may be present in the building, due to the condition of the building fabric or to prolonged damp weather, consideration should be given to the use of dehumidifiers or appropriate heating and ventilation to speed up the drying-out process. Installation of the lining before the building is adequately dry can have an adverse effect on both the building and the lining itself.

When installing Drilyner linings to composite wall structures consisting of concrete columns with infills of brick or block, dabs of adhesive should not be located on the columns but only on the brick or block infill areas. This will reduce the likelihood of cracking of the finished lining as a result of differential movement within the background.

Adhesive dabs

Dabs should be applied in a regular pattern in accordance with *BS 8212* and *BS 8000: Part 8* to give a minimum area of contact between board and background of 20%.

Services

The cavity between the linings and the background can be used to incorporate services. This minimises the depth of chasing required in the background. Pipes and conduits should be fixed in position before lining work commences. Gas pipes should be installed in accordance with *BS 6891*, which requires pipes to be fully encased, e.g. using Gyproc Plasterboard Compound. To maintain an airtight construction the perimeter of any penetration through the lining should be sealed as necessary at the time the services are being installed.

The insulating backing of the laminates should not be chased to accommodate services. PVC covered cables must not come into direct contact with polystyrene insulation. Suitable isolation methods such as conduit or capping should be used.

The installation of electrical services should be carried out in accordance with *BS 7671*.

Cavity barriers

Building Regulations may require the provision of vertical cavity barriers to long runs of lining. A suitable cavity barrier can be formed using a continuous vertical line of dabs running down the centre of a board.

DriLyner Wall Linings design (continued)

Thermal performance

Uncontrolled air movement through the drylining cavity can result in excessive heat loss from the building. The benefit of thermal insulation using DriLyner systems are based on a sealed cavity between the lining and the background. This is achieved in practice if the abutting elements and the background are constructed correctly, and junctions are sealed.

When the lining is designed to act as an air barrier to achieve building airtightness, the perimeter of the cavity is to be sealed by applying a continuous fillet / ribbon of Gyproc Plasterboard Compound to the perimeter of the external wall and around any services and openings.

Sound insulation

Gyproc Airtite Quiet in conjunction with a mechanically fixed lining system, e.g. Gyplyner, is designed to improve the acoustic performance of masonry party walls by minimising acoustic leakage through cracks, unfilled joints or block porosity. When applying Gyproc Airtite Quiet it is recommended that a 6mm coat is applied across the entire surface area of the separating wall to cover all cracks and voids. The product should not be trowelled smooth.

Alternatively, Isover Acoustic insulation can be used in conjunction with DriLyner and appropriate Gyproc board to give improved acoustic performance.

Fixtures

Lightweight fixtures can be made directly to the lining. For other fixtures, the fixing device used should be long enough to bridge the drylining cavity and give adequate penetration into the solid wall.

▶ Refer to C02. S01. P41 – Service installations.

Tiling

Tiling should only commence seven days after installation.

For further details on tiling guidance:

▶ Refer to C08. S04. P498 – Finishes, Tiling.

Board finishing

▶ Refer to C08. S01. P483 – Finishes.

Drilyner construction details

1

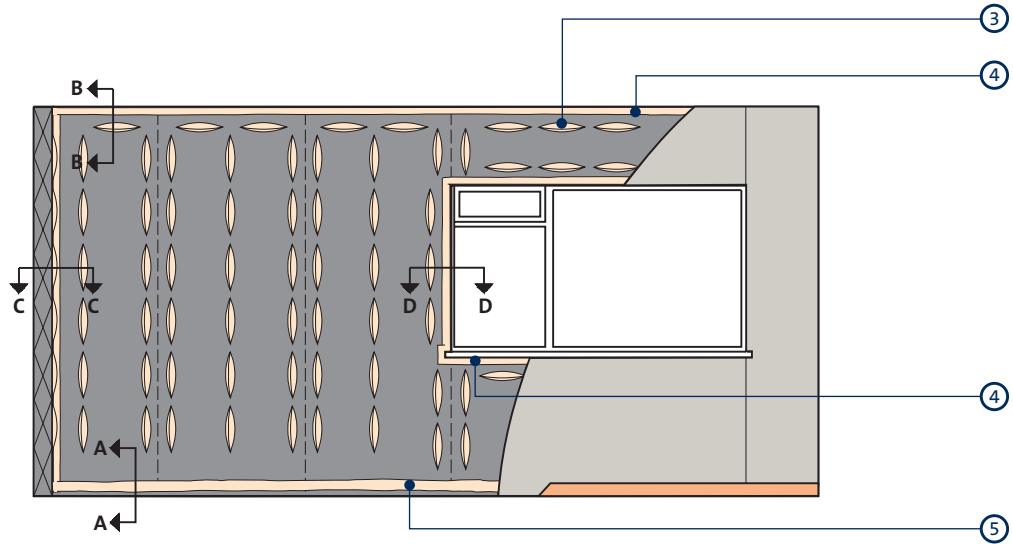

Wall elevation — Gyproc WallBoard 9.5mm and 12.5mm thick, 900mm wide

2

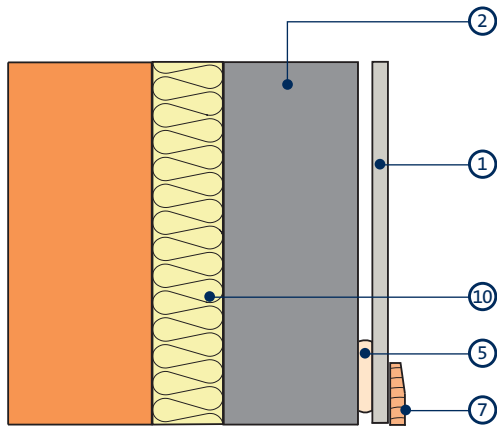

Section A - A

3

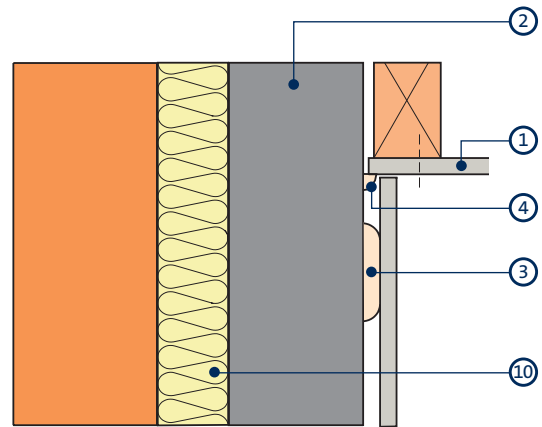

Section B - B

4

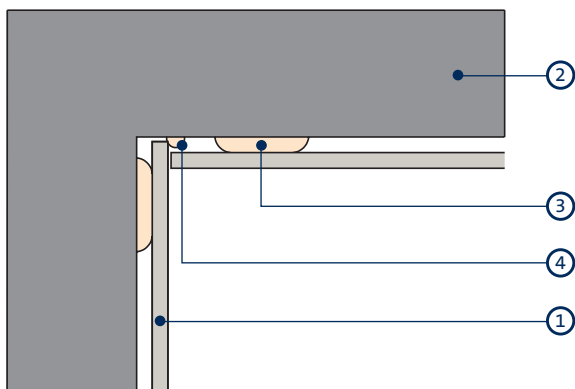

Section C - C

5

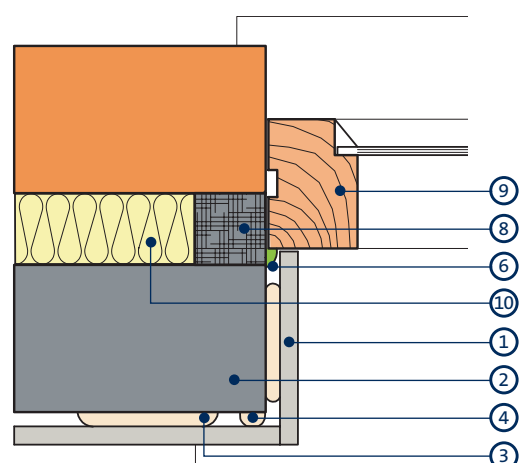

Section D - D

- 1 Gyproc plasterboard
- 2 Masonry wall
- 3 Gyproc Plasterboard Compound dab
- 4 Gyproc Plasterboard Compound fillet
- 5 Gyproc Plasterboard Compound continuous ribbon

- 6 Gyproc Sealant (where required)
- 7 Skirting
- 8 Proprietary cavity closer
- 9 Window unit
- 10 Isover acoustic insulation

Drilyner construction details (continued)

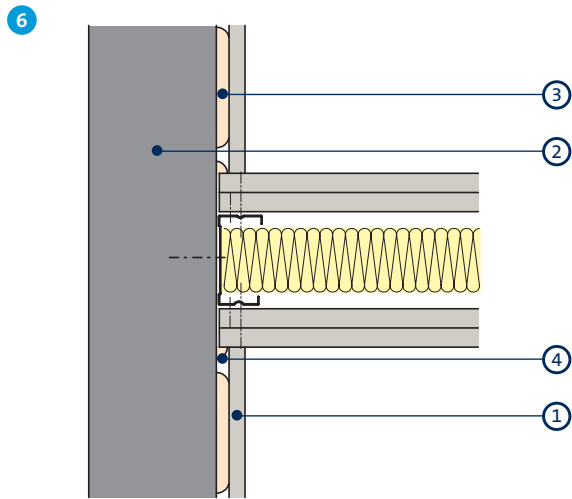

Junction with GypWall

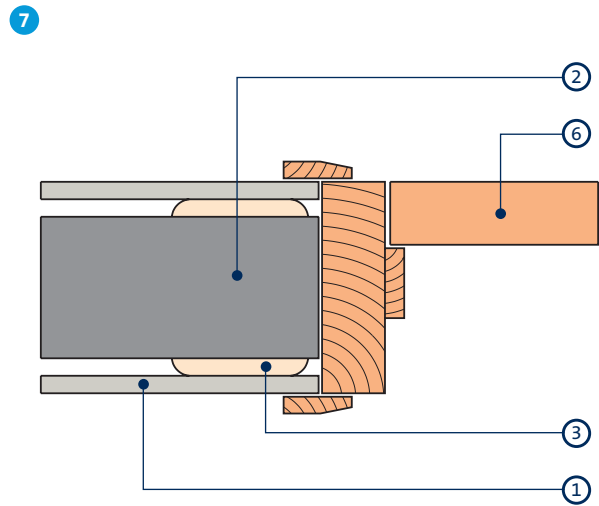

Door frame

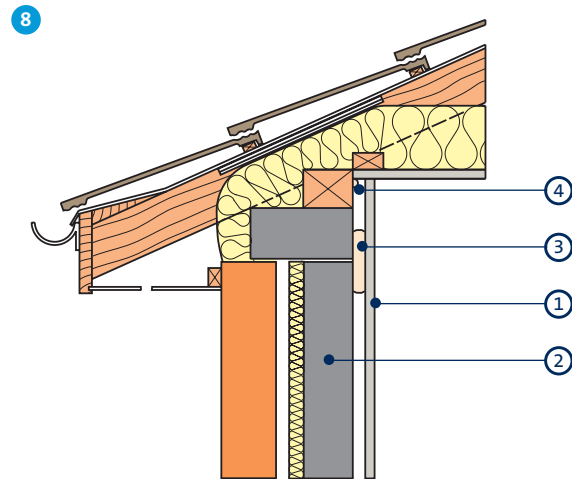

Ceiling to roof junction

- 1 Gyproc plasterboard
- 2 Masonry wall
- 3 Gyproc Plasterboard Compound dab
- 4 Gyproc Plasterboard Compound fillet
- 5 Gyproc Sealant (where required)
- 6 Door assembly

DriLyner MF construction details

9

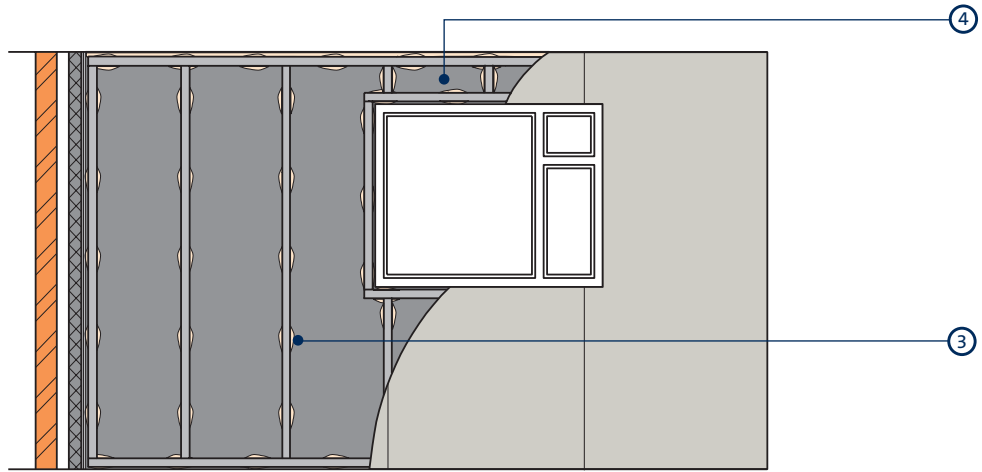

Wall elevation - Gyproc WallBoard, 12.5mm thick, 1200mm wide

10

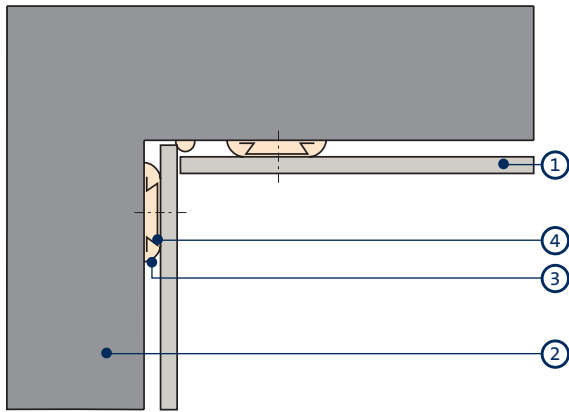

Internal angle

11

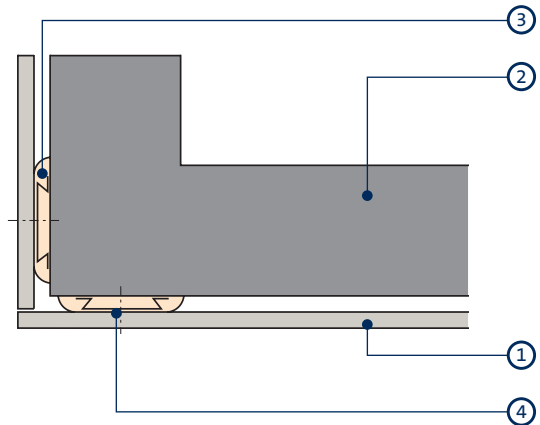

External angle

12

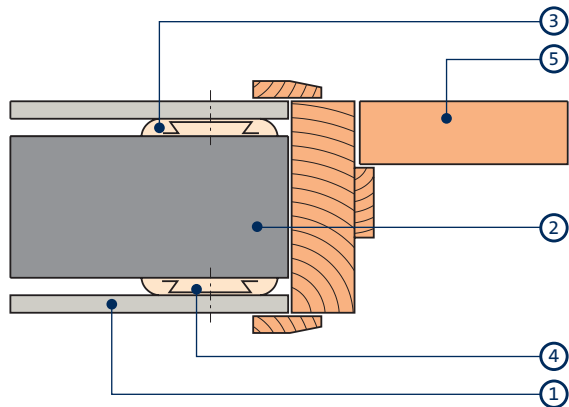

Door frame

1 Gyproc plasterboard

2 Masonry wall

3 Gyproc Plasterboard Compound dab

4 Gyframe MF10 Channel (fixings into channel omitted for clarity)

5 Door assembly

6 Gyproc Sealant

13

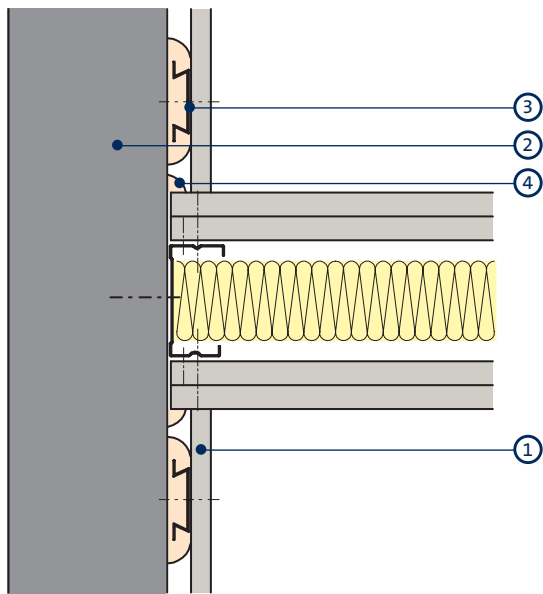

Junction with GypWall

- 1 Gyproc plasterboard
- 2 Masonry wall
- 3 Gypframe MF10 Channel (fixings into channel omitted for clarity)
- 4 Gyproc Plasterboard Compound fillet

DriLyner Wall Linings system components

Gypframe metal components



Gypframe MF10 Channel

Vertical support to receive fixing of board.

Board products



Gyproc WallBoard

Standard gypsum plasterboard.



Gyproc WallBoard DUPLEX

Standard gypsum plasterboard, backed with a vapour control layer.



Gyproc Moisture Resistant

Gypsum plasterboard with moisture resistant additives in the core and special green lining paper for easy recognition.



Gyproc DuraLine¹

Gypsum plasterboard with fire resistant additives and a high density core for enhanced sound insulation and impact resistance performance.

¹ Also available in Moisture Resistant (MR) version. MR boards are specified in intermittent wet use areas.

Fixing products



Gyproc Drywall Screws

Secondary mechanical fixing for Gyproc laminate in the DriLyner MF systems on masonry walls.

Plasterboard accessories



Gyproc Jointing Materials

Jointing compounds, ready mixes and adhesives for reinforcement and finishing of board joints.



Gyproc Plasterboard Compound

For bonding Gyproc boards (dab fixing) and Gypframe MF10 Channels.

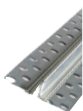

Gyproc Control Joint

To accommodate structural movement of up to 7mm.



Gyproc Sealant

Used for fixing boards in the DriLyner MF system and to seal air paths for optimum sound insulation.



Gyproc Corner Tape

A paper tape bonded to two corrosion resistant steel strips.



Gyproc Paper Joint Tape

A paper tape designed for reinforcement of flat joints or internal angles.



Gyproc Drywall Primer

Used to prepare for painting.
Tub contents 10 litre.

DriLyner Wall Linings system components (continued)

Finishing products



Gyproc Skimcoat

To provide a plaster skim finish on most common backgrounds including undercoat plasters and plasterboard. Can provide enhanced acoustic performance.



Gyproc Carlite Finish

To provide a plaster skim finish on most common backgrounds including undercoat plasters and plasterboard. Can provide enhanced acoustic performance.



Gyproc Carlite Ultra Finish

Offers all the benefits of Gyproc Skimcoat and Gyproc Carlite Finish with a reduced set time of 90-120mins, making it ideal for smaller jobs.



Gyproc Magnetic Plaster

To provide a plaster skim finish that provides an attraction to magnets used to finish a wide range of backgrounds, including undercoat plasters and plasterboard.



Plaster accessories

Designed for the reinforcement and finishing of board joints before plaster skimming.

Insulation products



Isover Acoustic Roll

Glass mineral wool for enhanced thermal performance.

DriLyner Wall Linings installation overview

This is intended to be a basic description of how the system is built.
For detailed installation guidance refer to the [Gyproc Installation Guide](#).

DriLyner



The board edge positions are marked on the wall, and Gyproc Plasterboard Compound is applied to the wall in dabs to support the boards.



A continuous fillet / ribbon of Gyproc Plasterboard Compound is applied to the wall perimeter and around all services and openings as board fixing proceeds. This is particularly important if the lining is designed to act as an air barrier to achieve building airtightness.



Boards are 'tapped' into position.



Lifted tight to the ceiling using a footlifter and supported until the adhesive sets.



Further boards are installed, lightly butted together, to complete the lining.

DriLyner Wall Linings installation overview (continued)

This is intended to be a basic description of how the system is built.
For detailed installation guidance refer to the **Gyproc Installation Guide**.

DriLyner MF



The board edge and centre positions are marked on the wall and dabs of Gyproc Plasterboard Compound are applied progressively to the wall to each vertical line.

Gypframe MF10 Channels are located onto the adhesive dabs and 'tapped' into position. Horizontal channels are similarly located at the head and base.



At angles and reveals, Gypframe MF10 Channels are installed close to the corner to provide support. Door and window openings are framed with Gypframe MF10 Channels. At window openings, the channel at the head forms a ground for fixing curtain track. Where a partition abuts, an additional Gypframe MF10 Channel is installed to provide a fixing ground. Board fixing can proceed once the adhesive has fully set.



A continuous fillet / ribbon of Gyproc Plasterboard Compound is applied to the wall perimeter and around all services and openings as board fixing proceeds. This is particularly important if the lining is designed to act as an air barrier to achieve building airtightness. Boards are screw-fixed to all Gypframe MF10 Channel supports. Screw lengths should be selected to avoid contact with the masonry background.



Additional information

For full installation details, refer to the **Gyproc Installation Book**, available to download from gyproc.ie