

# Gypliner iwl

Independent wall lining system



## Gyplyner iwl

**Gyplyner iwl** independent wall lining is a lightweight, non-loadbearing system, which is built independently of the external wall construction. **Gyplyner iwl** is particularly suitable for buildings where fixing into the background is difficult or not possible. The lining provides fire resistance and acoustic upgrades to structural steel sections clad with lightweight metal sheeting, and can also be used within new or existing masonry walls to increase sound insulation and meet stringent thermal performance requirements.

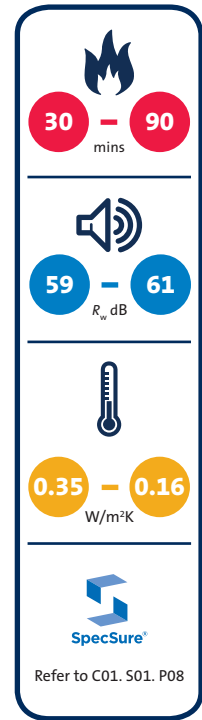

### Key benefits

- Totally independent from wall with fixings to floor and soffit only, particularly suitable for basements with waterproof tanking
- Any surface irregularities within the external wall construction are completely removed through the totally independent framework
- Services are easily incorporated within the framework with no limitation to the cavity size that can be created
- Minimal thermal bridging due to the use of a totally independent framework
- Provides a high-performance option to achieve enhanced acoustic performance and fire protection to steel, in one lining solution

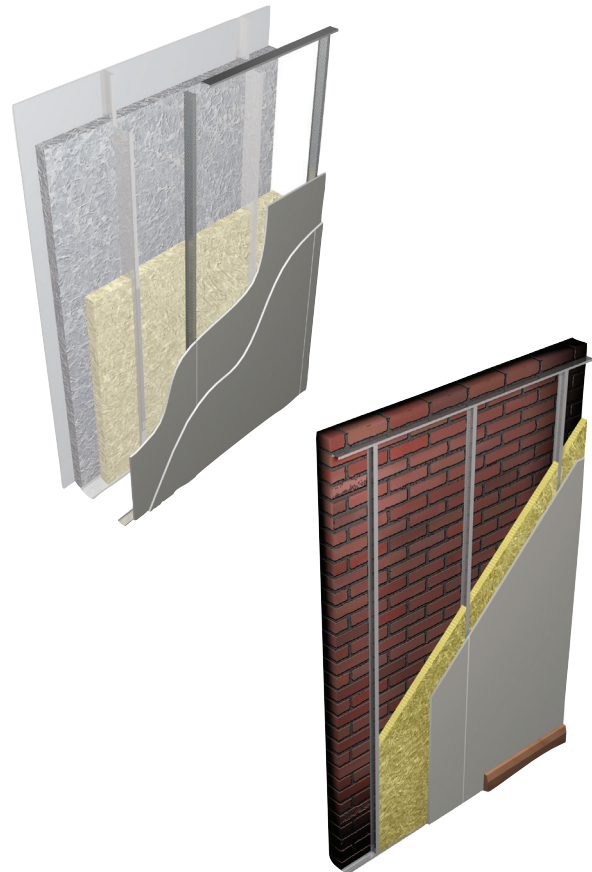

### You may also be interested in...

#### ShaftWall

If you require fire resistance greater than 90 minutes and/or fire resistance in both directions.

► Refer to C05. S02. P291 – **ShaftWall**.



**Table 1a - GypLyner iwl maximum heights<sup>1</sup> for Gypframe 'I' Studs at 600mm centres**

Stud type	12.5mm boards maximum heights		15mm boards maximum heights	
	single mm	double mm	single mm	double mm
Gypframe 48 I 50	2400	2700	2400	2800
Gypframe 60 I 50	2400	3000	2700	3300
Gypframe 60 I 70	3000	3600	3300	3900
Gypframe 70 I 70	3600	4200	3900	4300
Gypframe 92 I 90	5100	5700	5400	5800
Gypframe 146 I 80	6900	7200	7200	7500

**Table 1b - GypLyner iwl maximum heights<sup>1</sup> for Gypframe 'I' Studs at 300mm centres**

Stud type	12.5mm boards maximum heights		15mm boards maximum heights	
	single mm	double mm	single mm	double mm
Gypframe 48 I 50	3000	3400	3000	3600
Gypframe 60 I 50	3000	3800	3400	4300
Gypframe 60 I 70	3800	4500	4200	4900
Gypframe 70 I 70	4500	5200	4900	5500
Gypframe 92 I 90	6400	7100	6800	7200
Gypframe 146 I 80	8700	9000	9100	9500



**Table 1c - GypLyner iwl maximum heights<sup>2</sup> for Gypframe 'I' Studs at 600mm centres**

Stud type	12.5mm boards maximum heights		15mm boards maximum heights	
	single mm	double mm	single mm	double mm
Gypframe 48 I 50	2400	2700	2400	2800
Gypframe 60 I 50	2400	3000	2700	3300
Gypframe 60 I 70	3000	3600	3300	3900
Gypframe 70 I 70	3600	4000	3900	4000

▶ For further assistance in choosing the right solution for your project, try our System Selector; an online tool that enables quick and easy filtering by performance criteria. It provides system specific information downloads including BIM (Revit) objects. Go to [gyproc.ie](http://gyproc.ie)

<sup>1</sup> Based on a limiting deflection of L/240 at 200 Pa.

<sup>2</sup> The maximum heights quoted are limited by the fire state field of application or by limiting deflection L/240@200Pa, whichever is the more onerous

**NB** For heights below 4200mm the appropriate Gypframe Folded Edge Standard Floor and Ceiling Channel (FEC) can be used. For heights between 4200mm and 8000mm, Gypframe Deep Flange Floor and Ceiling Channel (EDC) should be used (subject to deflection criteria). For heights above 8000mm, Gypframe Extra Deep Flange Floor and Ceiling Channel (EDC) should be used (subject to deflection criteria).

**NB** The fire resistances apply to external walls, whose construction incorporates structural steel sections with a profiles steel cladding, when the inside of the wall is exposed to fire.



**Table 2 - Solutions to satisfy the requirements of BS EN 1364-1: 1999 and BS 476: Part 22: 1987**

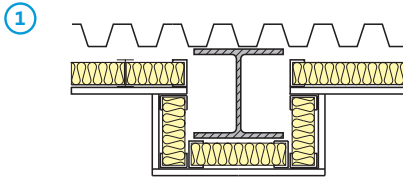

Board linings to one side of Gypframe 'T' Stud framework and 50mm Isover Steel Frame Infill Batts, forming an independent lining to structural steel columns, in association with external steel cladding (0.6mm). Linings as in table.

Detail	Board type <sup>2</sup>	Lining thickness mm	Duty rating	System reference
<b>Fire resistance - 30 minutes integrity<sup>4</sup>: 30 insulation<sup>3,4</sup> EN BS</b>				
1	Gyproc WallBoard	2 x 12.5	Severe	B216003
1	Gyproc SoundBloc	2 x 12.5	Severe	B216003
1	Gyproc WallBoard	2 x 15	Severe	B216004
1	Gyproc SoundBloc	2 x 15	Severe	B216004
<b>Fire resistance - 60 minutes integrity<sup>4</sup>: 30 insulation<sup>3,4</sup> EN BS</b>				
1	Gyproc FireLine	1 x 12.5	Medium	B216025
1	Gyproc FireLine	1 x 15	Heavy	B216026
<b>Fire resistance - 90 minutes integrity<sup>4</sup>: 30 insulation<sup>3,4</sup> EN BS</b>				
1	Gyproc FireLine	2 x 12.5	Severe	B216027
1	Gyproc FireLine	2 x 15	Severe	B216028

▶ For further assistance in choosing the right solution for your project, try our System Selector; an online tool that enables quick and easy filtering by performance criteria. It provides system specific information downloads including BIM (Revit) objects. Go to [gyproc.ie](http://gyproc.ie)

<sup>1</sup> The fire resistances apply to external walls, whose construction incorporates structural steel sections with a profiled steel cladding, when the inside of the wall is exposed to fire.

<sup>2</sup> For improved durability and impact resistance, the outer layer of board can be replaced with a layer of Gyproc DuraLine.

<sup>3</sup> Where the external wall is more than 1m from the boundary, Building Regulations allow relaxation of the provision for insulation to 15 minutes in certain circumstances.

<sup>4</sup> The figures quoted relate to the complete wall structure including the external cladding. The lining also offers fire protection to steel columns from the lining side, subject to A/V (Hp/A) factor. Refer to table 3.

**(NB)** The fire resistance and sound insulation performances are for imperforate partitions, walls and ceilings incorporating boards with all joints taped and filled, or skimmed according to Gyproc's recommendations. The quoted performance (from the underside to the ceiling plenum only) are achieved only if Gyproc and Isover components are used throughout, and the Company's fixing recommendations are strictly observed. Any variation in the specification should be checked with Gyproc.

For details of when to specify fire resistance using EN / BS  
 ▶ Refer to C02. S01. P18



Table 3 - Solutions to satisfy the requirements of DD ENV 13381-2: 2002 and BS 476: Part 21: 1987

Board type	Lining thickness mm	Fire protection mins	Section factor <sup>1</sup> A/V (Hp/A)m <sup>-1</sup>
Gyproc FireLine	1 x 12.5	30	Up to 300
Gyproc DuraLine	1 x 15	30	Up to 300
Gyproc WallBoard or Gyproc SoundBloc	2 x 12.5	30	Up to 300
Gyproc FireLine	1 x 12.5	60	Up to 165 (BS only)
Gyproc FireLine	2 x 12.5	60	Up to 300
Gyproc SoundBloc	2 x 15	60	Up to 300
Gyproc FireLine	2 x 12.5	90	Up to 200 (BS only)
Gyproc FireLine or Gyproc DuraLine	2 x 15	90	Up to 300

▶ For further assistance in choosing the right solution for your project, try our System Selector; an online tool that enables quick and easy filtering by performance criteria. It provides system specific information downloads including BIM (Revit) objects. Go to [gyproc.ie](http://gyproc.ie)

<sup>1</sup> Based on four-sided exposure. Protection is afforded to universal column sections as described in BS 4: Part 1. Based on critical temperature 550°C (information on other critical temperatures is available). A 10mm air gap is required between the back of the board and the face of the structural steel.

**NB** The fire resistance and sound insulation performances are for imperforate partitions, walls and ceilings incorporating boards with all joints taped and filled, or skimmed according to Gyproc's recommendations. The quoted performance (from the underside to the ceiling plenum only) are achieved only if Gyproc and Isover components are used throughout, and the Company's fixing recommendations are strictly observed. Any variation in the specification should be checked with Gyproc.



### You may also be interested in...

If you require steel sections to be encased individually the following options are available:

**Gyplyner ENCASE**

For protection to structural steel for up to 180 minutes.

▶ Refer to C03. S03. P91 – Gyplyner ENCASE

**FireCase**

For frameless protection to structural steel for up to 120 minutes.

▶ Refer to C03. S02. P71 – FireCase

①

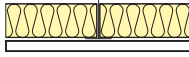
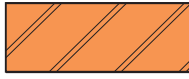

Solid brick wall (103mm) of density 1700kg/m<sup>3</sup> with single or double layer board to one side of Gyprock 'I' Stud framework and 50mm Isover Steel Frame Infill Batts forming an independent lining. Linings as in table.

Detail	Board type	Lining thickness mm	Sound insulation <sup>2</sup> $R_w (R_w + C_{tr})$	Duty rating	Approx. weight kg/m <sup>2</sup>	System reference
①	Gyproc WallBoard	1 x 12.5	59 (51)	Medium	11	B216001
①	Gyproc WallBoard	1 x 15	59 (51)	Medium	13	B216002
①	Gyproc WallBoard	2 x 12.5	61 (54)	Severe	20	B216031
①	Gyproc WallBoard	2 x 15	61 (54)	Severe	23	B216033

► For further assistance in choosing the right solution for your project, try our System Selector; an online tool that enables quick and easy filtering by performance criteria. It provides system specific information downloads including BIM (Revit) objects. Go to [gyproc.ie](http://gyproc.ie)

<sup>1</sup> The fire resistance quoted is that provided by the masonry wall without contribution from the lining.

<sup>2</sup> Existing solid masonry wall of density 1700kg/m<sup>3</sup> achieving  $R_w$  45dB prior to lining, and with a 10mm cavity between masonry and back of metal framing.

**NB** The sound insulation performances are for imperforate partitions, walls and ceilings incorporating boards with all joints taped and filled, or skimmed according to Gyproc's recommendations. The quoted performance (from the underside to the ceiling plenum only) are achieved only if Gyproc and Isover components are used throughout, and the Company's fixing recommendations are strictly observed. Any variation in the specification should be checked with Gyproc Technical Department.

## Building design

Whilst Gyplyner iwL lining systems are non-loadbearing, they are able to provide resistance to levels of horizontal non-uniformly distributed loads.

▶ Refer to C02. S01. P37 – Robustness.

## Planning - key factors

Gyplyner iwL comprises of Gyprframe 'I' Studs installed at 600mm centres within Gyprframe Floor & Ceiling Channels to receive board to one side. The position of services should be pre-determined and their installation planned into the frame erection stage. It is important that all parts of the lining system, including the thermal insulation, should remain independent of the external walling. The lining is erected with the external walling in place and the windows and doors fixed.



### Important information

Walls must be free from damp before the Gyplyner iwL system can be installed.

## Extended heights

Where the wall height exceeds the available length of the Gyprframe 'I' Stud, sections of stud can be spliced together to the required length using 600mm lengths of the appropriate floor and ceiling channel, fixed with four Gyproc Wafer Head Drywall Screws in each flange to each side.

▶ Refer to construction detail 2.

Where greater heights than listed in table 1a and 1b are required, it may be possible to brace the lining back to the structure. Note that the system is non-loadbearing and should not be used to provide lateral restraint to masonry or other external wall constructions.

## Junction with a suspended ceiling

Where a Gyplyner iwL system is to be fixed to the framework of a CasoLine mF ceiling, in accordance with Gyproc's installation instructions, it's permissible maximum height is equal to that of where it is fixed direct to a structural soffit of the same height.

In situations where a Gyplyner iwL system passes through a CasoLine mF ceiling, which is to one side of the lining and appropriately fixed to both this lining and perimeter partitions / walls, consideration can be given to the lateral restraint provided by the ceiling when developing the lining specification.

The relevant maximum height is the greater of the floor to CasoLine mF ceiling or ceiling to structural soffit height. Care should be taken during installation of tall linings so as to not adversely affect their performance.

## Acoustic performance

Gyplyner iwL can be used as an independent lining to improve the sound insulation of new or existing masonry walls. Acoustic testing on a basic masonry wall construction achieving  $R_w$  45dB sound insulation gave a 14dB improvement when the wall was lined with Gyplyner iwL. A 16dB improvement was achieved with a double layer lining incorporating Isover insulation. Refer to table 4. Careful detailing is required at junctions with sound insulating partitions in order to maintain acoustic performance.

▶ Refer to construction detail 6.

## Cavity fire barriers

Cavity fire barriers should be included where necessary. If both sides of the cavity are formed by non-combustible or Class 0 materials, barriers are necessary only every 20m. The nature of the barrier and its fixing should not detract from the general performance of the wall.

## Fixing floor and ceiling channels

Gyprframe Floor & Ceiling Channels must be securely fixed with a row of fixings at 600mm maximum centres. For 94mm and 148mm channels, two rows of staggered fixings are required, each row at 600mm centres and each fixing 25mm in from the flange. If the floor is uneven, a 38mm thick timber sole plate equal to the width of the channel should be used.

If the concrete or screeded floor is new, consideration should be given to the installation of a damp-proof membrane between the floor surface and the channel or sole plate.



### Important information

The inclusion of control joints should be considered.

▶ Refer to C02. S01. P39 – Robustness, and construction details 7-8 within this section.

### Deflection heads

The system can accommodate deflection at the head with suitable detailing incorporating Gypframe Deep Flange or Extra Deep Flange Floor & Ceiling Channels.

▶ Refer to C02. S01. P23 and C07. S05. P508 – construction detail 4.

### Damp or rain penetration

In refurbishment projects, where damp or rain penetration may exist, normal corrective measures, such as a new damp course, tanking, or external wall coating, must be taken prior to the installation of the dry internal lining. The cavity between the external wall and the lining system could be drained and ventilated to the outside.

### Thermal performance

Uncontrolled air movement through the drylining cavity can result in excessive heat loss from the building. This can be reduced in practice if the abutting elements and the background are well fitted, and junctions are sealed. The designer should also specify a method of restricting air movement around the perimeter of suspended timber floors, such as the provision of a flexible seal between the floor and walls.

### Condensation and water vapour resistance

Gyproc WallBoard DUPLEX offers additional resistance to water vapour transmission.

The use of Gyproc WallBoard DUPLEX with integral vapour control significantly reduces the risk of interstitial condensation.

It is important, particularly in new buildings, that external walls are properly dried out before a vapour control layer is provided, otherwise moisture may be trapped, impairing the performance of the construction.

### Insulation

Isover Steel Frame Infill Batts are inserted to a friction-fit within the stud cavity. The slabs are self-supporting, receiving internal support from the stud flanges, except where 50mm insulation is fitted into Gypframe 92 I 90 or 146 I 80 'I' Studs. In this case, a 150mm x 50mm strip of Isover Steel Frame Infill Batts is inserted to retain the slab. With Gypframe 146 I 80 'I' Stud, two strips of insulation should be inserted to retain the slab.

### Services

The stud cut-outs can be used for services provided that the Isover insulation remains in place. The positioning of stud cut-outs is shown in construction detail 1.

Surface mounted services should be located against the plasterboard lining, and fixed through the lining to the stud framework. Any interruptions in the lining integrity will downgrade its performance. The installation of electrical services should be carried out in accordance with BS 7671.

### Fixtures

Lightweight fixtures can be made directly to the partition linings. Medium weight fixtures can be made to Gypframe 99 FC 50 Fixing Channel. Heavyweight fixtures (to BS 5234), such as wash basins and wall cupboards, can be fixed using plywood secured with Gypframe Service Support Plates.

▶ Refer to C02. S01. P41 – Service installations.

### Board finishing

▶ Refer to C08. S01. P483 – Finishes.

### Tiling

Tiles up to 32kg/m<sup>2</sup> can be applied to the surface of lightweight wall lining systems. For further details on tiling guidance:

▶ Refer to C08. S04. P498 – Tiling.

# Gypliyner iwl construction details

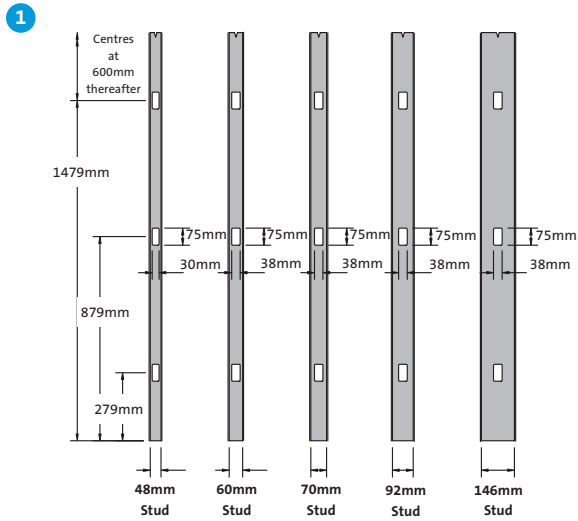

Service cut-outs - Gypframe 'C' Studs and Gypframe 'I' Studs

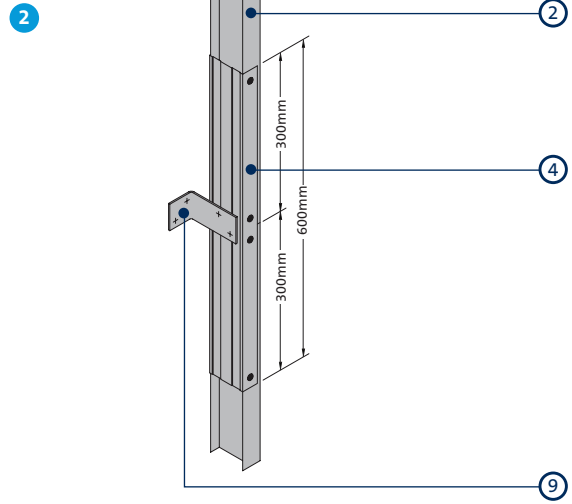

Gypframe 'I' Stud / splicing and bracing

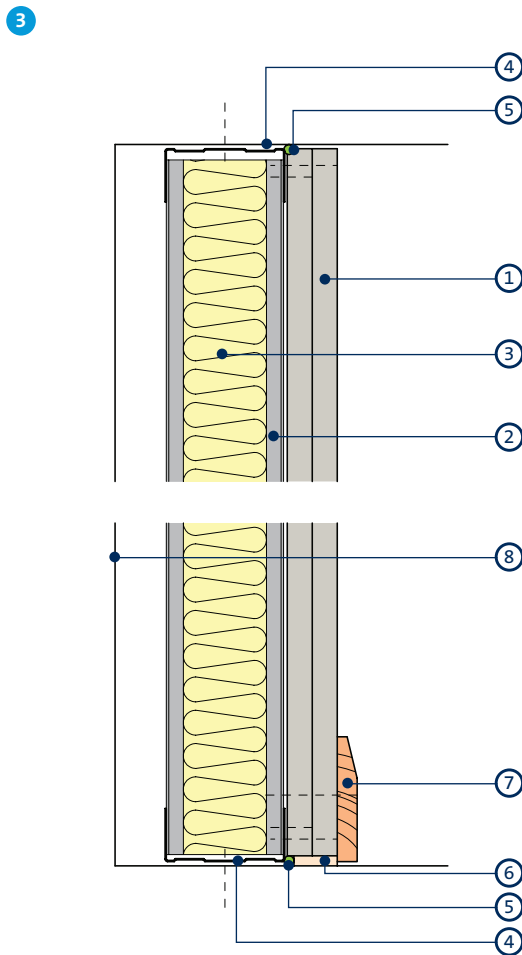

Head and base

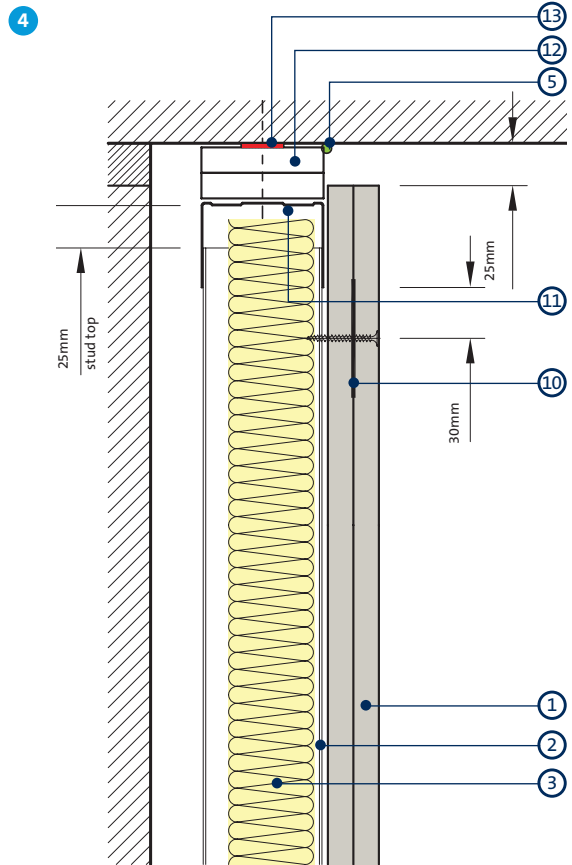

25mm deflection head - BS 476 Part 22: 1987

- 1 Gyproc plasterboard
- 2 Gypframe 'I' Stud
- 3 Isover Acoustic Insulation
- 4 Gypframe Folded Edge Standard Floor & Ceiling Channel
- 5 Gyproc Sealant
- 6 Bulk fill with Gyproc jointing materials (where gap exceeds 5mm)
- 7 Skirting

- 8 Wall structure
- 9 Suitable size angle brace by others
- 10 Gypframe GSF1 Fixing Strap
- 11 Gypframe 72 DC 60 Deep Flange Floor & Ceiling Channel
- 12 Glasroc F FIRECASE
- 13 Gyproc FireStrip

5

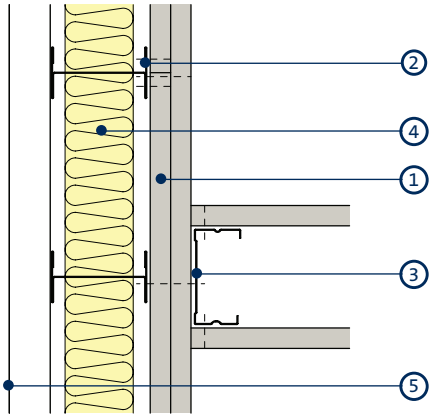

Partition junction

6

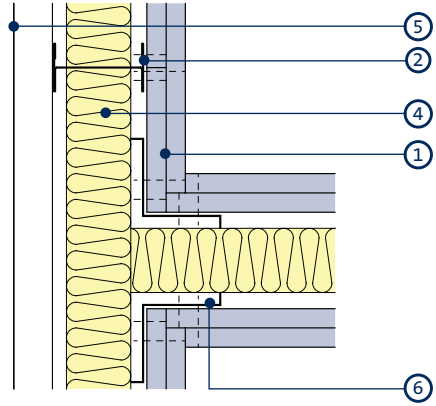

Partition junction to optimise acoustic performance and reduce flanking transmission

7

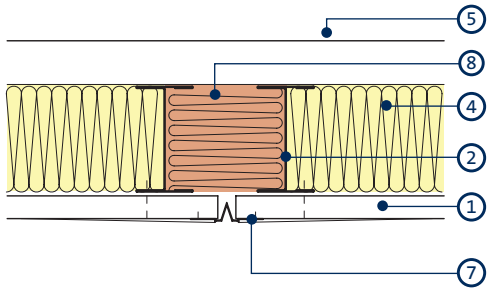

Gyproc control joint - single board

8

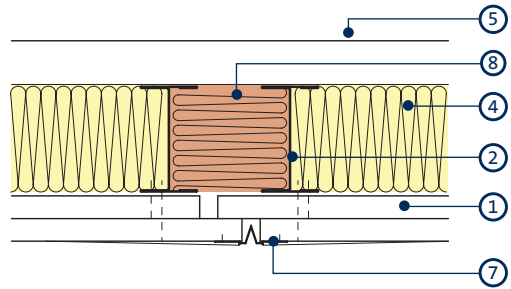

Gyproc control joint - double board

- 1 Gyproc plasterboard
- 2 Gyframe 'I' Stud
- 3 Gyframe 'C' Stud
- 4 Isover Acoustic insulation

- 5 Wall structure
- 6 Gyframe GA5 Internal Fixing Angle
- 7 Gyframe Control Joint
- 8 Stone mineral wool

## Gyplyner iwl construction details (continued)

9

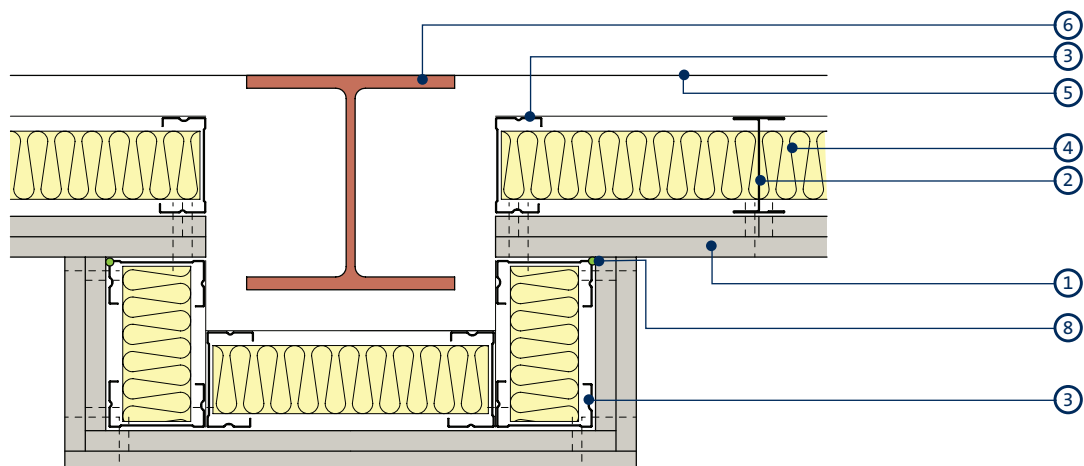

Lining around steel column

- 1 Gyproc plasterboard
- 2 Gypframe 'I' Stud
- 3 Gypframe 'C' Stud
- 4 Isover Acoustic Insulation

- 5 Wall structure
- 6 Steel column
- 7 Concrete column
- 8 Gyproc Sealant

## Gypframe metal components

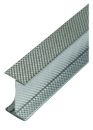

### Gypframe 'I' Studs (48 I 50, 60 I 50, 60 I 70, 70 I 70, 92 I 90, 146 I 80)

Enhanced strength stud that allows for lining height, without increasing lining width. Designed to receive fixing of board to one side only.



### Gypframe 99 FC 50 Fixing Channel

A versatile metal fixing channel used to support medium weight fixtures on walls.

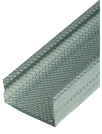

### Gypframe 'C' Studs (48 S 50, 60 S 50, 70 S 50, 92 S 50, 146 S 50)

Vertical stud providing acoustic and structural performances designed to receive fixing of board. Used at openings and abutments.

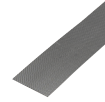

### Gypframe GFS1 Fixing Strap

Used to support horizontal board joints.

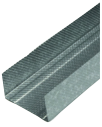

### Gypframe Folded Edge Standard Floor & Ceiling Channels (50 FEC 50, 62 FEC 50, 72 FEC 50, 94 FEC 50, 148 FEC 50)

Standard floor and ceiling channels for retaining the Gypframe studs at floor and ceiling junctions and around openings to heights not exceeding 4200mm.



### Gypframe GFT1 Fixing T

Used to support horizontal board joints. Best suited for single board solutions.

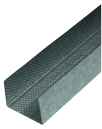

### Gypframe Deep Flange Floor & Ceiling Channels (50 DC 60, 62 DC 60, 72 DC 60, 94 DC 60, 148 DC 60)

Floor and ceiling channels with deep flanges for retaining the Gypframe studs at floor and ceiling junctions for partitions 4200mm to 8000mm high. Also used around openings and in deflection heads (maximum 30mm deflection).

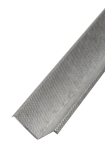

### Gypframe GA5 Internal Fixing Angle

Steel angle providing framing stability and board support.

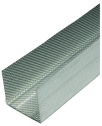

### Gypframe Extra Deep Flange Floor & Ceiling Channels (50 EDC 70, 72 EDC 80, 94 EDC 70, 148 EDC 80)

Floor and ceiling channels with extra deep flanges for retaining the Gypframe studs at floor and ceiling junctions for partitions over 8000mm high. Also used around openings and in deflection heads (maximum 50mm deflection).

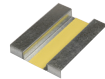

### Gypframe Service Support Plate

For installation of 18mm plywood within a partition cavity to support medium to heavyweight fixtures.

## Gyplyner iwL system components (continued)

### Board products



#### Gyproc WallBoard<sup>2</sup>

Standard gypsum plasterboard.



#### Glasroc H TILEBACKER

Non-combustible glass-reinforced gypsum board with a water resistant pre-primed acrylic coating to receive tiling.



#### Gyproc FireLine<sup>1,2</sup>

Gypsum plasterboard with fire resistant additives.



#### Glasroc F FIRECASE

Non-combustible glass-reinforced gypsum board. Used to form deflection head.



#### Gyproc SoundBloc<sup>1</sup>

Gypsum plasterboard with a high density core for enhanced sound insulation performance.



#### Gyproc Duraline<sup>1</sup>

Gypsum plasterboard with fire resistant additives and a high density core for enhanced sound insulation and impact resistance performance.

<sup>1</sup> Also available in Moisture Resistant (MR) version. MR boards are specified in intermittent wet use areas.

<sup>2</sup> Also available in DUPLEX grades where vapour control is required.

### Fixing products



#### Gyproc Drywall Screws

Corrosion resistant self-tapping steel screws for fixing board-to-timber and board-to-metal framing less than 0.8mm thick. ("I" studs less than 0.6mm thick)



#### Gyproc Collated Drywall Screws

Corrosion resistant self-tapping steel screws for fixing board-to-timber and board-to-metal framing less than 0.8mm thick. ("I" studs less than 0.6mm thick)



#### Gyproc Jack-Point Screws

For fixing boards to Gyproframe metal framing 0.8mm thick or greater ('I' studs 0.6mm thick and greater).



#### Gyproc Wafer Head Drywall Screws

Corrosion resistant self-tapping steel screws for fixing metal to metal framing less than 0.8mm thick ('I' studs less than 0.6mm thick).



#### Gyproc Wafer Head Jack-Point Screws

Corrosion resistant self-tapping steel screws for fixing metal to metal framing 0.8mm thick or greater ('I' studs 0.6mm thick and greater).

## Gypliner IWL system components (continued)

### Plasterboard accessories



#### Gyproc Sealant

Used to seal air paths for optimum sound insulation.



#### Gyproc Control Joint

To accommodate structural movement of up to 7mm.



#### Gyproc Jointing Materials

Jointing compounds, ready mixes and adhesives for reinforcement and finishing of board joints.



#### Gyproc FireStrip

A soft extruded linear intumescent gap sealer to maintain fire resistance located directly to the underside of the soffit when forming a deflection head.



#### Gyproc Drywall Primer

Used to prepare for painting.  
Tub contents 10 litre.



#### Gyproc Paper Joint Tape

A paper tape designed for reinforcement of flat joints or internal angles.

### Finishing products



#### Gyproc Skimcoat

To provide a plaster skim finish on most common backgrounds including undercoat plasters and plasterboard. Can provide enhanced acoustic performance.



#### Gyproc Carlite Finish

To provide a plaster skim finish on most common backgrounds including undercoat plasters and plasterboard. Can provide enhanced acoustic performance.



#### Gyproc Carlite Ultra Finish

Offers all the benefits of Gyproc Skimcoat and Gyproc Carlite Finish with a reduced set time of 90-120mins, making it ideal for smaller jobs.



#### Gyproc Magnetic Plaster

To provide a plaster skim finish that provides an attraction to magnets used to finish a wide range of backgrounds, including undercoat plasters and plasterboard.

### Insulation products



#### Isover Steel Frame Infill Batts

Glass mineral wool for enhanced acoustic and thermal performance.

## Gyplyner iwl installation overview

This is intended to be a basic description of how the system is built.  
For detailed installation guidance refer to the [Gyproc Installation Guide](#).

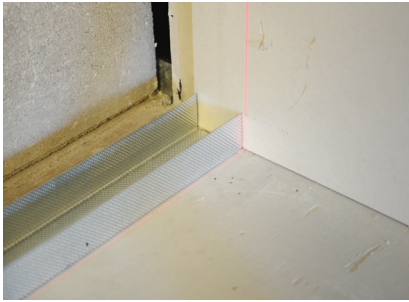

Gypframe Floor & Ceiling Channels are suitably fixed to the floor and soffit. Gypframe 'C' Studs are suitably fixed to openings and abutments.



Gypframe 'I' Studs are friction-fitted vertically at the required centres within the channel sections to form the framework. Additional framing is installed as required to support heavy fixtures.



The perimeter of each frame is then sealed with Gyproc Sealant.



If specified, Isover acoustic insulation is fitted between studs. Electrical and other services are normally installed at the frame erection stage. Horizontal runs are fixed to the background or can be routed through cut-outs in the studs. Gypframe 99 FC 50 Fixing Channel can be installed between studs to support recessed switch boxes / socket outlets.



Boards are screw-fixed to framing members to form the lining. Horizontal board joints should be backed with Gypframe GFS1 Fixing Strap or Gypframe GFT1 Fixing 'T'.



### Additional information

For full installation details, refer to the [Gyproc Installation Guide](#), available to download from [gyproc.ie](http://gyproc.ie)