

Technical performance and principles of system design

Building acoustics

Principles of building acoustics

Building acoustics is the science of controlling noise in buildings, including the minimisation of noise transmission from one space to another, and the control of noise levels and characteristics within a space.

Noise can be defined as sound that is undesirable, but it can be subjective and depends on the reactions of the individual. When a noise is troublesome, it can reduce comfort and efficiency. If a person is subjected to noise for long periods, it can result in physical discomfort or mental distress. Within homes, a noisy neighbour can be one of the main problems experienced in attached housing. It's estimated that up to 300,000 people in Ireland have had their lives disturbed by noisy neighbours.

The best defence against noise is to ensure that proper precautions are taken at the design stage and during construction of the building. The correct acoustic climate must be provided in each space, and noise transmission levels should be compatible with the building's usage. Retrofitted remedial measures taken after occupation can be expensive and inconvenient.

The term 'building acoustics' covers both sound insulation and sound absorption.

Sound insulation

Sound insulation is the term describing the reduction of sound that passes between two spaces separated by a dividing element.

In transmitting between two spaces, the sound energy may pass through the dividing element (direct transmission) and through the surrounding structure (indirect or flanking transmission). When designing for optimum sound insulation, it's important to consider both methods of transmission. The walls or floors, which flank the dividing element, constitute the main paths for flanking transmission, but this can also occur at windows, doorways, heating or ventilation ducts, for example.

The acoustic environment of the room and/or the building, and the ability to reduce or eliminate air paths in the vicinity of the sound reducing element, these include doorsets, glazing, suspended ceiling cavities, ductwork, etc. will have a significant effect on its performance. For these reasons it is unlikely that figures quoted from laboratory test conditions will be achieved in practice. When the background noise is low, consideration may have to be given to a superior standard of sound insulation performance in conjunction with the adjoining flanking conditions.

In any existing sound insulation problem, it is essential to identify the weakest parts of the composite construction.

The Building Regulation requirements regarding the sound insulation of walls and partitions only relate to the transmission of airborne sounds. These include speech, musical instruments, loudspeakers and other sounds that originate in the air. In most cases, floors must also resist the transmission of impact sounds, such as heavy footsteps and the movement of furniture.

Indirect paths (flanking transmission)

Flanking sound is defined as sound from a source room that is not transmitted via the separating building element. It is transmitted indirectly via paths such as windows, external walls and internal corridors. Refer to figure 1.

It is imperative that flanking transmission is considered at the design stage and construction detailing is specified so as to eliminate or at least to minimise any downgrading of the acoustic performance. The sound insulation values quoted in system performance tables are laboratory values and the practicalities of construction will mean that acoustic performances measured in the laboratory will be difficult to achieve on site.

One of the main reasons for this difference is the loss of acoustic performance via flanking transmission paths. Good detailing at the design stage will minimise this effect and optimise the overall levels of acoustic privacy achieved.

If designing for residential units, design advice on flanking details must be followed to maximise the possibility of achieving the specified acoustic performance. It is imperative that the design advice is followed, otherwise site sound insulation values may not meet the minimum standards required by Building Regulations and expensive remedial treatment will be required.

Small openings such as gaps, cracks or holes will conduct airborne sounds and can significantly reduce the sound insulation of a construction. For optimum sound insulation a construction must be airtight. Within masonry construction, most gaps can be sealed at the finishing stage using Gyproc Airtite Quiet, Gyproc plaster or Gyproc jointing compounds. At the base of the partition, gaps will occur, particularly when boards are lifted tight to the ceiling. Small gaps or air paths can be sealed with Gyproc Sealant.

Technical performance and principles of system design

Building acoustics (continued)

1



Common flanking paths

2

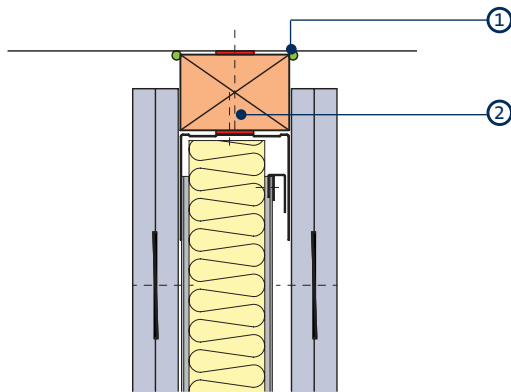

Deflection head A (subject to fire performance)

3

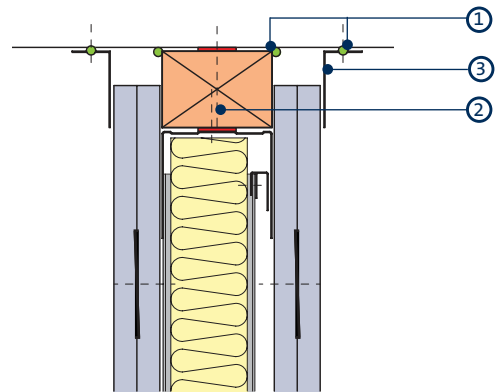

Deflection head B (subject to fire performance)

- 1 Gyproc Sealant for optimum sound insulation
- 2 50mm timber head plate equivalent to channel width forming fire-stop

- 3 Gypframe GA4 Steel Angle to minimise loss of sound insulation performance due to air leakage

Technical performance and principles of system design

Building acoustics (continued)

Acoustic performance of deflection head details

Deflection heads, by definition, must be able to move and, therefore, achieving an airtight seal is very difficult without incorporating sophisticated components and techniques. Air leakage at the partition heads will have a detrimental effect on acoustic performance of any partition.

The approach shown in figure 2 could, for example, result in a loss of around 4dB to 5dB due to air leakage, in addition to any performance lost due to flanking transmission.

Where acoustic performance is a key consideration, steps can be taken to minimise this loss of performance. Figure 3 shows the generally accepted method of achieving this and, provided that care is taken to ensure a tight fit between the cloaking angle and lining board surface, the loss in performance can be reduced.

Other factors, such as flanking transmission through the structural soffit, can significantly affect the overall level of sound insulation. Therefore, other measures may need to be taken.

- A suspended ceiling installed on both sides of the partition may provide a similar cloaking effect to that of steel angles
- **CasoLine MF** incorporating imperforate plasterboard can deliver a similar reduction in air leakage at the partition head. A tight fit between the ceiling perimeter and the surface of the partition lining board is important, although mechanically fixed perimeters are not essential

Ceilings with recessed light fittings may be less effective and if these cannot be sealed in some way, the installation of cloaking angles at the partition head should be considered. A suspended ceiling may also reduce the level of sound flanking transmission via the soffit.

Where perforated ceilings are used, e.g. Gyptone, the angles as shown in figure 3 are recommended. However, if the distance between the ceiling and the deflection head is greater than 200mm, and the ceiling plenum contains Isover insulation (minimum 25mm), the angles may not be required.

Partition to structural steelwork junctions

When designing the layout of rooms requiring separation by sound insulating walls abutting structural steelwork, consideration should be given to the potential loss of sound insulation performance through the steelwork.

Figures 4 to 7 are example details relating to a typical scenario where a partition is specified against a requirement of R_w 50dB. Although these details refer to structural steel column abutments, similar principles apply when abutting structural steel beams. We recommend that these details are checked by an Acoustic Consultant, in particular the performance via the flanking structure.

Sound by-passing a partition via the void above a suspended ceiling

This is a common source of sound transmission, particularly where the ceiling is absorbent to sound. Sound can easily travel through a perforated tile, or lightweight suspended ceiling, and over the top of a partition where it abuts the underside of the suspended ceiling. Where sound insulation is important, partitions should, wherever possible, continue through the ceiling to the structural soffit, and be sealed at the perimeter junctions. Gyproc plasterboard suspended ceilings offer better insulation where partitions must stop at ceiling level to provide a continuous plenum. In this instance, a cavity barrier can be incorporated above the ceiling line.

Figures 8 to 11 show the stages of sound insulation improvement for typical ceiling/high performance partition junctions. The best result is achieved by running the partition through to the structural soffit.

Technical performance and principles of system design

Building acoustics (continued)

4

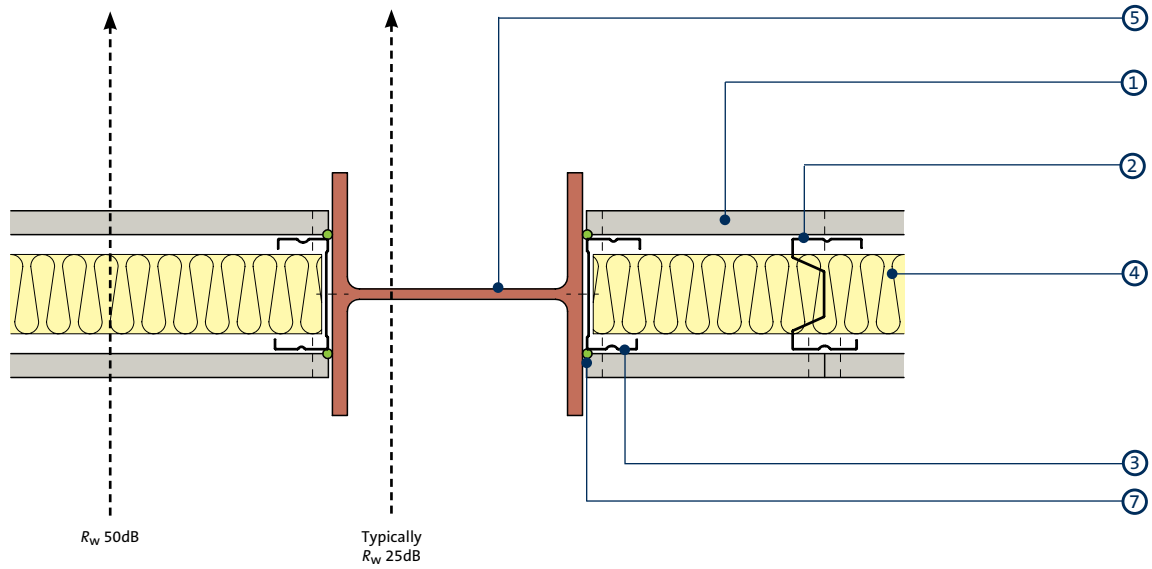

Exposed / painted steel column

5

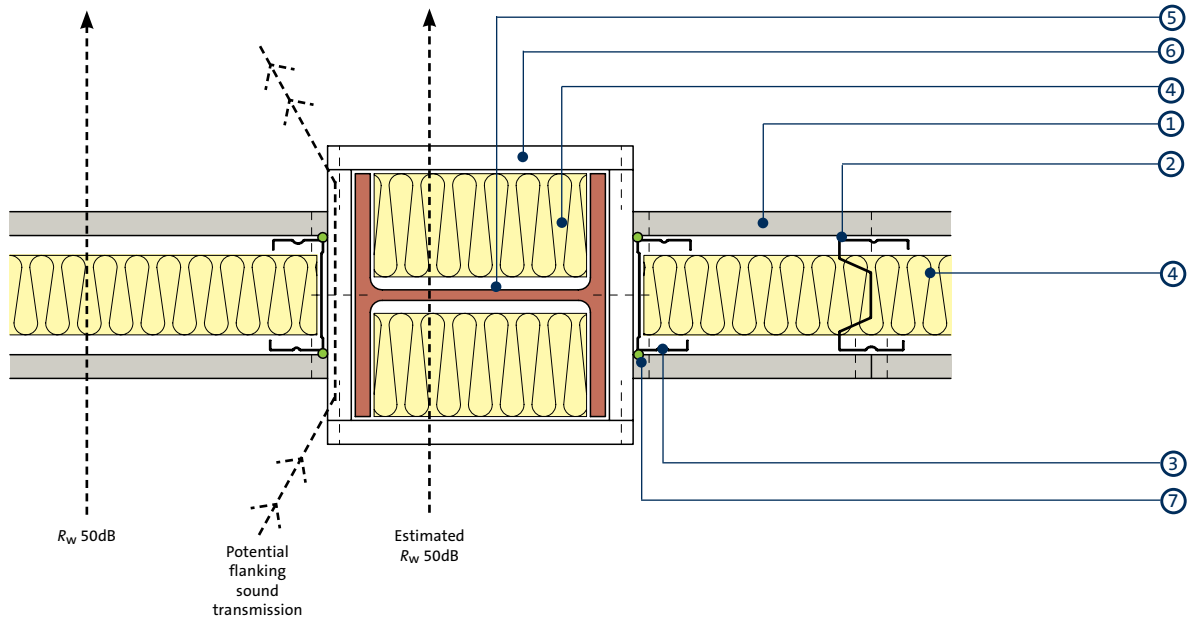

Encased steel column

- 1 Gyproc DuraLine
- 2 Gypframe AcouStud
- 3 Gyprock 'C' Stud
- 4 Isover acoustic insulation

- 5 Structural steel
- 6 Glasroc F FIRECASE
- 7 Gyprock Sealant

Technical performance and principles of system design

Building acoustics (continued)

6

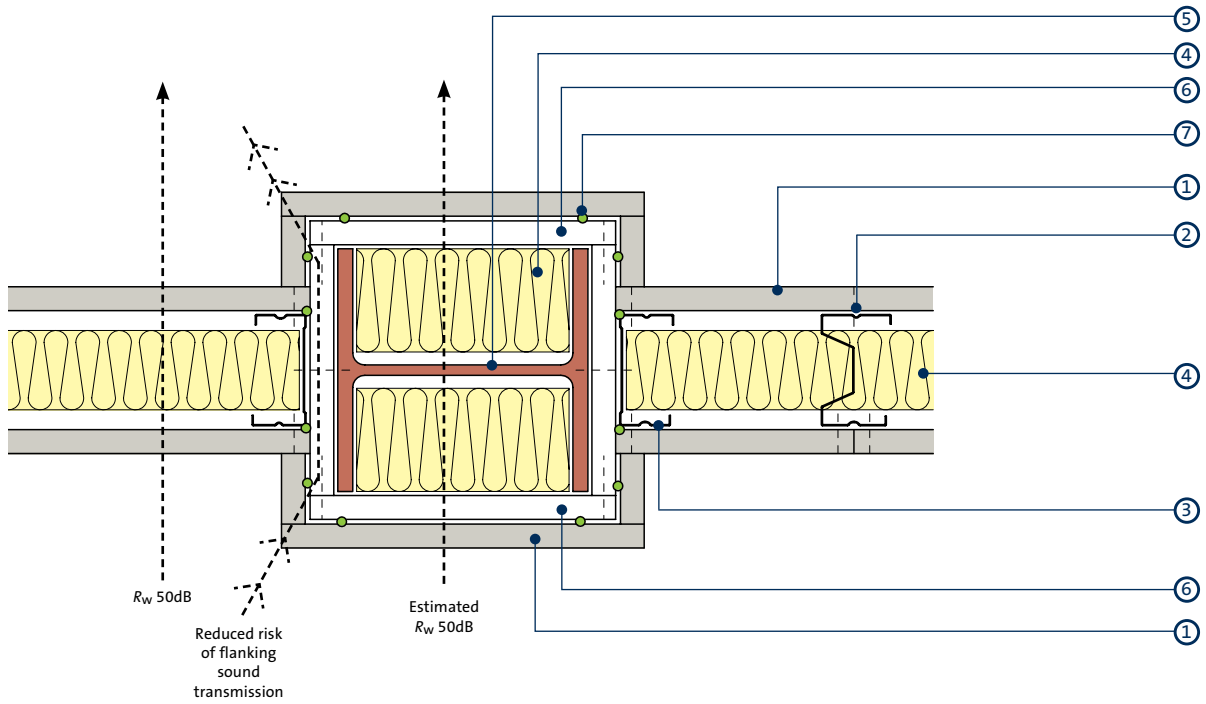

Encased steel column with additional plasterboard lining

7

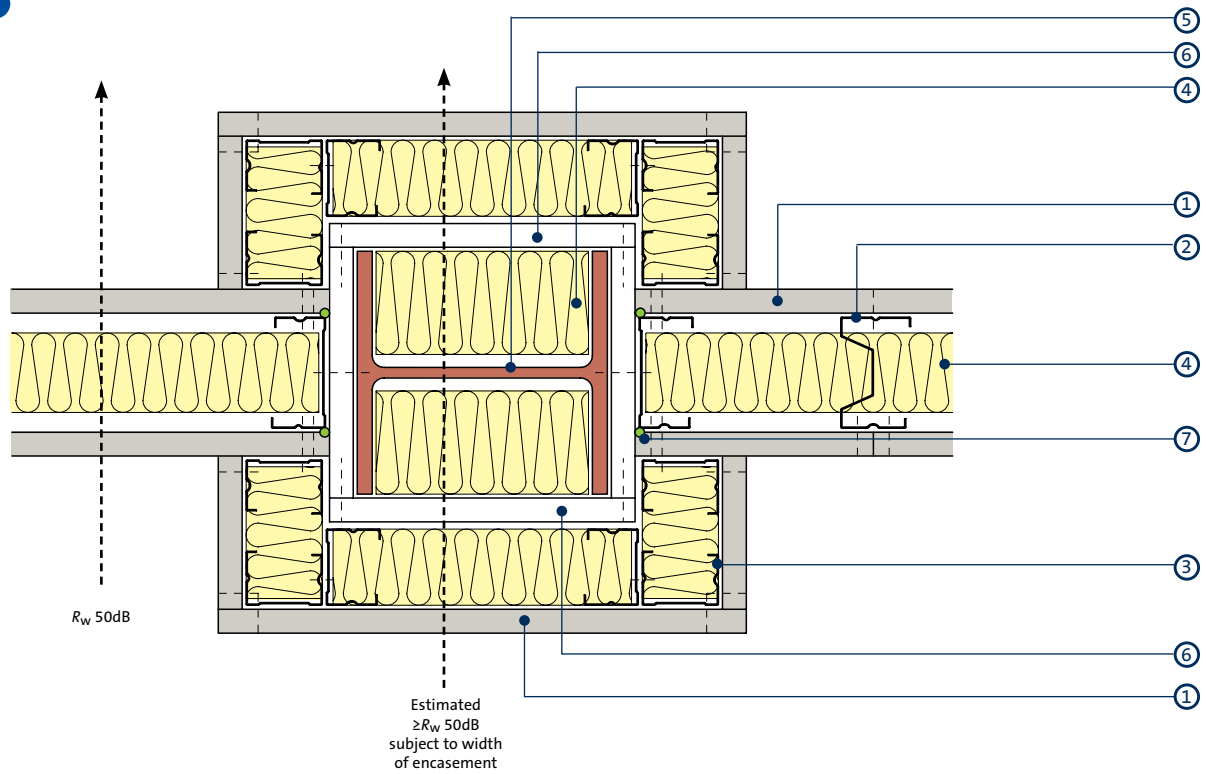

Encased steel column with additional framing, insulation and plasterboard lining

- 1 Gyproc DuraLine
- 2 Gypframe AcouStud
- 3 Gypframe 'C' Stud
- 4 Isover acoustic insulation

- 5 Structural steel
- 6 Glasroc F FIRECASE
- 7 Gyproc Sealant

Technical performance and principles of system design

Building acoustics (continued)

8

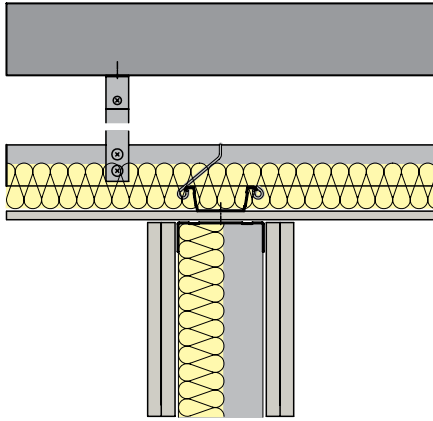

Concealed grid – lined with a single layer of plasterboard and overlaid with insulation = 48dB

9

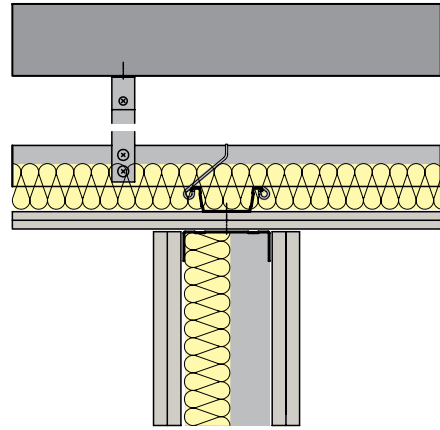

Concealed grid – lined with a double layer of plasterboard and overlaid with insulation = 49dB

10

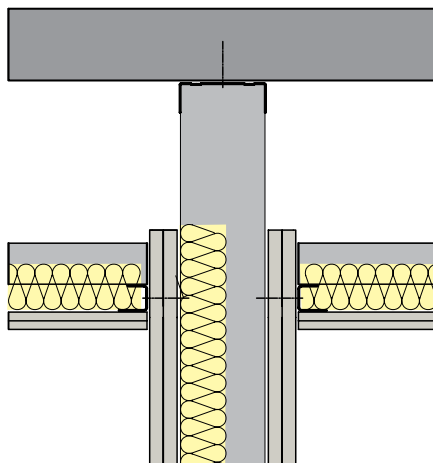

Concealed grid lined with a double layer of plasterboard within each room and overlaid with insulation = 56dB

11

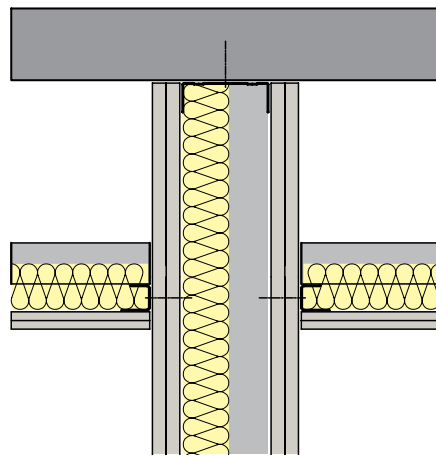

Partition lining continued to the soffit enabling the full potential of the partition to be achieved = 58dB

Technical performance and principles of system design

Building acoustics (continued)

Composite construction

A common mistake made when designing a building is to specify a high performance element and then incorporate a lower performing element within it; for example, a door within a partition.

Where the difference between insulation is relatively small (7dB or less), there needs to be a comparatively large area of the lower insulation element before the overall sound insulation is significantly affected. However, where there is a greater difference in sound insulation performance between the two elements, this would normally result in a greater reduction of overall sound insulation performance.

Table 1 shows the acoustic effect various door types have within a partition system. For example; if a poor performance door is included within a partition, it does not matter if the wall achieves 35dB or 50dB sound insulation, as the net performance will never be greater than 27dB. The lowest performing element will always dominate the overall performance.

Table 1 – The effect various door types have within a partition system

Door construction	Mean sound insulation of partition alone (dB)					
	25	30	35	40	45	50
	Mean sound insulation of partition with doorways accounting for 7% of area (dB)					
Poor performance door with large gaps around the edge	23	25	27	27	27	27
Light door with edge sealing	24	28	30	32	32	32
Heavy door with edge sealing	25	29	33	35	37	37
Double doors with a sound lock	25	30	35	40	44	49

Acoustic privacy

Two main factors affect the level of acoustic privacy achieved when designing a building:

- The sound insulation performance of the structure separating the two spaces
- The ambient background noise present within the receiving room

The ambient background noise level can be a useful tool when designing buildings, as it is possible to mask speech from an adjacent space and hence provide enhanced speech confidentiality, for example a Doctor's consultancy room next to a waiting room. There are a number of commercially available systems to achieve this. It is, however, more common to treat the problem by specifying appropriate levels of sound insulation. A guide to sound insulation levels is given in table 2.

Table 2 – Guide to sound insulation levels for speech privacy

Sound insulation between rooms R_w ¹	Speech privacy
25dB	Normal speech can be overheard
30dB	Loud speech can be heard clearly
35dB	Loud speech can be distinguished under normal conditions
40dB	Loud speech can be heard but not distinguished
45dB	Loud speech can be heard faintly but not distinguished
> 50dB	Loud speech can only be heard with great difficulty

¹ Refer to page 29 for explanations of R_w .

For healthcare and educational environments, acoustic privacy issues are covered in more detail within Health Technical Memorandum (HTM) 05 series and TGD 021-5 from the Department of Education

When designing for residential buildings, the standards of sound insulation given in table 2 are not adequate. Reference should be made to the requirements of Technical Guidance Document E (RoI) or Technical Booklet G (NI).

Ambient noise levels

Along with acoustic privacy, the acceptable level of sound within a room should be assessed. Factors that affect the ambient noise level of a space are:

- The level of external noise
- The level of sound insulation designed into the surrounding structure
- The amount and type of sound absorbing surfaces within the room
- The noise generated by building services

Where control of ambient noise is critical, advice should be sought from an Acoustic Consultant.

For each room there might be a range of levels that are considered acceptable. The designer should select a level appropriate for the particular circumstances.

For this purpose there are a number of methods, including the Noise Rating (NR) system.

The NR system quantifies the level of noise present within a space, taking into account break-in of noise from the adjacent areas, and also the background noise present within the space from ventilation or other building services. Table 3 gives the recommended maximum noise within different activity spaces, using the NR system criteria.

Technical performance and principles of system design

Building acoustics (continued)

Table 3 – Recommended maximum noise rating for various types of room function

Situation	NR ¹ criteria (dB)
Sound studios	15
Concert halls, large theatres, opera houses	20
Large auditoria, large conference rooms, TV studios, hospital wards, private bedrooms, music practice rooms	25
Libraries, hotel rooms, courtrooms, churches, cinemas, medium-sized conference rooms	30
Classrooms, small conference rooms, open-plan offices, restaurants, public rooms, operating theatres, nightclubs	35
Sports halls, swimming pools, cafeteria, large shops circulation areas	40
Workshops, commercial kitchens, factory interiors	45

¹ Refer to ‘Ambient noise levels’ section on the previous page for explanations of NR.

BS 8233:2014 gives guidance on sound insulation and noise reduction in buildings. The standard includes a matrix that can be used to determine the sound insulation requirement of separating partitions once the noise activity, noise sensitivity and privacy requirements for each room and space are established. An example matrix, which can be adapted according to the specific building use, is given in table 4. Each room may be both a source and a receiving room. Where adjacent rooms have different uses, the worst case sound insulation should be specified.

Table 4 – Example on-site sound insulation matrix ($D_{nT,w}$ dB)

Privacy	Activity noise of source room	Noise sensitivity of receiving rooms		
		Low sensitivity	Medium sensitivity	Sensitive
Confidential	Very high	47	52	57 ²
	High	47	47	52
	Typical	47	47	47
	Low	42	42	47
Moderate	Very high	47	52	57 ²
	High	37	42	47
	Typical	37	37	42
	Low	No rating	No rating	37
Not private	Very high	47	52	57 ²
	High	37	42	47
	Typical	No rating	37	42
	Low	No rating	No rating	37

² $D_{nT,w}$ 55dB or greater is difficult to obtain on-site and room adjacencies requiring these levels should be avoided wherever practical. Refer to page 29 for explanations of $D_{nT,w}$.

Sound absorption

Sound absorption is the term given to the loss of sound energy on interaction with a surface. Sound absorbent surfaces are used to provide the correct acoustic environment within a room or space. The choice of material will be influenced by its acoustic efficiency, appearance, durability and fire protection.

By converting some of the sound energy into heat, sound absorbing materials will also help sound insulation because less noise will be transmitted to other rooms. However, this reduction in noise is very small when compared with the potential reduction due to sound insulation. Sound absorption is therefore never a substitute for adequate sound insulation.

Reverberant energy

Reverberation is the persistence of sound in a particular space after the original sound is removed. A reverberation, or reverb, is created when a sound is produced in an enclosed space causing a large number of echoes to build up and then slowly decay as the sound is absorbed by the walls, ceilings, floor and air. The length of this sound decay is known as reverberation time and can be controlled using sound absorbing materials. The appropriate reverberation time for a space will be dependent on the size and function of the space. Examples of typical reverberation times are given in table 5.

Table 5 – Typical reverberation times

Type of room / activity	Reverberation time (mid frequency)
Swimming pool	<2.0 seconds
Dance studio	<1.2 seconds
Large lecture theatre	<1.0 seconds
Small lecture room	<0.8 seconds
Primary school playroom	<0.6 seconds
Classroom for hearing impaired	<0.4 seconds

Speech clarity

Speech clarity (intelligibility) is now recognised as essential in helping pupils in an educational environment to achieve their full potential.

Research has shown that pupils who cannot understand clearly what the teacher is saying have a tendency to ‘switch off’ – limiting their own educational opportunities and creating additional stress for teachers. In a typical classroom with the teacher at one end, sound reaches the pupils both directly from the teacher and via reflections from the ceiling, walls and floor. Refer to figure 12.

Pupils at the front will generally be able to understand what the teacher is saying, whilst pupils at the back and sides of the room receive a mixture of both direct speech and reflected sound, making it difficult to identify the teacher’s words.

Reverberation time alone cannot be relied upon to deliver a suitable environment for good speech intelligibility. In any situation where speech communication is critical, e.g. conference room, lecture theatre or classroom, it is necessary to design the space appropriately using a mixture of sound reflective and sound absorbing surfaces.

Technical performance and principles of system design

Building acoustics (continued)

12

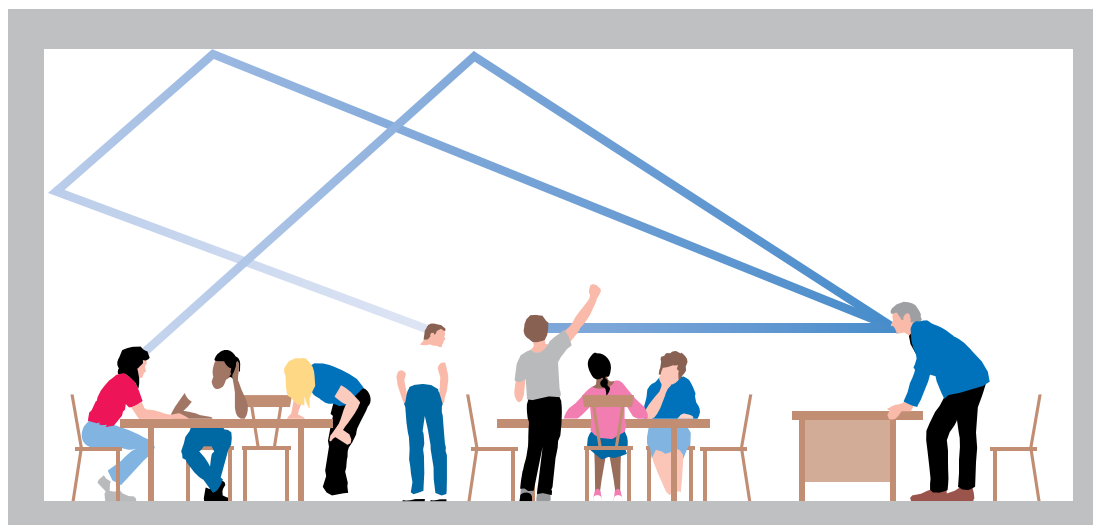

Sound transmission in a typical classroom

Rating methods

Sound insulation rating methods

The sound insulation rating methods that follow are defined in: *BS EN ISO 717: Part 1: 2013 (airborne)* and *BS EN ISO 717: Part 2: 2013 (impact)*.

R_w

This single figure rating method is used for laboratory airborne sound insulation tests. The figure indicates the amount of sound energy being stopped by a separating building element when tested in isolation in the absence of any flanking paths.

$D_{nT,w}$

This single figure rating method gives the airborne sound insulation performance between two adjacent rooms within a building as measured on site. The result achieved is affected not only by the separating element, but also by the surrounding structure and junction details.

C_{tr}

The C_{tr} adaptation term is a correction that can be added to either the R_w (laboratory) or $D_{nT,w}$ (site) airborne rating.

The term has been adopted within Building Regulations Technical Booklet G (NI). The C_{tr} term is used because it targets the low frequency performance of a building element and in particular the performance achieved in the 100 – 315 Hz frequency range. This term was originally developed to describe how a building element would perform if subject to excessive low frequency sound sources, such as traffic and railway noise. Performance tables in

this book present relevant sound insulation values both in R_w terms but also in the C_{tr} adapted form. This rating is expressed as $R_w + C_{tr}$ and allows the Acoustic Consultant to critically compare performances. The rating method mainly considers low frequency performance, and has not been universally welcomed due to the difficulties in measuring low frequency performance.

Consequently, within separating constructions, Gyproc can offer enhanced specifications that meet the low frequency performance of the C_{tr} rating whilst also offering good mid and high frequency sound insulation.

$L_{n,w}$

This single figure rating method is used for laboratory impact sound insulation tests on separating floors. The figure indicates the amount of sound energy being transmitted through the floor tested in isolation, in the absence of any flanking paths. With impact sound insulation, the lower the figure the better the performance.

$L'_{nT,w}$

This single figure rating method gives the impact sound insulation performance for floors. The figure indicates the sound insulation performance between two adjacent rooms within a building as measured on site. The result achieved is affected not only by the separating floor but also by the surrounding structure, e.g. flanking walls and associated junction details.

Technical performance and principles of system design

Building acoustics (continued)

$D_{n,c,w}$ (as defined in *BS EN ISO 717-1:1997*)

This single figure laboratory rating method is used for evaluating the airborne sound insulation performance of suspended ceilings. Laboratory tests simulate the room-to-room performance of the suspended ceiling when a partition is built up to the underside of the ceiling with sound transmitted via the plenum.

Sound absorption rating methods

The following ratings are calculated in accordance with *BS EN ISO 11654: 1997*.

Sound absorption coefficient, α_s

Individual sound absorption figures quoted in one-third octave frequency bands are used within advanced modelling techniques to accurately predict the acoustic characteristics of a space. The coefficient ranges from 0 (total reflection) through to 1 (total absorption).

Practical sound absorption coefficient, α_p

A convenient octave-based expression of the sound absorption coefficient; commonly used by Acoustic Consultants when performing calculations of reverberation times within a building space.

Sound absorption rating, α_w

A single figure rating used to describe the performance of a material. The single figure rating can have a modifier added to indicate if the spectral shape is dominated by a particular frequency range

- L – absorption is predominantly in the low frequency region
- M – absorption is predominantly in the mid frequency region
- H – absorption is predominantly in the high frequency region

The absence of a letter following the rating indicates that the absorber has no distinct area of sound absorption and has an essentially flat spectral shape.

Noise Reduction Coefficient, NRC

Whilst the sound absorption performance of a ceiling system can be expressed as an NRC, this does not always accurately reflect the product performance. An NRC value is the arithmetic mean of the absorption coefficients across a limited frequency range; this means that it will hide extremes in performance. For instance, a ceiling tile may be a very efficient absorber at high frequencies but very poor at low frequencies, and the NRC value will not reflect this. To optimise the room acoustics the more accurate sound absorption rating, α_w , should be used.

Principles of lightweight construction

Typically the average sound insulation of a material forming a solid partition is governed by its mass; the heavier the material, the greater its resistance to sound transmission. To increase the sound insulation of a solid partition by approximately 4dB, the mass must be doubled. This is known as the empirical mass law.

For example; a 100mm solid block wall of average mass 100kg/m² will have an approximate R_w value of 40dB, whereas a 200mm solid wall of the same material would have an R_w value of 44dB.

Increasing mass is a very inefficient way of achieving sound insulation and one of the advantages of using lightweight cavity partitions and walls is that better than predicted sound reduction values can be achieved. This is why this construction is commonly used in auditoria, e.g. **GypWall AUDIO**. Lightweight systems versus the mass law shows how lightweight systems consistently exceed mass law predictions. This demonstrates that adding mass is not always the best method to satisfy acoustic design requirements and that, lightweight systems, if correctly designed, can provide very effective acoustic solutions. Refer to figure 13.

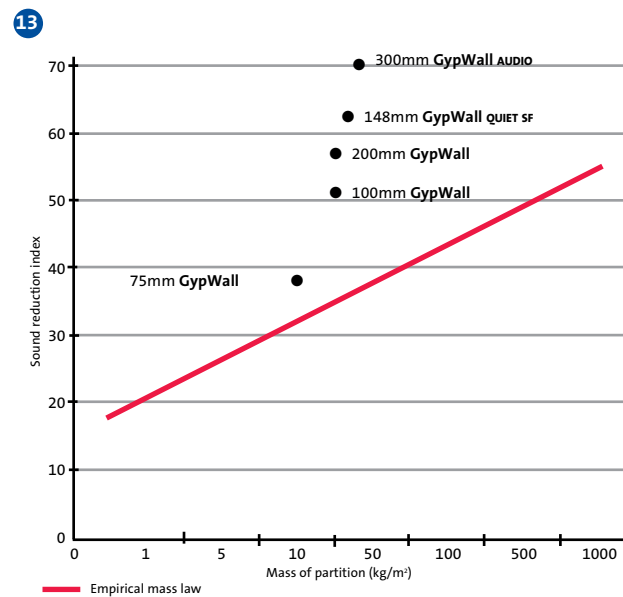

Lightweight systems versus the mass law

Acoustic performance is commonly expressed as a decibel (dB) value. The logarithmic scale of decibels provides a simple way to cover a large range of values and show them as a convenient number. Unfortunately the decibel scale can create confusion especially when comparing alternative systems as the difference in acoustic performance can appear to be quite small. In reality an increase of 6dB is equivalent to a doubling of the acoustic performance of the system.

Technical performance and principles of system design

Building acoustics (continued)

A simple stud partition, for example, can have an R_w rating of 6dB better than predicted by the mass law. In this case, the maximum sound insulation obtainable will be governed by the transmission of energy through the stud frame. The use of other frame types, or configurations, can result in even better insulation. If Gyproc plasterboard or Gyproc specialist boards are fixed to a timber stud frame using a flexible mounting system, such as Gypframe RB1 Resilient Bar, or a more flexible frame is used, for example, Gypframe studs and channels, sound transmission through the framing is minimised and performance significantly better than the mass law prediction can be achieved.

The use of two completely separate stud frames can produce even better results. In this case, the maximum energy transmission is through the cavity between the plasterboard linings. The air in the cavity can be considered as a spring connecting the linings, which allows the passage of energy. The spring will have some inherent damping, which can be significantly increased by the introduction of a sound absorbing material, such as mineral wool, positioned in the cavity. The increased damping of the air-spring results in a reduced coupling between the plasterboard linings and a consequent decrease in sound transmission. Air-spring coupling becomes less significant as the cavity width increases. In practice, cavities should be as wide as possible to insulate against low frequency sounds.

Two important effects; resonance and coincidence, occur in partitions and walls. These are governed by physical properties such as density, thickness and bending stiffness, and can result in a reduction in sound insulation at certain frequencies.

In lightweight cavity constructions, resonance and coincidence effects can be decreased by the use of two or more board layers. A simple way of increasing the sound insulation performance of a single layer metal stud partition is to add an additional layer of plasterboard to one, or both,

sides. This will increase the sound insulation performance by approximately 6dB or 10dB respectively.

Acoustic benefits of applying Gyproc Finish Plasters to certain GypWall partition systems

Applying 2mm Gyproc Finish Plasters to both sides of certain GypWall partitions has a positive effect on the sound insulation performance. This is effective on partitions that are limited by their high frequency performance (coincidence region).

The application of Gyproc Finish Plasters also adds mass to the partition which has a positive effect on the mid-frequency of the spectrum.

Figure 14 shows an example of a partition that will be positively affected by skim finish using Gyproc Finish Plasters.

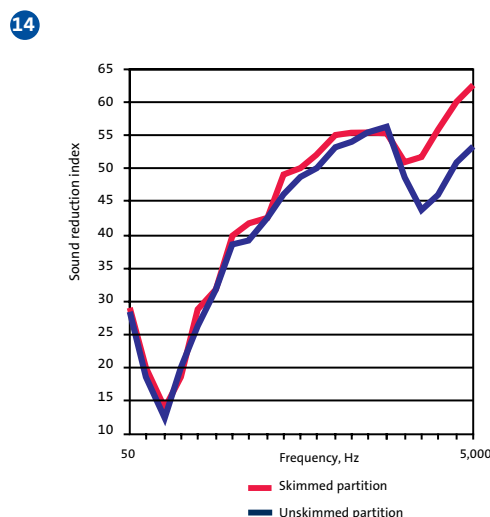

Acoustic benefits of applying Gyproc Finish Plasters to certain GypWall partitions

Table 6 – TGD E: Sound Insulation Requirements (RoI)

Separating construction	Airborne sound insulation $D_{nT,w}$ dB	Impact sound insulation $L'_{nT,w}$ dB
Walls	53 (min)	-
Floors (including stairs with separating function)	53 (min)	58 (max)

Table 6a – TB G: Sound Insulation Requirements (NI)

Separating construction	Airborne sound insulation $D_{nT,w}+C_w$ dB	Impact sound insulation $L'_{nT,w}$ dB
New dwellings		
Walls	43/45 (dwellings only)	-
Floors and stairs	45	62
Dwellings formed by material change of use		
Walls	43	-
Floors and stairs	43	64

Technical performance and principles of system design

Building acoustics (continued)

Refer to system sections within 'Partitions' where systems positively affected by the application of Gyproc Finish Plasters are shown. Systems with additional performance will show two acoustic figures in the tables – Sound insulation performance for partitions finished using jointing or plaster skim and sound insulation performance for partitions with a 2mm skim finish of Gyproc Finish Plasters.

Legislation and guidance

Building Regulations – Residential Buildings

Building Regulations Technical Guidance Document E (RoI) or Technical Booklet G (NI) gives guidance on how to provide reasonable standards of sound insulation in dwellings and other residential buildings. They cover both new-build and refurbishment or conversion, and include minimum standards of performance.

Complying with the regulations

In Ireland, housebuilders and residential developers can demonstrate compliance of separating walls and floors for new-build houses and apartments using manufacturers' proprietary systems or Building Regulations Example / Guidance and verifying by Pre-Completion Testing

Robust Details (Northern Ireland)

To avoid Pre-Completion Testing for new-build houses and flats the Home Builders Federation (HBF) developed a series of Robust Details. These forms of construction have been designed and site tested to ensure that they deliver a standard of sound insulation on site to meet the minimum requirements of TB G. The Building Regulations have been amended to allow Robust Details to be used as an alternative to Pre-Completion Testing.

If you are following the Robust Detail route, you must register each plot, with the details you intend to use, and pay a fee. You will then be given a registration certificate to hand to your building control authority before work starts. Robust Details Ltd administers the scheme.

If you are building to the Irish Green Building Council's Home Quality Rating Tool, Robust Details may entitle you to additional credits under the Health and Wellbeing category – check the Robust Details Handbook for the most up-to-date details.

Sound Absorption

Section 5.2.2 of TGD E (2014) and Section 7 of TB G (2012) cover reverberation noise in the common internal parts of buildings containing flats or rooms for residential purposes. The regulations state that "the common internal parts of buildings which contain flats or rooms for residential purposes shall be designed and constructed in such a way as to prevent more reverberation around the common parts than is reasonable".

The regulations give two methods of calculating the amount of absorption required in any communal areas. The two methods are referred to as 'Method A' and 'Method B'.

AD E specifies sound absorption in terms of a class of absorber. There are five classes (A through to E) with Class A signifying the products with the highest level of sound absorption. However, to comply with method A, only class C or D is required. The values ascribed to the different classes are given in table 7.

Table 7 – Absorption class

Sound absorption class	α_w
A	0.90, 0.95, 1.00
B	0.80, 0.85
C	0.60, 0.65, 0.70, 0.75
D	0.30, 0.35, 0.40, 0.45, 0.50, 0.55
E	0.15, 0.20, 0.25
Unclassified	0.00, 0.05, 0.10

For more information, refer to Building Regulations; Section 5.2.2 of TGD E (2014) and Section 7 of TB G (2012): Reverberation in the common internal parts of buildings containing flats or rooms for residential purposes.

Example constructions

These are constructions developed to repeatedly achieve required design performance levels, if built correctly with correctly designed flanking details. Use of these constructions does not guarantee regulatory performance levels will be achieved, and the onus is therefore on the housebuilder to demonstrate compliance by Post-Completion Testing on site.

Other constructions

These include manufacturers' proprietary solutions and new, or innovative, constructions not considered to be 'Example Constructions'. Again, the onus is on the housebuilder to demonstrate compliance by Post-Completion Testing.

Post-Completion Testing

Post-Completion Testing is carried out when the building is complete, with doors, access hatches and windows fitted.

If a test fails due to the construction of the separating floor or associated flanking elements, other untested

Technical performance and principles of system design

Building acoustics (continued)

rooms may be affected. This will result in additional testing requirements. It may be prudent to seek specialist advice to identify and remedy any problems.

Acoustic design of schools

Each room or other space in a school building shall be designed and constructed in such a way that it has the acoustic conditions and the insulation against disturbance by noise appropriate to its intended use.

To satisfy this requirement, it is recommended that buildings comply with the guidance TGD 021-5 Acoustic Performance of Schools from the Department of Education in Rol and Building Bulletin 93 (BB93) Acoustic design of schools, a design guide for Northern Ireland.

BB93 was written by the Department for Children, Schools and Families (DCSF), formerly the Department for Education and Skills (DfES), and provides a regulatory framework for the acoustic design of schools; including sound insulation between spaces, ambient noise levels and optimum reverberation times for various spaces within educational buildings.

For more information refer to our **Education Sector Guide**, available from the Gyproc Technical Department.

Health and Technical Memorandum HTM 08-01 Acoustics – Healthcare Buildings

Good acoustic design is fundamental to the quality of healthcare buildings. The control of unwanted noise improves patient privacy, dignity and sleep patterns; all key conditions for healing. Good acoustic design also increases the morale and comfort of healthcare professionals.

HTM 08-01 covers the acoustic design criteria that are important for healthcare premises and contains a method of determining the level of sound insulation required between adjacent spaces in a healthcare environment. The document also gives recommended reverberation times for various types of space.

Hotels and Hospitality: Acoustic Standards

The Fáilte Ireland Guest House Classification Scheme requires that bedrooms, the toilets and bathrooms serving them, and the corridors off which they shall open shall be separated from each other by walls or partitions, floors and ceilings and having an acoustic attenuation of 50 dB.

BS 8233 advises a figure of 43 dB DnT,w + C_{tr} (i.e. a site tested result factoring in additional low frequencies) but also 60 dB DnT,w between Bedrooms and other common areas, excluding corridors.

BS 8233 – Sound insulation and noise reduction for buildings

BS 8233 provides guidance on acoustic ratings appropriate to a variety of different building types. It is applicable to the design of new buildings, or refurbished buildings undergoing a change of use. It deals with control of noise from outside the building, noise from plant and services within it, and room acoustics for non-critical situations.

A full revision of the standard, launched in 2014, includes changes which reflect:

- Legislative framework revision since publication of the 1999 edition
- Revisions to Building Regulations
- The publication of specialist documents for specific sectors, such as healthcare and education
- A reappraisal of the tabular content with respect to setting targets for various classes of living space in the light of research findings
- The need to transfer some of the more detailed information from the main text to annexes
- Requirements for offices

Designing for on-site performance in Northern Ireland

Achieving a $D_{nT,w} + C_{tr}$ performance on site

The C_{tr} rating method puts increased emphasis on the low frequency region of the spectrum. For lightweight construction this means a significant change in some of the design principles. For partitions, the cavity should be as large as possible and double layers of plasterboard should be used.

For masonry walls lined with lightweight panels, cavities with a depth of less than 60mm should be avoided. Two linings, with small, identical sized cavities either side of a solid masonry wall, should not be specified. These cavities can interact and cause a significant downgrade in the critical low frequency zone. If a small cavity is required, one side only should be lined with a double layer of plasterboard. Optimum performance is achieved by lining one side only and having a cavity depth of at least 85mm.

- ▶ Refer to C02. S01. P41 for more information on service voids.

Technical performance and principles of system design

Building acoustics (continued)

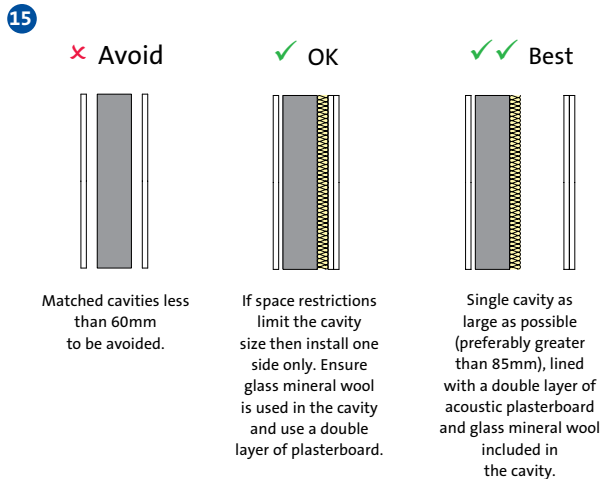

Optimum design of panel linings for C_{tr}

To increase the sound insulation of new or existing masonry walls, **Gyplyner** wall lining systems can be used in conjunction with Isover acoustic insulation and Gyproc plasterboard. The cavity depth of the **Gyplyner** lining should be as large as possible, and small, identical sized cavities to either side of the wall should be avoided.

For lightweight separating floors, partially de-coupling the plasterboard ceiling from the floor structure, using Gypframe RB1 Resilient Bars, helps to achieve the required performance. Floating floor treatments, for example timber battens, should have a cavity depth of at least 70mm to avoid low frequency resonance effects in the critical low frequency zone. Performance can be further enhanced by specifying Gyproc Plank within the walking surface.

Floating floor and resilient bar ceiling systems should be tested in a UKAS laboratory to ensure good low frequency performance.

A method of determining the achievable site $D_{nT,w} + C_{tr}$ performance is to refer to a laboratory $R_w + C_{tr}$ rating. Depending on the wall specification, a minimum drop of 4dB is typical when comparing $R_w + C_{tr}$ and $D_{nT,w} + C_{tr}$. However, we recommend that a safety margin of + 9dB should be used to reduce the risk of failure to comply with Building Regulations. This assumes all flanking paths are appropriately detailed, ideal site lay-out exists and a high quality of workmanship is applied.

For purpose-built dwelling houses and flats requiring $D_{nT,w} + C_{tr}$ 45dB for separating walls, separating floors and stairs, we recommend specifications capable of achieving $R_w + C_{tr}$ 54dB.

For purpose-built rooms for residential purposes requiring $D_{nT,w} + C_{tr}$ 43dB for separating walls, and $D_{nT,w} + C_{tr}$ 45dB for separating floors and stairs, we recommend specifications capable of achieving $R_w + C_{tr}$ 52dB for separating walls, and $R_w + C_{tr}$ 54dB for separating floors and stairs.

For dwelling houses, flats and rooms for residential purposes formed by material change of use requiring $D_{nT,w} + C_{tr}$ 43dB for separating walls, separating floors and stairs, we recommend the use of specifications that are capable of achieving $R_w + C_{tr}$ 52dB.

Achieving a $D_{nT,w}$ performance on site

Similar to the principles of achieving a $D_{nT,w} + C_{tr}$ performance on site, a realistic safety margin should be incorporated when designing to meet a $D_{nT,w}$ requirement, to reduce the risk of failure. We recommend a safety margin of + 7dB when comparing site performance, $D_{nT,w}$ to laboratory performance, R_w .

For example, to comply with Scottish Technical Handbook Section 5 in Scotland for a requirement of $D_{nT,w}$ 56dB, a system capable of achieving R_w 63dB under laboratory conditions should be specified.

Achieving a $L'_{nT,w}$ performance on site

A minimum reduction of 5dB is typical when comparing site performance, $L'_{nT,w}$ to laboratory performance, $L_{n,w}$. However, when designing separating floors to reduce the risk of impact sound flanking transmission, in particular timber joist, the walking surface should be de-coupled from the joists, for example using **GypFloor SILENT** or a batten floating floor system. This is in addition to the de-coupling of the ceiling, using **CasoLine MF** ceiling or Gypframe RB1 Resilient Bar, for example.

Therefore, in some cases the safety margin in the laboratory for timber joist separating floors is likely to be in the region of + 10dB, rather than the typical minimum + 5dB for concrete floors.

The key points for consideration when designing to meet any acoustic performance requirement are below:

- Inappropriate detailing of flanking conditions can greatly reduce the level of performance of the system from that achieved in the laboratory. Refer to figures 4-7 for more information
- For separating wall and floor constructions to be fully effective, care must be taken to correctly detail the junctions between the separating wall or floor and associated elements such as external walls, other separating elements and penetrations or door openings, etc.
- If junctions are incorrectly detailed then the acoustic performance will be limited and Building Regulations requirements will not be achieved in practice
- Pre-Completion Testing exposes poor flanking details and inadequate separating wall and floor specifications. Good flanking detailing and specifications that provide a reasonable margin of safety on site are therefore essential.

Technical performance and principles of system design

Building acoustics (continued)

Examples of practical solutions

Gypframe AcouStuds

Gypframe AcouStuds are metal stud sections optimised to give enhanced sound insulation performance. These unique shaped studs are used for increased acoustic performance. Gypframe AcouStuds can be used to upgrade the acoustic performance of 70mm, 92mm and 146mm wall systems.

Figure 16 shows the performance improvement possible using acoustic stud technology compared with a standard 'C' stud of the same cavity dimension.

GypWall STAGGERED

GypWall STAGGERED features staggered studs that are located within a head and base channel by means of retaining clips. This arrangement means there is limited connection through the framework to the plasterboard face on the opposite side of the partition. The system design enables a higher level of sound insulation to be achieved with modest cavity sizes.

Figure 17 shows the improvements possible using a staggered stud arrangement compared to a standard GypWall 'C' stud partition with the same partition cavity size.

GypWall QUIET SF

GypWall QUIET SF utilises Gypframe RB1 Resilient Bars to partially de-couple the plasterboard linings from the partition stud frame, leading to enhanced levels of sound insulation.

Figure 18 shows the improvements possible when including Gypframe RB1 Resilient Bar on one or both sides of a standard Gypframe 70mm 'C' Stud partition.

GypWall AUDIO and GypWall QUIET IWL

The most acoustically effective wall designs are twin frame walls. Minimal or no bridging between the plasterboard linings and the increased cavity size allows optimum performance from the wall.

Figure 19 shows the difference achievable by using a twin framed wall approach as opposed to a standard GypWall 'C' stud partition. The plasterboard linings and insulation are the same for both partitions and the key difference is the overall partition thickness – typically 211mm for the standard partition and 300mm for the twin framed option. With this type of design, further improvements in performance can be achieved by increasing the cavity size and/or increasing the board specification.

Gypframe RB1 Resilient Bar (ceilings)

Gypframe RB1 Resilient Bar is an engineered metal component used predominantly with lightweight separating floors to de-couple the ceiling from the floor structure and thereby improve the airborne sound insulation performance of the separating floor.

The value of this component is recognised in Robust Details, where all lightweight floor solutions feature resilient bars to partially de-couple the ceiling from the floor structure.

Figure 20 shows the substantial performance improvements achievable for airborne sound insulation when Gypframe RB1 Resilient Bar is utilised instead of a directly fixed ceiling.

Floating floor treatment

Floating floor treatments are used with both lightweight and concrete separating floors to de-couple the walking surface from the floor structure and thereby improve both the airborne and impact sound insulation performance of a separating floor.

The value of this technique is recognised in Robust Details, and is currently featured in a number of separating floor solutions.

Sound insulating dry linings

In designing for sound insulation, care should be taken to ensure that flanking transmission via the associated structure does not downgrade the performance of the partition or wall to a level below that required in use. This applies especially when a lightweight partition or wall is constructed in a masonry building. Care should therefore be taken to ensure the associated structure is able to achieve the level of sound insulation required.

The performance of sound resisting floors of timber joist or lightweight concrete construction, supported on or flanked by conventionally finished masonry walls, can be adversely affected by flanking transmission in the walls. This effect can be significantly reduced by the application of a Gyplyner wall lining system, to the flanking walls.

Lining treatments can also be beneficial in refurbishment work when applied to flanking walls of new or existing sound resisting walls.

► Refer to C07. S01. P455 – Linings introduction.

Technical performance and principles of system design

Building acoustics (continued)

16

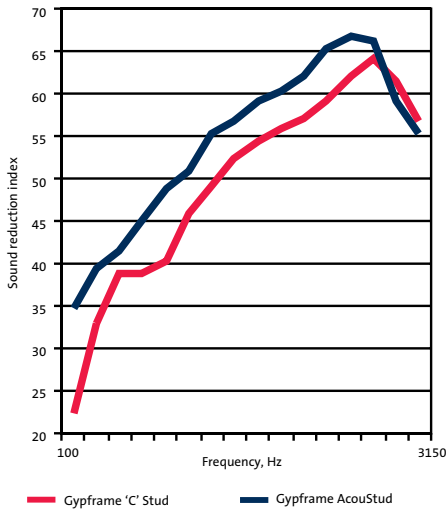

Acoustic benefits of Gypframe AcouStuds

17

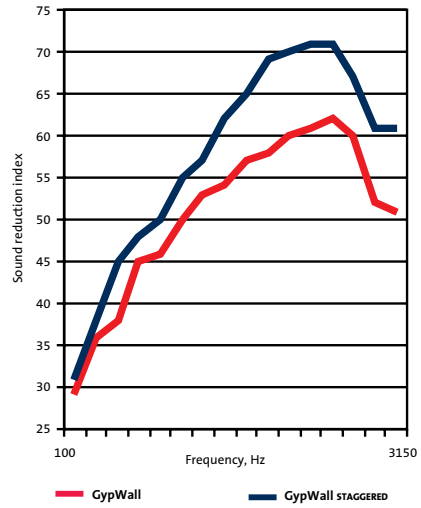

Acoustic benefits of staggered studs

18

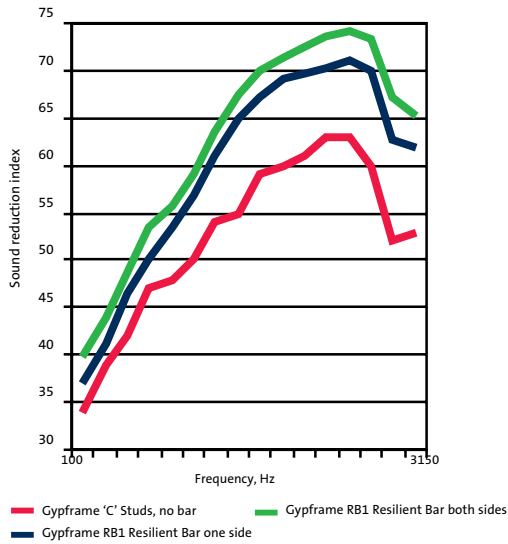

Acoustic benefits of resilient bars (partition)

19

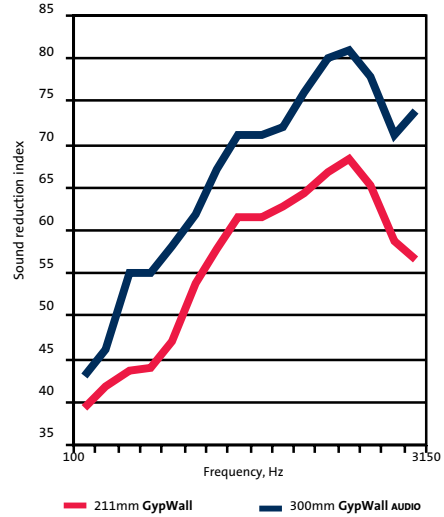

Acoustic benefits of twin stud framework

20

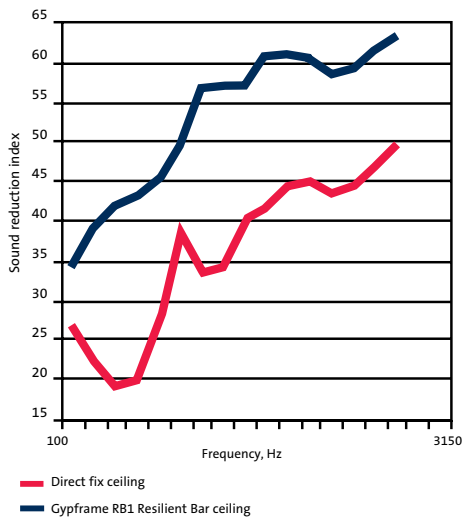

Airborne sound insulation benefit of resilient bars (ceiling)