

GypWall SUPERIOR

The Revolutionary New Plasterboard





Habito Board

The latest addition to the Gyproc performance board range, Gyproc Habito provides enhanced acoustic, impact resistance and for the first time, fixing capability. Suitable for direct decoration.

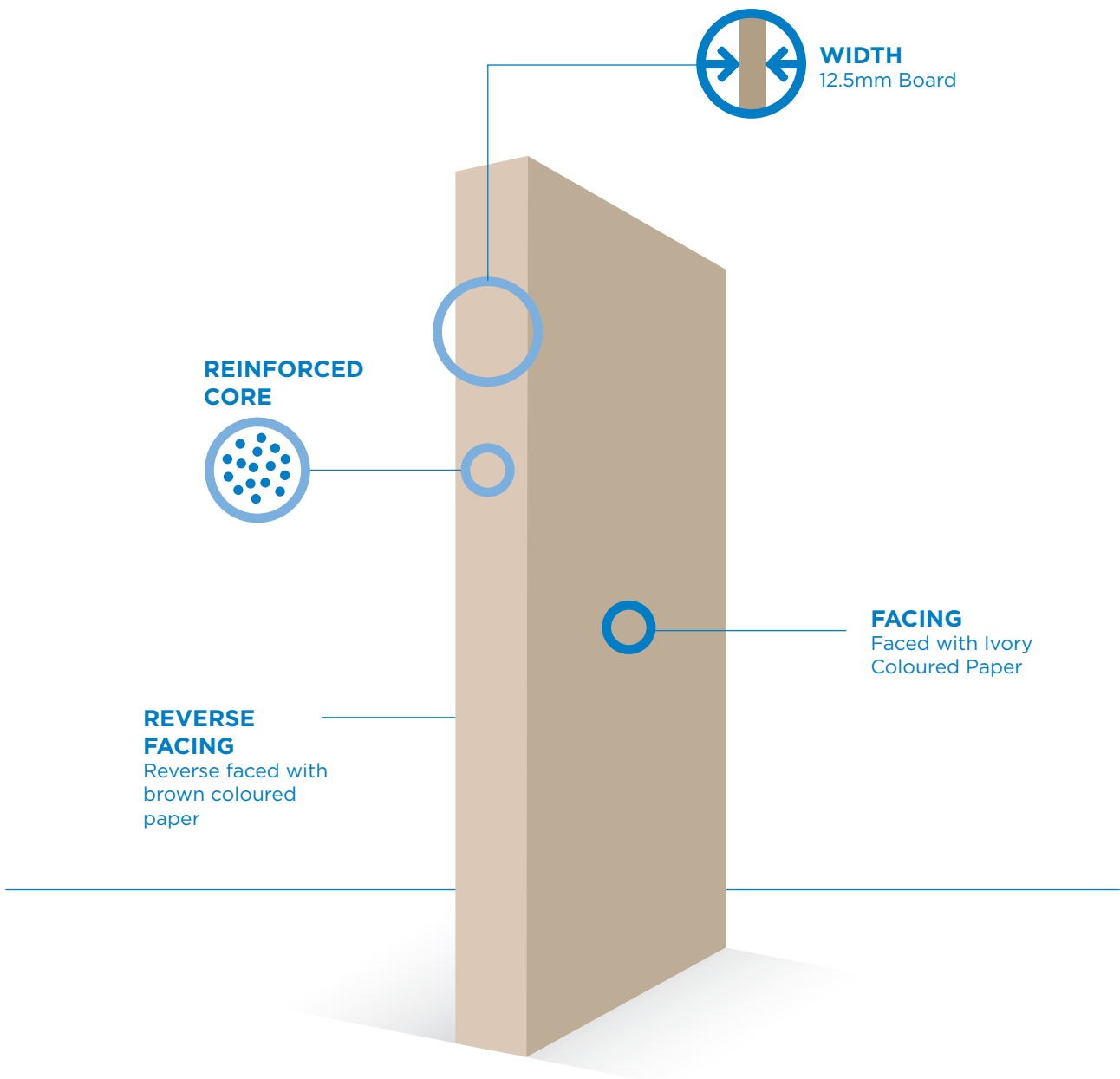

ACOUSTIC



IMPACT



FIXING STRENGTH



APPLICATION

Designed for use in wall and partitions systems where greater levels of sound insulation, impact/duty and fixing capability are required.

Fixing into Gyproc Habito

Determine the correct screw to use

We recommend that you use a woodscrew for fixing items into Gyproc Habito. Woodscrews are commonly stocked in DIY stores.

Length

It is important to select a screw length which is appropriate to what you are fixing. You should ensure that the fixing is long enough so that the screw penetrates the back of the board by 8mm. It is important that the screw has thread over the full length within the board thickness as shown on the right.

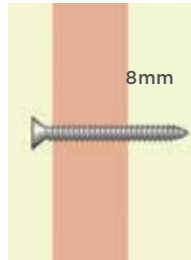

Grade of screw

Woodscrews are available in different classifications e.g 5.0mm, 6.0mm etc. The load that the fixing can support, when screwed into Gyproc Habito, is governed by the screw classification. A 5.0mm woodscrew can support a load of up to 15kg per fixing.

Classification	Metric Equivalent	Loading (kg)
No. 6	3.5mm	12.4
No. 8	4.0mm	12.9
No. 10	5.0mm	15
No.12	6.0mm	15

Load Types

Gyproc Habito has been tested with a variety of loads but it is important to consider the different load types and suitable fixings when fixing an item to any plasterboard. The table below provides an example of possible load types and the recommended fixings (subject to maximum load criteria), for further advice you can contact our Technical Support Department.

Load Type	Understanding the Terminology	Recommended Fixing for Habito**
Static Load	Where weight is reasonably consistent after the item is fixed into position e.g. Mirrors, paintings etc.	5mm Woodscrew
Cyclical Load	Where loading on the fixture increases and decreases e.g. the loading and unloading of kitchen cabinets, shelves etc.	5mm Woodscrew*
Dynamic/ Live Load	The nature of the item being fixed means that it will have a high level of additional interaction e.g. Handrails etc.	Cavity Anchor

* If concerned about potential for accidental dynamic/ live loading, then use of a cavity anchor is recommended

** Fixings are subject to maximum (pull out) loading weight

Fixing devices and typical safe working loads on Gyproc Habito



	Woodscrew 5mm	M5/12 Cavity Anchor	M5/25 Cavity Anchor	M4 Spring Toggle
Board Types	Typical SWL (kg)	Typical SWL (kg)	Typical SWL (kg)	Typical SWL (kg)
12.5mm Gyproc Habito	15	37	47	42
2 x 12.5mm Gyproc Habito	34	N/A	81	53

It is important to ensure that the drylining system specified is capable of supporting the loads, particularly if installing multiple fixtures.

It is important that you do not over tighten fixings into Gyproc Habito. Any material you are fixing into has a limit to how much a fixing can be tightened. Once you feel resistance to tightening a screw stop. If you over tighten the screw, you will start to strip the core of the product, removing the ability for the screw to grip into the board. If you do over tighten the fixing it will turn without any resistance. In this case you will need to fit a cavity fixing, as you have created a hole through the Habito Board.

Installation

When installing Gyproc Habito, Habito Winged screws must be used and installed using an Impact Driver and Depth Gauge to ensure you get the screw flush with the board. Firmly hold the Habito Board in place, address the screw to the face of the board, depress the drill trigger and with gentle force allow the screw to drill through the Habito board. When the screw meets the metal or timber extra force can then be applied to fix the Habito Winged screw into place.





Application

Gyproc Habito can be used to give increased rigidity and durability with improved acoustic performance. Gyproc Habito can be used as the inner or face layer in the GypWall **SUPERIOR** system, which is covered by our SpecSure® Lifetime System Warranty.

Gyproc Habito is also particularly suited for replacement of grounds in a partition, allowing for easy change of use of a building as fixtures and fittings do not require specific grounds locations*. It also removes the need for sacrificial grounds – Gyproc Habito can be used as part of the partition performance e.g. Fire & Acoustics etc. Gyproc Habito should be used as a full (face fixed) board in these cases and not cut down.

*subject to load type and maximum (pull out) loading weight

Board Range

Thickness mm	Width mm	Length mm	Edge profiles
12.5mm	1200	2400	Tapered
12.5mm	1200	2438	Tapered
12.5mm	1200	2700	Tapered
12.5mm	1200	3000	Tapered

Cutting

Gyproc Habito can be 'scored and snapped' using a sharp trade knife and then broken off. A normal trade knife with detachable blades is usually sufficient.

Fixing Habito Boards

Always fix from the bottom of the partition upwards, as is best practice.

Due to the high density and hardness of Gyproc Habito, a low stiffness stud (50 gauge) can cause stepping. In order to avoid stepping, board towards the web of the stud.



Board 1 side towards web of stud

For fixing Gyproc Habito you must use Habito Winged Screws.

Environmental Conditions

Gyproc Habito is unsuitable for use in areas subject to continuously high humidity conditions and must not be used to isolate dampness. Gyproc Habito is not suitable for use in temperatures above 49°C.

Jointing

When installing Gyproc Habito onto a metal frame tape and joint preparation is recommended and approved by Gyproc. For timber frame, and blockwork Gyproc Habito can be finished as normal with Gyproc Finishing Plasters. The Gyproc Paper Tape Joint Method (see section C08.S03.p525 of The White Book) can provide a durable joint reinforcement with a smooth, continuous, crack free surface.

Decoration

Due to its smooth, hard surface, Gyproc Habito is suitable for most types of surface coverings such as paint and wallpaper. The boards and their joints must be clean, dry and free from dust. Depending on the requirement of the decoration, ensure that all joints have been suitably sanded.

If a paint finish is desired, first apply Gyproc DryWall Primer to equalise the suction across the jointing material and the field of the board, after taping and jointing as per Gyproc guidelines. This should later be followed with two coats of good quality trade emulsion.

When using wall coverings, the application of drywall sealer to the board surface can help to prevent damage when later changing or removing the wallpaper. Heavy, semi-rigid or impermeable wall coverings may require the use of adhesives that are not compatible with Gyproc DryWall Primer or drywall sealer, please seek advice from the wallpaper and adhesive manufacturers.

Tiling

Ceramic tiles up to 12.5mm thick with a maximum weight of 32kg/m² can be applied to Gyproc Habito. Please follow manufacturer's recommendations regarding any surface preparation and adhesive that should be used. Please refer to section C08.S04.P531 of The White Book for advice on ceramic tiling onto Gyproc systems.



GypWall SUPERIOR

GypWall **SUPERIOR** is our extra strong, extra durable, sound resistant system that you can direct fix to. The system is fully compatible with all other Gyproc systems and qualifies for our SpecSure® Lifetime System Warranty.

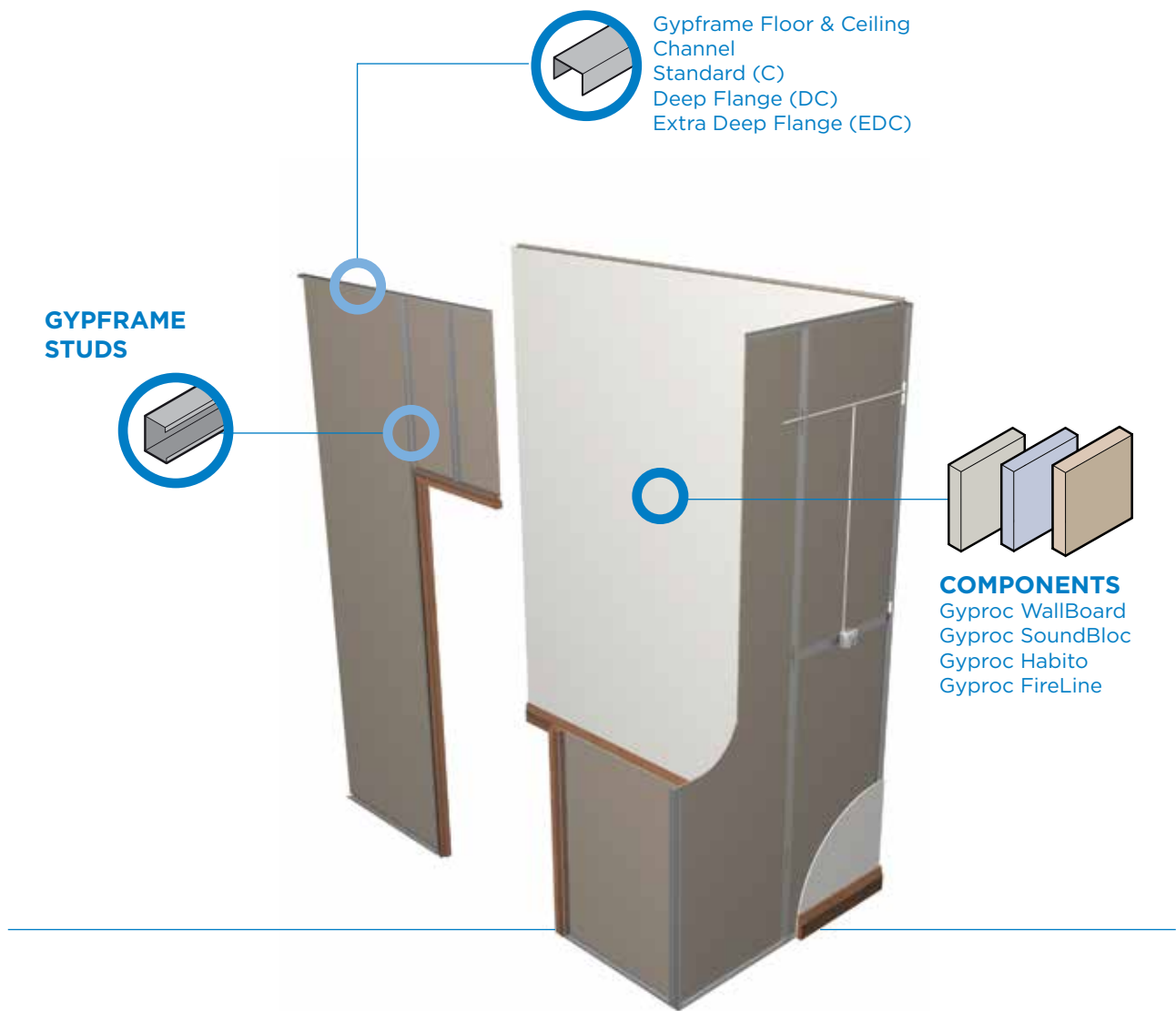

FIXING STRENGTH
Hang up to 15kg from one 5mm Woodscrew



FIRE RESISTANCE
Can achieve up to 120 minutes fire resistance.



SOUND INSULATION
The sound insulation performance of GypWall **SUPERIOR** partitions can be increased with the inclusion of Isover Acoustic Roll.



APPLICATION
A high impact-resistant partition system for use where a more durable structure is required.



Components

Type of Board	Thickness mm	Width mm
Gyproc WallBoard	12.5mm	1200
Gyproc SoundBloc	12.5mm	1200
Gyproc Habito	12.5mm	1200
Gyproc FireLine	12.5mm	1200

Gypframe Metal Sections

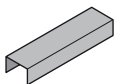

72 C 50, 72 DC 60, 72 EDC 80 Channel

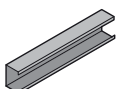

70 S 50, 70 S 60 'C' Stud

Gypframe GFS1 Fixing Strap

Gypframe 99 FC 50 Fixing Channel

Gyproc Drywall Screws

Gyproc Wafer Head Drywall Screws

Gyproc Habito Winged Screws

Gyproc Sealant – sealing airpaths for optimum sound insulation.

Isover Acoustic Roll – 25mm and 50mm

Gyproc Edge Beads – protecting and enhancing board edges.

Gyproc Control Joint – to accommodate structural movement, where required

Gyproc FireStrip – for sealing deflection heads.

Gyproc Jointing Materials

Performance

Fire resistance

The fire resistances given in Table 1 are for imperforate partitions tested to BS EN 1364-1:1999 or assessments based on these tests.

Sound Insulation

The R_w ratings given in Table 1 are for imperforate partitions and have been tested in accordance with BS EN ISO 10140-2:2010 or BS EN ISO 140-3: 1995 and rated in accordance with BS EN ISO 717-1: 1997 or assessments based on these tests.

Airtightness is essential for optimum sound insulation. While most junctions will be sealed by standard jointing materials, gaps at the base of the partition and other small airpaths can be sealed using Gyproc Sealant.

Duty Rating

The duty rating given in Table 1 has been calculated in accordance with BS 5234.

The rating is a measure of the ability of the wall to meet the requirements of four strength and robustness tests: door slam, soft body impact, hard body impact, and stiffness. Grades, e.g. Medium Duty, relate to the level of activity in adjacent areas and the degree of care likely to be exercised in them. Other optional tests may also apply.

Using the duty of a particular wall the designer can select a wall for its area of use (with due consideration for fire, sound, or thermal requirements).

GypWall SUPERIOR performance

70mm Gypframe 'C' studs

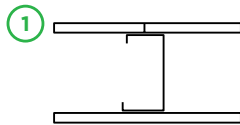

One layer of board each side of 70mm Gypframe 'C' studs at 600mm centres

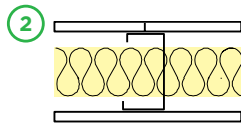

One layer of board each side of 70mm Gypframe 'C' studs at 600mm centres plus 50mm Isover Acoustic Roll in the cavity

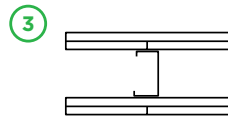

Two layers of board each side of 70mm Gypframe 'C' studs at 600mm centres

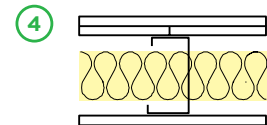

Two layers of board each side of 70mm Gypframe 'C' studs at 600mm centres plus 50mm Isover Acoustic Roll in the cavity

Detail	Board Type	Lining Thickness	Partition Thickness	Maximum partition height mm ¹	Fire Resistance ²	Lab. Sound insulation	Duty Rating	Approx. weight kg/m ²	Performance substantiation report
①	Habito	1 x 12.5mm	97	3600mm	30	38	Severe	26	K206001
②	Habito	1 x 12.5mm	97	3600mm	30	44	Severe	27	K206002
③	Habito + SoundBloc	2 x 12.5mm	122	4600mm	90	49	Severe	48	K206003
③	Habito + Habito	2 x 12.5mm	122	4600mm	120	48	Severe	50	K206004
④	Habito + SoundBloc	2 x 12.5mm	122	4600mm	90	55	Severe	49	K206005
④	Habito + FireLine	2 x 12.5mm	122	4600mm	120	52	Severe	49	K206006
④	Habito + Habito	2 x 12.5mm	122	4600mm	120	53	Severe	51	K206007

¹ Based on a limiting deflection of L/240 at 200Pa . If greater heights are required, please refer to the section. Where special design requirements, please consult the Gyproc Technical Department for guidance.

² Board joints must be reinforced with Gyproc Paper Joint Tape for the quoted fire resistance periods to be achieved.



Design

Planning – key factors

The position of some services and heavy fixtures should be predetermined, and their installation planned into the frame erection stage. All penetrations will need to be adequately fire-stopped if integrity is to be maintained.

Electrical

The installation of electrical services should be carried out in accordance with all relevant legislation, regulations and guidance. The cut-outs in the studs can be used for routing electrical and other small services.

Service penetrations

Penetrations of fire resistant constructions for services need careful consideration to ensure that the integrity of the element is not impaired, and also that the services themselves do not act as a mechanism of fire spread.

It is important to use only those services and their installations which have been shown by fire test to be able to maintain the integrity of the construction.

Wind loading

GypWall partitions are non-loadbearing but can accept a degree of wind loading, for example when used in buildings with large or multiple external doors. The maximum recommended heights in Table 1 are based on a limiting deflection of $L/240$ at a pressure of 200Pa.

Solutions may be provided for specific requirements to achieve greater pressures and limiting deflection characteristics. “Note maximum recommended heights may be affected”. Please contact the Gyproc Technical Department for further information.



Deflection heads

Deflection heads, by definition, must be able to move and, therefore, achieving an airtight seal is difficult. Inevitably, this will have a detrimental effect on the acoustic performance of any wall which incorporates deflection at the head. The approach shown in section C04 – GypWall **STAGGERED**, of the current Gyproc White Book, could be considered to minimise loss of performance. In most cases, a suspended ceiling will also assist in minimising loss of performance.

Fixing floor and ceiling channels

Floor and ceiling channels must be securely fixed with a row of fixings at 600mm maximum centres (148mm channels require two rows of staggered fittings at 600mm centres in each row). If the floor is uneven, a 38mm thick timber sole plate equal to the width of the channel should be used.

If the concrete or screeded floor is new, consideration should be given to the installation of a damp proof membrane between the floor surface and the channel or sole plate.

Door openings

The designer should consider the thickness tolerances of the partition types in relation to the proposed door frame detail. To satisfy BS5234 requirements for heavy and severe duty, door framing should be specified in accordance with Figure 5 or 6 (on the following pages).

Exceptionally heavy doorsets may require additional provision. Contact the Gyproc Technical Department if further guidance is required.

Control joints

Control joints may be required in the partition to relieve stresses induced by expansion and contraction of the structure. The location of control joints is at the discretion of the specifier. It is recommended that they coincide with movement joints within the surrounding structure.

Fixtures

Due to the inherent strength of Gyproc Habito, some fixtures can be applied directly to the board. Please see Page 4 of this Data Sheet for more information.

1

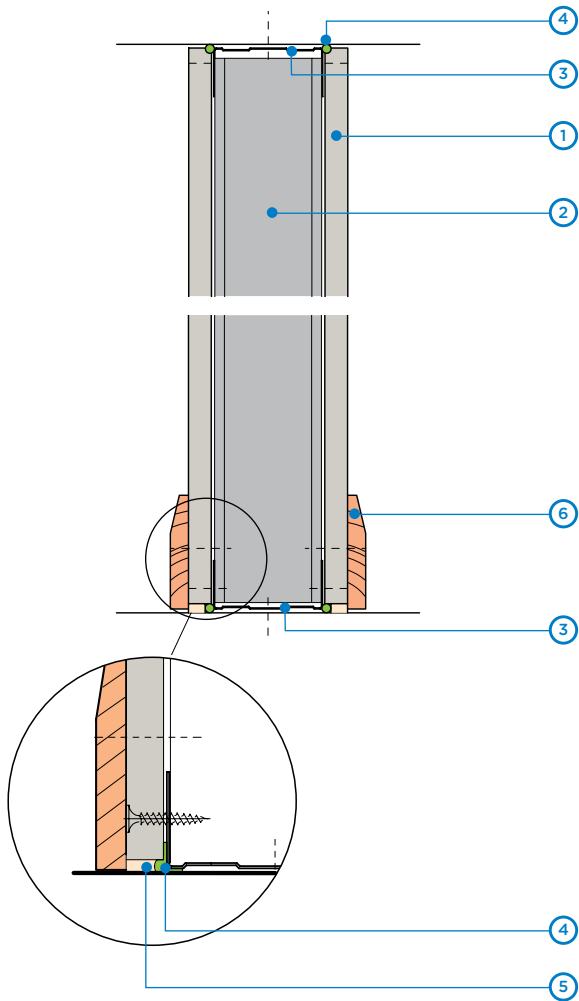

Head and base

2

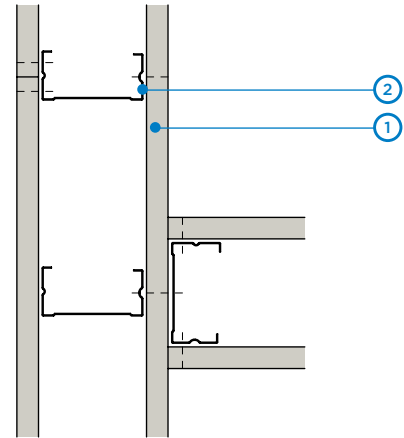

'T' junction - single layer

3

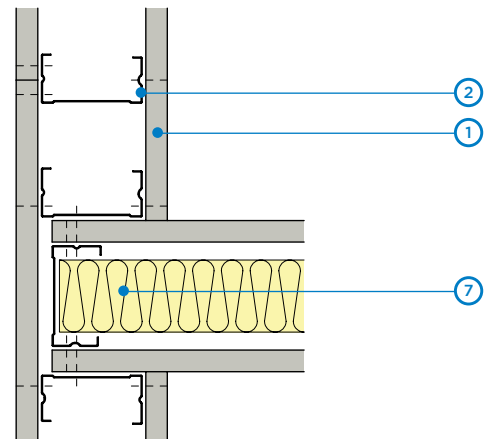

'T' Junction when partition with higher acoustic performance abuts a partition with lower acoustic performance. Acoustic principles only - detail may not be suitable for all solutions.

- 1 Gyproc plasterboard
- 2 Gypframe 'C' Stud
- 3 Gypframe Floor & Ceiling Channel
- 4 Gyproc Sealant
- 5 Bulk fill Gyproc jointing materials (where gap exceeds 5mm)
- 6 Skirting

- 7 Isover Insulation

GypWall SUPERIOR construction details (continued)

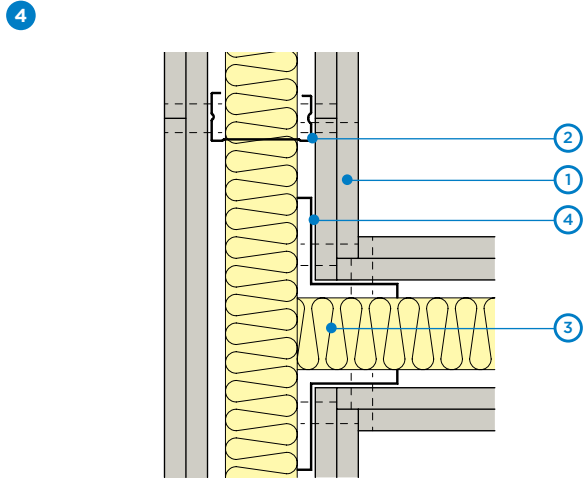

'T' junction to optimise acoustic performance and reduce flanking transmission

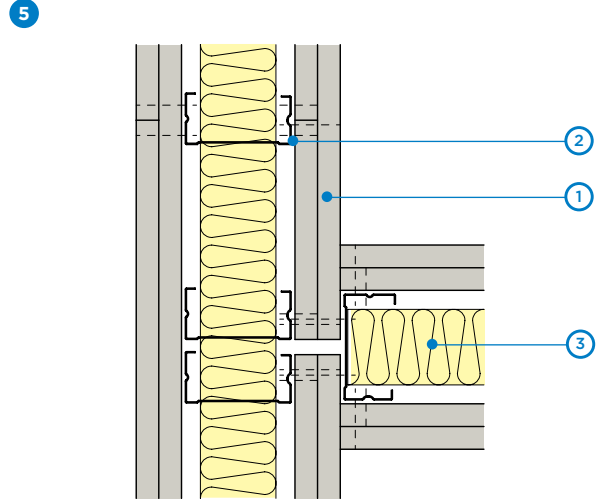

'T' junction to optimise acoustic performance and reduce flanking transmission

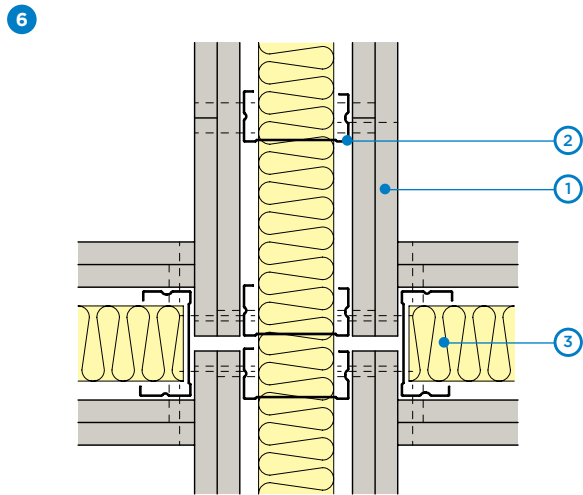

Four way junction to optimise acoustic performance and reduce flanking transmission

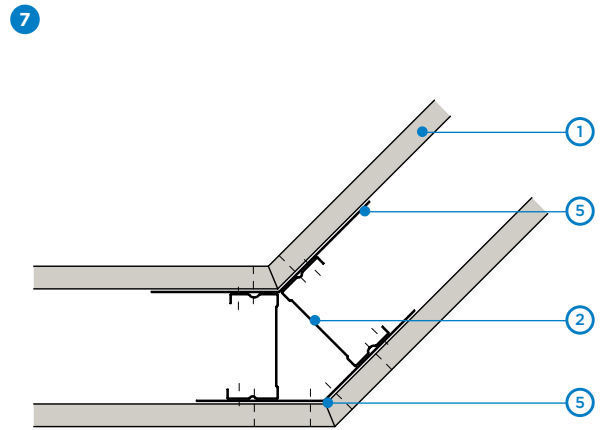

Splayed corner

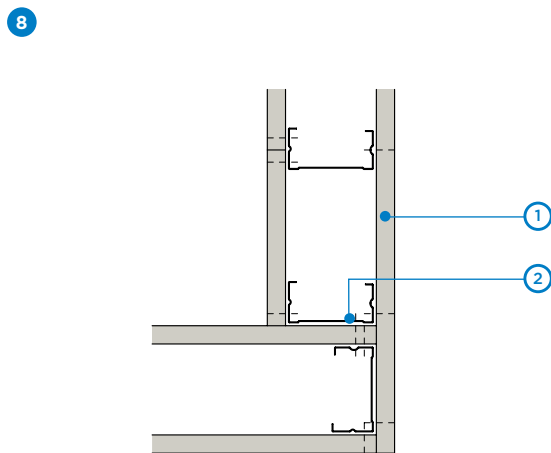

Corner detail - single layer

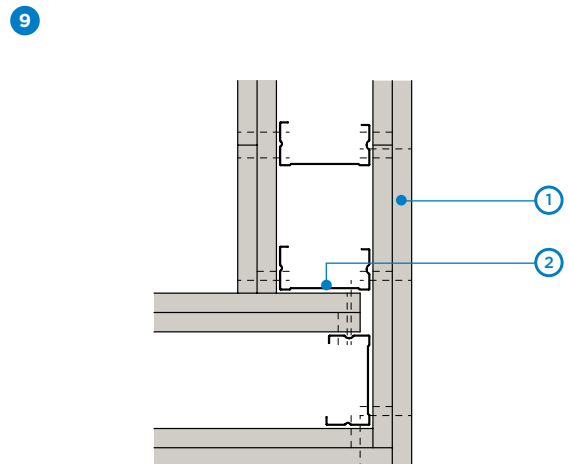

Corner detail - double layer

- 1 Gyproc plasterboard
- 2 Gypframe 'C' Stud
- 3 Isover insulation

- 4 Gypframe GA5 Internal Fixing Angle
- 5 Gypframe GA6 Splayed Angle

10

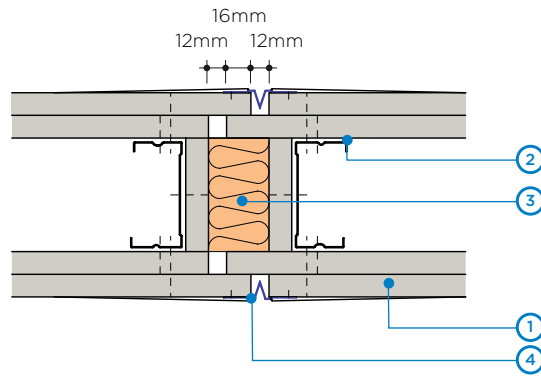

11

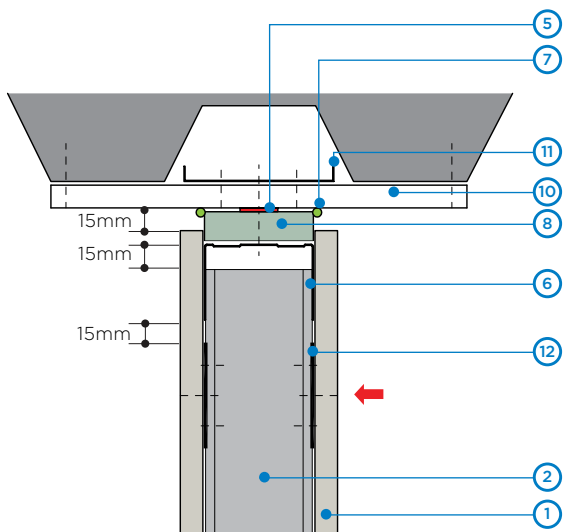

Deflection head parallel to floor profile for 15mm downward movement and up to 60 minutes fire resistance¹

12

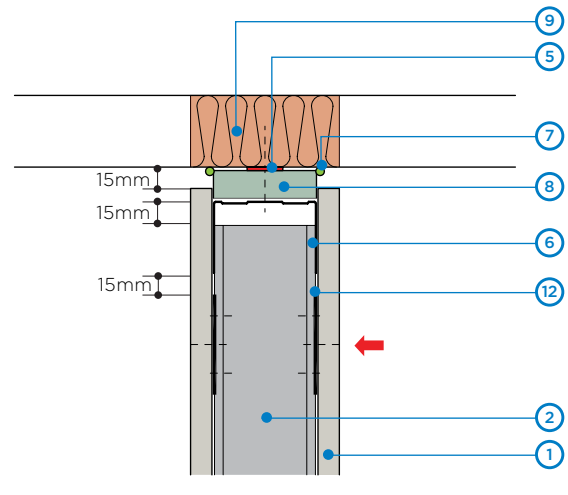

Deflection head perpendicular to floor profile for 15mm downward movement and up to 60 minutes fire resistance

- 1 Gyproc plasterboard
- 2 Gypframe 'C' Stud
- 3 Stone mineral wool (minimum density 23kg/m³) (by others)
- 4 Gyproc Control Joint
- 5 Gyproc FireStrip (continuous line)
- 6 Gypframe Deep Flange Floor & Ceiling Channels (DC)
- 7 Gyproc Sealant

- 8 Gyproc CoreBoard
- 9 Fire-stopping (by others)
- 10 Glasroc F FIRECASE
- 11 Gypframe 99 FC 50 Fixing Channel
- 12 Gypframe GFS1 Fixing Strap fixed to studs with Gyproc Wafer Head Drywall Screws

NB Installing the screw into the side of the Gypframe Service Support Plate and the web of the Gypframe 'C' Stud will avoid creating excessive distortion to the lining board. No fixings should be made through the boards into the flanges of the head channel. The arrow (←) denotes the position of the uppermost board fixing, which should be made into Gypframe GFS1 Fixing Strap. Continuous Gyproc FireStrip must be installed as shown to maintain fire performance.

¹ To minimise acoustic downgrade, install Isover insulation within the hollow rib void.

GypWall SUPERIOR construction details (continued)

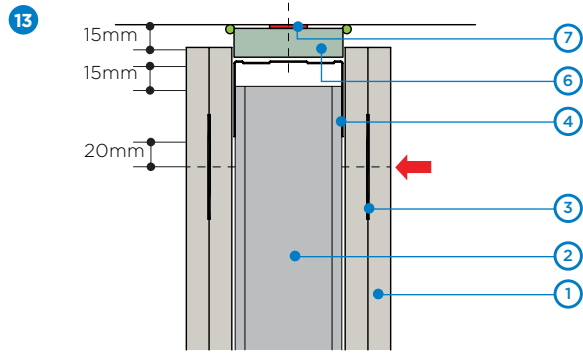

Deflection head for 15mm downward movement and 60 minutes fire resistance

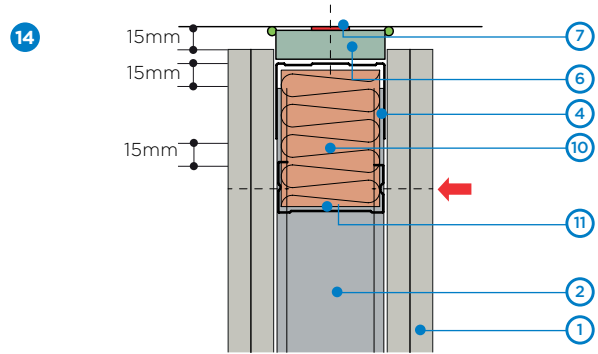

Deflection head for 15mm downward movement and up to 120 minutes fire resistance

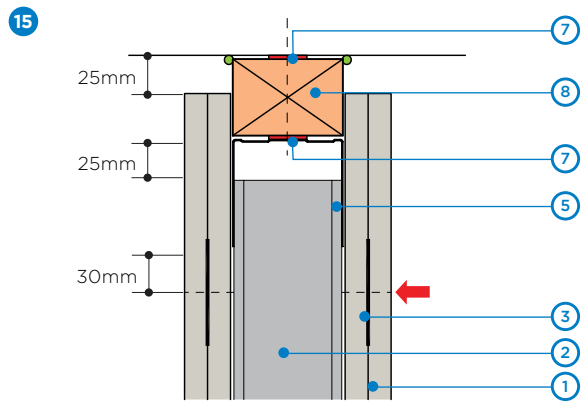

Deflection head for plus or minus 25mm movement and 60 minutes fire resistance

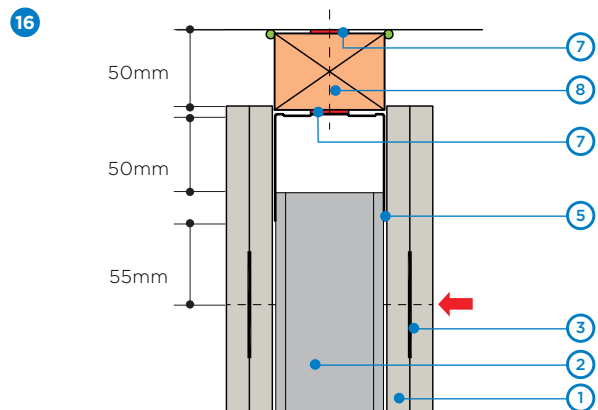

Deflection head for 50mm downward movement and 60 minutes fire resistance

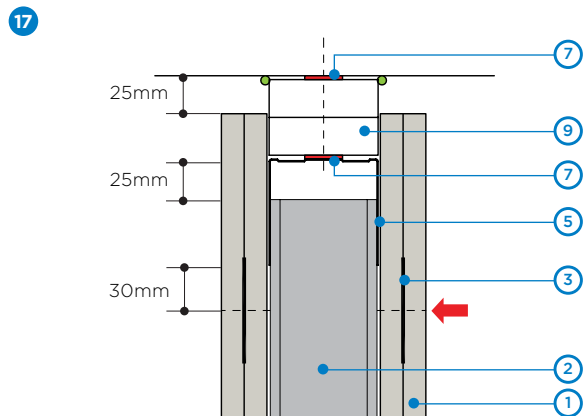

Deflection head for plus or minus 25mm movement and 60 minutes fire resistance

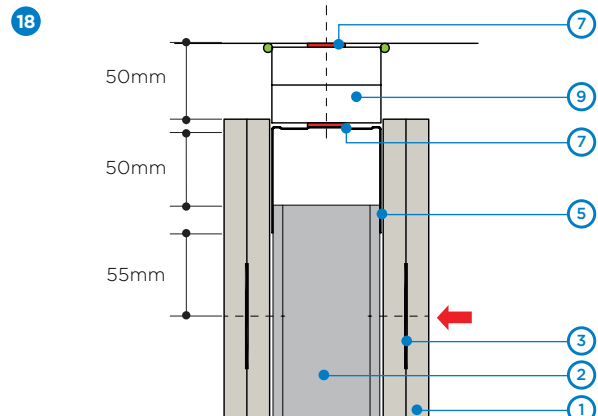

Deflection head for 50mm downward movement and 60 minutes fire resistance

1 Gyproc plasterboard

2 Gypframe 'C' Stud

3 Gypframe GFS1 Fixing Strap

4 Gypframe Deep Flange Floor & Ceiling Channel

5 Gypframe Extra Deep Flange Floor & Ceiling Channel

6 Gyproc CoreBoard

7 Gyproc FireStrip (continuous)

8 Timber head plate suitably fixed to structure

9 25mm Glasroc F FIRECASE

10 Stone mineral wool (by others)

11 Nogging cut from Gypframe 'C' Stud

NB No fixings should be made through the boards into the flanges of the head channel. The arrow (➡) denotes the position of the uppermost board fixing, which should be made into Gypframe GFS1 Fixing Strap (or stud nogging in construction detail 14). continuous Gyproc FireStrip must be installed as shown to maintain fire performance. Where there is a need for a deflection head in a 90 minute wall, the 120 minute solution can be used (refer to construction detail 16) or alternatively, please contact the Gyproc Technical Department for further guidance.

19

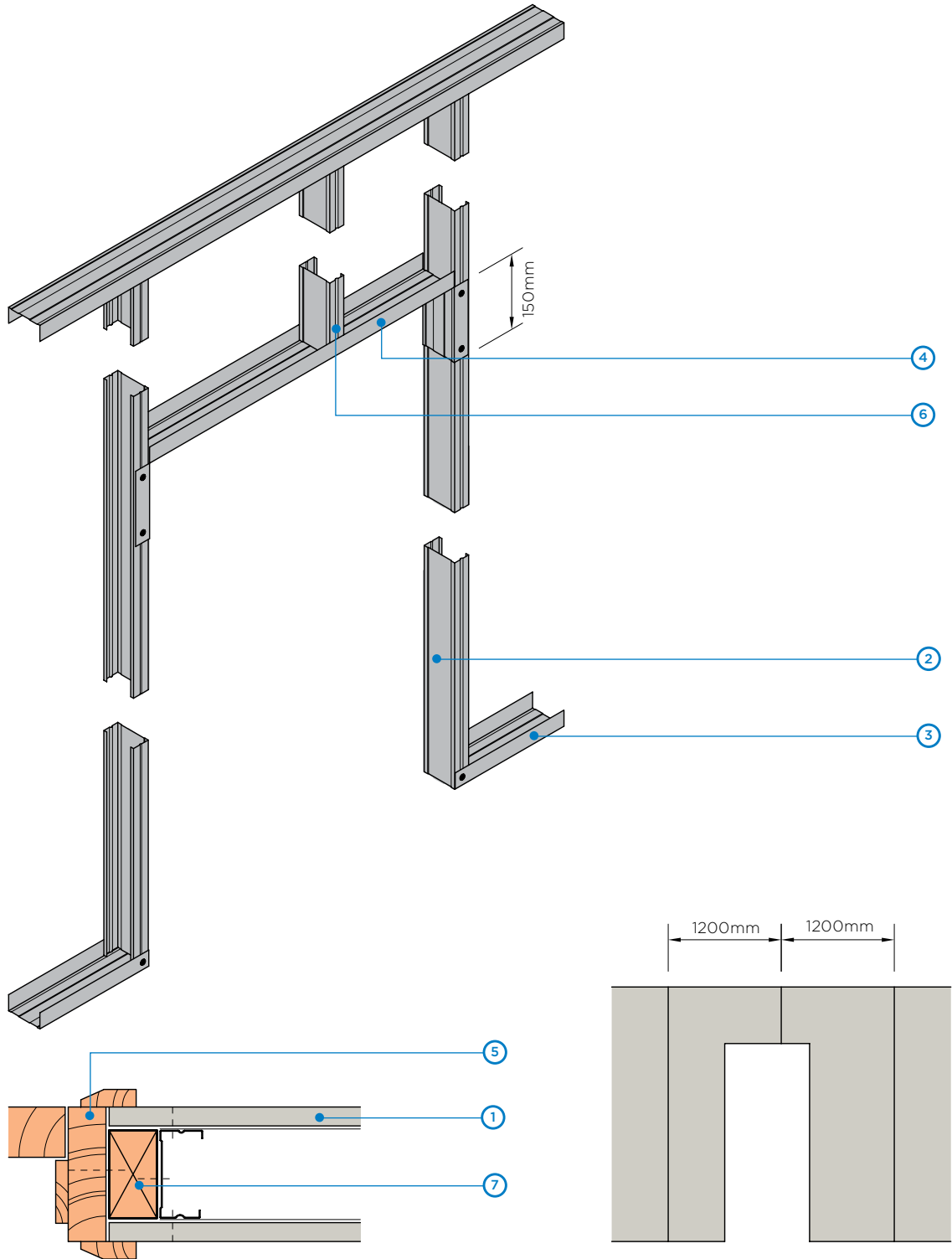

Door frame (maximum 1200mm width) to satisfy BS 5234: Parts 1 & 2: 1992 - Light and Medium Duty (up to 35kg door)

- | | |
|---|---|
| <ul style="list-style-type: none"> 1 Gyproc plasterboard 2 Gypframe 'C' Stud 3 Gypframe Floor & Ceiling Channel 4 Gypframe Floor & Ceiling Channel cut and bent to form door head | <ul style="list-style-type: none"> 5 Timber door frame and architrave 6 Gypframe 'C' Stud to maintain stud module 7 Timber sub-frame |
|---|---|

NB Advice should be sought from the door manufacturer prior to the construction of these details.

20

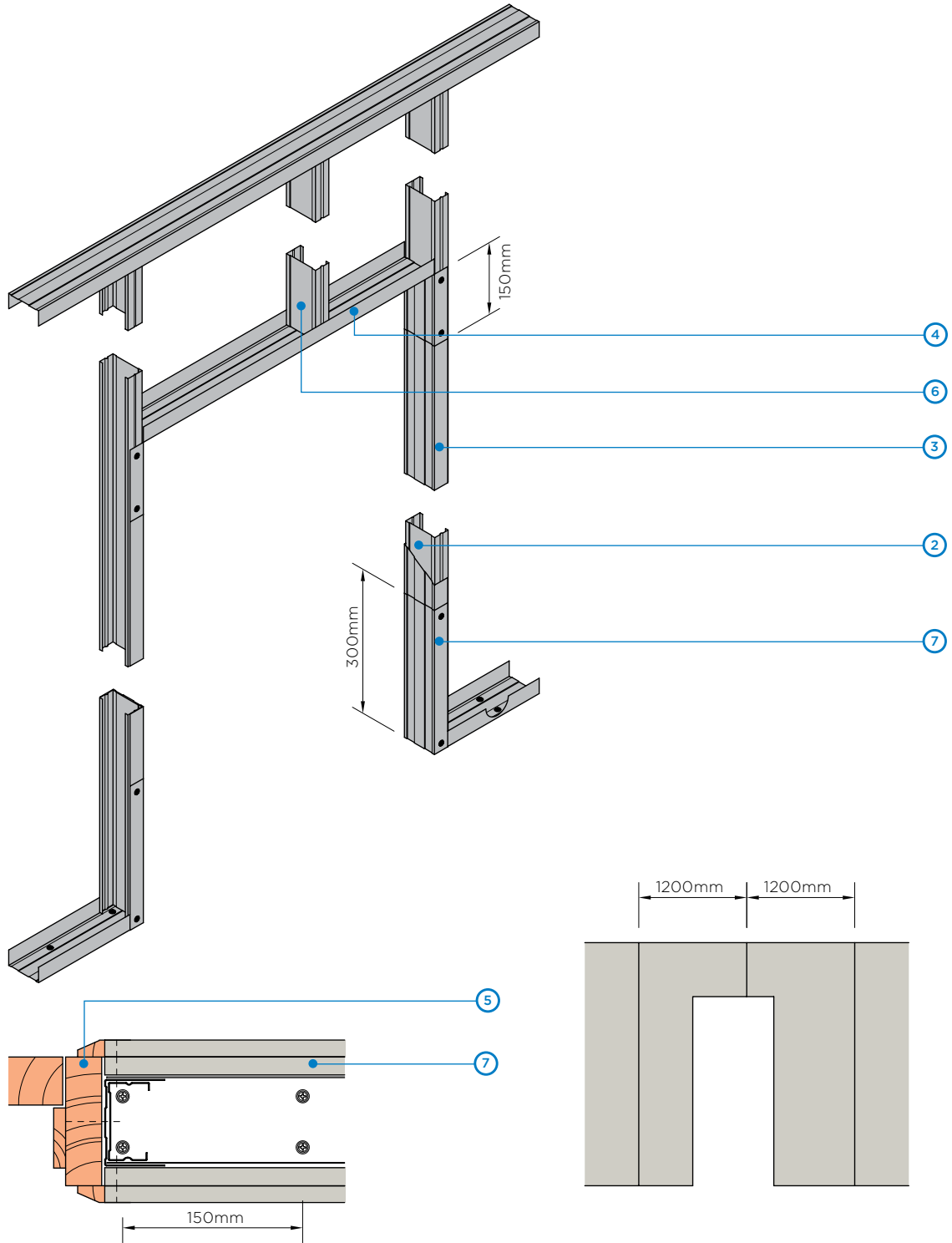

Door frame (maximum 1200mm width) to satisfy BS 5234: Parts 1 & 2: 1992 – Heavy and Severe Duty (up to 60kg door)

- | | |
|---|---|
| <ul style="list-style-type: none"> 1 Gyproc plasterboard 2 Gypframe 'C' Stud 3 Gypframe Floor & Ceiling Channel to sleeve studs 4 Gypframe Floor & Ceiling Channel cut and bent to form door head | <ul style="list-style-type: none"> 5 Timber door frame and architrave 6 Gypframe 'C' Stud to maintain stud module 7 Gypframe Floor & Ceiling Channel cut and bent to extend up studs |
|---|---|

NB Advice should be sought from the door manufacturer prior to the construction of these details.

NB At the base, the channel is cut and bent to extend 300mm up the studs and fixed each side with two Gyproc Wafer Head Drywall Screws. The studs each side of the opening are sleeved full height of opening with Gypframe Floor & Ceiling Channel.

21

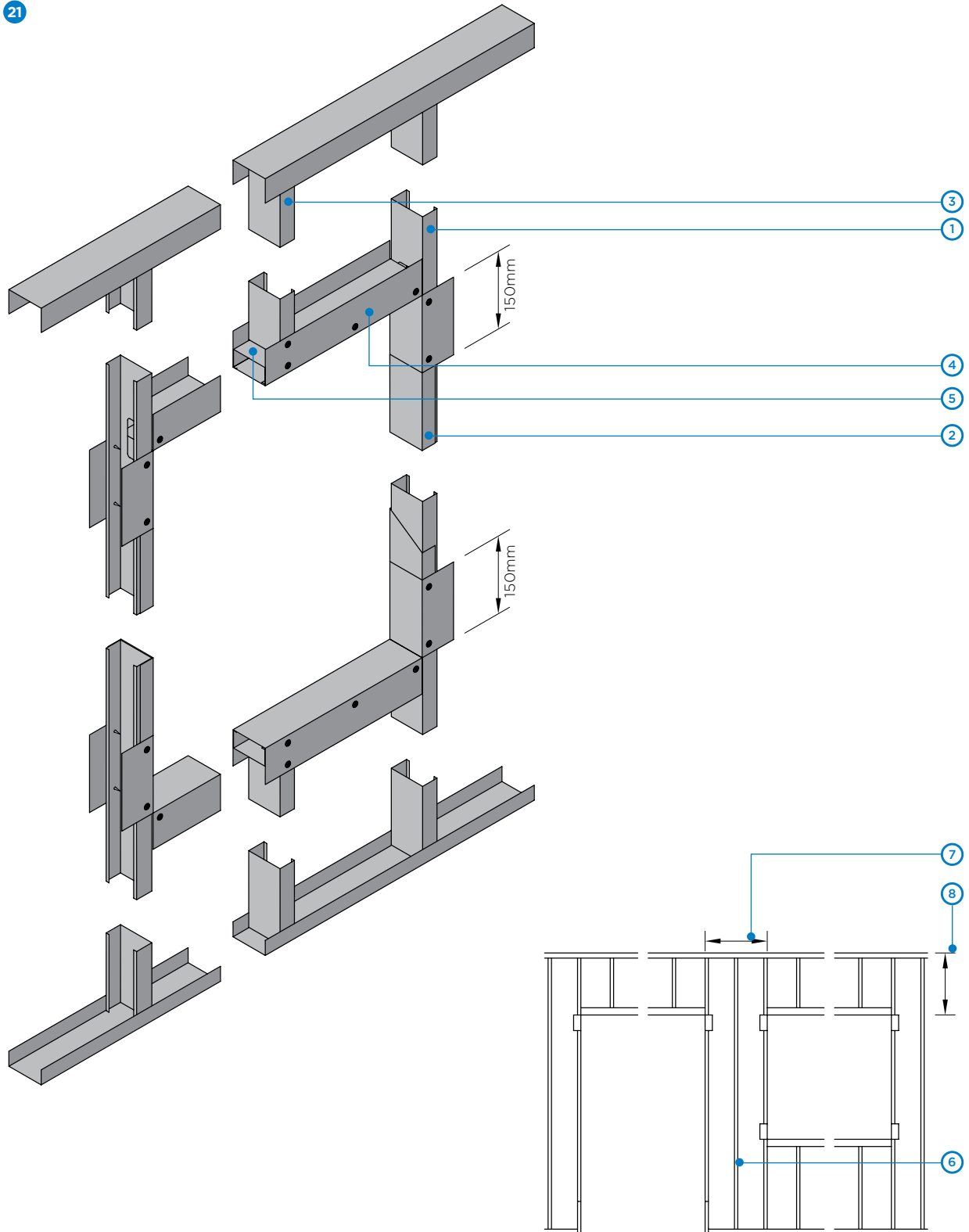

Openings 1201 – 3300mm wide, for example double doors or large windows

- | | |
|--|--|
| <ul style="list-style-type: none"> 1 Gypframe 'C' Stud 2 Stud sleeved to full opening height with Gypframe Floor & Ceiling Channel 3 Gypframe studs (appropriate to system) 4 Gypframe Extra Deep Flange Floor & Ceiling Channel 5 Gypframe stud insert | <ul style="list-style-type: none"> 6 Centre stud required for margin up to 600mm between openings 7 Partition between openings, minimum 600mm for Gypframe 'C' Studs (minimum 300mm for Gypframe 'I' Studs) 8 Maximum distance 2400mm (if exceeds 2400mm contact Gyproc Technical Department) |
|--|--|

22

Elevation

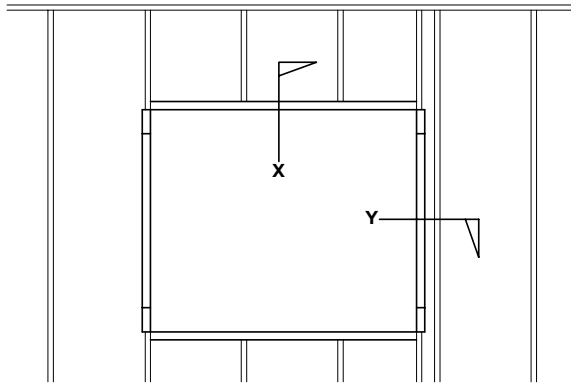

Section X - X

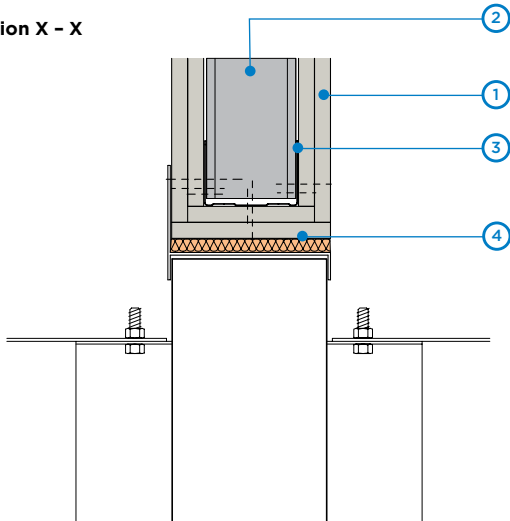

Section Y - Y

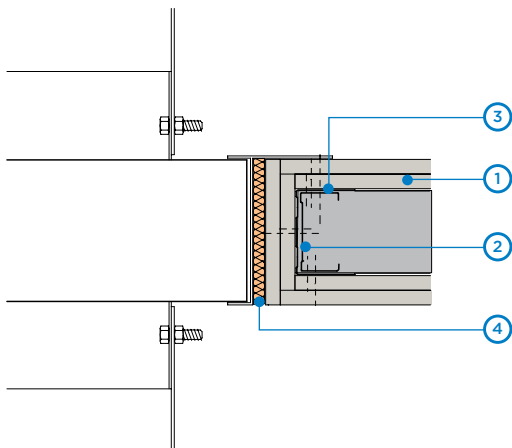

Opening for service penetrations in fire-rated partitions

23

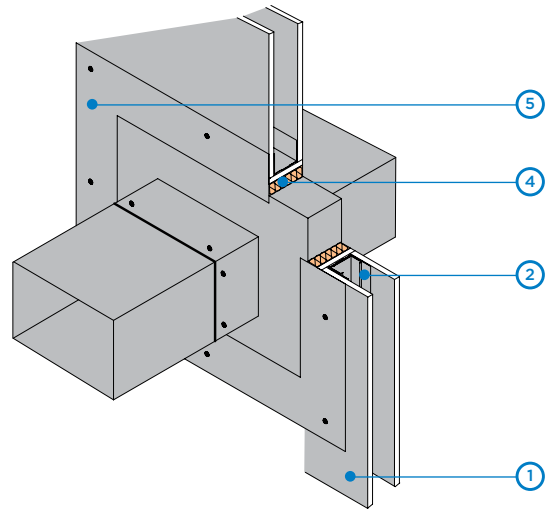

Fire tested construction in which the damper is supported by the partition (isometric view)

24

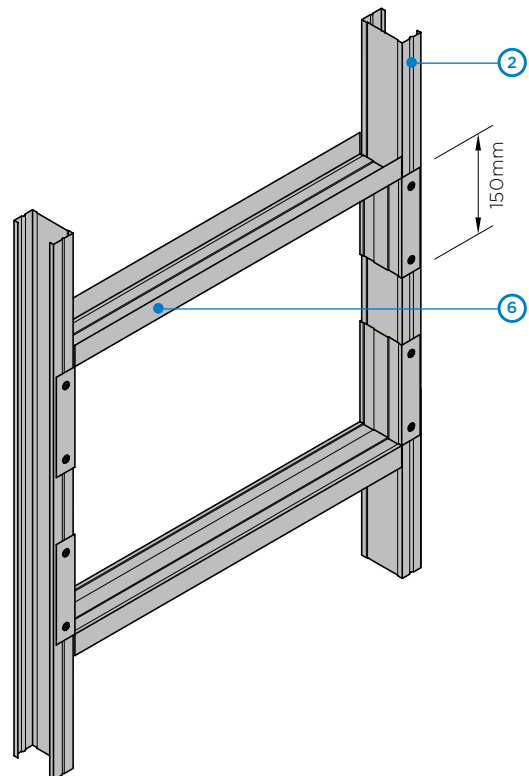

Opening up to 600mm wide for services

- 1 Gyproc plasterboard
- 2 Gyproframe 'C' Stud
- 3 Gyproframe Floor & Ceiling Channel
- 4 Penetration seal if required (refer to damper manufacturer for details)

- 5 Damper (by others). Weight of damper should not exceed 57kg. Size of damper should not exceed 1400 x 1200mm
- 6 Gyproframe Folded Edge Standard Floor & Ceiling Channel cut and bent to form opening head and cill

25

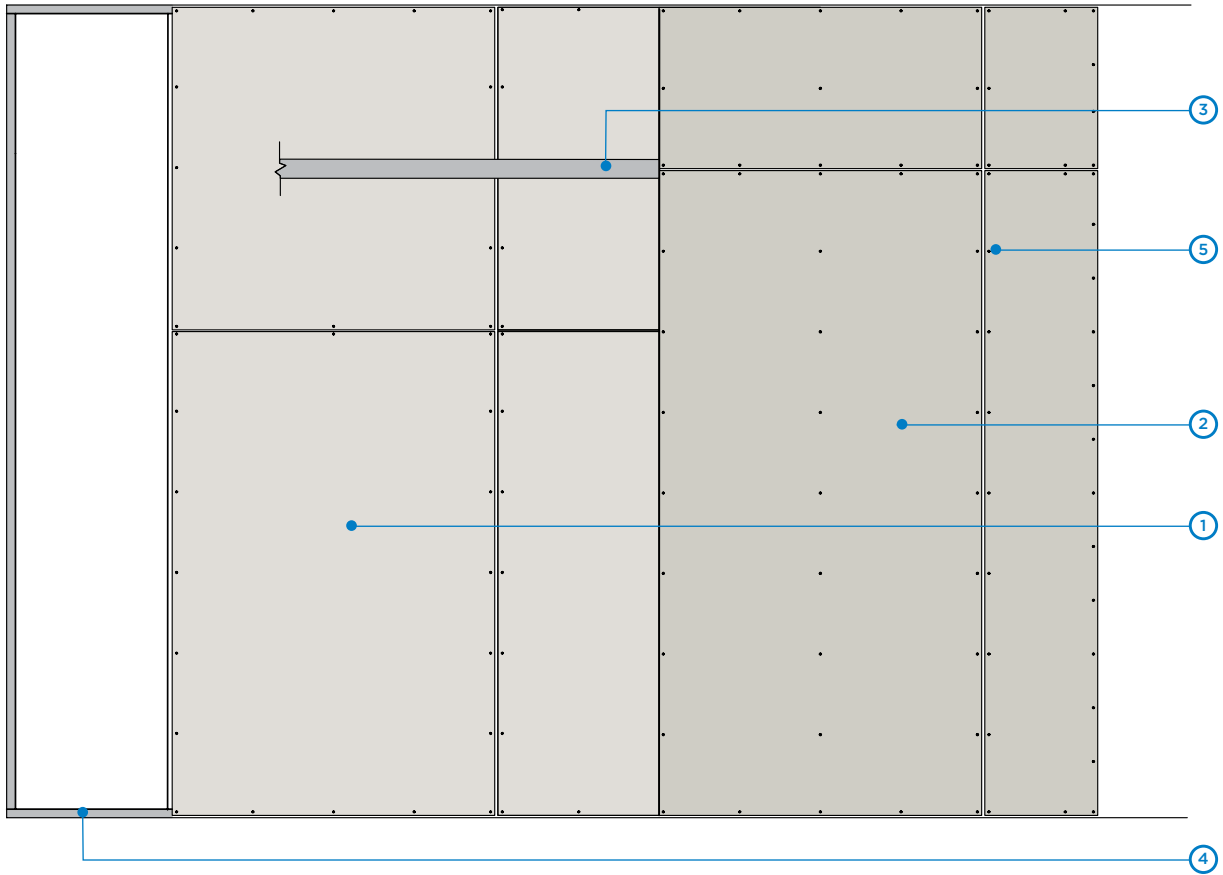

Board layout - typical configuration

26

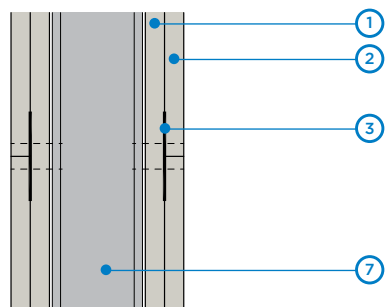

Horizontal board joint - double layer

27

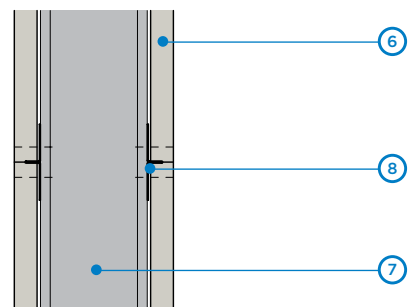

Horizontal board joint - single layer

- 1 Inner layer of Gyproc plasterboard
- 2 Outer layer of Gyproc plasterboard
- 3 Gypframe GFS1 Fixing Strap
- 4 Gypframe metal framing

- 5 Gyproc Drywall Screws or Habito Winged Screws
- 6 Gyproc plasterboard
- 7 Gypframe 'C' Stud
- 8 Gypframe GFT1 Fixing T (alternatively use Gypframe GSF1 Fixing Strap)

Notes



Gyproc

Unit 4,
Kilcarbery Business Park,
Nangor Road,
Dublin 22
D22 R2Y7

Telephone: +353 (0)1 6298400
Email: enquiries@gyproc.ie

www.gyproc.ie



Technical Support

ROI: Free Phone: 1800 744480
NI: Free Phone: 0845 3990159
Email: tech.ie@saint-gobain.com

