



# The White Book

# Contents

## C01 Introduction

## C02 Technical performance

Introduction	C02.S01.P15
Fire	C02.S01.P16
Building acoustics	C02.S01.P21
Robustness	C02.S01.P37
Service installations	C02.S01.P41
Thermal insulation and condensation	C02.S01.P49
Sustainability	C02.S01.P57

## C03 Steel encasements

Introduction	C03.S01.P65
FireCase	C03.S02.P70
Gyplyner ENCASE	C03.S03.P90

## C04 Partitions

Introduction	C04.S01.P105
GypWall	C04.S02.P124
GypWall ROBUST	C04.S03.P156
GypWall EXTREME	C04.S04.P178
GypWall QUIET SF	C04.S05.P192
GypWall STAGGERED	C04.S06.P206
GypWall QUIET	C04.S07.P218
GypWall QUIET IWL	C04.S08.P230
GypWall AUDIO	C04.S09.P244
GypWall SUPERIOR	C04.S10.P258
Non-loadbearing timber stud	C04.S11.P274

## C05 Specialist partitions

Introduction	C05.S01.P287
ShaftWall	C05.S02.P290
FireWall	C05.S03.P320
GypWall CURVE	C05.S04.P328
GypWall SECURE	C05.S05.P338
BlastWall	C05.S06.P343

## **C06 Floors and ceilings**

Introduction	C06.S01.P345
CasoLine MF	C06.S02.P354
Gyplyner	C06.S03.P376
GypFloor SILENT	C06.S04.P390
Loadbearing timber joist floors	C06.S05.P402
Cavity fire barriers	C06.S06.P422

## **C07 Linings**

Introduction	C07.S01.P429
Plaster systems	C07.S02.P434
Drilyner Wall Linings	C07.S03.P444
Gyplyner	C07.S04.P460
Gyplyner iwl	C07.S05.P468

## **C08 Finishes**

Introduction	C08.S01.P483
Plaster skimming	C08.S02.P486
Jointing	C08.S03.P492
Tiling	C08.S04.P498
Decorative effects	C08.S05.P506

## **C09 Glossary and index**

Glossary	C09.S01.P512
Index	C09.S02.P516

## **Updates and Revisions**

Loadbearing Timber Joist Floors Performance – *Updated April 2025*

Casoline MF Ceilings – *Updated April 2025*

GypLyner IWL – *Updated April 2025*

Horizontal ShaftWall – *Updated April 2025*

Timber Joist Floors – *Updated April 2025*

Deflection Head Updates – *Updated April 2025*

Fire Testing Reference Updates – *Updated April 2025*

Non-Loadbearing Timber Stud – *Updated October 2025*

Gypwall QUIET – *Updated October 2025*

FireWall – *Updated October 2025 (img)*

Jointing – *Updated October 2025*

Duraline and Steel Encasements – *Updated March 2026*

# CO1

## Introduction



 **gyproc**  
SAINT-GOBAIN

## Introduction

Gyproc



We develop and provide effective solutions that meet the ever-changing needs of the industry, whilst providing benefits for both the construction industry and the end user. We are constantly looking at future needs and are already developing a new generation of products and systems that will help you in the way you create spaces.

We care passionately about our products and systems. We also care about the people who specify, install and live with them, and we go out of our way to develop new ideas that will improve specifier, installer and end user experiences, working with them throughout the development cycle.

For over a century, we've led the market in high-performance internal partitioning systems - providing plaster, plasterboard, drylining and ceiling solutions which have shaped modern interiors, a fact of which we are very proud.

### Innovation throughout our business

Our approach to innovation is built on the premise that our products must provide meaningful benefits to customers, from the installer through to the end user. We use a test, learn and iterate approach, which underpins our whole process. We therefore have a dedicated insight and innovation team who immerse themselves in the lives of our customers. This brings an understanding of the issues customers face and how our new product development and system improvements can deliver real solutions.

We have numerous systems and products in development at any one time. To find out more about those we have recently launched, please visit the Gyproc website: [gyproc.ie](http://gyproc.ie)



### Additional information

The only gypsum manufacturer in Ireland, Gyproc has two local Technical Academies but also international research, development and testing facilities that rank amongst the best in Europe, a technical support infrastructure that leads the industry and a network of over 400 stockists to ensure national product availability. What's more we are part of Saint-Gobain, a global operation serving customers in more than 50 countries.

## Introduction

### Our offer to you

When you work with Gyproc you get a commitment to superior quality and service. As a specifier or installer of our systems, we will support you with technical advice, to help guide you to the best solution for your design. We also offer training and up-skilling to ensure our systems can be installed and inspected to meet your performance requirements. Whatever your business needs, we're sure we have a service to support you.



#### Gyproc Technical Department

Whatever technical enquiry you have, we're here to ensure you receive the best possible advice.

All of our advisors are fully trained on legislation, system and product performance, and can help you with your questions, whether small or complex. You can obtain advice on a range of topics, i.e. acoustic, fire, structural, thermal, moisture and sustainability requirements. Through this combination of specialist knowledge, the understanding of the principles of construction and the interfaces within a construction project, our technical specialists can offer guidance on Gyproc products and systems, providing solutions to meet all of your specification needs.

We continuously monitor our calls and survey our customers to ensure that our service offering meets the high standards of customer satisfaction you expect from our Gyproc Technical Department.

If you have any technical enquiries we are open Weekdays from 09:00 to 17:30, closing at 17:00 on Fridays. You can contact our team via the telephone or by email below:

Tel: ROI: 1800 744480 NI: 0845 3990159

Email: [tech.ie@saint-gobain.com](mailto:tech.ie@saint-gobain.com)



#### Handy hint

For our System Selector go online at [gyproc.ie](http://gyproc.ie)



#### Important information

Whether yours is one of the thousands of enquiries a month to our technical advice line, or you need on-site support or full off-site training, we will support you all the way.

# Introduction

Our offer to you (continued)



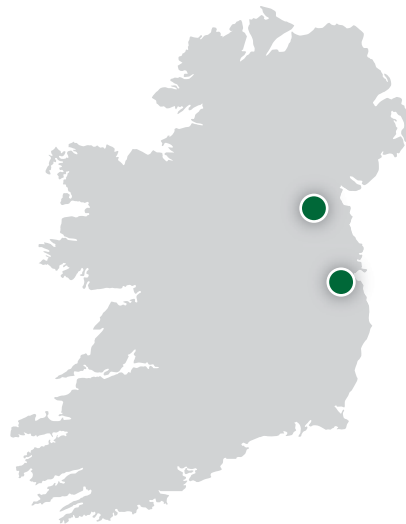
## Saint-Gobain Technical Academies

Since 2010 we've helped thousands of new and existing customers to develop their practical skills as well as knowledge of product specification, best practice, technical and regulatory requirements. This ensures the quality of your specification, and our products and systems, when installed on site.

The Saint-Gobain Technical Academies provide the most comprehensive training support package in the industry. Our specialist teams of technical experts and training personnel will provide all the support you need including training on and assisting site installation and beyond.

Saint-Gobain has been pioneering training for 50 years, equipping customers and our own employees with the latest industry knowledge and skills. We have invested in opening two local training academies, making our industry recognised training easy and accessible to everyone.

With CPD accreditation and CIRI and Qualibuild recognition, we help to train over 1,000 professionals each year aiding them to gain specialist knowledge in all aspects of plastering, drylining and sustainable building.



If you'd like to see how we can help you further or just find out more detailed information about Gyproc training courses please go to [www.saint-gobain.ie/technical-academy](http://www.saint-gobain.ie/technical-academy) and register with us today.  
Tel: ROI: 1800 744480 NI: 0845 3990159

## Introduction

### The highest quality components

We know how important it is that the systems you choose provide the best possible solution for the space you wish to create. This is the reason why our solutions are driven by your requirements, involving customers throughout the development process, so that when we launch a new solution we know it meets your needs.

#### Gyproc systems



Our systems comprise only of the highest quality components, designed to work together to deliver the level of performance required. They have been tested to meet our rigorous performance and quality standards, ensuring peace of mind.

#### Gyproc plaster products



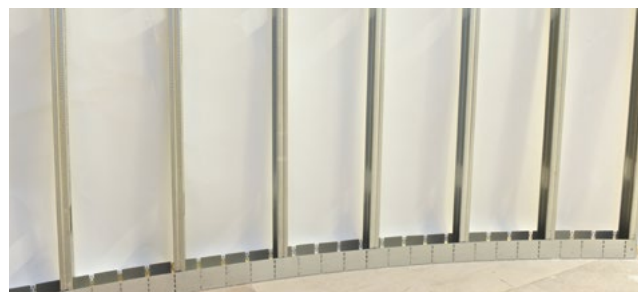
Our world leading range of Gyproc undercoat and finish plasters are unmatched for quality, consistency, workability and on-the-wall performance. Backed up by a range of compatible high-quality accessories, Gyproc plasters produce a high-quality surface that's tough and durable. Gyproc plasters meet all customer demands for an aesthetic, low maintenance internal surface finish for a range of standard and specialist applications.

#### Gyproc plasterboard products



Our Gyproc plasterboard products have been developed over more than 80 years, providing proven lining solutions that help Gyproc systems meet the fire, thermal, acoustic, moisture, impact, sustainability and lifetime performance demands of any building. It is the widest range of high quality plasterboards on the market for walls, ceilings, floors, partitions and encasements. As an additional service, for major projects, Gyproc plasterboards can be supplied in bespoke lengths to support increased installation speed and reduced carbon footprint and waste on site.

#### Gypframe metal products



Gypframe metal products provide the backbone for all Gyproc systems and are the modern, engineered alternative to traditional timber and masonry construction, meeting the highest performance requirements. The range of metal studs, channels, angles, brackets and associated components is the widest and highest range of quality metals system components in the industry. It is also designed using the unique UltraSTEEL® process, which gives the components greater strength, makes fixing easier and improves screw retention and pull-out by up to 20%. In essence when you specify our full systems with Gypframe metal components, we will guarantee them for a lifetime.

▶ Refer to *SpecSure*® on C01. S01. P08 for further information.

## Introduction

The highest quality components (continued)

### Specialist plasterboards



Our specialist boards are designed to offer outstanding performance in key areas such as fire performance and resistance against water and impact. These boards can be used for high performance applications in commercial, industrial and residential buildings, as well as within the off-site sector.

Glasroc F specialist boards provide the basis for specialised fire resistance and steel protection systems for a range of buildings.

Rigidur has high impact resistance and superior fixing strength and is also available in large formats for off-site manufacturers.

The latest addition to the Gyproc specialist board range, Gyproc Habito provides enhanced acoustics, impact resistance and for the first time, fixing capability.

### Ceiling products



The ceiling areas are normally the largest expanse available to be able to create an impact within a space. The Gyproc acoustic ceiling range combines exciting aesthetic design with excellent performance. Our tiles, planks and boards, combined with our suspended metal framing systems, bring design back to performance ceilings. Building on gypsum's unique fire characteristics we can offer you systems with enhanced acoustic, moisture and impact resistant performance for the most demanding ceiling projects - providing unique solutions for buildings, from schools to offices, from healthcare to high-rise multi-occupancy and retail to residential developments.

### Testing

Gyproc pioneered the introduction of lightweight, fast track building solutions in Ireland. It has had a huge impact on the residential and commercial built environment. Through extensive test programmes and on-site system development we have been able to create solutions that exceeds even the most rigorous National and European test standards.

### Laboratory testing



Gyproc systems are tested at the Building Test Centre. This UKAS accredited testing laboratory offers the best equipped and most advanced testing facilities in Europe. Here more than 10,000 tests and substantiation reports underpin the performance of drylining products and systems across the industry and are the basis of our SpecSure® guarantee.

The Building Test Centre houses comprehensive fire, acoustic and structural test facilities, and have been developed specifically for testing partitions, ceilings and other drywall structures to National, European and international test standards.

In addition to the quality of the testing facilities, many features of the laboratories, such as the six metre fire test furnace, full BS 5234 duty testing suite are unique. It ensures that Gyproc systems are the most comprehensively and accurately tested systems on the market.

### Site testing

As well as comprehensive laboratory testing, we need to be sure that our systems not only perform to standards on site, but meet the installers' needs for speed and simplicity of installation.

Testing and proving on-site is therefore an integral part of the development process for every new Gyproc system or system enhancement. A close working partnership with the Ireland's leading drywall and plastering contractors, housebuilders and major clients, enable us to carry out comprehensive site trials on our products and systems prior to launch.

## Introduction

### SpecSure® Gyproc Systems Guarantee



## SpecSure® is a warranty that confirms Gyproc systems<sup>1</sup> will perform as specified for the lifetime of the building<sup>2</sup>

### The Gyproc promise

SpecSure® is our guarantee that the Gyproc system you have chosen:

- Comprises only components that are designed to work together to deliver the specified level of performance
- Has been developed utilising the technical expertise and experience of Ireland's leading drylining specialists
- References claimed performances that have been tested in UKAS accredited fire, acoustic and structural test laboratories. We regularly retest our products to ensure consistency of performance when incorporated within our systems
- Will be supported, on and off-site, as required at every stage of the project by our team of drylining technical experts
- Will achieve every performance as claimed and will continue to do so throughout the life of the building
- Will be repaired or replaced by Gyproc in the unlikely event of system performance failure attributed to a defective product

Full terms and conditions of the SpecSure® warranty can be found at [Gyproc.ie/specsure](https://gyproc.ie/specsure)

<sup>1</sup> Systems comprised of genuine components specified by Gyproc and installed as stipulated with our installation instructions provided in The White Book, on [gyproc.ie](https://gyproc.ie) or in written guidance provided by our technical support team. Timber framed walls and floors are not covered by our SpecSure® lifetime system warranty.

<sup>2</sup> Performance specification as detailed in The White Book, on [gyproc.ie](https://gyproc.ie) or from formal written technical specifications issued by our technical support team.

### To qualify for SpecSure®

Specify, install and finish Gyproc systems in line with our recommendations provided in the current Gyproc White Book or written guidance provided by our technical support team.

The systems must comprise only genuine Gyproc and Isover components specified by Gyproc. We cannot guarantee that the use of other components will meet our rigorous performance and quality standards when installed in our tested systems.

**Kieran Holohan**  
Managing Director

**By choosing a Gyproc system developed, tested and supported by drylining specialists, you're protecting the future of your building and its users.**

# Introduction

## Environmental consideration

### Sustainable solutions

For Gyproc, managing sustainability is not a new idea; it is how we've always done business and will underpin how we meet the challenges of the future.

Sustainability is a challenge we embrace. It enables us to balance our responsibilities, not only to specifiers and installers, but to all of our customers, suppliers, employees and the communities in which we work and live.

We recognise that manufacturing and construction is often perceived as making heavy demands on the environment. We have committed to minimise our impact on valuable natural resources, striving to provide products and systems that enable customers to build in a more sustainable and responsible way.

We ensure that our solutions don't just meet your needs today, but also meet all of our needs tomorrow. Sustainability is an important issue and we are keen to meet it head-on by making responsible decisions. The way we manage our business and care for our employees is as important to our future as the way in which we care for the environment.

Sustainable development relies on the balancing of social, economic and environmental objectives. In any given construction project it is vital that these three pillars are considered in order to deliver a sustainable solution.



### Social

Our people are our business. We ensure a safe, healthy workplace, give them respect and nurture their talents to take our business forward. We train for leadership and build on employee knowledge through an extensive Technical Development Program at our Saint-Gobain Technical Academy.



### Economic

We work hard to ensure our business remains viable. We work closely with our supply chain to source materials responsibly and sustainably, driving issues such as Health and Safety and responsible business management throughout our supply base. Our Responsible Sourcing Strategy means our UK manufactured plasters and plaster boards qualify for extra credits in leading environmental assessment schemes.



### Environmental

We are accredited for managing key areas like compliance, energy management, water usage and waste reduction across our business.

#### Key facts

- Zero plasterboard waste to landfill *ISO 9001* Quality Management certification
- *ISO 14001* Environmental Management certification across all sites
- *ISO 50001* Energy Management certification
- *OHSAS 18001* Safety Management certification
- *BES 6001* Responsible Sourcing of Construction Products across our Gyproframe metal, Glasroc & Hard Coat products
- More than 5,000 hours employee and customer training last year

▶ Refer to C02. S01. P57 for further information.

## Introduction

### Responsible sourcing

The supply chain plays an integral part in sustainability performance. We are therefore committed to acting responsibly in our dealings with our customers and, since 2007, have implemented a strategy to ensure our suppliers do the same.

Our strategy covers three areas:

#### Health and Safety

*Health and Safety must be as important to our suppliers as it is to us. We work closely with our suppliers and carry out SUSA (Safe And Unsafe Acts) and SMAT (Senior Management Audit Tool) audits to help them establish their own Health and Safety culture.*

#### Environment

*As we do, our suppliers must care for the environment, from the way they adhere to legal requirements, to the way they source their raw materials and deliver their products. Our procurement team carry out monitoring and measuring programs with EMAT (Environmental Management Audit Tool) audits with our suppliers to understand, evaluate and reduce their impact on both the global and local environment.*

#### Material stewardship

*It is important, for our own future, and that of our customers, that our suppliers act responsibly and pro-actively in the ownership and management of their own businesses and products.*

Our strategy is based on the framework recommended as sustainable best practice by Government. We set objectives and targets, implement programs of work and review our systems to ensure that we sustain progress in each of these areas.



### Important information

We have obtained a *BES 6001* 'Excellent' rating for UK manufactured plaster, plasterboard and metal partition systems, which have been awarded the highest possible rating to *BES 6001*.

In addition we have a *BES 6001* 'Very Good' rating for all locally manufactured plasters and plasterboard products.

Achieving *BES 6001* 'Excellent' means that certified products will achieve Tier Two under MAT 03 in BREEAM 2011, providing 3.5 of a maximum 4 points. It also means that all certified products are Tier One under MAT 2 for Code for Sustainable Homes, making it easier for customers to achieve a higher number of points towards credits at no additional cost.



## Introduction

### Life Cycle Assessments (LCA)

We want to make the selection of sustainable solutions simpler for our customers. In order to do this we have begun developing Life Cycle Assessments (LCA) for our product ranges.

Since December 2013 we have published eleven Environmental Product Declarations (EPDs) across two brands, Gyproc and Isover. The independently verified EPD, which are the result of the Life Cycle Assessment (LCA) process, are designed to give users information on the environmental performance of our products across numerous impact categories.

“Presenting a more transparent and complete evaluation than traditional methods often limited to Energy and CO<sub>2</sub> emissions.”

**Fintan Smyth**  
Building Physics Manager

The underlying LCA considers the entire life cycle of a product solution from cradle-to-grave. As part of the assessment, a comprehensive range of factors are considered, including the potential environmental effects of raw materials, the manufacturing process, logistics, installation, performance in use and finally the product at the end of its life. EPD include information on raw material use, energy use and efficiency, content of materials and chemical substances, emissions to air, soil and water and waste generation – this enables our customers to understand the full environmental impacts of the product ranges being selected.

“The way in which the potentially complex raw material transport and multiple production site issues have been dealt with, display clear LCA thinking. The clear presentation of results and calculations is also commended.”

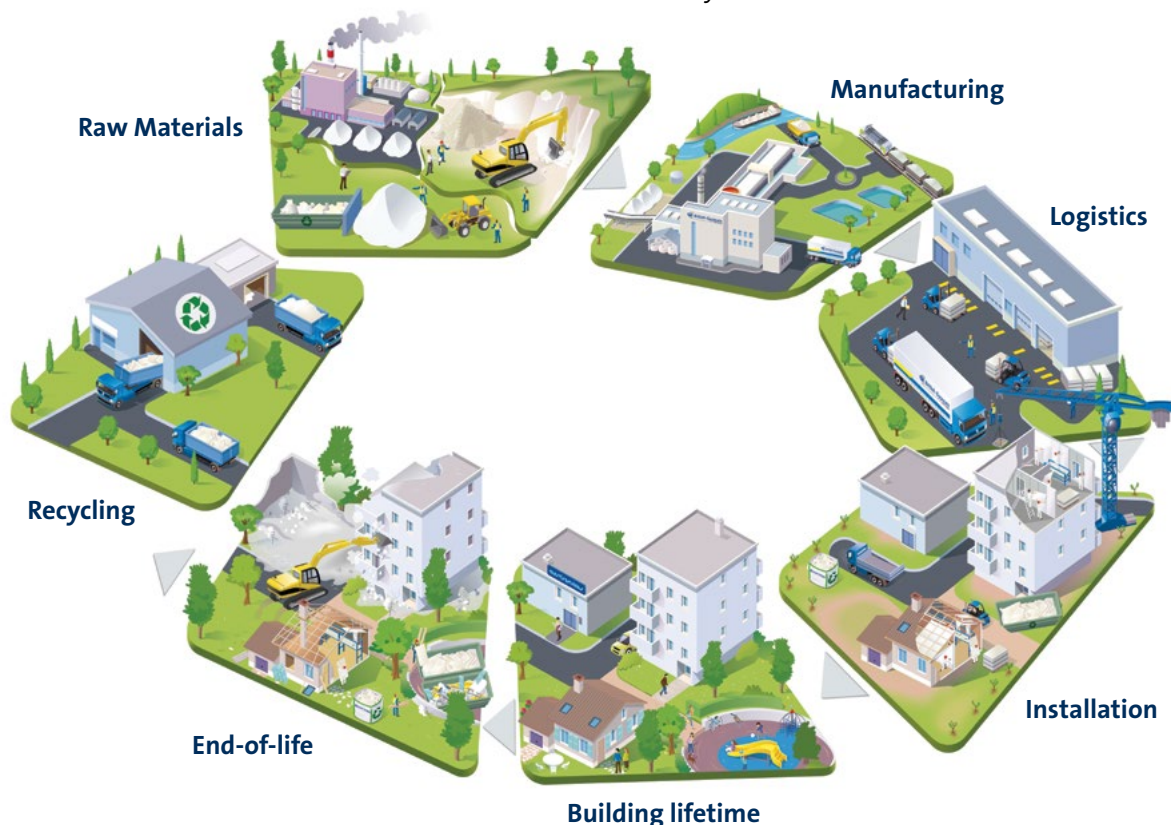
**Dr Andrew Norton**  
Renueables, EPD Verifier

The EPD results also enable us to understand at which stage our products have the greatest impact on the environment. We can therefore make better informed decisions on processes involved in the production of current and new products, as well as taking steps to minimise the environmental impact of our products across their lifecycle. EPD also provide clear evidence for environmental building certification schemes, meeting credit requirements in BREEAM, for example.

The first eleven completed EPDs were for Gyproc Finish Plasters, 12.5mm Gyproc WallBoard, 12.5mm Gyproc FireLine, 15mm Glasroc F FIRECASE, 6mm Glasroc F MULTIBOARD, 12.5mm Glasroc H TILEBACKER, Gypframe metal components, 12.5mm Gyptone BIG and 10mm Gyptone Ceiling Tiles with ActivAir®, Gyproc Hard Coat plaster and Isover Spacesaver.

“This is just the beginning of the journey. We are developing further EPD for our solutions and these will be rolled out in due course.”

**Rachel Morris**  
LCA Analyst



## Introduction

### Building Information Modelling (BIM) and The White Book

To integrate BIM into **The White Book** we have designed an online tool to help streamline the specification process for you. Our **System Selector** allows you to search and filter through tested Gyproc plaster and drylining solutions to select the right specifications.

Our **System Selector Tool**, enables you to filter by a variety of performance requirements, such as fire and acoustics, and be presented with a relevant solution.

Building Information Modelling (BIM) Revit data, Specification clauses and product and system information are then available to download for the chosen solutions. This allows you to retrieve important information in a few easy steps.

By making specification information available for the full range of solutions, we aim to help you to explore the key physical and functional characteristics of systems at the click of a button. The BIM data files also feature product and system performance information, which can streamline the design, build and maintenance process to save the building user time and money.



#### Handy hint

Use the new **System Selector** to simplify the specification process, making it quick and easy to access solutions appropriate for any given project you're working on.

► Refer to [gyproc.ie](https://gyproc.ie)

# CO2

Technical performance

## Technical performance and principles of system design

This section provides guidance on the technical performance and principles of system design. Reference is made to relevant regulatory requirements and International Standard Organisation (ISO), European (EN) and British (BS) standards. It considers the various aspects of performance, both from a building theory and practical perspective



# Technical performance and principles of system design

## Introduction

### **Fire** ▶ Refer to C02. S01. P16)

Fire performance includes fire resistance, fire protection and reaction to fire, which are relevant for compartmentation, structural steelwork and surface spread of flame respectively. The assessment of systems in accordance with both British Standard (BS) and European Standard (EN) fire testing criterion is acceptable for compliance with Building Regulations. However, it is important to recognise the impact of selecting EN over BS assessed systems. EN fire testing standards are more onerous and therefore a higher level of fire engineering is often required when compared to equivalent BS compliant specifications.

### **Building acoustics** ▶ Refer to C02. S01. P21)

Building acoustics includes both sound insulation (airborne and impact) and sound absorption. A key design aspect is how the drylined building element interacts with the associated structure. If this is ignored, the performance of the element can be completely nullified. The key factors that are covered include gap sealing, why it is preferable to take the partition through to the structural soffit, and why it is important to design out flanking sound transmission.

### **Robustness** ▶ Refer to C02. S01. P37)

Consideration needs to be given to the robustness of drylining systems, particularly if required to resist crowd pressure, impacts and abrasions and wind loading. The stiffness of a partition is critical to this and is therefore considered when determining the recommended maximum height.

### **Service installations** ▶ Refer to C02. S01. P41)

Drylining elements need to be fully compatible with building services such as electrical, plumbing, heating and ventilation etc. This means that service installation should be fully assessed at the design stage to ensure that the layout of the services is compatible with the ceiling module or location of stud work. Furthermore, the weight of fixtures and fittings must be considered at the design stage to ensure that the appropriate system with correct detailing is specified.

### **Thermal insulation and condensation** ▶ Refer to C02. S01. P49)

Thermal comfort within a building is primarily dictated by the constructed elements ability to provide thermal insulation and maintain air-tightness combined with the heating and ventilation strategy adopted.

It is also important that appropriate vapour control measures are applied to manage the risk of condensation that can lead to poor occupancy health and building durability.

Good air quality and fabric energy efficiency assist in optimising the performance of the building.

### **Sustainability** ▶ Refer to C02. S01. P57)

Commitment to sustainability and minimising impacts on valuable natural resources is fundamental to our policies and is recognised in many ways, for example, the achievement of *ISO 14001* and *BES 6001* third party certification. Use of our products and systems not only gives sustainable assurances but can also assist designers in meeting specific criteria within a number of different environmental and sustainability standards and schemes e.g. BREEAM, LEED and the Irish Green Building Council's Home Performance Index (HPI) system.

Notably, our lightweight products and systems are highly suitable for low impact alterations to buildings, in particular gypsum is a natural product and may be fully recycled. Gypframe metal components may also be reused or recycled and similarly Isover mineral wool insulation may be reused.

# Technical performance and principles of system design

## Fire

### Legislation, guidance and insurance

#### Building Regulations - Fire Safety

Technical Guidance Document B (RoI) and Technical Booklet E (NI) are among the series of approved documents that provide practical guidance on meeting the fire safety requirements of Building Regulations.

The documents classify the use of a building into purpose groups and specify minimum periods of fire resistance to be achieved by the building elements. The periods of fire resistance vary according to the classification and the size of building. The greater the fire hazard a building presents, then the greater the period of fire resistance required to protect the elements within the building. The materials used to form the internal surfaces of the building are also controlled to reduce the risk of fire growth and internal fire spread.

#### Healthcare buildings

Hospitals and healthcare environments by their very nature contain people who are at risk from fire. Health Technical Memorandum (HTM) 05 series UK documents may also be useful in the fire safety design of healthcare facilities. These documents provide guidance on the standards of fire safety expected in healthcare facilities and include recommendations on internal fire spread, elements of structure, compartmentation, fire hazard areas, hospital streets, penetrations, protected shafts, ceiling membranes, cavity barriers and fire-stopping.

#### Educational buildings

The design of fire safety in schools is covered by TGD 021 from the Department of Education & Skills (RoI) and Building Bulletin 100 UK may also be useful.

#### Fire protection for structural steel in buildings, ASFP Yellow Book

Publication prepared by the members of the Association for Specialist Fire Protection (ASFP). Presenting the theory behind, and methods for, fire protection of structural steelwork to comply with Building Regulations. It provides a comprehensive guide to proprietary materials and systems, all of which are manufactured, marketed or applied on site by members of ASFP.

### Principles of fire performance

#### Fire growth

The choice of materials for walls and ceilings can significantly affect the spread of fire and its rate of growth through a building, even though they are not likely to be the materials first ignited. The specification of linings is particularly important in circulation spaces where surfaces may offer the main means by which fire spreads, and where rapid spread is most likely to prevent occupants from escaping.

Two properties of lining materials that influence fire spread are:

- The rate of flame spread over the surface when it is subject to intense radiant heating
- The rate at which the lining material gives off heat when burning

#### Compartmentation

The spread of fire within a building can be restricted by sub-dividing it into compartments separated from one another by walls and/or floors of designated fire resisting construction.

The two key objectives are:

- To prevent rapid fire spread, which could trap occupants within the building
- To reduce the chance of fires becoming large, which is more dangerous – not only to occupants and fire service personnel, but also to people in the vicinity of the building

The appropriate degree of sub-division depends on:

- The use and fire loading of the building, which affects the potential for fires and their severity, as well as the ease of evacuation
- The height to the floor of the top storey in the building, and the maximum distance from a route of safe passage, which is an indication of the ease of evacuation and the ability of the fire service to intervene effectively

# Technical performance and principles of system design

## Fire (continued)

### Structural fire precautions

Premature failure of the structure can be prevented by fire protecting loadbearing elements.

The purpose in providing the structure with fire resistance is:

- To minimise the risk to the occupants, some of whom may have to remain in the building for some time (particularly if the building is a large one), while evacuation proceeds
- To reduce the risk to fire fighters engaged on search and rescue operations
- To reduce the danger to people in the vicinity of the building who may be hurt by falling debris, or because of the impact of the collapsing structure on other buildings

### Fire limit state

In structural design terms, fire is considered to be an accidental limit state, i.e. an accidental occurrence, and one for which the structure must not collapse. Loads and their factors of safety used in design at the fire limit state reflect the low probability of occurrence.

Typically, structural members that are designed to be fully stressed under normal conditions would be subject to a load ratio of 0.5 to 0.6 under fire conditions. Within this book, loadbearing floors and partitions are quoted with respect to a stated load ratio. Many constructions have been tested at a conservative load ratio of 1.0 (100%) despite the fire state being an accidental load.

### Structural behaviour of timber in fire

Although it is combustible, the charring that occurs around timber when it is exposed to fire helps to slow down its rate of degradation and maintain its structural capacity. Timber has a low thermal expansion coefficient, which minimises the possibility of protective layers and charred materials becoming displaced. It also has a low thermal conductivity, which means that undamaged timber immediately below the charred layer retains its strength. Generally, it may be assumed that timber will char at a constant rate when subjected to the standard heating conditions of the test furnace. The rate of reduction in the size of structural timber can be taken as 15mm to 25mm (depending on species) in 30 minutes for each face exposed; different rates apply where all faces are exposed. The undamaged timber can be assessed for structural stability using standard design guides in conjunction with stress modification factors.

For partitions tested with high load ratios it should be noted that when the timber is exposed to fire, the exposed face will shrink causing differential thermal movement. This can be important for axially loaded sections, as it introduces a degree of eccentricity, which may cause a loss of loadbearing capacity.

### Structural behaviour of steel in fire

Steel generally begins to lose strength at temperatures above 300°C and eventually melts at about 1500°C. Importantly for design, the greatest rate of strength loss is in the range of 400°C to 600°C.

Using fire design codes such as the Structural Eurocodes EC3-1.2 and EC4-1.2 (designated *BS EN 1993-1-2: 2005* and *BS EN 1994-1-2: 2005*), the load on the structure at the time of the fire can be calculated by treating it as an accidental limit state. If used, this will allow designers to specify to the fire protection contractor a limiting or failure temperature for a given structural section. The fire protection contractor will then be able to use the required thickness of material to ensure that the steel section does not exceed this temperature within the fire resistance period. This process could be simplified by the designer specifying a maximum steel temperature, based on the worst case, for all beams or columns on one floor level.

Buildings that are not primarily used for storage, e.g. offices, residential units, schools and hospitals, have a high percentage of non-permanent loads. For this type of building, the structural Eurocode *BS EN 1991-1-1: 2002* assumes that a proportion of the design load will not be present at the time of the fire. Other types of buildings, such as warehouses and libraries, are primarily used for storage, so a high percentage of the load is permanent. The codes allow for no reduction in design load for the fire condition.

The fire testing standards effectively base the failure criteria for loadbearing elements on strength. However, beams should be designed at the fire state limit as well as in the cold state limit.

Columns are frequently designed so that a single length will be two or three storeys high. The lowest storey will be loaded; the highest and the upper storey will be lightly loaded. In buildings with a degree of non-permanent load (in terms of duration and magnitude), the load ratio of the structural members is unlikely to be greater than 0.6. In storage buildings, where the majority of load is permanent, the load ratio would normally be higher, but is unlikely to be greater than 0.65.

In C03. S01. P67 – Steelwork encasement systems, the thicknesses of protection required are specified for design temperatures of 550°C, unless otherwise stated. It is the responsibility of the design engineer, using design codes such as *BS EN 1993-1-2: 2005*, to specify the appropriate limiting steel temperatures.

The loss of strength of cold-formed steel at elevated temperatures exceeds that of hot-rolled steel by between 10% and 20%. Expert advice should be sought in determining the strength reduction factor at the limiting temperature.

# Technical performance and principles of system design

## Fire (continued)

### Why gypsum is so effective in fire

Our plasters, plasterboards and specialist boards provide good fire protection due to the unique behaviour of gypsum in fire. When gypsum-protected building elements are exposed to fire, dehydration by heat (calcination) occurs at the exposed surface and proceeds gradually through the gypsum layer.

Calcined gypsum on the exposed faces adheres tenaciously to uncalcined material, retarding further calcination which slows as the thickness of calcined material increases. While this continues, materials adjacent to the unexposed side will not exceed 100°C, below the temperature at which most materials will ignite, and far below the critical temperatures for structural components. Once the gypsum layer is fully calcined, the residue acts as an insulating layer while it remains intact.

Gypsum products are excellent performers in terms of reaction to fire, as the endothermic hydration reaction requires energy to be taken from the fire, so gypsum is a negative calorific contributor.

### Fire resistance test standards

Building Regulations and supporting documentation require elements of structure and other building elements to provide minimum periods of fire resistance, expressed in minutes, which are generally based on the occupancy and size of the building.

Fire resistance is defined in 'the ability of an element of building construction to withstand exposure to a standard temperature / time and pressure regime without loss of its fire separating function or loadbearing function or both for a given time' (*BS 476: Part 20: 1987*).

The fire separating function of a construction is defined as the integrity and insulation performance.

- **Integrity** is the ability of a separating element to resist collapse, the occurrence of holes, gaps or cracks through which flames and hot gases could pass and sustained flaming on the unexposed face.
- **Insulation** is the ability of a separating element to restrict the temperature rise of the unexposed face to below specified levels.
- **Loadbearing function** is the ability of the loadbearing element to support its test load without deflecting beyond specified limits.

Conformance with Building Regulations can be demonstrated with test reports showing the system has been tested for the imperforate system in accordance with European (EN) or British (BS) fire resistance test standards, however, for service penetrations or other junctions, please check with the Gyproc technical department where such details are required to meet the European Norm.

### EN fire resistance test standards

The Construction Products Regulation (CPR) within European legislation is designed to enable free trade across Europe in construction products. To enable free trade, harmonised test standards for technical performance are required. The area of technical performance most affected by this requirement is fire performance.

Fire resistance methods used across Europe were similar but the severity of furnaces varied due to factors such as different fuel sources and furnace geometry. To improve consistency between different furnaces, plate thermometers were introduced to measure the heat flux to which samples are exposed. The use of plate thermometers means the EN fire resistance test can be more severe, especially during the first 30 minutes of exposure when compared with BS fire resistance tests.

EN fire resistance test standard also imposes strict rules governing the use of tests to cover specific end use scenarios (field of application). This restricted field of application has most effect on partitions that are built with heights above 4m, as they may need to have enhanced levels of fire protection.

To claim up to 3m, the partition has to be tested at a height of 3m in the fire resistance test. To claim up to 4m, the partition has to pass the test with a partition test height of 3m and not deflect laterally by more than 100mm during the test.

To claim above 4m, the partition has to undergo an engineering appraisal where the thermal bow and strength loss of the steel studs are taken into account. This means that the same partition may have different quoted heights at different fire resistance durations. The only alternative to using an engineering appraisal is to conduct a test at the height under consideration.

We have conducted an extensive series of EN fire resistance tests on partitions with heights up to 6m. Data from these tests are used within the performance tables. Insulation materials, such as glass and stone mineral wool, can affect the fire resistance of a partition. These materials can provide additional insulation / integrity performance but can also increase the thermal bow of the partition and therefore reduce the partition height that can be claimed. Consequently, within the performance tables, there are instances where the partition height is reduced when a quilt is included within the cavity of the partition. It cannot be assumed that adding a quilt to a partition specification will not impact on its fire resistance.

# Technical performance and principles of system design

## Fire (continued)

### EN fire resistance and its application to Gyproc systems

The EN fire resistance periods claimed for systems in this document are evaluated in accordance with the relevant EN fire resistance test standards.

#### *BS EN 1364-1: 2015*

Specifies a method for determining the fire resistance of non-loadbearing walls.

#### *BS EN 1365-1: 2012*

Specifies a method for determining the fire resistance of loadbearing walls.

#### *BS EN 1365-2: 2014*

Specifies a method for determining the fire resistance of loadbearing floors and roofs.

#### *BS EN 1364-2: 1999*

Specifies a method for determining the fire resistance of non-loadbearing ceilings.

#### *BS EN 13381-4: 2013*

Test methods for determining the contribution to the fire resistance of structural members: Applied protection to steel members.

#### *ENV 13381-2: 2014*

Test methods for determining the contribution to the fire resistance of structural members. Vertical protective membranes.

### BS fire resistance test standards

As both EN and BS fire resistance standards are acceptable for showing compliance with Building Regulations, this book shows tables for systems tested in accordance with both EN and BS standards.

Unlike the EN test standards the BS test standards do not impose restrictions with respect to maximum partition height. Within the *BS 476: Part 22* testing regime, the partition height in the fire state is not considered, and if a partition passes the fire test at 3m it is deemed to be suitable in fire resistance terms for any possible heights. Under the BS system, the cold state height would be the maximum height claimed regardless of the fire duration required.

### BS fire resistance and its application to Gyproc systems

The BS fire resistance periods claimed for systems in this document are evaluated in accordance with the relevant BS fire resistance test standards.

#### *BS 476: Part 20: 1987*

Describes the general procedures and equipment required to determine the fire resistance of elements of construction.

#### *BS 476: Part 21: 1987*

Describes the specific equipment and procedures for determining the fire resistance of loadbearing elements.

#### *BS 476: Part 22: 1987*

Describes the procedures for determining the fire resistance of non-loadbearing elements.

#### *BS 476: Part 23: 1987*

Describes the specific equipment and procedures for determining the contribution made by components to the fire resistance of structures.

## Reaction to fire test standards

Reaction to fire is the measurement of how a product will contribute to the development and spread of a fire.

The choice of materials for walls and ceilings can be of critical importance when designing a building especially in spaces which occupants will use when escaping from a potential fire.

### EN reaction to fire

The European Classification System (Euroclass), devised for the classification of 'reaction to fire', has been introduced as part of the ongoing harmonisation of European standards. Reaction to fire has traditionally been assessed using at least 30 different national standards across Europe. The Euroclass system includes tests designed to better evaluate the reaction of building products to fire.

The Euroclass system predicts the performance of building materials in a real fire more accurately than the British Standard classification system.

The Euroclass test methodology is built around the Single Burning Item (SBI) test method (*BS EN 13823: 2010+A1:2014*), which is an intermediate scale test to evaluate the rate of fire growth from a waste paper basket fire positioned in the corner of a room.

Other tests used in the classification system are the non-combustibility test (*BS EN ISO 1182: 2010*), heat of combustion test (*BS EN ISO 1716: 2010*) and direct flame impingement test (*BS EN ISO 11925-2: 2010*).

The overall reaction to fire performance of a construction product or building element is presented in a classification report in accordance with *BS EN 13501-1: 2007*. This report uses the results from the relevant test methods and determines the Euroclass category rating for the product.

Gypsum products are intrinsically fire safe products and generally fall into the higher Euroclass classifications. Plasterboard is subject to a 'classification without further test' decision. This means that any type of plasterboard can be classified as A2, so long as the paper grammage of the

# Technical performance and principles of system design

## Fire (continued)

liner does not exceed 220g/m<sup>2</sup> and the core of the board is classified as A1 (non-combustible). Any plasterboard product with a paper liner in excess of this grammage is required to be tested.

All our plasterboard products manufactured in accordance with *BS EN 520: 2004* are designated Euroclass A2. All our Glasroc products manufactured in accordance with *BS EN 15283-1: 2008* are designated Euroclass A1.

### BS reaction to fire

The British Standard classification system determines the reaction to fire performance of a product based upon the performance in the fire tests *BS 476 Parts 4, 6, 7, and 11*. These fire test methods are material tests and measure the characteristics of the surface of the material, whereas the EN tests are measurements of the performance of the construction product in an arrangement representative of end use.

To help provide maximum fire safety in buildings, certain building elements need to be constructed of non-combustible materials. A building material is designated as non-combustible if it satisfies performance criteria when tested in accordance with:

*BS 476: Part 4: 1970 (1984) Non-combustibility test for materials.*

*BS 476: Part 11: 1982 (1988) Method for assessing the heat emission from building materials.*

Glasroc boards are designated as non-combustible materials. Some construction products can be described as materials of limited combustibility provided they satisfy the following requirements:

- (a) Any non-combustible material (listed in Technical Guidance Document B, section A18 (RoI) or Technical Booklet E, section 1.9 (NI)).
- (b) Any material of density 300kg/m<sup>3</sup> or more, which does not flame or cause a 20°C temperature rise when tested to *BS 476: Part 11 under national classes*.
- (c) Any material with a non-combustible core at least 8mm thick having combustible facings (on one or both sides) not more than 0.5mm thick. Where a flame spread rating is specified, these materials must also meet the appropriate test requirements under National classes.
- d) a material classed as A2-s3,d2 per BS 13501-1 under European classification.

Gyproc plasterboards are all designated materials of limited combustibility or greater.

### Surface spread of flame

Flame spread over wall and ceiling surfaces is controlled by providing materials that are either non-combustible or materials of limited combustibility. Combustible materials

(or certain materials of limited combustibility that are composite products) when tested to the standard below, are classified Class 1, 2, 3 or 4. Class 1 provides the greatest resistance to surface spread of flame:

*BS 476: Part 7: 1997 Surface spread of flame tests for materials.*

The exposed surfaces of our plasterboards and specialist boards are all designated Class 1.

### Fire propagation

Investigations concerned with the growth of fires in buildings show that the surface spread of flame test does not measure all the properties that are relevant for placing combustible materials in the proper order of hazard. Such considerations led to the test which is described in *BS 476: Part 6: 1989 Method of test for fire propagation for products*. This test takes into account the amount and rate of heat evolved by a specimen whilst subjected to a specified heating regime in a small furnace. The standard describes the method of calculating the results to obtain indices of performance, which help to determine the suitability of combustible wall and ceiling lining materials when used in areas requiring maximum safety.

### Class 0

In addition to the degree to which combustible materials used as wall and ceiling linings can contribute to the spread of flame over their surfaces, consideration must also be given to the amount and rate of heat evolved by these materials when used in areas requiring maximum safety. Building Regulations, by means of associated documentation, make provisions that wall and ceiling surfaces must be Class 0 in circulation spaces (which are often escape routes) and in other specific situations.

In Technical Guidance Document B (RoI) or Technical Booklet E (NI), a Class 0 material is defined as either:

- (a) composed throughout of materials of limited combustibility (this term includes non-combustible materials)
- or
- (b) a Class 1 material that has a fire propagation index (I) of not more than 12 and a sub-index (i1) of not more than 6.

Materials of limited combustibility are those achieving an EN reaction to fire classification of A2-s3, d2 or greater.

For further information, please refer to Technical Guidance Document B (RoI) or Technical Booklet E (NI). The exposed plasterboard surfaces of Gyproc specialist boards are designated Class 0 in accordance with current building regulations.

Although Class 0 is the highest performance classification for lining materials, it is not a classification identified in any harmonised test or standard.

# Technical performance and principles of system design

## Building acoustics

### Principles of building acoustics

Building acoustics is the science of controlling noise in buildings, including the minimisation of noise transmission from one space to another, and the control of noise levels and characteristics within a space.

Noise can be defined as sound that is undesirable, but it can be subjective and depends on the reactions of the individual. When a noise is troublesome, it can reduce comfort and efficiency. If a person is subjected to noise for long periods, it can result in physical discomfort or mental distress. Within homes, a noisy neighbour can be one of the main problems experienced in attached housing. It's estimated that up to 300,000 people in Ireland have had their lives disturbed by noisy neighbours.

The best defence against noise is to ensure that proper precautions are taken at the design stage and during construction of the building. The correct acoustic climate must be provided in each space, and noise transmission levels should be compatible with the building's usage. Retrofitted remedial measures taken after occupation can be expensive and inconvenient.

The term 'building acoustics' covers both sound insulation and sound absorption.

### Sound insulation

Sound insulation is the term describing the reduction of sound that passes between two spaces separated by a dividing element.

In transmitting between two spaces, the sound energy may pass through the dividing element (direct transmission) and through the surrounding structure (indirect or flanking transmission). When designing for optimum sound insulation, it's important to consider both methods of transmission. The walls or floors, which flank the dividing element, constitute the main paths for flanking transmission, but this can also occur at windows, doorways, heating or ventilation ducts, for example.

The acoustic environment of the room and/or the building, and the ability to reduce or eliminate air paths in the vicinity of the sound reducing element, these include doorsets, glazing, suspended ceiling cavities, ductwork, etc. will have a significant effect on its performance. For these reasons it is unlikely that figures quoted from laboratory test conditions will be achieved in practice. When the background noise is low, consideration may have to be given to a superior standard of sound insulation performance in conjunction with the adjoining flanking conditions.

In any existing sound insulation problem, it is essential to identify the weakest parts of the composite construction.

The Building Regulation requirements regarding the sound insulation of walls and partitions only relate to the transmission of airborne sounds. These include speech, musical instruments, loudspeakers and other sounds that originate in the air. In most cases, floors must also resist the transmission of impact sounds, such as heavy footsteps and the movement of furniture.

#### Indirect paths (flanking transmission)

Flanking sound is defined as sound from a source room that is not transmitted via the separating building element. It is transmitted indirectly via paths such as windows, external walls and internal corridors. Refer to figure 1.

It is imperative that flanking transmission is considered at the design stage and construction detailing is specified so as to eliminate or at least to minimise any downgrading of the acoustic performance. The sound insulation values quoted in system performance tables are laboratory values and the practicalities of construction will mean that acoustic performances measured in the laboratory will be difficult to achieve on site.

One of the main reasons for this difference is the loss of acoustic performance via flanking transmission paths. Good detailing at the design stage will minimise this effect and optimise the overall levels of acoustic privacy achieved.

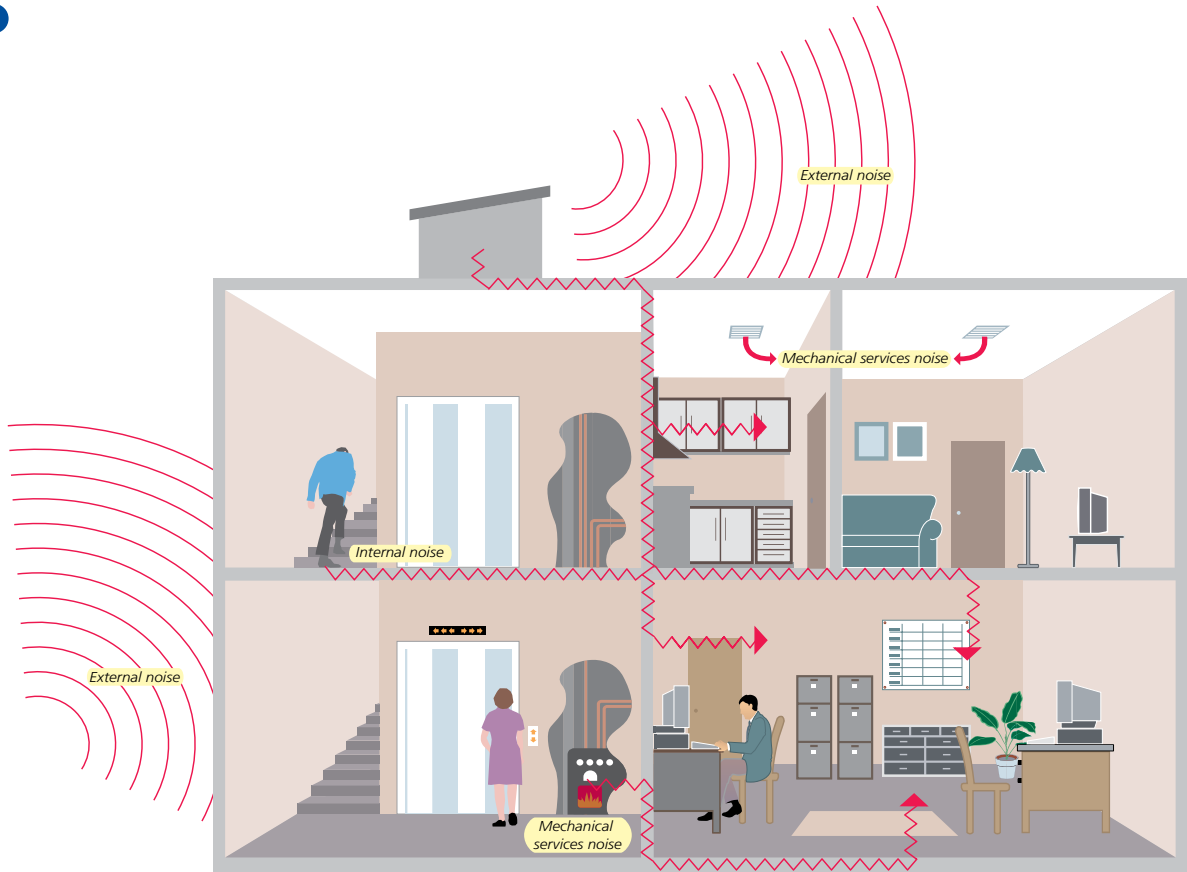
If designing for residential units, design advice on flanking details must be followed to maximise the possibility of achieving the specified acoustic performance. It is imperative that the design advice is followed, otherwise site sound insulation values may not meet the minimum standards required by Building Regulations and expensive remedial treatment will be required.

Small openings such as gaps, cracks or holes will conduct airborne sounds and can significantly reduce the sound insulation of a construction. For optimum sound insulation a construction must be airtight. Within masonry construction, most gaps can be sealed at the finishing stage using Gyproc Airtite Quiet, Gyproc plaster or Gyproc jointing compounds. At the base of the partition, gaps will occur, particularly when boards are lifted tight to the ceiling. Small gaps or air paths can be sealed with Gyproc Sealant.

# Technical performance and principles of system design

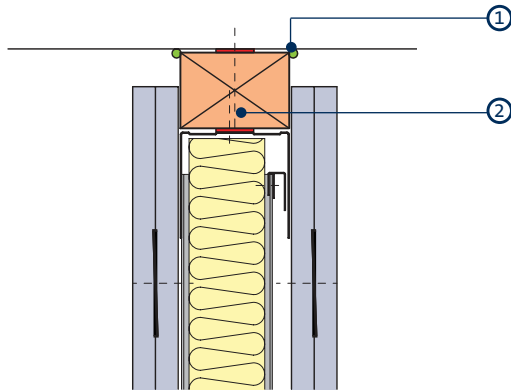
## Building acoustics (continued)

1



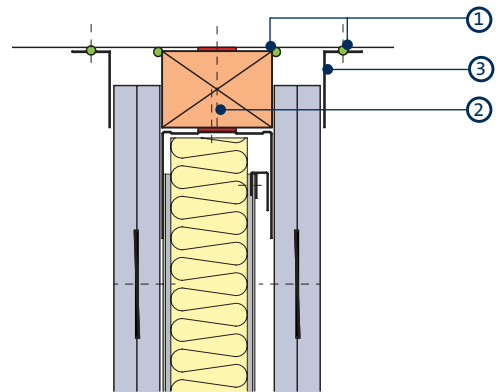
Common flanking paths

2



Deflection head A (subject to fire performance)

3



Deflection head B (subject to fire performance)

- 1 Gyproc Sealant for optimum sound insulation
- 2 50mm timber head plate equivalent to channel width forming fire-stop

- 3 Gypframe GA4 Steel Angle to minimise loss of sound insulation performance due to air leakage

# Technical performance and principles of system design

## Building acoustics (continued)

### Acoustic performance of deflection head details

Deflection heads, by definition, must be able to move and, therefore, achieving an airtight seal is very difficult without incorporating sophisticated components and techniques. Air leakage at the partition heads will have a detrimental effect on acoustic performance of any partition.

The approach shown in figure 2 could, for example, result in a loss of around 4dB to 5dB due to air leakage, in addition to any performance lost due to flanking transmission.

Where acoustic performance is a key consideration, steps can be taken to minimise this loss of performance. Figure 3 shows the generally accepted method of achieving this and, provided that care is taken to ensure a tight fit between the cloaking angle and lining board surface, the loss in performance can be reduced.

Other factors, such as flanking transmission through the structural soffit, can significantly affect the overall level of sound insulation. Therefore, other measures may need to be taken.

- A suspended ceiling installed on both sides of the partition may provide a similar cloaking effect to that of steel angles
- **CasoLine MF** incorporating imperforate plasterboard can deliver a similar reduction in air leakage at the partition head. A tight fit between the ceiling perimeter and the surface of the partition lining board is important, although mechanically fixed perimeters are not essential

Ceilings with recessed light fittings may be less effective and if these cannot be sealed in some way, the installation of cloaking angles at the partition head should be considered. A suspended ceiling may also reduce the level of sound flanking transmission via the soffit.

Where perforated ceilings are used, e.g. Gyptone, the angles as shown in figure 3 are recommended. However, if the distance between the ceiling and the deflection head is greater than 200mm, and the ceiling plenum contains Isover insulation (minimum 25mm), the angles may not be required.

### Partition to structural steelwork junctions

When designing the layout of rooms requiring separation by sound insulating walls abutting structural steelwork, consideration should be given to the potential loss of sound insulation performance through the steelwork.

Figures 4 to 7 are example details relating to a typical scenario where a partition is specified against a requirement of  $R_w$  50dB. Although these details refer to structural steel column abutments, similar principles apply when abutting structural steel beams. We recommend that these details are checked by an Acoustic Consultant, in particular the performance via the flanking structure.

### Sound by-passing a partition via the void above a suspended ceiling

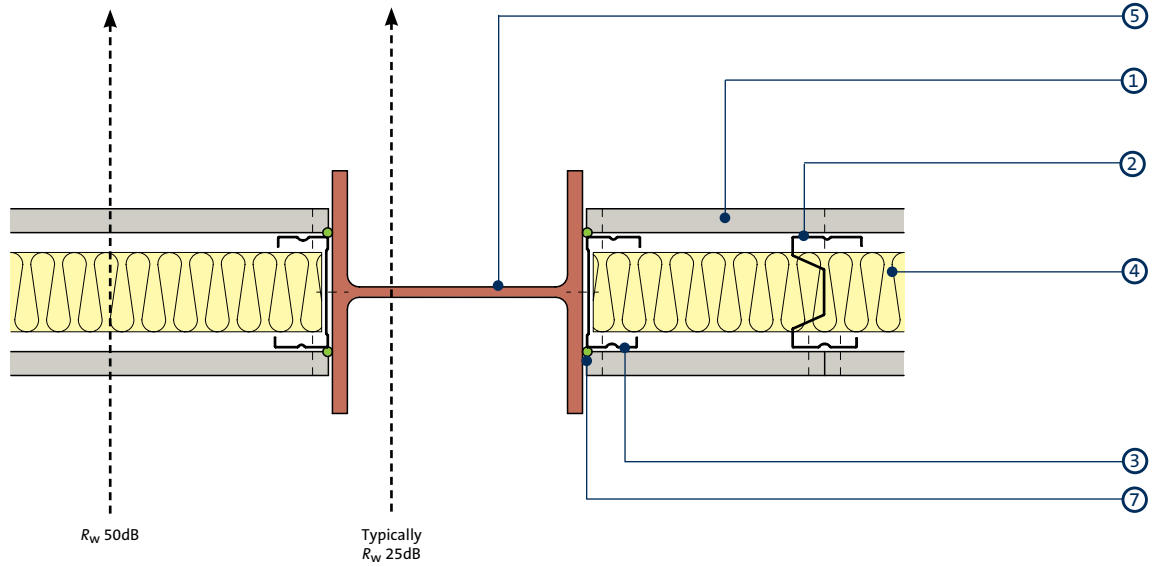
This is a common source of sound transmission, particularly where the ceiling is absorbent to sound. Sound can easily travel through a perforated tile, or lightweight suspended ceiling, and over the top of a partition where it abuts the underside of the suspended ceiling. Where sound insulation is important, partitions should, wherever possible, continue through the ceiling to the structural soffit, and be sealed at the perimeter junctions. Gyproc plasterboard suspended ceilings offer better insulation where partitions must stop at ceiling level to provide a continuous plenum. In this instance, a cavity barrier can be incorporated above the ceiling line.

Figures 8 to 11 show the stages of sound insulation improvement for typical ceiling/high performance partition junctions. The best result is achieved by running the partition through to the structural soffit.

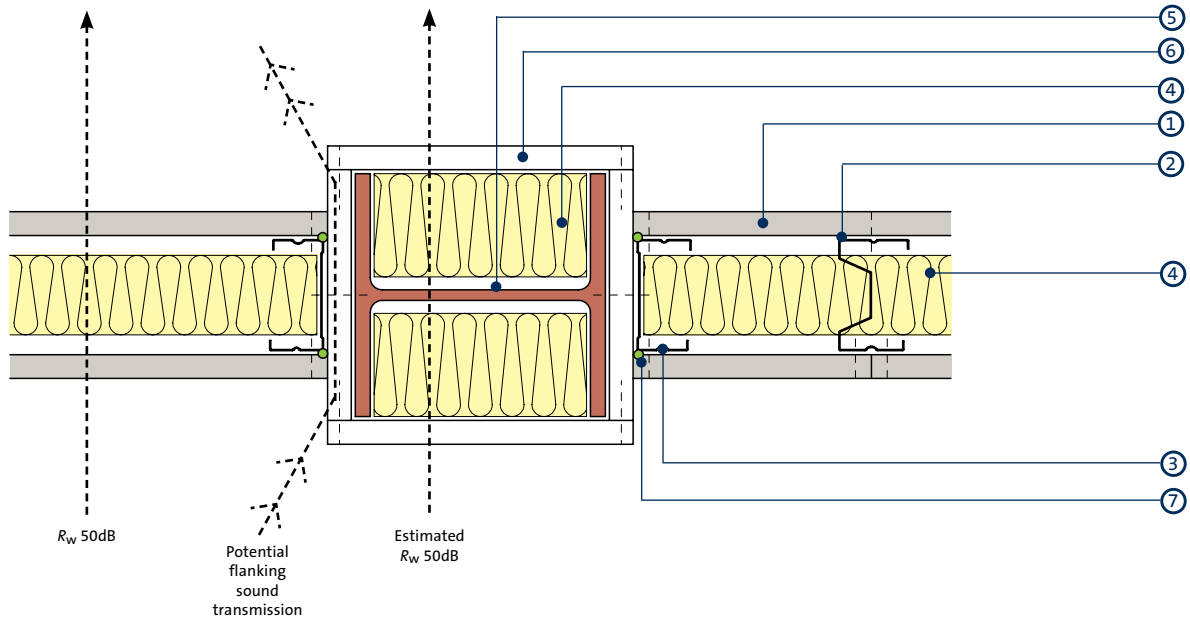
# Technical performance and principles of system design

## Building acoustics (continued)

4



5



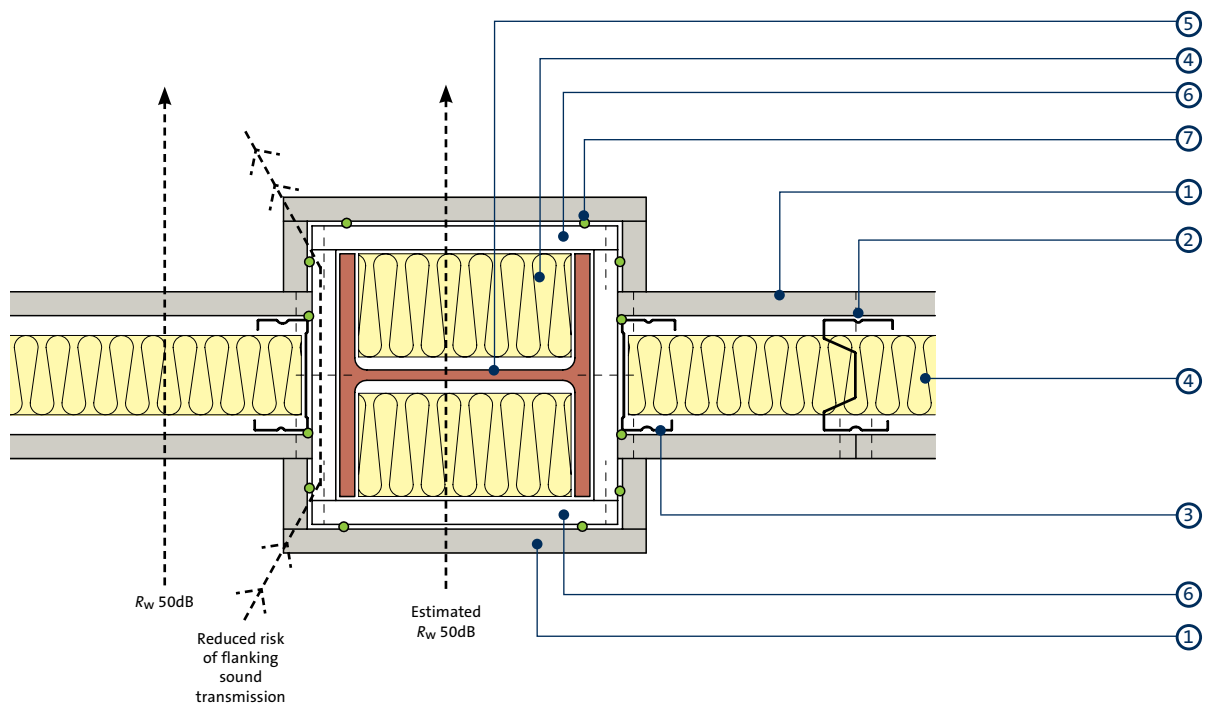
- 1 Gyproc DuraLine
- 2 Gypframe AcouStud
- 3 Gyprock 'C' Stud
- 4 Isover acoustic insulation

- 5 Structural steel
- 6 Glasroc F FIRECASE
- 7 Gyprock Sealant

# Technical performance and principles of system design

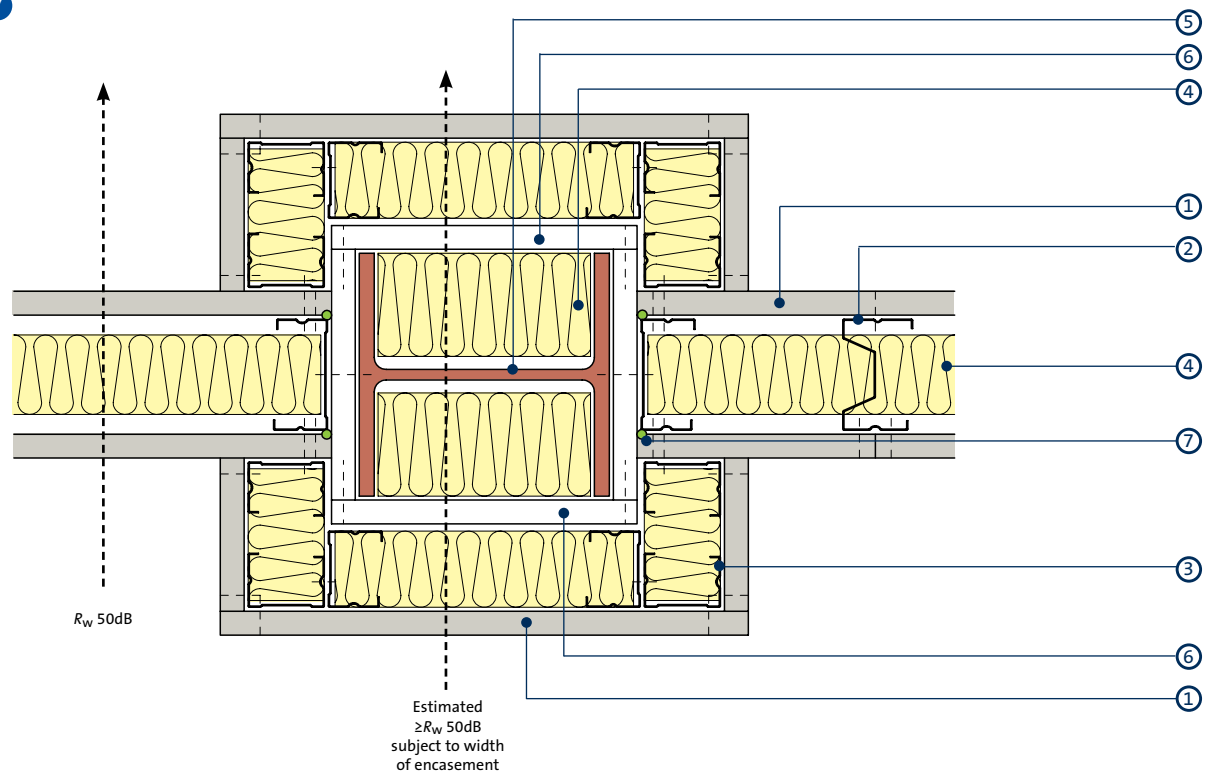
## Building acoustics (continued)

6



Encased steel column with additional plasterboard lining

7



Encased steel column with additional framing, insulation and plasterboard lining

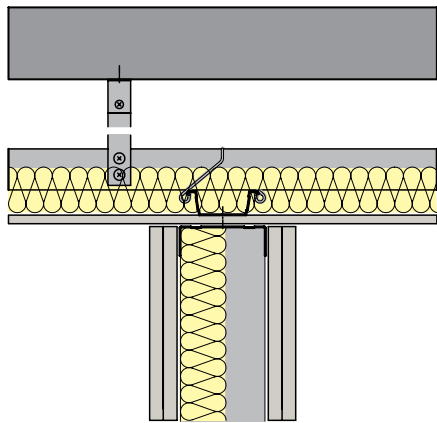
- 1 Gyproc DuraLine
- 2 Gypframe AcouStud
- 3 Gypframe 'C' Stud
- 4 Isover acoustic insulation

- 5 Structural steel
- 6 Glasroc F FIRECASE
- 7 Gyproc Sealant

# Technical performance and principles of system design

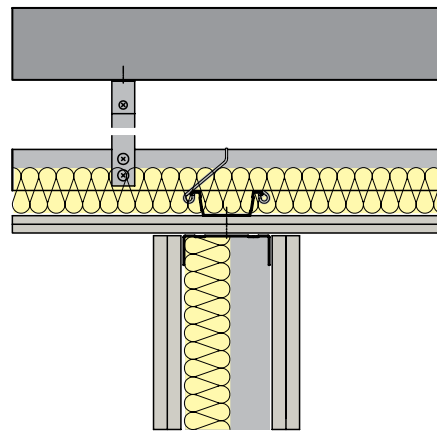
## Building acoustics (continued)

8



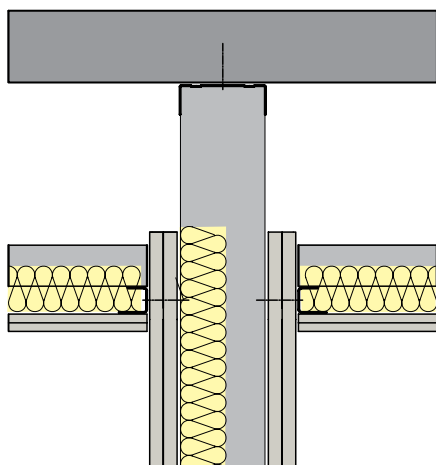
Concealed grid – lined with a single layer of plasterboard and overlaid with insulation = 48dB

9



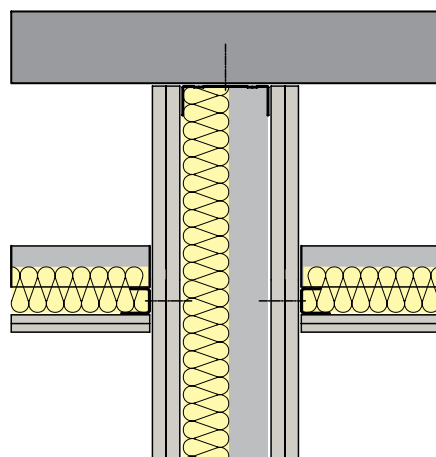
Concealed grid – lined with a double layer of plasterboard and overlaid with insulation = 49dB

10



Concealed grid lined with a double layer of plasterboard within each room and overlaid with insulation = 56dB

11



Partition lining continued to the soffit enabling the full potential of the partition to be achieved = 58dB

# Technical performance and principles of system design

## Building acoustics (continued)

### Composite construction

A common mistake made when designing a building is to specify a high performance element and then incorporate a lower performing element within it; for example, a door within a partition.

Where the difference between insulation is relatively small (7dB or less), there needs to be a comparatively large area of the lower insulation element before the overall sound insulation is significantly affected. However, where there is a greater difference in sound insulation performance between the two elements, this would normally result in a greater reduction of overall sound insulation performance.

Table 1 shows the acoustic effect various door types have within a partition system. For example; if a poor performance door is included within a partition, it does not matter if the wall achieves 35dB or 50dB sound insulation, as the net performance will never be greater than 27dB. The lowest performing element will always dominate the overall performance.

**Table 1 – The effect various door types have within a partition system**

Door construction	Mean sound insulation of partition alone (dB)					
	25	30	35	40	45	50
	Mean sound insulation of partition with doorways accounting for 7% of area (dB)					
Poor performance door with large gaps around the edge	23	25	27	27	27	27
Light door with edge sealing	24	28	30	32	32	32
Heavy door with edge sealing	25	29	33	35	37	37
Double doors with a sound lock	25	30	35	40	44	49

### Acoustic privacy

Two main factors affect the level of acoustic privacy achieved when designing a building:

- The sound insulation performance of the structure separating the two spaces
- The ambient background noise present within the receiving room

The ambient background noise level can be a useful tool when designing buildings, as it is possible to mask speech from an adjacent space and hence provide enhanced speech confidentiality, for example a Doctor's consultancy room next to a waiting room. There are a number of commercially available systems to achieve this. It is, however, more common to treat the problem by specifying appropriate levels of sound insulation. A guide to sound insulation levels is given in table 2.

**Table 2 – Guide to sound insulation levels for speech privacy**

Sound insulation between rooms $R_w$ <sup>1</sup>	Speech privacy
25dB	Normal speech can be overheard
30dB	Loud speech can be heard clearly
35dB	Loud speech can be distinguished under normal conditions
40dB	Loud speech can be heard but not distinguished
45dB	Loud speech can be heard faintly but not distinguished
> 50dB	Loud speech can only be heard with great difficulty

<sup>1</sup> Refer to page 29 for explanations of  $R_w$

For healthcare and educational environments, acoustic privacy issues are covered in more detail within Health Technical Memorandum (HTM) 05 series and TGD 021-5 from the Department of Education

When designing for residential buildings, the standards of sound insulation given in table 2 are not adequate. Reference should be made to the requirements of Technical Guidance Document E (RoI) or Technical Booklet G (NI).

### Ambient noise levels

Along with acoustic privacy, the acceptable level of sound within a room should be assessed. Factors that affect the ambient noise level of a space are:

- The level of external noise
- The level of sound insulation designed into the surrounding structure
- The amount and type of sound absorbing surfaces within the room
- The noise generated by building services

Where control of ambient noise is critical, advice should be sought from an Acoustic Consultant.

For each room there might be a range of levels that are considered acceptable. The designer should select a level appropriate for the particular circumstances.

For this purpose there are a number of methods, including the Noise Rating (NR) system.

The NR system quantifies the level of noise present within a space, taking into account break-in of noise from the adjacent areas, and also the background noise present within the space from ventilation or other building services. Table 3 gives the recommended maximum noise within different activity spaces, using the NR system criteria.

# Technical performance and principles of system design

## Building acoustics (continued)

**Table 3 – Recommended maximum noise rating for various types of room function**

Situation	NR <sup>1</sup> criteria (dB)
Sound studios	15
Concert halls, large theatres, opera houses	20
Large auditoria, large conference rooms, TV studios, hospital wards, private bedrooms, music practice rooms	25
Libraries, hotel rooms, courtrooms, churches, cinemas, medium-sized conference rooms	30
Classrooms, small conference rooms, open-plan offices, restaurants, public rooms, operating theatres, nightclubs	35
Sports halls, swimming pools, cafeteria, large shops circulation areas	40
Workshops, commercial kitchens, factory interiors	45

<sup>1</sup> Refer to 'Ambient noise levels' section on the previous page for explanations of NR.

BS 8233:2014 gives guidance on sound insulation and noise reduction in buildings. The standard includes a matrix that can be used to determine the sound insulation requirement of separating partitions once the noise activity, noise sensitivity and privacy requirements for each room and space are established. An example matrix, which can be adapted according to the specific building use, is given in table 4. Each room may be both a source and a receiving room. Where adjacent rooms have different uses, the worst case sound insulation should be specified.

**Table 4 – Example on-site sound insulation matrix ( $D_{nT,w}$  dB)**

Privacy	Activity noise of source room	Noise sensitivity of receiving rooms		
		Low sensitivity	Medium sensitivity	Sensitive
Confidential	Very high	47	52	57 <sup>2</sup>
	High	47	47	52
	Typical	47	47	47
	Low	42	42	47
Moderate	Very high	47	52	57 <sup>2</sup>
	High	37	42	47
	Typical	37	37	42
	Low	No rating	No rating	37
Not private	Very high	47	52	57 <sup>2</sup>
	High	37	42	47
	Typical	No rating	37	42
	Low	No rating	No rating	37

<sup>2</sup>  $D_{nT,w}$  55dB or greater is difficult to obtain on-site and room adjacencies requiring these levels should be avoided wherever practical. Refer to page 29 for explanations of  $D_{nT,w}$ .

## Sound absorption

Sound absorption is the term given to the loss of sound energy on interaction with a surface. Sound absorbent surfaces are used to provide the correct acoustic environment within a room or space. The choice of material will be influenced by its acoustic efficiency, appearance, durability and fire protection.

By converting some of the sound energy into heat, sound absorbing materials will also help sound insulation because less noise will be transmitted to other rooms. However, this reduction in noise is very small when compared with the potential reduction due to sound insulation. Sound absorption is therefore never a substitute for adequate sound insulation.

## Reverberant energy

Reverberation is the persistence of sound in a particular space after the original sound is removed. A reverberation, or reverb, is created when a sound is produced in an enclosed space causing a large number of echoes to build up and then slowly decay as the sound is absorbed by the walls, ceilings, floor and air. The length of this sound decay is known as reverberation time and can be controlled using sound absorbing materials. The appropriate reverberation time for a space will be dependent on the size and function of the space. Examples of typical reverberation times are given in table 5.

**Table 5 – Typical reverberation times**

Type of room / activity	Reverberation time (mid frequency)
Swimming pool	<2.0 seconds
Dance studio	<1.2 seconds
Large lecture theatre	<1.0 seconds
Small lecture room	<0.8 seconds
Primary school playroom	<0.6 seconds
Classroom for hearing impaired	<0.4 seconds

## Speech clarity

Speech clarity (intelligibility) is now recognised as essential in helping pupils in an educational environment to achieve their full potential.

Research has shown that pupils who cannot understand clearly what the teacher is saying have a tendency to 'switch off' – limiting their own educational opportunities and creating additional stress for teachers. In a typical classroom with the teacher at one end, sound reaches the pupils both directly from the teacher and via reflections from the ceiling, walls and floor. Refer to figure 12.

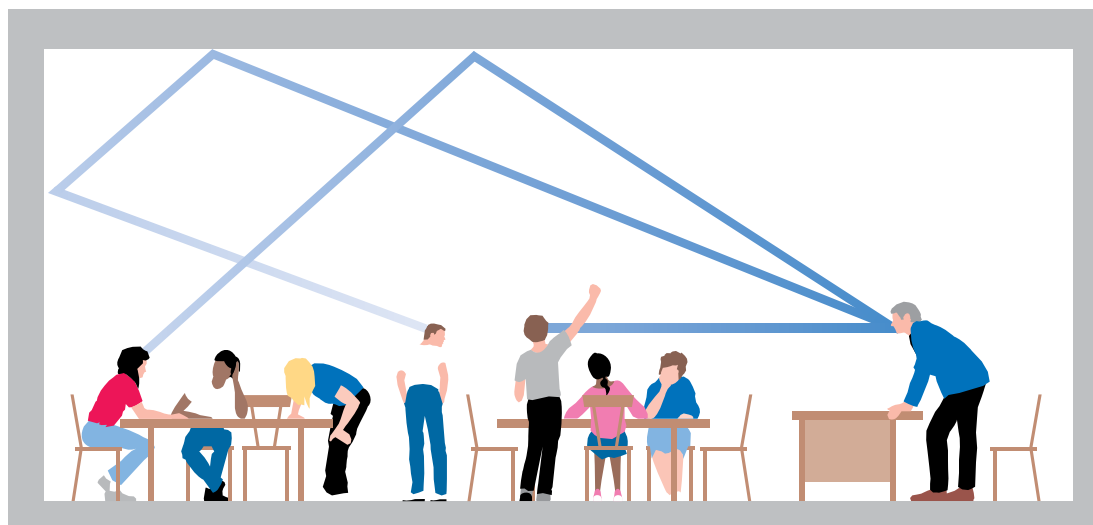
Pupils at the front will generally be able to understand what the teacher is saying, whilst pupils at the back and sides of the room receive a mixture of both direct speech and reflected sound, making it difficult to identify the teacher's words.

Reverberation time alone cannot be relied upon to deliver a suitable environment for good speech intelligibility. In any situation where speech communication is critical, e.g. conference room, lecture theatre or classroom, it is necessary to design the space appropriately using a mixture of sound reflective and sound absorbing surfaces.

# Technical performance and principles of system design

## Building acoustics (continued)

12



Sound transmission in a typical classroom

## Rating methods

### Sound insulation rating methods

The sound insulation rating methods that follow are defined in: *BS EN ISO 717: Part 1: 2013 (airborne)* and *BS EN ISO 717: Part 2: 2013 (impact)*.

#### $R_w$

This single figure rating method is used for laboratory airborne sound insulation tests. The figure indicates the amount of sound energy being stopped by a separating building element when tested in isolation in the absence of any flanking paths.

#### $D_{nT,w}$

This single figure rating method gives the airborne sound insulation performance between two adjacent rooms within a building as measured on site. The result achieved is affected not only by the separating element, but also by the surrounding structure and junction details.

#### $C_{tr}$

The  $C_{tr}$  adaptation term is a correction that can be added to either the  $R_w$  (laboratory) or  $D_{nT,w}$  (site) airborne rating.

The term has been adopted within Building Regulations Technical Booklet G (NI). The  $C_{tr}$  term is used because it targets the low frequency performance of a building element and in particular the performance achieved in the 100 – 315 Hz frequency range. This term was originally developed to describe how a building element would perform if subject to excessive low frequency sound sources, such as traffic and railway noise. Performance tables in

this book present relevant sound insulation values both in  $R_w$  terms but also in the  $C_{tr}$  adapted form. This rating is expressed as  $R_w + C_{tr}$  and allows the Acoustic Consultant to critically compare performances. The rating method mainly considers low frequency performance, and has not been universally welcomed due to the difficulties in measuring low frequency performance.

Consequently, within separating constructions, Gyproc can offer enhanced specifications that meet the low frequency performance of the  $C_{tr}$  rating whilst also offering good mid and high frequency sound insulation.

#### $L_{n,w}$

This single figure rating method is used for laboratory impact sound insulation tests on separating floors. The figure indicates the amount of sound energy being transmitted through the floor tested in isolation, in the absence of any flanking paths. With impact sound insulation, the lower the figure the better the performance.

#### $L'_{nT,w}$

This single figure rating method gives the impact sound insulation performance for floors. The figure indicates the sound insulation performance between two adjacent rooms within a building as measured on site. The result achieved is affected not only by the separating floor but also by the surrounding structure, e.g. flanking walls and associated junction details.

# Technical performance and principles of system design

## Building acoustics (continued)

$D_{n,c,w}$  (as defined in *BS EN ISO 717-1:1997*)

This single figure laboratory rating method is used for evaluating the airborne sound insulation performance of suspended ceilings. Laboratory tests simulate the room-to-room performance of the suspended ceiling when a partition is built up to the underside of the ceiling with sound transmitted via the plenum.

### Sound absorption rating methods

The following ratings are calculated in accordance with *BS EN ISO 11654: 1997*.

#### Sound absorption coefficient, $\alpha_s$

Individual sound absorption figures quoted in one-third octave frequency bands are used within advanced modelling techniques to accurately predict the acoustic characteristics of a space. The coefficient ranges from 0 (total reflection) through to 1 (total absorption).

#### Practical sound absorption coefficient, $\alpha_p$

A convenient octave-based expression of the sound absorption coefficient; commonly used by Acoustic Consultants when performing calculations of reverberation times within a building space.

#### Sound absorption rating, $\alpha_w$

A single figure rating used to describe the performance of a material. The single figure rating can have a modifier added to indicate if the spectral shape is dominated by a particular frequency range

- L – absorption is predominantly in the low frequency region
- M – absorption is predominantly in the mid frequency region
- H – absorption is predominantly in the high frequency region

The absence of a letter following the rating indicates that the absorber has no distinct area of sound absorption and has an essentially flat spectral shape.

### Noise Reduction Coefficient, NRC

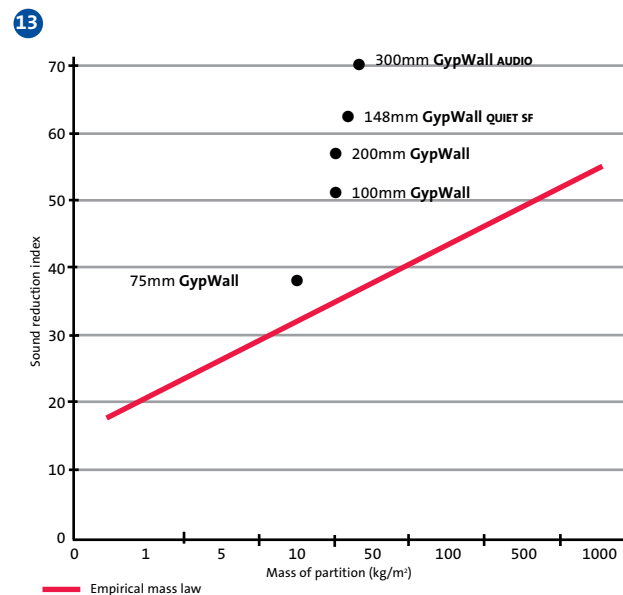
Whilst the sound absorption performance of a ceiling system can be expressed as an NRC, this does not always accurately reflect the product performance. An NRC value is the arithmetic mean of the absorption coefficients across a limited frequency range; this means that it will hide extremes in performance. For instance, a ceiling tile may be a very efficient absorber at high frequencies but very poor at low frequencies, and the NRC value will not reflect this. To optimise the room acoustics the more accurate sound absorption rating,  $\alpha_w$ , should be used.

## Principles of lightweight construction

Typically the average sound insulation of a material forming a solid partition is governed by its mass; the heavier the material, the greater its resistance to sound transmission. To increase the sound insulation of a solid partition by approximately 4dB, the mass must be doubled. This is known as the empirical mass law.

For example; a 100mm solid block wall of average mass 100kg/m<sup>2</sup> will have an approximate  $R_w$  value of 40dB, whereas a 200mm solid wall of the same material would have an  $R_w$  value of 44dB.

Increasing mass is a very inefficient way of achieving sound insulation and one of the advantages of using lightweight cavity partitions and walls is that better than predicted sound reduction values can be achieved. This is why this construction is commonly used in auditoria, e.g. **GypWall AUDIO**. Lightweight systems versus the mass law shows how lightweight systems consistently exceed mass law predictions. This demonstrates that adding mass is not always the best method to satisfy acoustic design requirements and that, lightweight systems, if correctly designed, can provide very effective acoustic solutions. Refer to figure 13.



Lightweight systems versus the mass law

Acoustic performance is commonly expressed as a decibel (dB) value. The logarithmic scale of decibels provides a simple way to cover a large range of values and show them as a convenient number. Unfortunately the decibel scale can create confusion especially when comparing alternative systems as the difference in acoustic performance can appear to be quite small. In reality an increase of 6dB is equivalent to a doubling of the acoustic performance of the system.

# Technical performance and principles of system design

## Building acoustics (continued)

A simple stud partition, for example, can have an  $R_w$  rating of 6dB better than predicted by the mass law. In this case, the maximum sound insulation obtainable will be governed by the transmission of energy through the stud frame. The use of other frame types, or configurations, can result in even better insulation. If Gyproc plasterboard or Gyproc specialist boards are fixed to a timber stud frame using a flexible mounting system, such as Gypframe RB1 Resilient Bar, or a more flexible frame is used, for example, Gypframe studs and channels, sound transmission through the framing is minimised and performance significantly better than the mass law prediction can be achieved.

The use of two completely separate stud frames can produce even better results. In this case, the maximum energy transmission is through the cavity between the plasterboard linings. The air in the cavity can be considered as a spring connecting the linings, which allows the passage of energy. The spring will have some inherent damping, which can be significantly increased by the introduction of a sound absorbing material, such as mineral wool, positioned in the cavity. The increased damping of the air-spring results in a reduced coupling between the plasterboard linings and a consequent decrease in sound transmission. Air-spring coupling becomes less significant as the cavity width increases. In practice, cavities should be as wide as possible to insulate against low frequency sounds.

Two important effects; resonance and coincidence, occur in partitions and walls. These are governed by physical properties such as density, thickness and bending stiffness, and can result in a reduction in sound insulation at certain frequencies.

In lightweight cavity constructions, resonance and coincidence effects can be decreased by the use of two or more board layers. A simple way of increasing the sound insulation performance of a single layer metal stud partition is to add an additional layer of plasterboard to one, or both,

sides. This will increase the sound insulation performance by approximately 6dB or 10dB respectively.

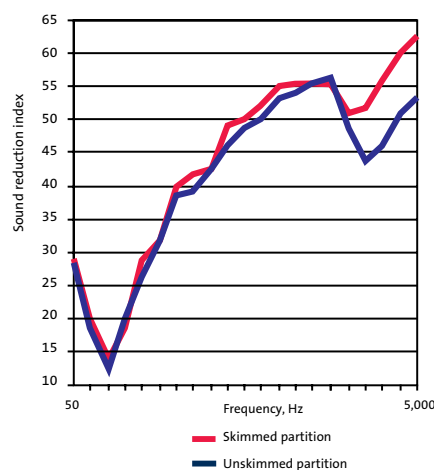
### Acoustic benefits of applying Gyproc Finish Plasters to certain GypWall partition systems

Applying 2mm Gyproc Finish Plasters to both sides of certain GypWall partitions has a positive effect on the sound insulation performance. This is effective on partitions that are limited by their high frequency performance (coincidence region).

The application of Gyproc Finish Plasters also adds mass to the partition which has a positive effect on the mid-frequency of the spectrum.

Figure 14 shows an example of a partition that will be positively affected by skim finish using Gyproc Finish Plasters.

14



Acoustic benefits of applying Gyproc Finish Plasters to certain GypWall partitions

**Table 6 – TGD E: Sound Insulation Requirements (RoI)**

Separating construction	Airborne sound insulation $D_{nT,w}$ dB	Impact sound insulation $L'_{nT,w}$ dB
Walls	53 (min)	-
Floors (including stairs with separating function)	53 (min)	58 (max)

**Table 6a – TB G: Sound Insulation Requirements (NI)**

Separating construction	Airborne sound insulation $D_{nT,w}+C_w$ dB	Impact sound insulation $L'_{nT,w}$ dB
<b>New dwellings</b>		
Walls	43/45 (dwellings only)	-
Floors and stairs	45	62
<b>Dwellings formed by material change of use</b>		
Walls	43	-
Floors and stairs	43	64

# Technical performance and principles of system design

## Building acoustics (continued)

Refer to system sections within 'Partitions' where systems positively affected by the application of Gyproc Finish Plasters are shown. Systems with additional performance will show two acoustic figures in the tables – Sound insulation performance for partitions finished using jointing or plaster skim and sound insulation performance for partitions with a 2mm skim finish of Gyproc Finish Plasters.

## Legislation and guidance

### Building Regulations – Residential Buildings

Building Regulations Technical Guidance Document E (RoI) or Technical Booklet G (NI) gives guidance on how to provide reasonable standards of sound insulation in dwellings and other residential buildings. They cover both new-build and refurbishment or conversion, and include minimum standards of performance.

### Complying with the regulations

In Ireland, housebuilders and residential developers can demonstrate compliance of separating walls and floors for new-build houses and apartments using manufacturers' proprietary systems or Building Regulations Example / Guidance and verifying by Pre-Completion Testing

### Robust Details (Northern Ireland)

To avoid Pre-Completion Testing for new-build houses and flats the Home Builders Federation (HBF) developed a series of Robust Details. These forms of construction have been designed and site tested to ensure that they deliver a standard of sound insulation on site to meet the minimum requirements of TB G. The Building Regulations have been amended to allow Robust Details to be used as an alternative to Pre-Completion Testing.

If you are following the Robust Detail route, you must register each plot, with the details you intend to use, and pay a fee. You will then be given a registration certificate to hand to your building control authority before work starts. Robust Details Ltd administers the scheme.

If you are building to the Irish Green Building Council's Home Quality Rating Tool, Robust Details may entitle you to additional credits under the Health and Wellbeing category – check the Robust Details Handbook for the most up-to-date details.

### Sound Absorption

Section 5.2.2 of TGD E (2014) and Section 7 of TB G (2012) cover reverberation noise in the common internal parts of buildings containing flats or rooms for residential purposes. The regulations state that "the common internal parts of buildings which contain flats or rooms for residential purposes shall be designed and constructed in such a way as to prevent more reverberation around the common parts than is reasonable".

The regulations give two methods of calculating the amount of absorption required in any communal areas. The two methods are referred to as 'Method A' and 'Method B'.

AD E specifies sound absorption in terms of a class of absorber. There are five classes (A through to E) with Class A signifying the products with the highest level of sound absorption. However, to comply with method A, only class C or D is required. The values ascribed to the different classes are given in table 7.

**Table 7 – Absorption class**

Sound absorption class	$\alpha_w$
A	0.90, 0.95, 1.00
B	0.80, 0.85
C	0.60, 0.65, 0.70, 0.75
D	0.30, 0.35, 0.40, 0.45, 0.50, 0.55
E	0.15, 0.20, 0.25
Unclassified	0.00, 0.05, 0.10

For more information, refer to Building Regulations; Section 5.2.2 of TGD E (2014) and Section 7 of TB G (2012): Reverberation in the common internal parts of buildings containing flats or rooms for residential purposes.

### Example constructions

These are constructions developed to repeatedly achieve required design performance levels, if built correctly with correctly designed flanking details. Use of these constructions does not guarantee regulatory performance levels will be achieved, and the onus is therefore on the housebuilder to demonstrate compliance by Post-Completion Testing on site.

### Other constructions

These include manufacturers' proprietary solutions and new, or innovative, constructions not considered to be 'Example Constructions'. Again, the onus is on the housebuilder to demonstrate compliance by Post-Completion Testing.

### Post-Completion Testing

Post-Completion Testing is carried out when the building is complete, with doors, access hatches and windows fitted.

If a test fails due to the construction of the separating floor or associated flanking elements, other untested

# Technical performance and principles of system design

## Building acoustics (continued)

rooms may be affected. This will result in additional testing requirements. It may be prudent to seek specialist advice to identify and remedy any problems.

### Acoustic design of schools

Each room or other space in a school building shall be designed and constructed in such a way that it has the acoustic conditions and the insulation against disturbance by noise appropriate to its intended use.

To satisfy this requirement, it is recommended that buildings comply with the guidance TGD 021-5 Acoustic Performance of Schools from the Department of Education in Rol and Building Bulletin 93 (BB93) Acoustic design of schools, a design guide for Northern Ireland.

BB93 was written by the Department for Children, Schools and Families (DCSF), formerly the Department for Education and Skills (DfES), and provides a regulatory framework for the acoustic design of schools; including sound insulation between spaces, ambient noise levels and optimum reverberation times for various spaces within educational buildings.

For more information refer to our **Education Sector Guide**, available from the Gyproc Technical Department.

### Health and Technical Memorandum HTM 08-01 Acoustics – Healthcare Buildings

Good acoustic design is fundamental to the quality of healthcare buildings. The control of unwanted noise improves patient privacy, dignity and sleep patterns; all key conditions for healing. Good acoustic design also increases the morale and comfort of healthcare professionals.

HTM 08-01 covers the acoustic design criteria that are important for healthcare premises and contains a method of determining the level of sound insulation required between adjacent spaces in a healthcare environment. The document also gives recommended reverberation times for various types of space.

### Hotels and Hospitality: Acoustic Standards

The Fáilte Ireland Guest House Classification Scheme requires that bedrooms, the toilets and bathrooms serving them, and the corridors off which they shall open shall be separated from each other by walls or partitions, floors and ceilings and having an acoustic attenuation of 50 dB.

BS 8233 advises a figure of 43 dB DnT,w + C<sub>tr</sub> (i.e. a site tested result factoring in additional low frequencies) but also 60 dB DnT,w between Bedrooms and other common areas, excluding corridors.

### BS 8233 – Sound insulation and noise reduction for buildings

BS 8233 provides guidance on acoustic ratings appropriate to a variety of different building types. It is applicable to the design of new buildings, or refurbished buildings undergoing a change of use. It deals with control of noise from outside the building, noise from plant and services within it, and room acoustics for non-critical situations.

A full revision of the standard, launched in 2014, includes changes which reflect:

- Legislative framework revision since publication of the 1999 edition
- Revisions to Building Regulations
- The publication of specialist documents for specific sectors, such as healthcare and education
- A reappraisal of the tabular content with respect to setting targets for various classes of living space in the light of research findings
- The need to transfer some of the more detailed information from the main text to annexes
- Requirements for offices

### Designing for on-site performance in Northern Ireland

#### Achieving a $D_{nT,w} + C_{tr}$ performance on site

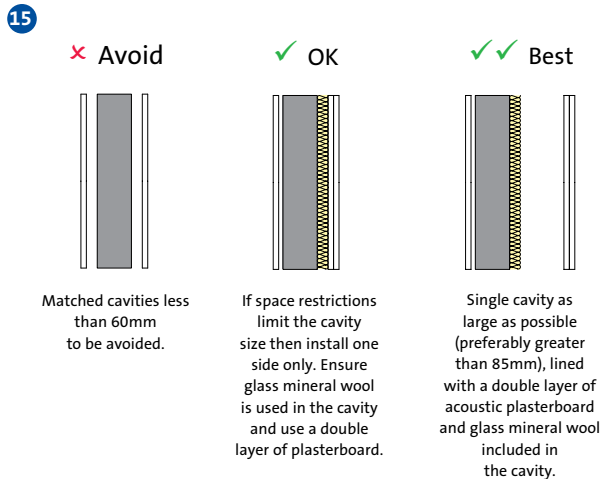
The C<sub>tr</sub> rating method puts increased emphasis on the low frequency region of the spectrum. For lightweight construction this means a significant change in some of the design principles. For partitions, the cavity should be as large as possible and double layers of plasterboard should be used.

For masonry walls lined with lightweight panels, cavities with a depth of less than 60mm should be avoided. Two linings, with small, identical sized cavities either side of a solid masonry wall, should not be specified. These cavities can interact and cause a significant downgrade in the critical low frequency zone. If a small cavity is required, one side only should be lined with a double layer of plasterboard. Optimum performance is achieved by lining one side only and having a cavity depth of at least 85mm.

- ▶ Refer to C02. S01. P41 for more information on service voids.

# Technical performance and principles of system design

## Building acoustics (continued)



Optimum design of panel linings for  $C_{tr}$

To increase the sound insulation of new or existing masonry walls, **Gyplyner** wall lining systems can be used in conjunction with Isover acoustic insulation and Gyproc plasterboard. The cavity depth of the **Gyplyner** lining should be as large as possible, and small, identical sized cavities to either side of the wall should be avoided.

For lightweight separating floors, partially de-coupling the plasterboard ceiling from the floor structure, using Gypframe RB1 Resilient Bars, helps to achieve the required performance. Floating floor treatments, for example timber battens, should have a cavity depth of at least 70mm to avoid low frequency resonance effects in the critical low frequency zone. Performance can be further enhanced by specifying Gyproc Plank within the walking surface.

Floating floor and resilient bar ceiling systems should be tested in a UKAS laboratory to ensure good low frequency performance.

A method of determining the achievable site  $D_{nT,w} + C_{tr}$  performance is to refer to a laboratory  $R_w + C_{tr}$  rating. Depending on the wall specification, a minimum drop of 4dB is typical when comparing  $R_w + C_{tr}$  and  $D_{nT,w} + C_{tr}$ . However, we recommend that a safety margin of + 9dB should be used to reduce the risk of failure to comply with Building Regulations. This assumes all flanking paths are appropriately detailed, ideal site lay-out exists and a high quality of workmanship is applied. For purpose-built dwelling houses and flats requiring  $D_{nT,w} + C_{tr}$  45dB for separating walls, separating floors and stairs, we recommend specifications capable of achieving  $R_w + C_{tr}$  54dB.

For purpose-built rooms for residential purposes requiring  $D_{nT,w} + C_{tr}$  43dB for separating walls, and  $D_{nT,w} + C_{tr}$  45dB for separating floors and stairs, we recommend specifications capable of achieving  $R_w + C_{tr}$  52dB for separating walls, and  $R_w + C_{tr}$  54dB for separating floors and stairs.

For dwelling houses, flats and rooms for residential purposes formed by material change of use requiring  $D_{nT,w} + C_{tr}$  43dB for separating walls, separating floors and stairs, we recommend the use of specifications that are capable of achieving  $R_w + C_{tr}$  52dB.

### Achieving a $D_{nT,w}$ performance on site

Similar to the principles of achieving a  $D_{nT,w} + C_{tr}$  performance on site, a realistic safety margin should be incorporated when designing to meet a  $D_{nT,w}$  requirement, to reduce the risk of failure. We recommend a safety margin of + 7dB when comparing site performance,  $D_{nT,w}$  to laboratory performance,  $R_w$ .

For example, to comply with Scottish Technical Handbook Section 5 in Scotland for a requirement of  $D_{nT,w}$  56dB, a system capable of achieving  $R_w$  63dB under laboratory conditions should be specified.

### Achieving a $L'_{nT,w}$ performance on site

A minimum reduction of 5dB is typical when comparing site performance,  $L'_{nT,w}$  to laboratory performance,  $L_{n,w}$ . However, when designing separating floors to reduce the risk of impact sound flanking transmission, in particular timber joist, the walking surface should be de-coupled from the joists, for example using **GypFloor SILENT** or a batten floating floor system. This is in addition to the de-coupling of the ceiling, using **CasoLine MF** ceiling or Gypframe RB1 Resilient Bar, for example.

Therefore, in some cases the safety margin in the laboratory for timber joist separating floors is likely to be in the region of + 10dB, rather than the typical minimum + 5dB for concrete floors.

The key points for consideration when designing to meet any acoustic performance requirement are below:

- Inappropriate detailing of flanking conditions can greatly reduce the level of performance of the system from that achieved in the laboratory. Refer to figures 4-7 for more information
- For separating wall and floor constructions to be fully effective, care must be taken to correctly detail the junctions between the separating wall or floor and associated elements such as external walls, other separating elements and penetrations or door openings, etc.
- If junctions are incorrectly detailed then the acoustic performance will be limited and Building Regulations requirements will not be achieved in practice
- Pre-Completion Testing exposes poor flanking details and inadequate separating wall and floor specifications. Good flanking detailing and specifications that provide a reasonable margin of safety on site are therefore essential.

# Technical performance and principles of system design

## Building acoustics (continued)

### Examples of practical solutions

#### Gypframe AcouStuds

Gypframe AcouStuds are metal stud sections optimised to give enhanced sound insulation performance. These unique shaped studs are used for increased acoustic performance. Gypframe AcouStuds can be used to upgrade the acoustic performance of 70mm, 92mm and 146mm wall systems.

Figure 16 shows the performance improvement possible using acoustic stud technology compared with a standard 'C' stud of the same cavity dimension.

#### GypWall STAGGERED

GypWall STAGGERED features staggered studs that are located within a head and base channel by means of retaining clips. This arrangement means there is limited connection through the framework to the plasterboard face on the opposite side of the partition. The system design enables a higher level of sound insulation to be achieved with modest cavity sizes.

Figure 17 shows the improvements possible using a staggered stud arrangement compared to a standard GypWall 'C' stud partition with the same partition cavity size.

#### GypWall QUIET SF

GypWall QUIET SF utilises Gypframe RB1 Resilient Bars to partially de-couple the plasterboard linings from the partition stud frame, leading to enhanced levels of sound insulation.

Figure 18 shows the improvements possible when including Gypframe RB1 Resilient Bar on one or both sides of a standard Gypframe 70mm 'C' Stud partition.

#### GypWall AUDIO and GypWall QUIET IWL

The most acoustically effective wall designs are twin frame walls. Minimal or no bridging between the plasterboard linings and the increased cavity size allows optimum performance from the wall.

Figure 19 shows the difference achievable by using a twin framed wall approach as opposed to a standard GypWall 'C' stud partition. The plasterboard linings and insulation are the same for both partitions and the key difference is the overall partition thickness – typically 211mm for the standard partition and 300mm for the twin framed option. With this type of design, further improvements in performance can be achieved by increasing the cavity size and/or increasing the board specification.

#### Gypframe RB1 Resilient Bar (ceilings)

Gypframe RB1 Resilient Bar is an engineered metal component used predominantly with lightweight separating floors to de-couple the ceiling from the floor structure and thereby improve the airborne sound insulation performance of the separating floor.

The value of this component is recognised in Robust Details, where all lightweight floor solutions feature resilient bars to partially de-couple the ceiling from the floor structure.

Figure 20 shows the substantial performance improvements achievable for airborne sound insulation when Gypframe RB1 Resilient Bar is utilised instead of a directly fixed ceiling.

#### Floating floor treatment

Floating floor treatments are used with both lightweight and concrete separating floors to de-couple the walking surface from the floor structure and thereby improve both the airborne and impact sound insulation performance of a separating floor.

The value of this technique is recognised in Robust Details, and is currently featured in a number of separating floor solutions.

#### Sound insulating dry linings

In designing for sound insulation, care should be taken to ensure that flanking transmission via the associated structure does not downgrade the performance of the partition or wall to a level below that required in use. This applies especially when a lightweight partition or wall is constructed in a masonry building. Care should therefore be taken to ensure the associated structure is able to achieve the level of sound insulation required.

The performance of sound resisting floors of timber joist or lightweight concrete construction, supported on or flanked by conventionally finished masonry walls, can be adversely affected by flanking transmission in the walls. This effect can be significantly reduced by the application of a Gyplyner wall lining system, to the flanking walls.

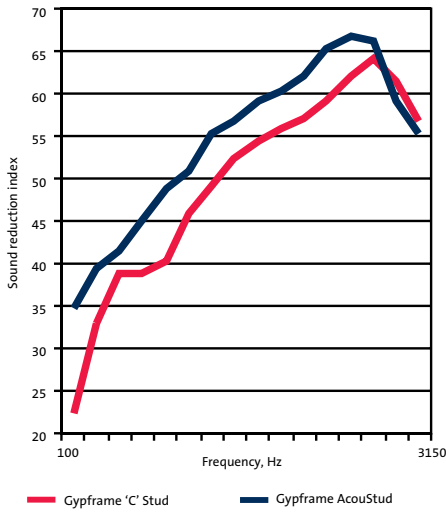
Lining treatments can also be beneficial in refurbishment work when applied to flanking walls of new or existing sound resisting walls.

► Refer to C07. S01. P429 – Linings introduction.

# Technical performance and principles of system design

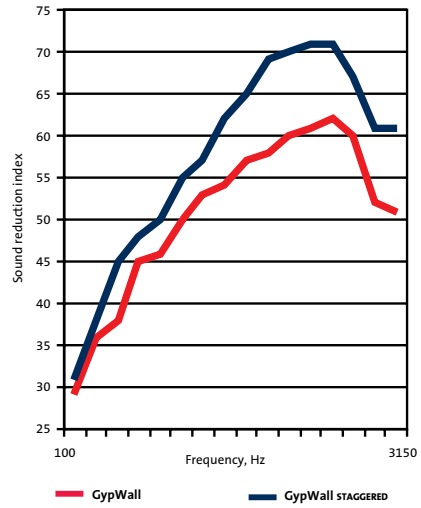
## Building acoustics (continued)

16



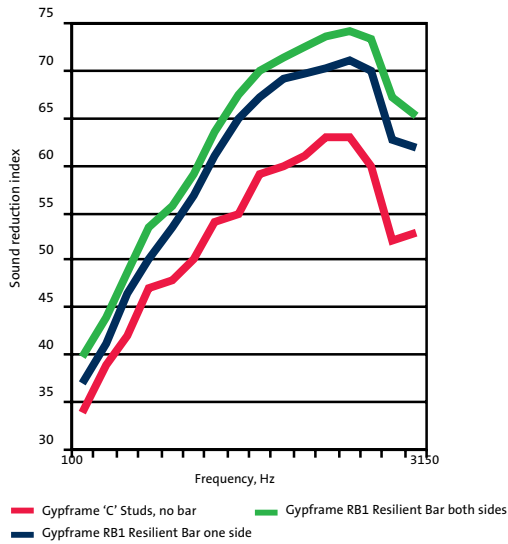
Acoustic benefits of Gypframe AcouStuds

17



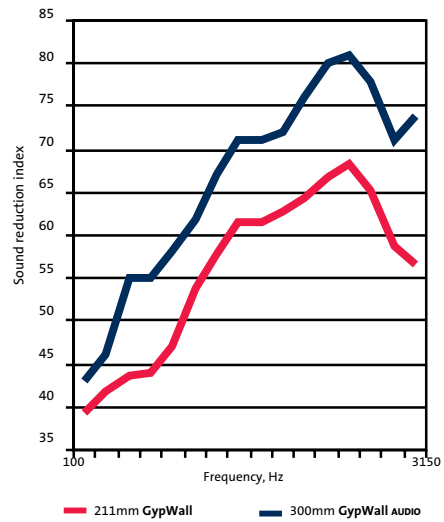
Acoustic benefits of staggered studs

18



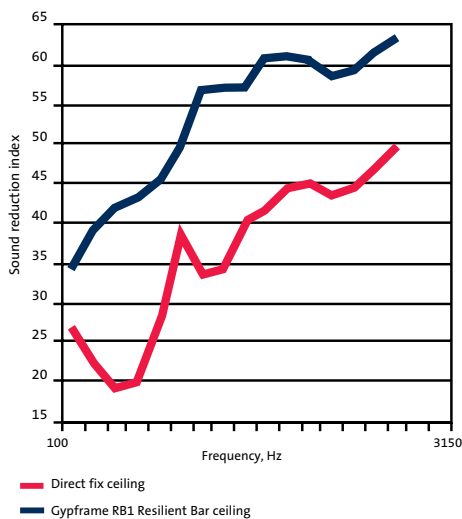
Acoustic benefits of resilient bars (partition)

19



Acoustic benefits of twin stud framework

20



Airborne sound insulation benefit of resilient bars (ceiling)

# Technical performance and principles of system design

## Robustness

### Legislation and guidance

#### **BS 5234: 1992 – Partition (including matching linings)**

BS 5234 comprises two parts – *Part 1 code of practice for the design and installation*, and *Part 2 Specification for performance requirements for strength and robustness including methods of test* in relation to end-use categories. The standard covers performance aspects such as stiffness, crowd pressure, impact resistance, anchorages and door slamming resistance.

#### **BS 6399-1: Part 1:1996 – Loading for buildings: – Code of practice for dead and imposed loads**

This code of practice gives dead and minimum recommended imposed loads for use in designing buildings. Whilst our GypWall partition systems are non-loadbearing, they are able to provide resistance to levels of horizontal uniformly distributed loads (UDL) applied at a height of 1.1m as detailed within this standard for parapets, barriers and balustrades, etc. Refer to examples in table 8.

#### **BS EN 13964: 2014 – Suspended ceiling – Requirements and test methods**

Includes performance requirements for ceiling tiles and suspended ceiling grid systems (concealed and exposed). The standard covers issues such as the load span performance of grids.

### Principles of robust design

#### **Partition Duty Ratings**

All our partition systems have a Duty Rating established in accordance with all the full requirements of BS 5234. This rating relates to the strength and robustness characteristics of the partition system against specific end-use applications. Table 9 gives details of the four duty categories.

A series of tests are used to assess the resistance to damage, both aesthetic and structural, from a range of impacts and load applications.

The tests are conducted at the maximum height for the partition system. BS 5234 itself does not have a method for establishing an acceptable maximum height, and the partition height must be established using a separate method. It is suggested within BS 5234 that the crowd pressure test may be suitable for evaluating heights up to 4200mm, but we would strongly advise against using this inconsistent approach and would never rely solely on BS 5234 for evaluating heights, especially above 4200mm.

**Table 8 – BS 6399-1 – Loading for buildings: – Code of practice for dead and imposed loads**

Gyproc GypWall partitions comprising double layer 12.5mm Gyproc plasterboard or specialist board each side						
Gypframe AcouStuds at 600mm centres	146 AS 50	146 AS 50	92 AS 50	92 AS 50	70 AS 50	70 AS 50
Gypframe Deep Flange Floor & Ceiling Channel	148 EDC 80	148 EDC 80	94 EDC 70	94 EDC 70	72 EDC 80	72 EDC 80
Partition height	7.8m	6m	5.8m	4.9m	4.7m	3.1m
Maximum horizontal UDL as per BS 6399-1, applied at a height of 1.1m	1.5 kN/m	3 kN/m	0.74 kN/m	1.5 kN/m	0.74 kN/m	1.5 kN/m

**Table 9 – BS 5234 Duty Ratings**

Partition Duty Rating	Category	Examples
Light	Adjacent space only accessible to persons with high incentive to exercise care. Small chance of accident occurring or misuse.	Domestic accommodation
Medium	Adjacent space moderately used, primarily by persons with some incentive to exercise care. Some chance of accident occurring or misuse.	Office accommodation
Heavy	Adjacent space frequently used by the public and others with little incentive to exercise care. Chance of accident occurring or misuse.	Public circulation areas, industrial areas
Severe	Adjacent space intensively used by the public and others with little incentive to exercise care. Prone to vandalism and abnormally rough use.	Major circulation areas, heavy industrial areas

# Technical performance and principles of system design

## Robustness (continued)

Tests within BS 5234 include:

- Partition stiffness
- Resistance to damage from a small hard body impactor
- Resistance to damage from a large soft body impactor
- Resistance to perforation from a small hard body impactor
- Resistance to structural damage from a large soft body impactor
- Resistance to damage from door slamming

BS 5234 does not identify specific points of contact on a partition that should be impacted. However, we understand that there are limiting points in terms of impact resistance. These are then subjected to the impact tests to ensure that the most onerous situation is assessed.

Optional tests are also detailed within the standard, but these are not used in the partition grading. These include:

- Resistance to damage from a crowd pressure load
- Lightweight anchorages pull down
- Lightweight anchorages pull out
- Heavyweight anchorages wall cupboard
- Heavyweight anchorages wash basin

► Refer to Service installations within this section, for more information on fixing to drywall systems.

### Important design considerations

To achieve Heavy Duty Rating or Severe Duty Rating, the door detail needs to be reinforced otherwise the door opening will undergo too much deflection and damage during the onerous door slamming test.



### Important information

To claim a partition Duty Rating, all tests must achieve the designated performance level. It is not possible, for example, for a partition lined with a single layer of Gyproc WallBoard (12.5mm) to achieve a Duty Rating better than medium, because of the board's performance in the hard body perforation test. In the majority of cases, the type of board used will determine the maximum partition Duty Rating. Table 10 shows the maximum rating available based on a single layer board lining. In all cases, a double layer lining achieves Severe Duty Rating.

**Table 10 – Board type required to achieve a given Duty Rating (single layer) solutions**

Board type	Maximum rating
Gyproc WallBoard 12.5mm	Medium
Gyproc WallBoard 15mm	Medium
Gyproc SoundBloc 12.5mm	Medium
Gyproc SoundBloc 15mm	Medium
Gyproc FireLine 12.5mm	Medium
Glasroc H TILEBACKER 12.5mm	Medium
Gyproc FireLine 15mm	Heavy
Gyproc SoundBloc 15mm	Heavy <sup>1</sup>
Glasroc F MULTIBOARD 10mm	Heavy
Gyproc Habito 12.5mm	Severe
Glasroc F MULTIBOARD 12.5mm	Severe
Gyproc DuraLine 15mm	Severe
Rigidur 12.5mm / 15mm	Severe

<sup>1</sup> Minimum Gypframe 70mm Stud for Heavy Duty Rating.

The level of deflection and strength performance required to achieve Light Duty Rating within BS 5234 is, in our opinion, unsuitable for any application. We do not offer any systems with a rating less than Medium Duty Rating.

### Maximum partition heights

As stated previously, BS 5234: Part 2 does not contain a consistent methodology for establishing the performance of a partition in terms of height. To date the UK and Ireland has adopted a methodology, which is based on the level of lateral deflection under a given uniformly distributed load (UDL). The criterion is that the maximum lateral deflection of the partition should not exceed L/240 (where L is the partition height) when the partition is uniformly loaded to 200Pa.

We utilise a UKAS accredited test laboratory to evaluate partition system heights against this performance criteria. The test evidence comes from a full-scale test procedure where the test specimen is subjected to a UDL and the induced lateral deflection recorded. From this procedure, it is possible to establish the maximum height for a range of partition systems.

When cutting Gypframe studs to suit the partition height, it is not good practice to cut the stud through the location of a service cut-out.

# Technical performance and principles of system design

## Robustness (continued)

### Assessing acoustic performance of GypWall with reduced stud centres

Reducing the centres of the metal studs within GypWall partition systems can have a detrimental effect on the sound insulation performance of the system. We have estimated the performance reductions for GypWall:

- When there is no insulation within the partition cavity and studs are closed down to 400mm centres, this results in an estimated 2dB loss in  $R_w$  compared to studs at 600mm centres with no insulation
- When there is no insulation within the partition cavity and studs are closed down to 300mm centres, this results in an estimated 3dB loss in  $R_w$  compared to studs at 600mm centres with no insulation
- When there is a minimum 25mm Isover Acoustic Roll within the partition cavity and studs are closed down to 400mm centres, this results in no loss in  $R_w$  compared to studs at 600mm centres with 25mm Isover Acoustic Roll
- When there is a minimum 25mm Isover Acoustic Roll within the partition cavity and studs are closed down to 300mm centres, this results in an estimated 2dB loss in  $R_w$  compared to studs at 600mm centres with 25mm Isover Acoustic Roll

Where Gyproc Finish Plasters are specified to obtain a 1 or 2 dB uplift, this will be negated when closing down stud centres or changing stud profile.

If the partition system is also performing a fire compartmentation function to EN standards, the partition height in the fire state also needs to be established for the required duration. It should not be assumed that the cold state height is still valid in the fire state.

### Movement

Deflection of upper floor and roof slabs can cause appreciable stress in partitions. Where such deflection is likely to occur, the partition to structural soffit junction detail must be designed to accommodate movement, whilst still complying with any fire or acoustic performance requirements. Typical deflection head details for fire-rated GypWall partition systems are given in the relevant partition and wall system sections within this book. Additional attention to detailing will be required to optimise sound insulation performance. The detail included in GypWall **STAGGERED** shows a good practice solution incorporating steel angles, either side of the head and sealed to the structure. Refer to figures 2 and 3 earlier in this section for more information.

Where linings (partitions, wall linings and ceilings) cross a movement joint in a structural wall, floor or roof slab, they should be provided with a movement joint at the same point, and be capable of the same range of movement

as the wall, floor or roof joint. Gyproc Control Joint provides a suitable solution for movement up to 7mm. Gyproc Control Joint may also be required to relieve stresses induced by extreme environmental conditions. For example, consideration could be given to installing control joints at 10m centres in linings that are subjected to either extreme or variable temperatures.

► Refer to C07. S05. P477 detail 7 and 8 – Control joint detail.

### Environmental conditions

#### Temperature

Gyproc plasterboards, Glasroc F specialist boards and Gyproc plasters should not be used where the temperature will exceed 49°C. Prolonged exposure to high temperature, and/or multiple exposure for short periods, results in the gradual continued calcination of the gypsum and loss of its inherent properties. Gyproc plasterboards, Glasroc F specialist boards and Gyproc plasters (once fully dried) can be subjected to freezing conditions without risk of damage.

#### Moisture

Our products should not be used in continuously damp conditions or in buildings that are not weather tight. However, our Gyproc moisture resistant grade plasterboards and Glasroc F specialist boards are suitable for use in intermittently damp conditions or sheltered external situations in conjunction with an appropriate decorative finish. This should take the form of ceramic tiling or other suitable moisture impervious coating by others. Glasroc H TILEBACKER can be used as a tiling substrate in high moisture applications.

#### Relative humidity (RH)

In moderate humidity situations, i.e. 40% to 70% RH, no special precautions need to be taken when using Gyproc plasterboards, other than those necessary to prevent interstitial condensation. However, whenever the building's heating system is turned off a rapid increase in the relative humidity can occur as the building cools down. This could lead to the occurrence of potentially harmful surface condensation. Precautions to avoid this problem should be taken, e.g. by continuing to run the ventilation system after the heating is turned off.

Low humidity does not affect the plasterboards, but may lead to distortion of timber framing members as they dry to below their usual moisture content. Intermittently high relative humidity, i.e. above 70% RH, requires special treatment to the face of the plasterboards, and only moisture resistant grade plasterboards or Glasroc F specialist boards should be used. Suitable surface treatments include ceramic tiling and water vapour resistant paint systems. Gyproc plasterboards are not considered suitable in continuously high humidity conditions. Certain Gyproc ceiling products are suitable for use in environments above 70% RH.

# Technical performance and principles of system design

## Robustness (continued)

### Special environments – swimming pools and similar environments

#### Ceiling lining

Our products and systems are regularly specified for ceilings in and around swimming pool halls and similar areas. With regard to ceiling specifications attention to detail is critical. The following guidance should be considered:

- The boards to be used should be moisture resistant grade or Glasroc F specialist boards. They should be screw-fixed to a framed system at their recommended centres
- The surface of the board should be finished using our recommended methods, and they must be set and dry before applying decoration. Gyproc Finish Plasters are not recommended for this type of environment
- The decoration should take the form of a suitable moisture impervious finish supplied by other manufacturers
- Penetrations in the ceiling linings and perimeters should be avoided where possible. All service penetrations must be sealed using a moisture resistant sealant (even though the recommended plasterboards are moisture resistant it is unwise to allow moisture to gain access to the core of the board)
- The air in the pool area should be conditioned such that condensation will not form on the surface of the boards
- In situations where there is a risk of condensation occurring within the ceiling cavity, it must be mechanically ventilated or the decorative finish must be impervious to water vapour. This will minimise the risk of condensation forming on 'cold' surfaces in the cavity, which could then come in to contact with the unprotected back face of the plasterboard lining
- It is good practice to protect the cut ends of Gypframe metal components using suitable material to prevent corrosion
- Ensure that the Gypframe metal frame is totally encapsulated by suitable Gyproc board and waterproof finishing system (by others).

#### Wall lining

Offering enhanced levels of moisture resistance performance, Glasroc H TILEBACKER is suitable as a tiling substrate in high moisture environments including domestic shower enclosures and bathrooms, commercial kitchens and changing areas.

Gyproc moisture resistant grade boards and Glasroc F specialist boards are not suitable to be used in those areas, but can be considered for use in adjacent areas of wall lining and in most domestic situations. Attention to detail is critical and, in addition to the guidance given above for ceiling linings, the following additional guidance should be considered:

- The lining boards must be lifted clear from any floor where free water is possible and a suitable skirting detail must be employed which will not allow water penetration
- In extreme moisture environments, Glasroc H TILEBACKER must be used in conjunction with a tanking system
- Important guidance is given within *BS 5385-1: 2009* and *BS 5385-4: 2009*, within which gypsum plasterboard and gypsum plaster are deemed unsuitable backgrounds for tiling in 'frequently wetted' areas. These areas include communal showers and pool halls

#### Ceilings

*EN 13964: 2014* includes class definition relating to exposure conditions and maximum deflection. The standard **CasoLine MF** ceiling layout is capable of complying with deflection Class 2 and exposure Class A, however the system can be modified to meet Classes 1 and B. Contact the Gyproc Technical Department for further guidance.

# Technical performance and principles of system design

## Service installations

### Service installations

#### Services within partitions and lining cavities

The installation of electrical services must always be carried out strictly in accordance with the National Rules for Electrical Installations, Fourth Edition ET101:2008 (RoI) and *BS 7671 Requirements for electrical installations. IET Wiring Regulations (NI)*.

Services can be incorporated within all our partition and lining systems. As shown in figure 21 and figure 22, Gypframe studs either have cut-outs or push-outs to accommodate routing of electrical services and other small services. Grommets or isolating strips should be installed in the cut-out to prevent abrasion of the cables.

Gypframe channels do not generally have cut-outs and so, if required, they need to be cut on-site, paying attention to Health & Safety guidance. Grommets or isolating strips should be installed in these cut-outs to prevent abrasion of the cables. However, Gypframe GWR3 Floor & Ceiling Channel has half-round cut-outs at regular centres. Refer to figure 23. These cut-outs are designed to prevent abrasion of electrical cables where they pass through the metal framework, therefore grommets are not required.

When installing electrical services within a partition, this might result in the concealed cable being less than 50mm from the surface of the partition, particularly if the partition is less than 100mm thick. Whilst it may be apparent that electrical services are contained within a partition cavity due to the appearance of electrical sockets / switches on the partition surface, this might not be obvious from the reverse side. Therefore, before carrying out work, e.g. drilling into the surface, the reverse side of the partition must always be checked to determine the location of any concealed cables. It is good practice to maintain a clear zone. Where the location of electrical outlets cannot be determined from the reverse side, then the cable must either be mechanically protected or run at least 50mm from the surface of the wall or partition on the reverse side. Refer to figure 24 and figure 25.

Where heating pipes, particularly micro-bore systems, are to be located within the **GypWall** system, it is recommended that only one pipe is passed through each aperture in the metal framework. If this cannot be accommodated for whatever reason, it may be necessary to incorporate proprietary pipe restraining clips, or other means of keeping the pipes apart, to prevent vibration noise.

If a lining system, such as **Drilyner**, does not have sufficient depth to accommodate the service then the background should be 'chased out' to the appropriate depth considering maximum allowable tolerances. Pipes or conduits should be fixed in position before work commences.

Please see National Housing Building Council (NHBC) Standards 8.1 and Building Research Establishment (BRE) Thermal Insulation: avoiding risks (BR262)'.  
*Thermal insulation covering or around cables has the effect of reducing the current carrying capacity and so the cable may need to be de-rated and increased in size.*

Thermal insulation covering or around cables has the effect of reducing the current carrying capacity and so the cable may need to be de-rated and increased in size.

► Refer to National Rules for Electrical Installations, Fourth Edition ET101:2008, BS 7671 and SR 54: Code of Practice: Methodology for the energy efficient retrofit of existing dwellings.

To maintain an airtight construction, the perimeter of any penetration through the lining should be sealed as necessary at the time the services are being installed.

Hot and cold water pipes should be installed strictly in accordance with manufacturers instruction.

In the case of gas service pipes behind drylined walls, *BS 6891* states that the pipe should be encased in building material, which could take the form of Gyproc plaster. Alternatively, apply a continuous band of Gyproc Plasterboard Compound or timber battens either side of the pipe to receive a plasterboard lining.

#### Service penetrations and fixing into drywall systems

Switch boxes and socket outlets can be supported on brackets formed from Gypframe 99FC50 Fixing Channel or cut and bent channels fixed horizontally between the studs. Alternatively, services can be fixed to the face of the partition, using a Gypframe Service Support Plate, which carries 18mm plywood within the cavity of the partition as shown in figure 26.

In fire-rated walls, the fire-stopping design is dependent on the period of fire resistance. Where acoustic performance is not a specific requirement, refer to figure 27 and figure 28.

Fixing electrical socket boxes into our partitions and walls can affect the technical performance e.g. fire, acoustic, air leakage, but careful detailing can minimise this. Robust Details offer specific guidance on the installation of socket boxes in separating walls, particularly with regard to the avoidance of back-to-back services. Refer to figure 29.

There are a number of putty pad products available on the market from a range of manufacturers and whilst we have no objection to the use of putty pads (by others) within drylining systems, all performance substantiation has to be provided by the fire-stopping manufacturer as is the case for any fire-stopping material. Refer to figure 30, for example.

The Robust Details pattern book also offers *the* alternative of a 'sacrificial' lining in front of a separating wall to create a zone for service installation. These service zones remove the need for service penetration of the actual Robust Detail separating wall construction, which in turn removes the

# Technical performance and principles of system design

## Service installations (continued)

risk of a loss in acoustic performance as a result of service penetrations. Refer to figure 31.

This method is increasingly migrating to projects where Pre-Completion Testing is being used, as best practice. However, it can lead to a downgrading of the  $D_{nT,W} + C_{tr}$  performance of the base wall due to the introduction of additional cavities within the overall construction. Robust Detail walls are designed to exceed the building regulations so the slight potential downgrade in performance caused by the 'sacrificial' lining would not lead to system failure.

Where Pre-Completion Testing is required however, depending on the system specified, there may not be this level of 'safety margin', particularly at lower frequencies. Therefore, where additional 'sacrificial' service installation zone linings have been specified in non-Robust Details systems the most appropriate solution to ensure no reduction in the acoustic performance of the base partition is a 70mm cavity with 50mm Isover Acoustic Roll and a single layer 15mm Gyproc SoundBloc board lining installed on one or both sides of the base partition construction. Refer to figure 32, for example.

The plasterboard should always be neatly cut and Gyproc Sealant should be applied where optimum acoustic performance is required.

In wall linings and ceilings, access for services may be required for routine maintenance, inspection, upgrading or repair. This can be achieved by installing Gyproc Proflex Access Panels. Services should be routed through the lowest acoustic performing wall where possible. Penetrations of fire-resistant constructions for services need careful consideration to ensure that the integrity of the element is not impaired, and also that the services themselves do not act as the mechanism for fire spread. It is important to use only those services and their installations that have been shown by a fire test to be able to maintain the integrity of the construction. By designing service zones, through which all services pass, the number of individual service penetrations can be minimised. Service zones can be sealed after installation of the services using a tested and substantiated fire-stopping system.

In most situations, the services will be installed by contractors other than the drylining contractor. It is important, therefore, that all relevant contractors are advised as to where and how their service penetrations should be made and maintained. The necessity to independently support services will depend on their size and weight and the drylining specification.

There is a wide variety of fixing devices suitable for securing fixtures and fittings to our systems. Generally, the choice of individual fixing devices will depend on the type of system and the loading requirements. This section gives recommendations on the selection of generic devices and proprietary fixings. Tables 11, 12 and 13 give example fixing

devices and typical applications in drywall systems to meet the specific load criteria for single fixtures. It is important to ensure that the drylining system specified is capable of supporting the loads, particularly if installing multiple fixtures. Furthermore, it may be necessary to incorporate several fixings per fixture to ensure the weight is distributed across the drylining system rather than a point load, particularly for medium to heavy fixtures.

The guidance given is primarily concerned with fixtures at the time of installation. For subsequent installation, especially for heavier fixtures, the identification of studs and noggings within the lining / partition system will be required in order to attach the fixtures at these points.

### Duct / damper penetration through drywall systems

Fire and smoke resisting dampers can be installed in our systems. Dampers prevent fire and smoke from passing from one fire compartment to another through heating, ventilation and air conditioning systems. 'An Industry Guide to the Design for the Installation of Fire and Smoke Resisting Dampers' is available from the Association of Specialist Fire Protection (ASFP) or as a download from [asfp.org.uk](http://asfp.org.uk). This document refers the designer to the principles of construction, and in particular to tested constructions, or to constructions assessed for performance in fire by a suitably qualified person.


Figure 33, figure 34 and figure 35 show a method of preparing openings for installing dampers up to a maximum weight of 57kg within our systems. As the performance of the complete assembly will depend on a number of elements, the actual details of the opening need to be determined in conjunction with the fire-stopping and damper manufacturers.

# Technical performance and principles of system design

## Service installations (continued)

**Table 11 – Example fixing devices and typical safe working loads on partitions and wall linings**

System	Lightweight fixtures up to 3kg (e.g. socket)	Lightweight to medium fixtures up to 4 – 8kg (e.g. small mirror)	Medium weight fixtures 9 – 20kg (e.g. shelf)	Medium to heavy fixtures 21 – 50kg (e.g. cupboard)	Heavy fixtures 51 – 100kg (e.g. basin)
ShaftWall and GypWall systems <sup>1</sup> GypLyner iwL	A	B or C	D, E or I	G, H or I	K
Timber stud	A	B or C	K or D	K	K
Drilyner	A	B	F	L	L
GypLyner wall lining	A	B or C	D or E	K	K

Reference	Detail	Description	Typical SWL <sup>2</sup> (typical failure load)
A		5mm woodscrew into Gyproc plasterboard	3kg (12kg)
B		Steel picture hook and masonry nail into Gyproc plasterboard	4kg (16kg)
C		Metal self-drive into single layer Gyproc plasterboard	6kg (24kg)
		Metal self-drive into double layer Gyproc plasterboard	8kg (32kg)
D		Steel expanding cavity fixing, e.g. M5 x 40, into Gyproc plasterboard (board thicknesses up to 12.5mm)	12kg (48kg)
		Steel expanding cavity fixing, e.g. M5 x 65, into plasterboard (board thicknesses from 15mm to 28mm)	18kg (72kg)
E		Gyproc Drywall Screw fixed through Gyproc plasterboard into 0.5mm Gypframe metal stud / Gypframe 99 FC 50 Fixing Channel	19kg (76kg)
F		Heavy duty plastic plug fixed through Gyproc plasterboard into masonry with 55mm minimum penetration	20kg (140kg)
G		Gyproc Jack-Point Screws fixed through Gyproc plasterboard into minimum 0.9mm Gypframe metal stud	30kg (120kg)
H		No.12 self-tapping screws fixed through Gyproc plasterboard into minimum 0.9mm Gypframe metal stud	50kg (200kg)
I		Steel expanding metal cavity fixing, e.g. M4 x 40, through Gyproc plasterboard into 0.9mm Gypframe metal stud (board thicknesses up to 12.5mm)	40kg (160kg)
		Steel expanding metal cavity fixing, e.g. M4 x 65, through Gyproc plasterboard into 0.9mm Gypframe metal stud (board thicknesses from 15mm to 28mm)	50kg (200kg)
		Steel expanding metal cavity fixing, e.g. M5 x 65, fixing through Gyproc plasterboard into plywood supported by Gypframe Service Support Plate	50kg (200kg)
J		8mm steel frame fixing fixed through Gyproc plasterboard into masonry with minimum 55mm penetration	60kg (240kg)
K		No.12 self-tapping screw fixed through Gyproc plasterboard into timber sub-frame	120kg (480kg)
L		M8 steel bolt / anchor fixed through Gyproc plasterboard into masonry with minimum 55mm penetration	130kg (520kg)

<sup>1</sup> For GypWall QUIET SF, ensure that the fixings do not bridge the Gypframe RB1 Resilient Bars, otherwise the acoustic performance will be compromised.

<sup>2</sup> Safe Working Load (SWL) – a safety factor of 4 (steel fixings) and 7 (plastic fixings) has been used.

For technical assistance on above fixings please contact the fixings manufacturer. The suitability of the fixing must be confirmed by the building designer / fixing manufacturer.






Reference can also be made to the Construction Fixing Association (CFA) guidance note 'Fixing For Plasterboard', which can be accessed at [fixingscfa.co.uk](http://fixingscfa.co.uk)

The information within table 11 does not take into consideration any additional forces that may be applied whether it be accidental, abusive or otherwise. The example fixing devices, typical safe working loads and typical failure loads given in table 11 relate to the installation of single fixtures. It is important to ensure that the drylining system specified is capable of supporting the loads, particularly if installing multiple fixtures. Furthermore, it may be necessary to incorporate several fixings per fixture to ensure the weight is distributed across the drylining system rather than a point load, particularly for medium to heavy fixtures.

# Technical performance and principles of system design

## Service installations (continued)

**Table 12 – Example fixing devices and typical safe working loads on partitions incorporating Rigidur (GypWall EXTREME)**








Reference	Detail	Description	Typical SWL <sup>1</sup> (typical failure load)
B		Steel picture hook and masonry nail into 12.5mm Rigidur	17kg (68kg)
		Steel picture hook and masonry nail into 15mm Rigidur	18kg (72kg)
F		Fischer PD nylon plug and screw into 12.5mm or 15mm Rigidur	20kg (140kg)
A		No. 10 woodscrew into 12.5mm or 15mm Rigidur	15kg (60kg)
I		Fischer HM8 x 55 steel cavity fixing into 15mm Rigidur	49kg (196kg)
M		Fischer KD6 steel cavity fixing into 12.5mm Rigidur	58kg (232kg)
		Fischer KD6 steel cavity fixing into 15mm Rigidur	74kg (296kg)

<sup>1</sup> Safe Working Load (SWL) – a safety factor of 4 (steel fixings) and 7 (plastic fixings) has been used.

For technical assistance on above fixings please contact the fixings manufacturer. The suitability of the fixing must be confirmed by the building designer / fixing manufacturer.

The information within table 12 does not take into consideration any additional forces that may be applied, whether it be accidental, abusive or otherwise. The example fixing devices, typical safe working loads and typical failure loads given in table 12 relate to the installation of single fixtures. It is important to ensure that the drylining system specified is capable of supporting the loads, particularly if installing multiple fixtures. Furthermore, it may be necessary to incorporate several fixings per fixture to ensure the weight is distributed across the drylining system rather than a point load, particularly for medium to heavy fixtures.

**Table 13 – Example fixing devices and typical safe working loads on partitions incorporating Habito (GypWall SUPERIOR)**

Reference	Detail	Description	Typical SWL <sup>1</sup> (typical failure load)
A		5mm Woodscrew into 12.5mm Gyproc Habito	15kg (60kg)
A		5mm Woodscrew into 2 x 12.5mm Gyproc Habito	34kg (136kg)
N		Steel expanding cavity fixing - M5/12 Cavity Anchor into 12.5mm Gyproc Habito	37kg (148kg)
O		Steel expanding cavity fixing - M5/25 Cavity Anchor into 12.5mm Gyproc Habito	47kg (188kg)
O		Steel expanding cavity fixing - M5/25 Cavity Anchor into 2 x 12.5mm Gyproc Habito	81kg (324kg)
P		M4 Spring Toggle into 12.5mm Gyproc Habito	42kg (168kg)
P		M4 Spring Toggle into 2 x 12.5mm Gyproc Habito	53kg (212kg)

<sup>1</sup> Safe Working Load (SWL) – a safety factor of 4 (steel fixings) has been used.

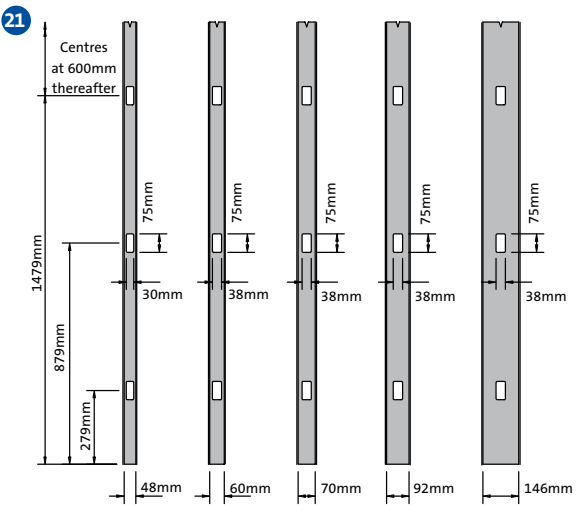
For technical assistance on above fixings please contact the fixings manufacturer. The suitability of the fixing must be confirmed by the building designer / fixing manufacturer.

The information within table 13 does not take into consideration any additional forces that may be applied, whether it be accidental, abusive or otherwise. The example fixing devices, typical safe working loads and typical failure loads given in table 13 relate to the installation of single fixtures. It is important to ensure that the drylining system specified is capable of supporting the loads, particularly if installing multiple fixtures. Furthermore, it may be necessary to incorporate several fixings per fixture to ensure the weight is distributed across the drylining system rather than a point load, particularly for medium to heavy fixtures.

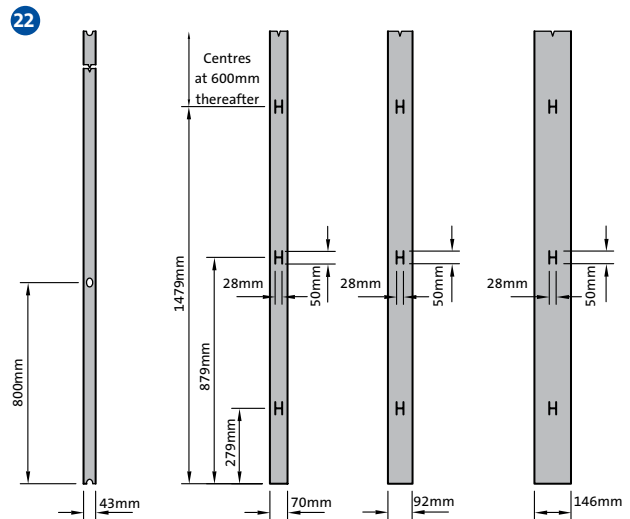
# Technical performance and principles of system design

Service installations (continued)

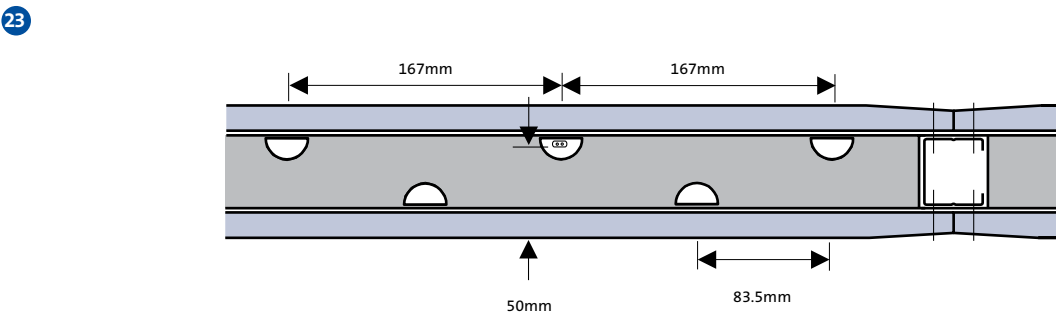
## Figures



Gyframe studs service cut-out details – Gyframe 'C' and Gyframe 'I' Studs



Gyframe studs service push-out details – Gyframe AcouStuds



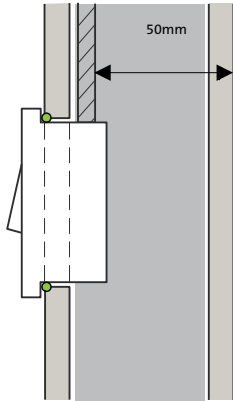
Cross-nogging cut-outs

# Technical performance and principles of system design

Service installations (continued)

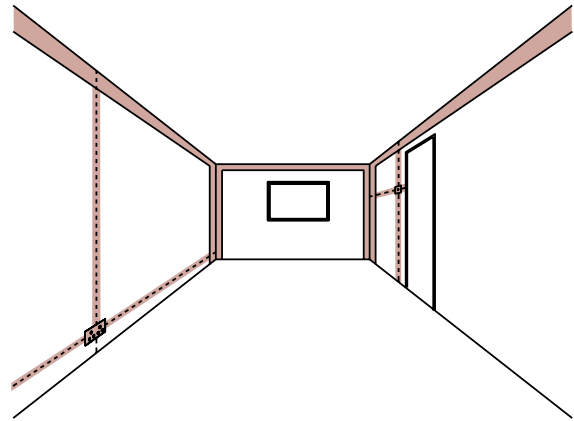
## Figures

24



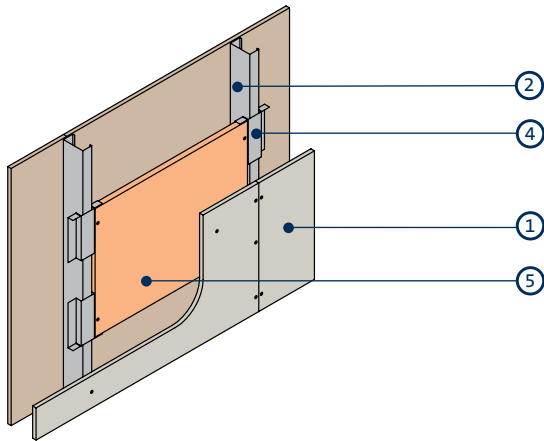
Minimum distance of cabling

25



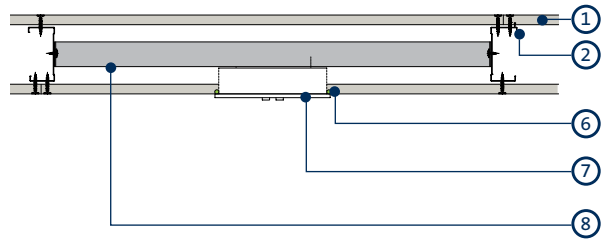
Standard zones of cabling

26



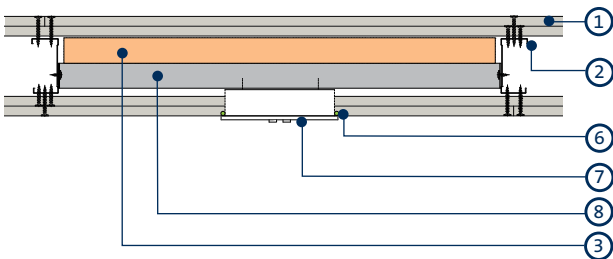
General arrangement of service support plates showing studs at 600mm centres

27



Socket box installation – up to 60 minutes fire resistance

28



Socket box installation – up to 120 minutes fire resistance

- 1 Gyproc plasterboard or Gyproc specialist board
- 2 Gypframe 'C' Stud
- 3 Stone mineral wool (minimum 80kg/m<sup>3</sup>) backing to socket box
- 4 Gypframe Service Support Plate
- 5 18mm plywood

- 6 Gyproc Sealant at switch box perimeter for improved acoustics
- 7 Electrical socket with metal back box fitted tight into plasterboard
- 8 Gypframe Folded Edge Standard Floor & Ceiling Channel receiving fixing of socket box – channel legs tabbed, bent and fixed to metal studs with Gyproc Wafer Head Drywall Screws

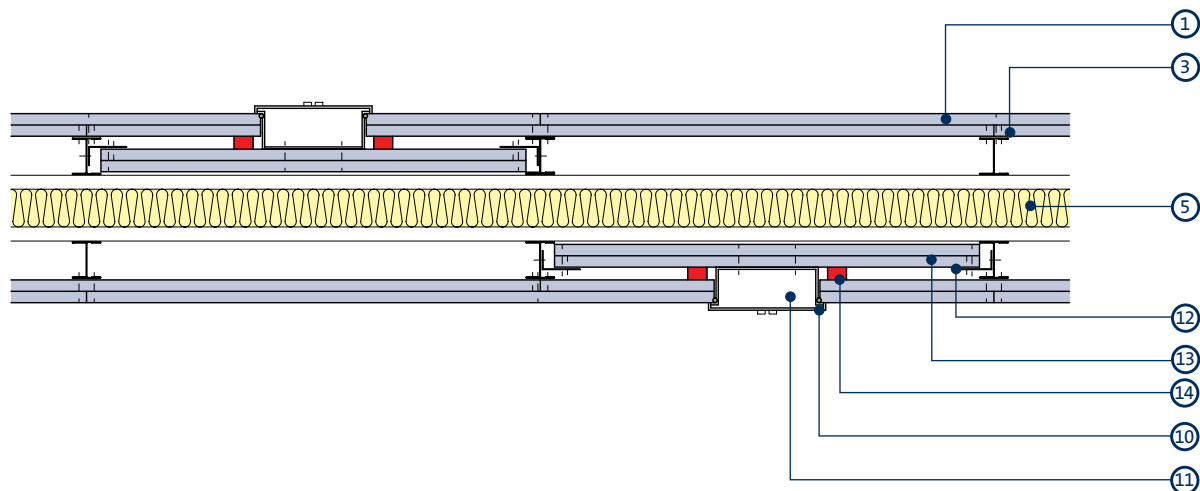
**NB** If Gypframe Service Support Plates are being installed and not immediately boarded, secure plates with a Gyproc Wafer Head Drywall Screw or Gyproc Wafer Head Jack-Point Screw.

# Technical performance and principles of system design

Service installations (continued)

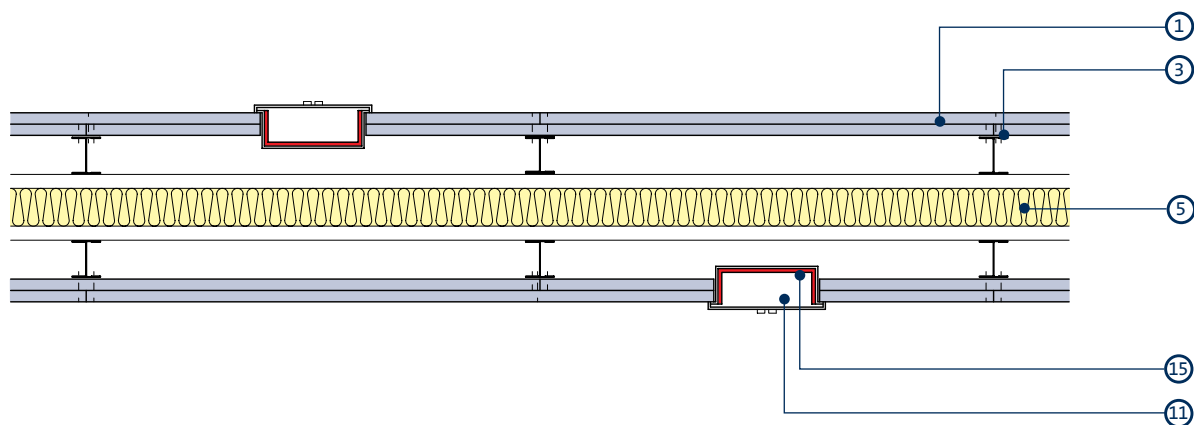
## Figures

29



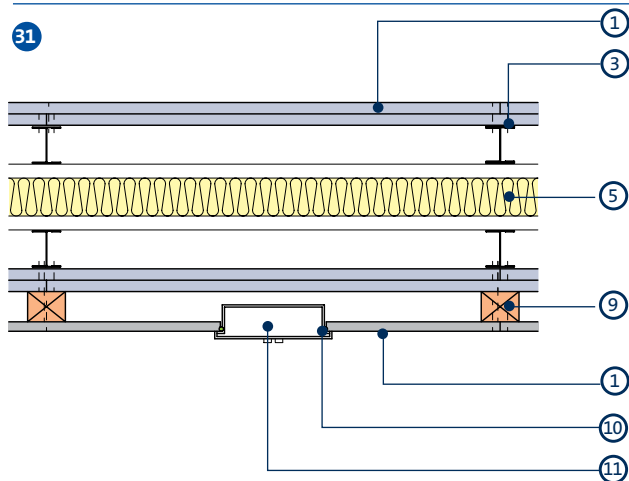
Electrical socket box with plasterboard baffle in GypWall QUIET IWL

30



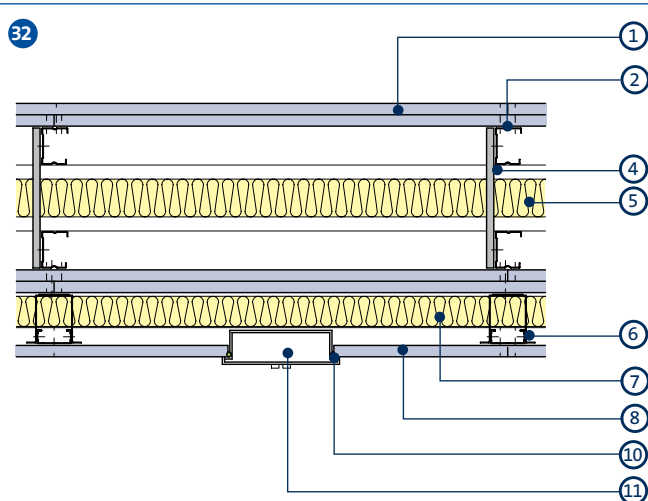
Electrical socket box with putty pad in GypWall QUIET IWL

31



Robust Details sacrificial lining where a slight performance downgrade is not detrimental to the system

32



Electrical socket box in sacrificial lining to GypWall QUIET

1 Gyproc plasterboard

2 Gypframe 'C' Stud

3 Gypframe 'I' Stud

4 Gypframe 99 FC 50 Fixing Channel

5 Isover acoustic insulation

6 GypLyner with minimum 70mm cavity

7 50mm Isover Acoustic Roll

8 15mm Gyproc SoundBloc

9 Timber batten

10 Gyproc Sealant

11 Electrical socket box

12 Gypframe GA4 Steel Angle

13 150mm high Gyproc plasterboard baffle to match partition lining

14 Fire-resistant seal where required

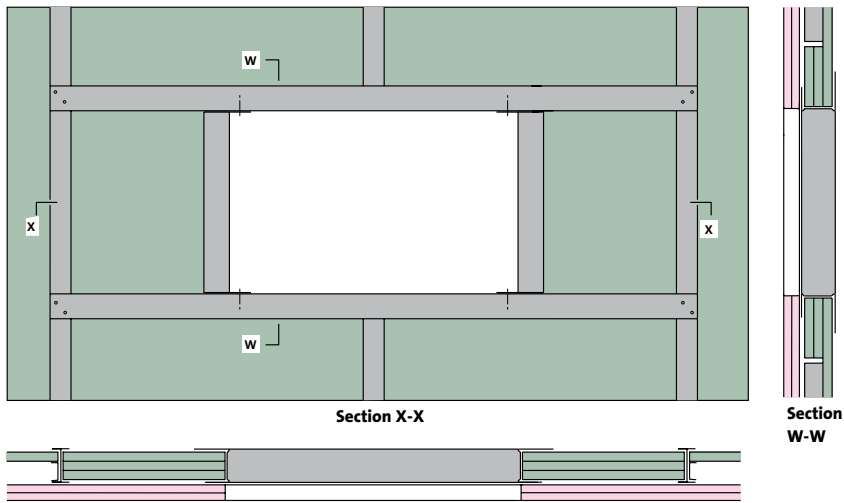
15 Putty pad (by others) in accordance with manufacturer's instructions

# Technical performance and principles of system design

Service installations (continued)

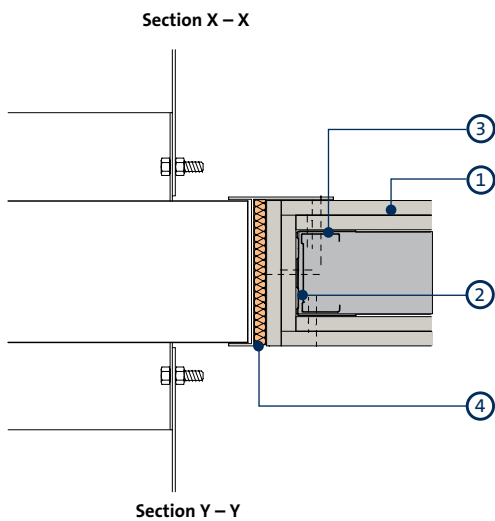
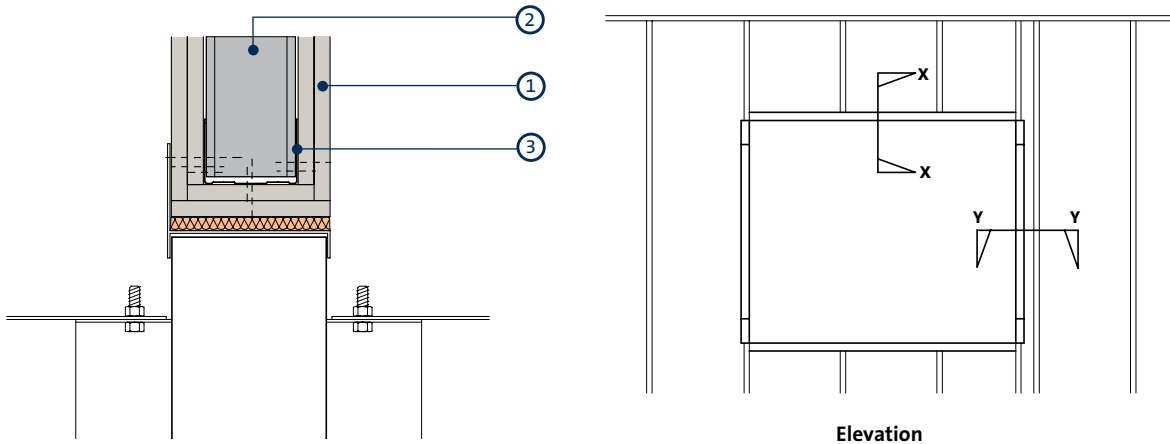
## Figures

33



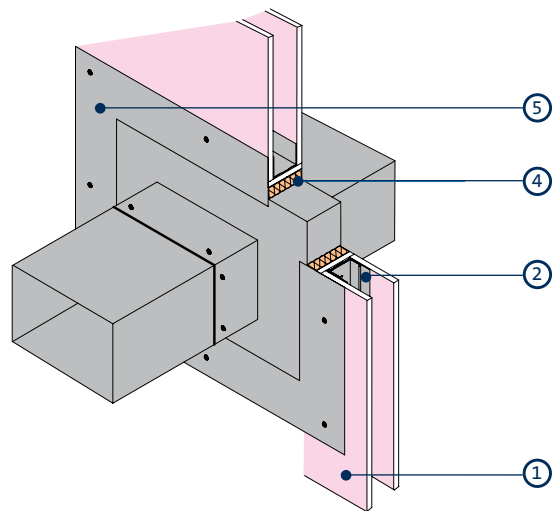
Opening bridging studs for duct / damper penetration within ShaftWall

34



Typical opening for service penetrations in fire-rated partitions

35



Fire rated construction in which the damper is supported by the partition (isometric view)

- 1 Gyproc plasterboard or Glasroc F specialist board
- 2 Gypframe 'C' Stud
- 3 Gypframe Floor & Ceiling Channel

- 4 Penetration seal as tested by damper manufacturer or proprietary alternative, confirmed as compatible by system designer / specifier (plasterboard lining around opening may not be required)
- 5 Damper (by others). Weight of damper should not exceed 57kg. Size damper should not exceed 1400 x 1200mm

# Technical performance and principles of system design

## Thermal insulation and condensation

### Legislation and guidance documents

#### Building Regulations – Thermal insulation

Minimum energy efficiency requirements in Ireland are set out in Building Regulation documents below:

##### Republic of Ireland

- TGD L – 2011 : Conservation of Fuel and Energy – Dwellings
- TGD L – 2008 : Conservation of Fuel and Energy – Buildings other than dwellings

##### Northern Ireland

- TB F1 – 2012 : Conservation of fuel and power in dwellings
- TB F2 – 2012 : Conservation of fuel and power in buildings other than dwellings

Compliance is based on both the carbon dioxide performance and the fabric energy efficiency of the dwelling. Compliance targets are given through the use of Dwelling Energy Assessment procedure (DEAP) in RoI and Standard Assessment Procedure (SAP calculation) in NI and although compliance cannot be demonstrated by the elemental U-value method, U-values are important requirements within the calculation. Limiting fabric parameter U-values are given but U-values better than these are likely to be required and the regulations include model U-values within a concurrent notional dwelling specification. Air permeability / airtightness is also a requirement within the SAP calculation. Refer to table 14a.

Compliance with the non-domestic regulations is based upon the carbon dioxide performance. Compliance targets are given through the use of the Simplified Building

Energy Model (SBEM) and although compliance cannot be demonstrated by the elemental U-value method, U-values are important requirements within the SBEM calculation. Limiting fabric parameter U-values are given but U-values better than these are likely to be required and the regulations include model U-values within a concurrent notional building specification. Air permeability is also a requirement within the SBEM calculation. Refer to table 14b.

Conservation of fuel and power in existing dwellings and in existing buildings other than dwellings are based on fabric energy efficiency and carbon dioxide performance with the need to meet U-values targets. Where an existing element forms part of the thermal envelope it must have a certain thermal value. This is known as the 'threshold' value. If the existing value of the element equals or is better than the threshold, no thermal renovation will be required. If it is worse than the threshold value then thermal renovation to achieve the required U-values has to be carried out. Refer to tables 15a and 15b.

#### Building Regulations – Condensation

In the Republic of Ireland the requirements are set out in Building Regulations Technical Guidance Document 'F'-Ventilation and 'L'-Conservation of Fuel and Energy. In Northern Ireland the requirements are set out in Building Regulations Technical Booklet 'C' – site preparation and resistance to contaminants and moisture, 'K' – Ventilation and 'F1&2' Conservation of fuel and power. The walls, floors and roof of the building shall adequately protect the building and people who use the building from harmful effects caused by interstitial and surface condensation. To provide resistance to surface condensation and mould growth, guidance is also given to ensure that in simple terms the minimum internal surface temperature is not more than 25% below roof temperature.

**Table 14a**

New dwellings	Republic of Ireland (TGD L Dwellings)		Northern Ireland (TB F1)	
	U-value (W/m <sup>2</sup> K)		U-value (W/m <sup>2</sup> K)	
	Limiting fabric parameters	Example dwelling specification	Area weighted average	Maximum at any point
Wall	0.21	0.13	0.3	0.7
Floor	0.21 (0.15 if Underfloor heating)	0.14	0.25	0.7
Roof	0.16	0.11	0.2	0.35
Party Wall	n/a	n/a	0.2	0.7

**Table 14b**

New buildings other than dwellings	Republic of Ireland (TGD L Buildings other than Dwellings)	Northern Ireland (TB F2)
	U-value (W/m <sup>2</sup> K)	U-value (W/m <sup>2</sup> K)
	Average elemental U-values	Area weighted average
Wall	0.27	0.35
Floor	0.25	0.25
Party Wall	-	0.2
Pitched roof, insulation at ceiling level	0.16	0.25
Pitched roof, insulation at rafter level	0.2	-
Flat roof or roof with integral insulation	0.22	0.2

# Technical performance and principles of system design

## Thermal insulation and condensation (continued)

**Table 15a**

Existing dwellings	Republic of Ireland (TGD L Dwellings)		Northern Ireland (TB F1)	
	U-value (W/m <sup>2</sup> K)		U-value (W/m <sup>2</sup> K)	
	Material alterations or material change of use	Average Elemental U-value - individual element or section of element	New thermal elements (including replacements for existing elements and non-exempt Conservatories & Porches)	Upgrading retained thermal elements
Wall	0.35 (0.55 Cavity Walls)	0.6	0.28	0.30 (0.55 Cavity insulation)
Floor	0.45 (0.25 Other exposed)	0.6	0.22	0.25
Pitched roof, insulation at ceiling level	0.16	0.35	0.16	0.16
Pitched roof, insulation at rafter level	0.25	0.35	0.18	0.18
Flat roof or roof with integral insulation	0.25	0.35	0.18	0.18

**Table 15b**

Existing buildings other than dwellings	Republic of Ireland (TGD L Buildings other than dwellings)		Northern Ireland (TB F2)	
	U-value (W/m <sup>2</sup> K)		U-value (W/m <sup>2</sup> K)	
	Material Alterations to, or Material Changes of Use of, Existing Buildings		New thermal elements (including replacements for existing elements)	Upgrading retained thermal elements
Wall	0.6		0.28	0.30 (0.55 Cavity insulation)
Floor	0.6		0.22	0.25
Pitched roof, insulation at ceiling level	0.35		0.16	0.16
Pitched roof, insulation at rafter level	0.35		0.18	0.18
Flat roof or roof with integral insulation	0.35		0.18	0.18

### Guidance documents referenced in national building regulations

#### Acceptable (RoI) or Accredited (NI) Construction Details

Published by Local Government, these are intended to assist the construction industry to comply with the performance standards published in the guidance documents. These are focused on issues concerning insulation continuity and airtightness, providing theoretical information and large scale indicative drawings. It can be accessed via the websites [www.planningportal.gov.uk](http://www.planningportal.gov.uk) (NI) or [www.environ.ie/housing/building-standards/tgd-part-l-conservation-fuel-and-energy/technical-guidance-document-l-2](http://www.environ.ie/housing/building-standards/tgd-part-l-conservation-fuel-and-energy/technical-guidance-document-l-2) (RoI)

#### BR443 U-value conventions

Published by the Building Research Establishment (BRE), it provides calculation methods for the determination of U-values of building elements and includes common issues, together with data on typical constructions and the thermal conductivity of materials.

#### BR262 Thermal insulation avoiding risks

Published by the BRE, it highlights risks, causes and solutions of thermal design. The guidance supports the Building Regulations and represents the recommendations on good design and construction practice associated with thermal standards.

#### BS EN 12524: 2000 Building material and products - Hygrothermal properties - Tabulated design values

This gives design data in tabular form for heat and moisture transfer calculations, for thermally homogeneous materials and products commonly used in building construction. It also gives data to enable calculations and conversion of design thermal values for various environmental conditions.

#### BS EN ISO 13788: 2012 Hygrothermal performance of building components and building elements. Internal surface

#### temperature to avoid critical surface humidity and interstitial condensation – Calculation method

This deals with the critical surface humidity likely to lead to problems such as mould growth on the internal surfaces of buildings and interstitial condensation within a building component. It also deals with estimation of the time taken for a component, between high vapour resistance layers, to dry, after wetting from any source, and the risk of interstitial condensation occurring elsewhere in the component during the drying process.

#### BS EN ISO 6946: 2007 Building components and building elements. Thermal resistance and thermal transmittance - Calculation method

This gives the method of calculation of the thermal resistance and thermal transmittance of building components and building elements, excluding doors, windows and other glazed units; components that involve heat transfer to the ground; and components through which air is designed to permeate. The calculation method is based on the appropriate design thermal conductivities or design thermal resistances of the materials and products involved.

#### BS 5250: 2011 Code of practice for control of condensation in buildings

This describes the causes and effects of surface and interstitial condensation in buildings, and gives recommendations for their control.

#### BS 9250: 2007 Code of practice for design of the airtightness of ceilings in pitched roofs

This describes methods that can be used to meet the “well sealed ceiling” requirements defined in BS 5250 for cold and warm pitched roofs and provides robust design details for the construction of more airtight ceilings and for the control of air movement into pitched roofs.

# Technical performance and principles of system design

## Thermal insulation and condensation (continued)

### The provision of thermal insulation

#### Reducing heat loss

Any building with an internal temperature higher than the external temperature will lose heat. Thermal insulation reduces this heat loss and therefore helps to conserve energy and reduce heating costs. To comply with Building Regulations, levels of thermal performance are required for the external walls, roof and floors of almost all building types. Adequate insulation must also be provided for hot water heating services, pipes, warm air ducts and hot water storage vessels.

Savings are maximised where insulation is supported by other measures such as automatic controls, which govern the operation and output of heating systems and the temperature of stored water.

In addition to providing high levels of thermal performance in newly constructed buildings, insulation products and systems are also incorporated into existing buildings where the energy efficiency of the building may be inadequate. This will apply equally to both non-domestic buildings and to the existing housing stock. The scale of inefficiency for the latter has been highlighted by various Government surveys and subsequent corrective measures. When specifying the insulation system for a particular building it is important to take into account both the heating regime and the pattern of usage of the building.

#### Infrequently heated buildings

If a building is only infrequently heated, thermal insulation materials should be located as near as possible to the internal surface of exposed building elements to provide a quick thermal response to heating input. This is essential in such conditions to reduce internal surface condensation during the warm-up period, when the maximum amount of water vapour is often produced. It will also ensure that comfortable room temperatures are quickly achieved.

#### Regularly heated buildings

Heating regimes may be of a regular nature, with relatively equal periods of heating activity and non-activity, as may occur in housing during winter months. In this situation, traditional forms of high mass construction, such as externally insulated solid leaf walls or to a lesser extent double leaf cavity walls, can effectively exploit the 'heat store' concept when thermal insulation is positioned within the cavity. Note however that this is more applicable in our climate to non-domestic buildings because residential construction neither gains from extreme external temperatures or high internal heat outputs. These may be present in office buildings for example due to the number of staff or other high internal gains from server rooms or kitchens. Extreme air temperature fluctuations within the building can be subdued as heat stored in components within the insulation 'envelope' is dissipated back into the building. Further benefits can be derived from the reduced size and complexity of space heating equipment necessary to maintain room temperatures.

#### Airtightness

Airtightness describes the air leakage characteristics of a building. This determines the uncontrolled background ventilation or leakage rate of a building.

Airtightness is expressed in terms of a whole building leakage rate at an artificially induced pressure (usually 50Pa). The lower the air leakage rate, the greater the airtightness. For example, within TGD L (RoI domestic) an upper limit on air permeability of 7m<sup>3</sup>/hour/m<sup>2</sup> and within TB F1 (NI) 10m<sup>3</sup>/hour/m<sup>2</sup> is required. In practice, most designs will need to be significantly better than this.

Improving a building's airtightness is crucial to improving the energy performance of a building.

Although air leakage can occur directly, the majority of leaks occur indirectly. Air leakage paths are often complicated and therefore air leakage can be difficult to trace and seal effectively. However, the following is a list of some example air leakage paths:

- Cracks, gaps and joints in the structure
- Timber floors
- Joist penetrations of external walls
- Windows, doors, roof windows and AOVs
- Loft hatches
  - Tubular rooflights
- Skirting boards
- Chimney and flues
- Service entries, ducts and electrical components
  - Light fittings
  - Ventilators, and extraction outlets
- Areas of un-plastered walls

To improve airtightness when using a plasterboard internal drylining system, e.g. **Drilyner**, continuous ribbons of adhesive should be applied around the perimeter of the wall and around openings / penetrations to seal airpaths. Gyproc Airtite Quiet can be used on most external masonry walls to seal air paths. This may also improve the airtightness before a drylining system is applied to the wall, alternatively Gyproc Hard Coat combined with our finish plaster may be used as an airtight solid plastered wall finish.

### Terminology

#### Thermal conductivity ( $\lambda$ )

This is a measure of a material's ability to transmit heat, and is expressed as heat flow in watts per metre thickness of material for a temperature gradient of one degree Kelvin (K). It is expressed as W/mK.

Generally, dense materials have high thermal conductivity and are inefficient thermal insulants. Lightweight materials

# Technical performance and principles of system design

## Thermal insulation and condensation (continued)

have low conductivity and can be efficient thermal insulants. The lower the  $\lambda$  value of a material, the better its insulating efficiency.

### Thermal resistance (R)

This is the measure of the resistance to the passage of heat offered by the thickness of a material and is expressed as  $\text{m}^2\text{K}/\text{W}$ . The thermal resistance of a material is obtained by the following calculation:

$$R = \frac{t}{\lambda}$$

Where  $t$  = thickness in (m) and  $\lambda$  = thermal conductivity ( $\text{W}/\text{mK}$ )

### Thermal transmittance (U-value)

This is a property of the whole construction, including air spaces, and is a measure of its ability to transmit heat under steady state conditions. It is calculated by taking the reciprocal of the sum of all the individual thermal resistances, taking into consideration any thermal bridging, and is expressed as  $\text{W}/\text{m}^2\text{K}$ . The lower the U-value of the element the better its thermal insulation.

For the purpose of calculating U-values, thermal resistances for the inside and outside surfaces of a building element, and for any cavities within it, have to be taken into account. This is in addition to thermal resistances directly relating to the actual thickness of materials.

The R-values of inside surfaces, outside surfaces and of any cavities will vary according to the surface emissivity. Emissivity should be taken as high for all normal building materials other than polished or metal surfaces, such as aluminium foil, which are regarded as low.

U-value calculations are used as a common basis for comparing different constructions or for meeting a stated figure. When calculating the U-value of some constructions the effect of components that repeatedly bridge the insulation layer, such as mortar joints in lightweight blockwork, studs in timber and metal framed walls, wall ties, and roof joists, should be taken into account. The U-value is calculated through the thermal bridge and combined with the U-value through the insulation in proportion to its face area, often resulting in a higher U-value (i.e. lower performance) for the element. More insulation may be needed to compensate for the presence of thermal bridges and return the U-value to a specified level. This can also be achieved by changing to a more efficient insulant. The additional heat loss for non-repeating thermal bridges, such as details at window and door openings, is determined separately.

### Thermal mass / heat sink

Thermal mass (also discussed under 'regularly heated buildings above'), describes a material's capacity to absorb, store and release heat. For example, water and concrete have a high capacity to store heat and are referred to as 'high thermal mass' materials. Insulation foam, by contrast,

has very little heat storage capacity and is referred to as having 'low thermal mass'. Gyproc plasterboards and Rigidur are effective in contributing towards the thermal mass effect. Thermal mass design, for example in school buildings, is a means of ensuring overheating is kept under control.

This principle is included with the SBEM and SAP or DEAP procedure within which it is expressed as a Kappa ( $\kappa$ ) value in calculating the thermal mass parameter to characterise the thermal mass of the building. As an example within SAP, the heat capacity  $\kappa$  of a single layer plasterboard partition is given as  $9 \text{ kJ}/\text{m}^2\text{K}$ .

## Condensation control in buildings

### Harmful effects of condensation

Condensation can be one of the worst problems that designers, owners or occupants of buildings experience.

Dampness and mould growth caused by surface condensation can not only be distressing to the occupants of a building, but can eventually lead to health risk to the occupants and or damage in the building itself.

The thermal insulation and ventilation requirements of Building Regulations aim to reduce the risk of condensation and mould growth occurring in new buildings. However, designers should take care to eliminate all problems caused by condensation, particularly in refurbishment projects on existing buildings, where situations exist that are not directly covered by the regulations.

### Reducing the risk

Due to changes in building design, occupancy patterns and increased thermal requirements, all buildings, particularly houses, are more sensitive to condensation now than in previous years. Homes tend to be heated intermittently and moisture-producing activities are concentrated into relatively short periods of time.

Thermal insulation correctly positioned within specific building elements, combined with adequate heating and the necessary water vapour control and ventilation, where appropriate, should ensure trouble-free design.

### How condensation occurs

At any given temperature, air is capable of containing a specific maximum amount of water in vapour form. The warmer the air, the greater the amount of water vapour it can contain. Conversely, the lower the temperature, the smaller the amount. Water vapour in air exerts a pressure, called the vapour pressure. Any differential in vapour pressure causes vapour to diffuse from high to low pressure areas.

Warm air inside a building usually also contains more moisture than external air, due either to the occupants' activities or resulting from the evaporation of residual moisture in new construction. This creates a pressure differential across structural elements. Water vapour in the internal air, being at a higher pressure, tends to diffuse through the structure towards the colder, lower pressure exterior.

# Technical performance and principles of system design

## Thermal insulation and condensation (continued)

If moisture-laden air comes into contact with a cold surface it will cool. As it cools, the amount of water it can hold in vapour form reduces until, at a specific temperature called the dew point, it becomes saturated. Water is then deposited in the form of condensation.

### Surface condensation

Surface condensation occurs when air containing water vapour comes into contact with highly vapour resistant surfaces, which are at, or below, the dew point temperature.

Refer to figure 36 – ‘Surface condensation’. It usually shows itself as beads of water, damp patches, and, where the condition persists, mould growth.

Surface condensation can be in localised zones in a particular building element caused by the presence of ‘cold bridges’, such as mortar joints in walls, which can be colder than the rest of the wall structure.

In addition, warm moist air will diffuse through a building into colder rooms, such as poorly heated bedrooms and stairwells. This is one reason why surface condensation does not always occur in the room where water vapour is produced.

### Interstitial condensation

Warm moist air will also diffuse through building elements to reach colder, lower pressure conditions outside. If the building materials have low water vapour resistance it is possible for condensation to occur within the building element. This will occur on the first cold surface, at or below dew point temperature, which is encountered by the moisture vapour on its passage through the structure. As an example, for double skin masonry walls, the position for condensation to form is on the inner face of the outer leaf whether or not insulation is included in the cavity. Refer to figure 37 – ‘Interstitial condensation’.

There is no evidence to suggest that interstitial condensation will occur within the core of building materials under general building and climatic conditions. For other types of building structure vapour control layers can help to eliminate the risk of interstitial condensation. It is recommended that the risk of harmful condensation be assessed using an appropriate calculation procedure, for example as described in I.S. EN ISO 13788: 2002 and/or I.S. EN 15026: 2007. Refer to table 17 for typical hygrothermal properties.

## Designing to reduce condensation risk

### Thermal insulation

Thermal insulation helps to reduce the risk of surface condensation by maintaining surfaces above the dew point temperature subject to adequate heating being provided.

In buildings that are heated infrequently, the thermal insulation should be located as near as possible to the internal surface of building elements to provide rapid thermal response. These surfaces will then be less prone to surface condensation during the warm-up period, which is often when the maximum amount of water vapour is

produced. Where the greater part of the insulation is located to the internal surface, strategies must be employed to ensure interstitial condensation does not occur behind the insulation. Please contact our technical department for further advice in these scenarios.

Where the insulation is being ‘topped up’ with internal insulation, this is far less of a concern, e.g. where adding internal insulation to a cavity wall. This will also reduce the thermal bridge effects in a building, e.g. at lintels and reveals and at the gable wall below an attic.

For most constructions the use of vapour permeable insulation, in combination with other building materials of low vapour resistance, will allow the structure to breathe naturally. In this instance, the likely occurrence of interstitial condensation can be managed but must be considered in the context of the complete wall as a ‘system’ including external render and use of the building/room.

Thermal bridging, particularly at junctions, abutments and openings can occur and therefore good detailing is essential. This is now a critical issue in the context of new buildings based on imminent mandatory standards for nearly Zero Energy Buildings (nZEB). Information on Psi ( $\psi$ ) values (linear thermal transmission) relating to thermal bridging details is contained within SAP, and within Accredited Construction Details (ACDs) which are available to view at [www.planningportal.gov.uk](http://www.planningportal.gov.uk) (NI) or [www.environ.ie/housing/building-standards/tgd-part-l-conservation-fuel-and-energy/technical-guidance-document-l-2](http://www.environ.ie/housing/building-standards/tgd-part-l-conservation-fuel-and-energy/technical-guidance-document-l-2) (RoI).

Note that providing a simple calculation of the ‘y factor’, essentially the average u-value for all thermal bridges in the building can reduce the costs and need for alternative efficiency measures including renewable energy solutions.

### Heating

Adequate heating helps to keep the temperature of the internal surfaces above the dew point. Ideally, an air temperature above 10°C should be maintained in all parts of the building.

### Ventilation

Ventilation removes the water vapour produced within a building to the outside air. Adequate ventilation, including the provision of small controllable slot ventilators in windows, electrical extractor fans controlled by humidistats in bathrooms and kitchens, and cooker hoods extracted to the outside air, will help to reduce harmful condensation and mould growth. Ideally, ventilation should control the internal air to between 40% and 70% relative humidity (RH) for human occupation.

Condensation can occur in roof spaces of slated or tiled pitched roofs of dwellings and in timber joisted flat roofs with insulated ceilings, unless adequate ventilation is provided. Precautions should be taken, in particular the provision of adequate cross-ventilation of the roof spaces to the outside. The main requirements for ventilation in buildings are given in BS 5250 and referenced in national building regulations, TGD F (RoI) and TB K (NI). Note that

# Technical performance and principles of system design

## Thermal insulation and condensation (continued)

in accordance with BS 5250, pitched roofs may not require active ventilation where a low resistance (LR) underlay is used in combination with a permeable roof finish such as natural slates or concrete tiles. Please contact our the Gyproc Technical Department for further information.

### Vapour control layer

A vapour control layer, usually in the form of a membrane, is used to substantially reduce the transfer of water vapour through a building element in which it is incorporated. Refer to table 16 for a few example wall and roof constructions. A vapour control layer, positioned on the warm side of the thermal insulation within a building element, helps to reduce the risk of interstitial condensation occurring within that element. However, other precautions may also be necessary, either in combination with, or as alternatives to, a vapour control layer. These include the use of ventilated cavities and the provision of materials of low vapour resistance, particularly on the colder side of the construction.

Vapour control layers should be as airtight as possible. Holes and penetrations for services should be cut neatly and suitably sealed, or localised condensation may still occur. It is recommended that the risk of harmful interstitial condensation is assessed using the calculation procedure given in I.S. EN ISO 13788: 2002 and/or I.S. EN 15026: 2007.

### Existing masonry walls

The Isover Optima system incorporating Gyproc plasterboard, metal framing, Metac insulation and Optima clips is agrément certified by the NSAI and BBA for internal insulation of a range of masonry wall types. Suitability and the level of insulation in the system depends on the exposure and porosity of the external leaf as well as internal humidity. High risk areas include porous unrendered solid brick walls and where intermediate floors are built into the wall. Please contact the Gyproc Technical Department for further information.

### New masonry walls

#### Full fill or partial fill cavity

Positioning Isover CWS 32 or 36 Batt insulation within the cavity, either full fill or partial fill, can maintain the internal surface of the wall above dew point temperature. Therefore a water vapour resistant treatment to the surface of internal plaster finishes is not always necessary because any interstitial condensation will occur on the inner surface of the outer leaf. Gyproc plasters, or Gyproc WallBoard, fixed in the Drilyner or Gyplyner systems, form suitable linings. Gyproc WallBoard **DUPLEX** can be specified in conjunction with the (mechanically fixed) Drilyner **MF** or Gyplyner systems, however exposed blockwork is typically highly porous and should first be sealed with a parge coat layer of plaster such as Gyproc Airtite Quiet. For higher levels of airtightness and moisture management we recommend Isover Vario KM duplex be used (taped and sealed) behind our non-duplex boards.

### Timber / steel frame walls

To reduce the risk of interstitial condensation occurring on the inner surface of the sheathing, a vapour control layer is required as part of the internal lining, refer to NHBC (Technical Standards for domestic applications) at nhbc.co.uk. Isover timber frame insulation is positioned within the stud cavity and Gyproc **DUPLEX** grade plasterboards can be used as the internal face lining or Isover Vario KM Duplex membrane and an alternative Gyproc plasterboard. The dew point will then fall within the outer cavity or external cladding.

Where the insulation does not meet the U-value requirement alone, a drylining system using a thermal laminate could be considered which will provide both thermal performance and a vapour control layer however, system designers and installers must ensure that fire performance of the system is fully validated by appropriate fire test evidence where required. Note that in order to mitigate risks of interstitial condensation, a maximum of one third the total resistance of insulation in the construction may be provided to the inside of the vapour control layer. This is commonly referred to as the 'one third rule'.

### Pitched roofs

#### Horizontal insulated ceilings, e.g. cold loft space

Positioning a vapour control membrane at ceiling level should reduce the amount of water vapour migrating into the roof space. In practice, however, a continuous barrier is unlikely to be achieved because of the difficulty of sealing leaks through loft access hatches, electrical wiring drops, pipe penetrations and cracks. Gaps in the ceiling can be much more significant for heat losses and water vapour transfer from convection / migration than diffusion through the ceiling itself. Appropriate cross-ventilation of the roof space is necessary.

Insulation, e.g. Isover Spacesaver range, is located on top of and between the ceiling joists and Gyproc plasterboard fixed to the underside. Gyproc **DUPLEX** grade plasterboards can be used as the ceiling lining if a vapour control layer is required. The amount of ventilation is set out in TGD F (RoI) and TB K (NI). An alternative compliance method is set out in BS 5250 and depends on the permeability of roof finish and airtightness of ceiling below. For a pitched roof (>15° pitch), generally a minimum 50mm clear cavity well vented space above the insulation to the external air is required with the equivalent of a continuous 10mm gap in the eaves/soffit at the perimeter. With a low resistance roof underlay (<0.4 MNs/g) and a well sealed ceiling below, this may be reduced to a 3mm gap or equivalent. For well-sealed ceilings, it is recommended to use Isover Vario membranes, taped and sealed.

#### Sloping insulated ceilings, e.g. warm room-in-the-roof

Isover Metac insulation is located between the rafters and a minimum 50mm ventilation zone above the insulation is typically required. However, per BS 5250 if the roof finish is air permeable or the tiling batten / counter batten cavity is vented and a low resistance underlay is used, the 50mm vented zone may not be required. This will also improve the wind-tightness of the assembly.

# Technical performance and principles of system design

## Thermal insulation and condensation (continued)

### Warm construction

In warm roof construction, the thermal insulation (by others) is located on top of a high performance vapour control layer over the roof decking. The construction is referred to as a warm roof because in winter, with adequate heating, the temperature of the vapour control layer, and of the materials below it, is maintained close to that of the internal air. Specific requirements in BS5250 set out that ceilings under warm pitched roofs must be 'well sealed' in order to minimize the transfer of water vapour by air movement, diffusion and convection. In addition, recent building science has shown that a warm roof must provide either no insulation above the rafters (so that solar gains on a dark colour slate/tile roof may keep the top of the rafters warm) or a minimum of 50mm rigid insulation be provided (which will block out solar gain to the rafters but maintain sufficient temperatures below.)

### Flat roofs (<15° pitch)

#### Cold construction

In a cold roof construction, the thermal insulation, e.g. Isover Metac, is located directly above the ceiling. Most of the structure is on the unheated side of the insulation and is therefore vulnerable to the risk of interstitial condensation. To reduce this risk, cross-ventilation must be provided above the insulation to disperse water vapour to the outside. Generally a minimum 50mm clear cavity well vented to the external air is required. Flat roofs will require 25mm fresh air gap or equivalent at each end of the cavity. An effective vapour control layer should be provided at ceiling level and perforations for pipes, electrical wiring drops, etc., should be sealed. Refer to figure 38 – 'Timber flat roof, cold type'. Gyproc **DUPLEX** grade plasterboards can be used as the internal face ceiling lining.

**Table 16 – Recommendations for the use of vapour control layers to reduce the risk of interstitial condensation in some example external wall and roof constructions in dwellings**

Element	Type of external wall	Vapour control layer required?	Comments
External walls	Timber or metal frame (brick outer leaf)	Yes	Low vapour resistance sheathing board and breather membrane.
	Brick / insulated cavity / block Gyproc plasterboard lining or plaster	No	Consider vapour control layer in adverse conditions
	Solid masonry	Yes	Please contact Technical Department for further information.
Roofs	Cold pitched roof, tiles or slates on battens on membrane over loft space	Recommended	Especially important with higher levels of insulation
	Ceiling and insulation horizontal	Recommended	Ventilated in accordance with BS 5250 and Approved Document F. Consider vapour control layer in adverse conditions.
	Warm pitched roof, tiles or slates on battens on membrane Ceiling and insulation inclined	Yes	Ventilated in accordance with BS 5250 and TGD F / TB K. Minimum 50mm ventilation zone above insulation (unless permeable or ventilated tiling battens/counter batten cavity over breathable membrane used)
	Cold flat roof Insulation at ceiling level (horizontal)	Yes	Ventilated in accordance with BS 5250 and TGD F / TB K. Minimum 50mm ventilation zone above insulation and 10mm continuous gap at eaves

Where a vapour control layer is used, it must be airtight, e.g. holes and penetrations for services etc., cut neatly and suitably sealed.

**Table 17 – Hygrothermal properties**

Material	Specific heat capacity, Cp <sup>1</sup> J/(kgK)	Water vapour resistance factor, dry <sup>1</sup> μ	Equivalent water vapour resistivity <sup>2</sup> MNs/gm	Typical vapour resistance MNs/g
Gypsum plasterboard	1000	10	50	0.63 (12.5mm thickness)
Gypsum plaster	1000	10	50	0.65 (13mm thickness)
Mineral wool	1030	1	5	0.25 (50mm thickness)
Expanded polystyrene	1450	60	300	15.0 (50mm thickness)
Extruded polystyrene	1450	150	750	37.5 (50mm thickness)
Phenolic foam	1400	50	250	12.5 (50mm thickness)
Polyisocyanurate foam	1400	60	300	15.0 (50mm thickness)
Vapour Control layer in DUPLEX grade Gyproc plasterboard	-	-	-	60

<sup>1</sup> Taken from BS EN 12524 Building materials and products - Hygrothermal properties - Tabulated design values.

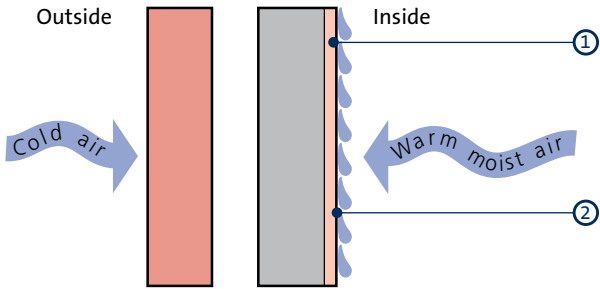
<sup>2</sup> Using conversion factor as per BS 5250 Code of practice for control of condensation in buildings.

# Technical performance and principles of system design

## Thermal insulation and condensation (continued)

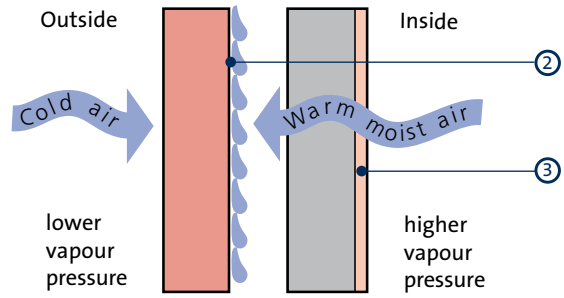
### Figures

36



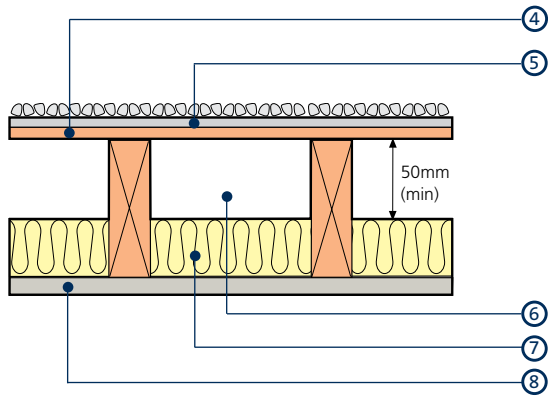
Surface condensation

37



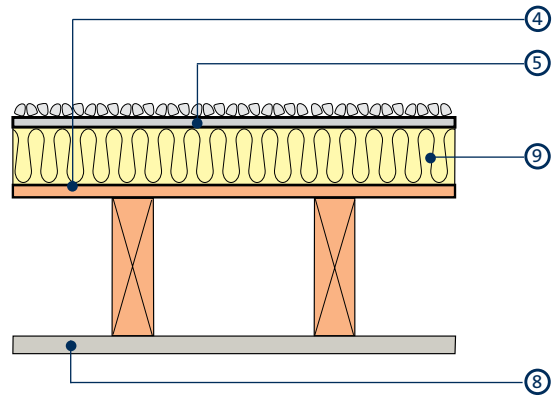
Interstitial condensation

38



Timber flat roof, cold type

39



Timber flat roof, warm type

- 1 High vapour resistance surface
- 2 Surface at or below the dewpoint
- 3 Low vapour resistance surface
- 4 Timber roof decking
- 5 Built-up felt (or similar) with solar reflective finish

- 6 Cross-ventilated roof cavities
- 7 Isover acoustic insulation
- 8 12.5mm Gyproc WallBoard DUPLEX
- 9 Insulation (by others)

# Technical performance and principles of system design

## Sustainability

### Sustainability

Our mission is to develop innovative products and services that help customers build better spaces to live, work and play. In every kind of building – from home to work, from the local supermarket to the local hospital – we help to create partitions, provide comfort, protect against fire and insulate against sound.

With over 80 years' experience in plaster, plasterboard and ceiling solutions, we have a multitude of high performance products and systems.

You'll find our plaster, plasterboard, metal and ceiling solutions in almost every kind of building in the country. Builders, tradesmen and specifiers choose our products because they offer the best acoustic, thermal insulation and fire protection performance.

#### Standards and legislation

There are many building standards and environmental assessment methods that apply to our industry such as:

- Building Regulations
- The BRE Environmental Assessment Method (BREEAM)
- Irish Green Building Council Home Performance Index (HPI)
- Leadership in Energy and Environmental Design (LEED)
- Green Guide Ratings

### Construction Products Regulations

From 1st July 2013, under the Construction Products Regulation 2011 (CPR), it has been mandatory for manufacturers to draw up a declaration of performance (DoP) and apply CE marking to any of their construction products, which are covered by a harmonised European standard (hEN) or conforms to a European Technical Assessment (ETA), when they are placed on the market. A construction product is any product or 'kit' which is produced and placed on the market for use in a permanent manner in construction works, and the performance of which has an effect on the performance of the construction works.

The CPR builds upon the previous legislation and aims to break down technical barriers to trade in construction products within the European Economic Area (EEA).

To achieve this, the CPR provides for four main elements:

- 1 A system of harmonised technical specifications
  - Defines EEA-wide methods of assessing and declaring all the performance characteristics
  - Must meet seven basic requirements for construction works. These cover:
    - Mechanical resistance and stability
    - Safety in case of fire
    - Hygiene, health and environment
    - Safety and accessibility in use
    - Protection against noise
    - Energy economy and heat retention
    - Sustainable use of natural resources
- 2 An agreed system of conformity assessment for each product family
- 3 A framework of notified bodies
- 4 CE marking of products

#### CE marking

CE marking enables a product to be placed legally on the market in any Member State. However, this does not necessarily mean that the product will be suitable for all end uses in all Member States.

CE marking indicates that a product is consistent with its Declaration of Performance (DoP) as made by the manufacturer. The declaration varies according to the particular harmonised technical specification covering the product. As such, decision makers (e.g. designers and specifiers) should understand the relevant performance requirements for the product.

#### Declarations of Performance (DoP)

By making a DoP the manufacturer, importer or distributor is assuming legal responsibility for the conformity of the construction product with its declared performance. The information to be contained in them is detailed in Annex ZA of a hEN or in a section of the ETA. DoPs must be supplied either in paper form or by electronic means which includes permission to make them available on a website.

Together with the technical specification, the DoP should give all the information needed by specifiers and regulators to judge whether the product meets all relevant regulations in the Member State upon whose market it is to be placed.

Where applicable, the DoP should be accompanied by information on the content of hazardous substances in the construction product to improve the possibilities for sustainable construction and to facilitate the development of environment-friendly products.

Copies of DoPs are available on our website: [gyproc.ie](http://gyproc.ie)

# Technical performance and principles of system design

## Sustainability (continued)

### Certifications

#### **ISO 14001:2004 – Environmental Management Systems: Requirements with guidance for use**

*ISO 14001* specifies the requirements for an environmental management system (EMS). It applies to those environmental aspects which the organization has control over and which it can be expected to have an influence. The standard applies to management systems which a site or organisation might employ, but does not directly relate to products. It is not a product certification system or label. The standard itself does not state specific environmental performance criteria; this is down to the site or organisation to do.

As part of our drive to continuously improve our performance, we have invested significant resource in developing environmental management systems certified to *ISO 14001:2004*.

In 2004, we achieved *ISO 14001:2004* certification across the whole of our manufacturing, mining and support functions in Ireland. This certification emphasises the stringent environmental standards maintained across the business and enables us to support customers through the delivery of sustainable construction products as advocated by BREEAM and the BRE Green Guide.

A copy of the certificate is available on our website: [gyproc.ie](http://gyproc.ie)

#### **ISO 9001:2008 – Quality Management Systems: Requirements**

*ISO 9001* is an internationally recognised and well established quality framework, currently used by more than 897,000 organizations in 170 countries worldwide, and sets the standard for quality management systems.

We have been certified to *ISO 9001* across the whole business since 2003. The business has continuous assessment visits every 6 months, and the latest certificate was reissued under the revised *ISO 9001:2008* in January 2016.

The scope of the *ISO 9001:2008* Certificate is the same as the *ISO 14001* certificate. A copy of the certificate is available on our website: [gyproc.ie](http://gyproc.ie)

#### **OHSAS 18001:2007 – Occupational Health and Safety Management Systems: Requirements**

*OHSAS 18001:2007* is an internationally recognised assessment specification for occupational Health and Safety management systems. It was developed by a selection of leading trade bodies, international standards and certification bodies to address a gap where no third-party certifiable international standard exists.

Health and Safety is our core value. Our aim is to always be injury-free. We passionately believe that our employees, and other stakeholders, should go home in the same condition as they arrived. We set the target of zero accidents at work for employees, visitors and contractors.

Our culture is one where safety is everyone's responsibility. Our people are encouraged to lead from within, through a programme of employee engagement and safety awareness, which includes functional safety committees, safety initiative worker groups and leadership groups. The business uses tools such as SUSA (Safe and Unsafe Acts) discussions and SMAT (Safety Management Audit Tool) to highlight safety concerns and correct them.

Keeping employees fit, happy and healthy is crucial for us. Our in-house occupational health team provide periodic health surveillance and on-going assessments with lifestyle guidance.

As part of our drive to continuously improve our performance, we have invested significant resource in developing our safety management systems and certifying them to *OHSAS 18001:2007*

Copies of our certificates are available on our website: [gyproc.ie](http://gyproc.ie)

#### **ISO 50001:2011 – Energy Management System**

*ISO 50001* is based on the management system model of continual improvement also used for other well-known standards such as *ISO 9001* or *ISO 14001*. This makes it easier for organisations to integrate energy management into their overall efforts to improve quality and environmental management.

*ISO 50001:2011* provides a framework of requirements for organisations to:

- Develop a policy for more efficient use of energy
- Fix targets and objectives to meet the policy
- Use data to better understand and make decisions about energy use
- Measure the results
- Review how well the policy works
- Continually improve energy management

We have been carefully managing our energy consumption for a number of years, using the well-established tools and techniques familiar to our business. As a result of this our management systems have been certified to *ISO 50001: 2011*. This international standard is about implementing and maintaining systems and processes to manage our energy consumption.

One of the key elements in any work we do is training and awareness of our employees. In particular when it comes

# Technical performance and principles of system design

## Sustainability (continued)

to energy, understanding reduction opportunities enables our employees to minimise the energy that we use. We use various communications, teams and courses to deliver this message.

As far as we are concerned, energy management should not be seen as special, or anything out of the ordinary, it is an integral part of what we do every day. Gaining certification of our established energy management systems will ensure an integrated approach to reducing the overall impact of our manufacturing process.

### **BES 6001 – Certified responsible sourcing**

For Environmental Assessment Tools such as BREEAM it is becoming increasingly important for the building industry to be able to demonstrate responsible sourcing, and supply chain management.

Currently Chain of Custody and Responsible Sourcing is synonymous within the timber market, where there are internationally recognised standards and schemes.

Saint-Gobain have, through the Construction Products Association, been involved with the BRE since 2007 with work to develop a Responsible Sourcing Standard.

The standard, *BES 6001*, describes a framework for the organisational governance, supply chain management and environmental and social aspects that must be addressed in order to ensure the responsible sourcing of construction products.

Independent, third party assessment and certification against the requirements of *BES 6001* then give the organisation the ability to prove that an effective system for ensuring responsible sourcing exists and add credibility to any claims made.

Certification to *BES 6001* can contribute to points and credits under BREEAM. An 'Excellent' rating results in products being classified as Tier Two under Mat 03 in BREEAM 2011, providing 3.5 of a maximum 4 points and making it easier for customers to achieve a higher number of points towards credits at no additional cost.

Copies of the BRE standard are available from the BRE's Green Book Live website: [greenbooklive.com](http://greenbooklive.com)

We recognise the importance of independently verified Responsible Sourcing Certification to provide assurance to our customers that they are sourcing materials responsibly and sustainably.

UK manufactured Gyproc plasterboards, Glasroc specialist boards, Hard Coat plaster, Gypframe metal and Gyproc Cove have all been awarded 'Excellent', the highest possible rating to *BES 6001*.

### **Products not manufactured by Gyproc**

As previously stated, the ISO and OHSAS standards are not product certifications. They certify the management systems of companies within the supply chain. All products that are merchandised (i.e. bought in and not manufactured by us) and all processes conducted by us, i.e. purchasing and logistics management, are covered by our certifications as listed in Table 18.

# Technical performance and principles of system design

## Sustainability (continued)

**Table 18 – Gyproc products and certifications at a glance**

Product Group	ISO 9001	ISO 14001	OHSAS 18001	BES 6001	ISO 50001
Gyproc standard performance plasterboards	✓	✓	✓	-	✓
Gyproc acoustic performance plasterboards	✓	✓	✓	-	✓
Gyproc fire performance plasterboards	✓	✓	✓	-	✓
Gyproc impact performance plasterboards	✓	✓	✓	-	✓
Gyproc moisture resistant plasterboards	✓	✓	✓	-	✓
Gyproc thermal performance plasterboards	✓	✓	✓	✓	✓
Gyproc fixings	-	-	-	-	✓
Gyproc decorative products – Cove / Cornice	✓	✓	✓	✓	✓
Gyproc decorative products – Styletrims	-	-	-	-	✓
Gyproc beads	-	-	-	-	✓
Gyproc accessories	✓	✓	-	-	✓
Gyproc accessories – Tape	-	-	-	-	-
Gyproc accessories – Sealant	-	-	-	-	-
Gyproc accessories – Control Joint	-	-	-	-	✓
Gyproc accessories – FireStrip	-	-	-	-	-
Gypframe studs	✓	✓	-	✓	✓
Gypframe channels	✓	✓	-	✓	✓
Gypframe steel angles	✓	✓	-	✓	✓
Gypframe specialist profiles	✓	✓	-	✓	✓
Gypframe clip, brackets & accessories	✓	✓	-	✓	✓
Rigitone tiles	✓	-	-	-	-
Gyptone boards – QUATTRO	-	-	-	-	-
Gyptone boards – SIXTO	✓	-	-	-	-
Gyptone Tiles and Planks	-	-	-	-	-
Gyprex	✓	✓	-	✓	-
Gyproc beads for solid plastering	-	-	-	-	✓
Gyproc plaster bonding agents	✓	-	-	-	-
Gyproc Hard Coat plaster	✓	✓	✓	✓	✓
Gyproc undercoat plasters	✓	✓	✓	-	✓
Gyproc finish coat plasters	✓	✓	✓	-	✓
Glasroc F fire protection boards	✓	✓	✓	✓	✓

**Table 19 – Gyproc’s raw materials**

Type	Description
Natural/Mined gypsum	The main raw material for most types of plaster and plasterboard is natural gypsum from our own mines. Gypsum mining is well established on a professional and environmentally sound basis as recycling optimises the use of limited natural resources and extends the life of mineral reserves. Our mines are certified to <i>ISO 14001:2004</i> and <i>ISO 9001:2008</i> . Our objective is to maintain 20 year reserve life for the Company and we have a rolling programme of investment to maintain this level of gypsum reserves.
DSG – Desulphogypsum	The main raw material for our UK manufactured plaster and plasterboard products is a recycled gypsum by-product formed during the ‘desulphurisation’ of flue gases at fossil fuel fired power stations (Drax and Ratcliffe on Soar, for example). This is known as DSG (desulphogypsum) or FGD (Flue Gas Desulphogypsum).
Recycled Plasterboard Off-Cuts	We are the only manufacturer in Ireland to offer a plasterboard off-cut recycling service. We will provide a Gyproc waste movement document to prove your plasterboard off-cuts are 100% recycled back into our plasterboard manufacturing process. For more information on this service please contact our Plasterboard Recycling Service (PRS) team at <a href="mailto:PRS.customerservice@saint-gobain.com">PRS.customerservice@saint-gobain.com</a> or call +353 (0)1 6298444.
Plasterboard liner	The liner used to sandwich gypsum to make plasterboard is made from various grades of paper, all of which is 100% post-consumer recycled material.

# Technical performance and principles of system design

## Sustainability (continued)

### Recycled content of our products

All recycled content figures are indicative, and give a fair statement of the normal situation but there is a certain amount of variation depending on demand for products and availability of feedstock at any given time. For the most up to date information please contact the Plasterboard Recycling Service (PRS) team:  
 Email: PRS.customerservice@saint-gobain.com  
 Tel: +353 (0) 1 6298444



**Table 20 – Gyproc products and recycled content at a glance**

Product group	Percentage post consumer	Percentage post industrial	Manufactured w/in 500 miles?	Contains raw materials extracted w/in 500 miles?	Material is recyclable?
Gyproc plasterboards	5.00% <sup>1</sup>	0.00%	Y	Y	100%
Gyproc fixings	25.00%	35.00%	N	N	100%
Gyproc beads	55.00%	0.00%	N	N	Y
Gyproc accessories	0.00%	0.00%	Y	Y	Y
Gypframe studs	55.00%	0.00%	Y	N	100%
Gypframe channels	55.00%	0.00%	Y	N	100%
Gypframe steel angles	55.00%	0.00%	Y	N	100%
Gypframe specialist profiles	55.00%	0.00%	Y	N	100%
Gypframe clip, brackets & accessories	55.00%	0.00%	Y	N	100%
Rigitone tiles	3.50%	84.00%	N	Y	100%
Gyptone boards	0.00%	75.00%	N	Y	100%
Gyptone Tiles and Planks	0.00%	75.00%	N	Y	100%
Gyprex	4.14%	95.86%	Y	Y	100%
Gyproc beads for solid plastering	55.00%	0.00%	Y	N	Y
Gyproc Finish Coat plasters	0.00%	0.00%	Y	Y	100%
Gyproc Undercoat plasters	0.00%	0.00%	Y	Y	100%
Gyproc Hard Coat plasters	0.00%	0.00%	Y	Y	100%
Glasroc F fire protection boards	1.30%	97.90%	Y	Y	100%
Glasroc F MULTIBOARD	0.00%	94.80%	Y	Y	100%
Rigidur	16.00%	20.00%	N	Y	100%
Glasroc H TILEBACKER	0.00%	94.10%	Y	Y	100%

### Explanatory Notes

**Post-consumer recycled content:** Portion of material or product which derives from discarded consumer waste that has been recovered for use as a raw material.

**Post-industrial recycled content:** Portion of material or product which derives from recovered industrial and manufacturing processes.

**Manufacture location:** If site is within the Republic of Ireland, this is typically an automatic YES. Note requirements for LEED v.4 have a 160km limit. Please verify your project location with the Gyproc Technical Department.

**Extraction location:** This is relative to the manufacture location, and is based on the majority of raw materials.

<sup>1</sup>Standard plasterboard

**NB** Some raw materials are imported; % addition rates fluctuate in accordance with availability and quality requirements. Metal recycled content is an average overall recycled content as received from the supplier.

# Technical performance and principles of system design

## Sustainability (continued)

### Indoor air quality

The current BREEAM schemes do not include plasterboard as a product category; there is no specific requirement to provide VOC content data. However, it can be relevant for post-construction testing requirements, as clients/specifiers may request this information from us. The standards used widely in Europe to evaluate VOC levels in plasterboard products are *EN 13419* and *ISO 16000*.

**Table 21 – Summary of indoor air quality parameters**

Product	VOCs	CFC & HCFC	GWP <sup>1</sup>	Comment
Gyproc plasterboard	-	Zero	Zero	Based upon indicative testing of a sample of plasterboard products, Gyproc plasterboard is estimated not to contain a VOC content or formaldehyde content which exceeds the requirements of European voluntary labelling schemes connected with indoor air quality.
Rigidur gypsum fibre boards	≤ 10 mg/m <sup>3</sup>	Zero	Zero	Emission test in compliance with the requirements following the testing scheme of the AgBB-version 2008 regarding all <i>DIN EN ISO 16000-9/-11</i> existing test points are met.
Gyproc Thermal laminate plasterboard	-	Zero	<5	
Gyproc plaster	-	Zero	Zero	None of the ingredients contained in the Gyproc range of undercoat and finishing plaster contain VOCs or formaldehyde which exceeds the requirements of European voluntary labelling schemes connected to indoor air quality.
ThistleBond-it	<5 g/l	Zero	Zero	
GypPrime	<3 g/l	Zero	Zero	
Gyproc Joint Filler	-	Zero	Zero	None of the ingredients contained in the Gyproc range of jointing materials contain VOCs or formaldehyde which exceeds the requirements of European voluntary labelling schemes connected to indoor air quality.
Gyproc Joint Cement	-	Zero	Zero	None of the ingredients contained in the Gyproc range of jointing materials contain VOCs or formaldehyde which exceeds the requirements of European voluntary labelling schemes connected to indoor air quality.
Gyproc Ready Mix Joint Cement	-	Zero	Zero	None of the ingredients contained in the Gyproc range of jointing materials contain VOCs or formaldehyde which exceeds the requirements of European voluntary labelling schemes connected to indoor air quality.
Gyproc Airtite Quiet	-	Zero	Zero	None of the ingredients contained in the Gyproc Airtite Quiet contain VOCs or formaldehyde which exceeds the requirements of European voluntary labelling schemes connected to indoor air quality.
Gyproc Plasterboard Compound	-	Zero	Zero	None of the ingredients contained in the Gyproc range of jointing materials contain VOCs or formaldehyde which exceeds the requirements of European voluntary labelling schemes connected to indoor air quality.
Gyproc Easi-Fill	-	Zero	Zero	Some of the ingredients for the product are known to contain trace elements of VOCs which are below the requirements of European voluntary labelling schemes connected to indoor air quality.
Gyproc Sealant	153.4 g/l	Zero	Zero	Gyproc Sealant contains VOCs. The 600ml cartridge contain 92.1 grams.
Gyproc Drywall Primer	<1g/l	Zero	Zero	-
Gyptone ceiling tiles	<1000µg/m <sup>3</sup>	Zero	Zero	Tested to <i>EN 13419-1 EN 13419-3</i> and <i>ISO16000-3</i> .
Gyprex SATINSPAR	-	Zero	Zero	None of the main components used in the manufacture of Gyprex SATINSPAR contain VOCs or formaldehyde which exceeds the requirements of European voluntary labelling schemes connected to indoor air quality.
Gyproc FireStrip	-	Zero	Zero	None of the main components used in the manufacture of Gyproc FireStrip contain VOCs or formaldehyde which exceeds the requirements of European voluntary labelling schemes connected to indoor air quality.
Gypframe	-	Zero	Zero	We currently do not have specific certification on the VOC content of our Gypframe product range. As far as we are aware our Gypframe products do not contain VOCs. The need for information on VOC content within BREEAM generally relates to surface finish products such as wall coverings and paints etc. and wood based products, and not the underlying drylining product / system.

<sup>1</sup> Global Warming Potential

# Assess for further locally supplied products

## Sustainability (continued)

### Life Cycle Assessment (LCA)

Across the construction industry there are many claims made regarding the environmental performance of products, and as such, it can be hard for specifiers to get a genuine picture of how sustainable a solution really is. LCA (Life Cycle Assessment) considers the entire life cycle of a product solution throughout its lifetime. As part of the assessment, a comprehensive range of factors are considered, including the potential environmental effects of raw materials, the manufacturing process, logistics, installation, performance in use and finally the product at the end of its life.

An Environmental Product Declaration (EPD) is a verified document that reports on the environmental data of products based on an LCA, as well as other relevant information in accordance with international standards such as *ISO 14025:2006 Type III Environmental Declarations* and *BS EN 15804: 2012 Sustainability of Construction Works. Environmental product declaration core rates for the product category of construction products*. Information such as raw material use, energy use and efficiency, content of materials and chemical substances, emissions to air, soil and water and waste generation can be viewed in an EPD.

The EPD results also enable us to understand at which stage our products have the greatest impact on the environment. We can therefore make better informed decisions on processes involved in the production of current and new products, as well as taking steps to minimise the environmental impact of our products across their lifecycle.

EPD also provide clear evidence for environmental building certification schemes, meeting credit requirements in BREEAM, for example.

Generic LCA have been carried out in the past for plasterboard products – including, one carried out by the Building Research Establishment (BRE), on which the current Green Guide rankings are based and another was conducted by Waste and Resources Action Programme (WRAP) and is available to download from their website: [wrap.org.uk](http://wrap.org.uk)

Professor Geoffrey Hammond and Craig Jones from the Department of Mechanical Engineering at the University of Bath have developed an 'Inventory of Carbon & Energy' (ICE) – a database for embodied energy and carbon emissions associated with a wide range of materials. This can be found online at: [www.circularecology.com/embodied-energy-and-carbon-footprint-database.html](http://www.circularecology.com/embodied-energy-and-carbon-footprint-database.html)

We want to make the selection of sustainable solutions simpler for our customers. In order to do this we have begun developing Life Cycle Assessments (LCA) for our product ranges. The independently verified EPD, which are the result of the Life Cycle Assessment (LCA) process, are designed to

give users information on the environmental performance of our products across numerous impact categories.

Our current completed EPDs are for:

- Gyproc Finish Plaster
- Gyproc Hard Coat
- 12.5mm WallBoard
- 12.5mm FireLine
- 6mm Glasroc F MULTIBOARD
- 15mm Glasroc F FIRECASE
- 12.5mm Glasroc H TILEBACKER
- 12.5mm Gyptone Big Activ'Air®
- 10mm Gyptone Ceiling Tiles Activ'Air®
- Gypframe Metal Components

This is just the beginning of the journey. We are developing further EPD for our solutions and these will be rolled out in due course. All current EPD can be found on our website [gyproc.ie](http://gyproc.ie)

Our sister company Rigips, located in Germany have had assessments carried out on our Rigidur product. The EPD for this product can be found on the Rigips website [rigips.de/download/Environmental\\_Product\\_Declaration\\_Rigidur.pdf](http://rigips.de/download/Environmental_Product_Declaration_Rigidur.pdf)

#### Useful links

##### Gyproc – sustainability

[www.gyproc.ie/about-gyproc/sustainability](http://www.gyproc.ie/about-gyproc/sustainability)  
[www.gyproc.ie/resources](http://www.gyproc.ie/resources)

##### Building Regulations

[www.environ.ie/housing/building-standards/building-standards](http://www.environ.ie/housing/building-standards/building-standards)  
[www.buildingcontrol-ni.com/regulations/technical-booklets](http://www.buildingcontrol-ni.com/regulations/technical-booklets)

##### BREEAM

[breeam.org](http://breeam.org)

##### Irish Green Building Council Home Performance Index

[www.igbc.ie/certification/home-quality-rating/](http://www.igbc.ie/certification/home-quality-rating/)

##### Green Guide

[bre.co.uk/greenguide](http://bre.co.uk/greenguide)

##### LEED

[usgbc.org/leed](http://usgbc.org/leed)



# C03

Steel encasements

## Steel encasements

This section contains steel encasement systems that provide up to 180 minutes of fire protection to structural steel columns and 120 minutes for structural steel beams and joists



# Steel encasements

Passive fire protection is a vital component of any fire safety strategy. It safeguards people's lives and limits the financial impact of damage to buildings and their contents. The protection of the superstructure from fire is especially important, as once its integrity is compromised, the whole building's stability will be at risk.

We have two types of solution:

- **FireCase** – C03. S02. P71  
A frameless structural steel encasement where the board linings are fixed to themselves to minimise space intrusion. The system can be used in buildings before they are fully watertight to improve speed of project handover
- **GyLyner ENCASE** – C03. S03. P91  
A metal framed structural steel encasement system for greater flexibility of installation

Each system section takes you through the process of selecting the required lining type and thickness to provide a range of standard structural steel beam, column and joist sizes with the fire protection level needed.

Both systems are able to accept standard methods of finishing; tape and joint or Gyproc Finish Plaster, to aesthetically match surrounding elements. An aesthetic finish is not necessary with the **FireCase** system to maintain its fire performance.



## You may also be interested in...

If you need to protect structural steel within the cavity,

- ▶ Refer to **GypWall QUIET C04. S07. P219** or **GypWall QUIET IWL C04. S08. P231**



### Areas to consider when specifying

Unlike some alternative fire protection technologies, for example intumescent paint, our encasement systems will give acoustic benefits by reducing sound transmission through the steelwork. Further improvements can be made to the sound insulation performance by the inclusion of Isover insulation within the system, and by modifying the abutment detailing to reduce flanking sound transmission.

► Refer to figure 1.

Using **FireCase** or **GyLyner ENCASE** could therefore offer both savings and simplification over alternative fire protection technologies that may require overboarding.

### Thickness of applied fire protection

Glasroc F **FIRECASE** and Gyproc plasterboards are manufactured to stringent factory tolerances, giving the client peace of mind that the correct thickness of fire protection has been applied, ensuring life safety in the event of a fire.

### Benefits to compartmentation

Using the **FireCase** or the **GyLyner ENCASE** systems will eliminate any potential problems with compartmentation. Unlike some alternative fire protection technologies, e.g. paint, using the **FireCase** or **GyLyner ENCASE** systems will ensure that there are no potential problems with insulation failure through the steelwork.

Our technical teams can provide guidance on fire resistance performance using Gyproc steel encasement systems, depending on the specific fire protection and fire resistance requirements. All systems will require taping and jointing as part of these opinions.

► Refer to figure 2.

### All year round installation

Glasroc F **FIRECASE** and Gyproc plasterboards have an operational tolerance from below freezing to +49°C, whereas some alternative technologies are often +5°C to +30°C. This ensures that there are no potential problems with the build program in Irish winter conditions.

### Building programme efficiencies

The **FireCase** and **GyLyner ENCASE** systems allow other trades to work in close proximity and simultaneously. Some alternative technologies require areas of the site to be closed off due to the containment of overspray and fumes.

### Ease of maintenance

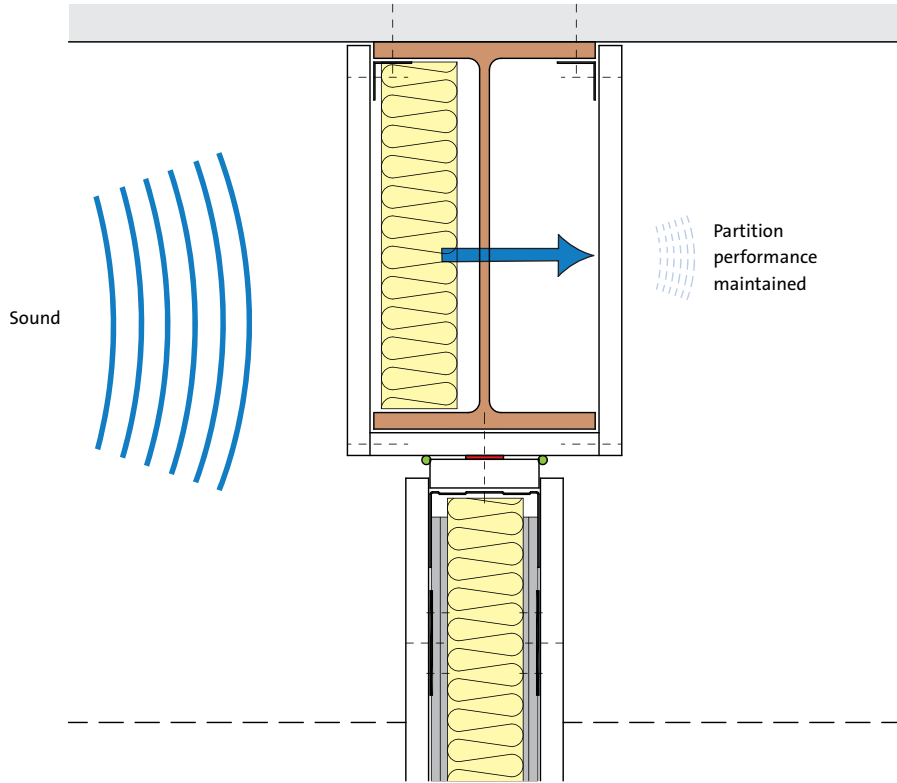
Using the Fire Services Acts 1981 & 2003 and the Fire Safety Regulations (Northern Ireland) 2010 the responsible person has duty of care for maintaining the buildings fire protection systems. The **FireCase** and **GyLyner ENCASE** systems are robust but should damage occur it is easy to identify and simple to repair or replace, making management and maintenance simple for building owners.



### Additional information

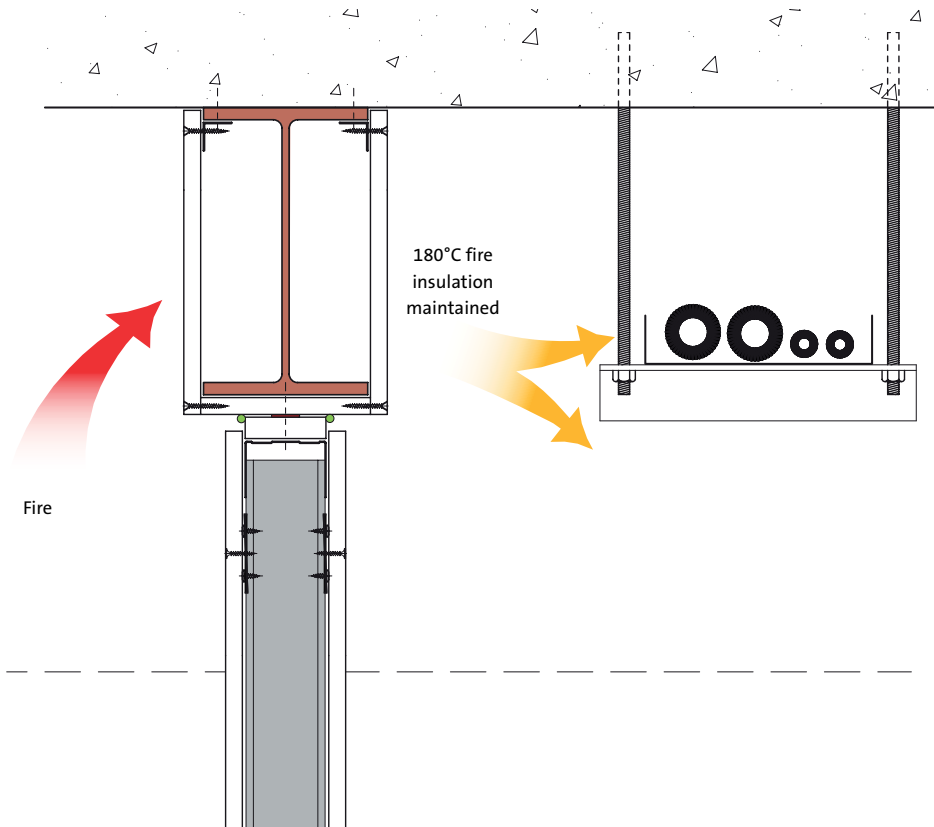
Try out our **System Selector**, an online tool designed to help find the ideal solutions for your project needs. Visit [gyproc.ie](http://gyproc.ie)

1



Benefit to acoustics -  
Fire resistance in accordance with BS 476 Part 22: 1987

2



Benefits of compartmentation - BS 476 Part 22: 1987  
Steel encasement system to be taped and jointed to offer compartmentation

# FireCase

Frameless structural steel encasement system that provides up to 120 minutes fire protection



# FireCase

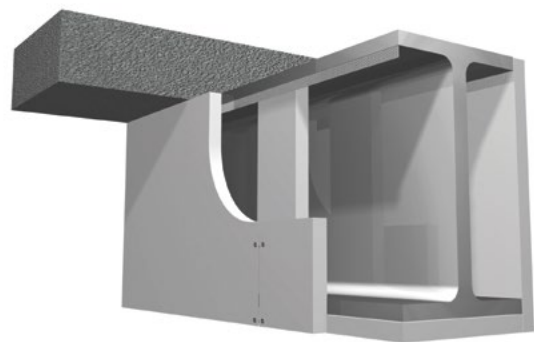
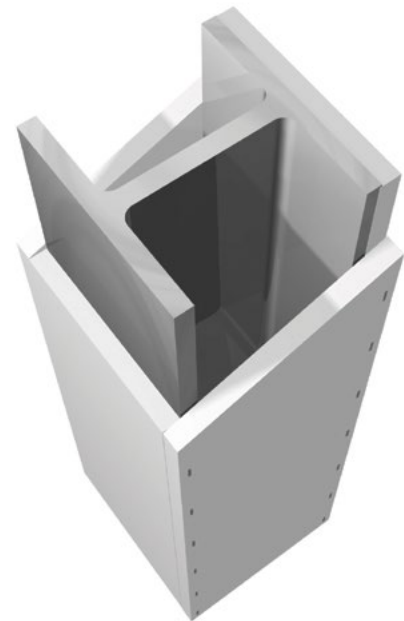
**FireCase** is a frameless structural steel encasement system that provides up to 120 minutes fire protection to a wide range of universal beam, column and joist sizes. Installation is quick and easy owing to the ability to fix Glasroc F FIRECASE boards to one another without the need for additional framing.



The Glasroc F FIRECASE lining provides a smooth, robust surface with no requirement to joint or apply a decorative treatment.

## Key benefits

- Frameless system that minimises the space needed to provide fire protection to structural steel
- Reduced installation time as Glasroc F FIRECASE boards can be screw-fixed to one another without the need for other components
- Build-programme flexibility and earlier installation as the inherent moisture resistance capability of Glasroc F FIRECASE means that installation of the FireCase system can commence before the building envelope is fully weather tight
- FireCase system is easy to inspect for continuity when compared to intumescent paint solutions, giving greater peace of mind both immediately after installation and during maintenance inspections
- Reduced waste and labour onsite as bespoke, pre-cut widths of Glasroc F FIRECASE are available (subject to minimum order quantity)
- High levels of acoustic insulation, in addition to excellent fire protection performance, can be maintained with appropriate detailing to the abutments between GypWall partition systems and FireCase steel encasements
- British Board of Agrément (BBA) approved (93/2935)



## Planning – key factors

FireCase steel encasement is suitable for protecting structural steel sections with a section factor  $A/V$  ( $H_p/A$ ) up to  $260\text{m}^{-1}$ , calculated on the basis of box protection to three or four sides as required. It will protect universal column and beam sections described in *BS 4: Part 1*, and many joist and castellated beam sections.

## Lining selection

Follow the procedure below to determine the thickness of cladding required:

### Option 1

Use tables 2 - 4 to select steel size and fire protection then read off the required board size.

### Option 2

- 1 Ascertain whether protection is required on three or four sides of the section
- 2 Find out what period of fire protection is required
- 3 Refer to the  $A/V$  ( $H_p/A$ ) tables 5 - 7. Locate the steel section to be protected, listed by its size and mass per metre, and read off the section factor  $A/V$
- 4 Refer to tables 8 - 11. Locate the  $A/V$  value on the vertical scale on the appropriate table. Read across the chart to the column relating to the period of fire protection required and read off the designated thickness of the relevant cladding required to form the encasement
- 5 Select the type of board to be using the key below each table

For castellated sections and cellular beams please refer to the Association for Specialist Fire Protection publication, ASFP Yellow Book - 'Fire Protection for Structural Steel in buildings' for guidance, available to download from [asfp.org.uk](http://asfp.org.uk)

## Partition fixing

Partitions and wall linings may be fixed directly to the Glasroc F FIRECASE cladding as long as:

- 1 The fire resistance requirement of the partition is 60 minutes or less
- 2 There are no special requirements for pressure resistance, e.g. around lift shafts
- 3 There are no special loading requirements, i.e. Heavy Duty or Severe Duty as defined in recognised partition performance specifications (e.g. *BS 5234*)

► Refer to construction detail 9.

Where these criteria are not met, the partition framing must be suitably fixed to the structural steel section, through the Glasroc F FIRECASE cladding. Where the partition abuts the web of the structural steel, a suitable steel noggling must be provided.

► Refer to construction detail 10.

## Partition to structural steelwork junctions

When designing the layout of rooms requiring separation by sound insulating walls abutting structural steelwork, consideration should be given to the potential loss of sound insulation performance through the steelwork.

Figures 13 to 16 are example details relating to a typical scenario where a partition is specified against a requirement of  $R_w$  50dB. Although these details refer to structural steel column abutments, similar principles apply when abutting structural steel beams. We recommend that these details are checked by an Acoustic Consultant, in particular the performance via the flanking structure.

## Finishing

Glasroc F FIRECASE joints can be treated using Gyproc Joint Tape bedded in Gyproc Joint Cement. External angles / corners can be reinforced using Gyproc Drywall Metal Angle Bead bedded in Gyproc Joint Cement.

► Refer to C08. S03. P492 – Finishes, Jointing.

If a plaster finish is required, joints should be reinforced and Gyproc Finish Plaster applied.

► Refer to C08. S02. P486 – Finishes, Plaster skimming and C07. S02. P459 – Linings, Plaster systems.

Jointing and finishing is not a requirement of meeting the specified fire resistance. Board joints / abutments must be a flush fit.



## Important information

- Where steel section web dimensions exceed 600mm, additional support will be required for the cladding. Please contact the Gyproc Technical Department for guidance.
- All joints should be staggered by minimum of 600mm.

**Table 1 – Specialist board fixings**

Board thickness (mm)	Minimum fixing length	
	Board-to-board fixing	Board-to-metal fixing
15	40mm Glasroc F FIRECASE Screws	40mm Glasroc F FIRECASE Screws
20	50mm Glasroc F FIRECASE Screws	40mm Glasroc F FIRECASE Screws
25	58mm Glasroc F FIRECASE Screws	40mm Glasroc F FIRECASE Screws
30	70mm Glasroc F FIRECASE Screws	40mm Glasroc F FIRECASE Screws
15 + 20	40mm and 50mm Glasroc F FIRECASE Screws	40mm and 50mm Glasroc F FIRECASE Screws



### Important information

Where partitions abut a FireCase column or beam encasement and it is important to minimise the downgrade in acoustic performance, use either:

- Isover insulation within the web space
  - ▶ Refer to construction details 14 and 15; or
- Additional framing, Isover insulation and Gyproc plasterboard lining
  - ▶ Refer to construction detail 16

## FireCase design (continued)

For details of when  
to specify fire  
resistance using BS  
▶ Refer to C02. S01. P18



**Table 2 – 550°C chart to BS 476: Part 20 for selecting the required Glasroc F FIRECASE lining thickness for universal beam sizes**

Universal beam serial size of steel (mm x mm x kg/m)			Total Glasroc F FIRECASE board thickness (mm) to achieve fire resistance below <sup>1</sup>							
D	B	Mass/metre	3 sided encasement				4 sided encasement			
			30 min	60 min	90 min	120 min	30 min	60 min	90 min	120 min
1016	305	487	15	15	15	15	15	15	15	15
	305	438	15	15	15	15	15	15	15	15
	305	393	15	15	15	15	15	15	15	15
	305	349	15	15	15	15	15	15	15	15
	305	314	15	15	15	15	15	15	15	15
	305	272	15	15	15	15	15	15	15	20
	305	249	15	15	15	20	15	15	15	20
	305	222	15	15	15	20	15	15	15	20
914	419	388	15	15	15	15	15	15	15	15
	419	343	15	15	15	15	15	15	15	15
	305	289	15	15	15	15	15	15	15	15
	305	253	15	15	15	15	15	15	15	20
	305	224	15	15	15	20	15	15	15	20
	305	201	15	15	15	20	15	15	15	25
838	292	226	15	15	15	20	15	15	15	20
	292	194	15	15	15	20	15	15	15	20
	292	176	15	15	15	20	15	15	15	25
762	267	197	15	15	15	20	15	15	15	20
	267	173	15	15	15	20	15	15	15	25
	267	147	15	15	15	25	15	15	20	30
	267	134	15	15	15	25	15	15	20	30
686	254	170	15	15	15	20	15	15	15	20
	254	152	15	15	15	20	15	15	15	25
	254	140	15	15	15	20	15	15	15	25
	224	125	15	15	15	25	15	15	20	30
610	305	238	15	15	15	15	15	15	15	15
	305	179	15	15	15	20	15	15	15	20
	305	149	15	15	15	20	15	15	15	25
	229	140	15	15	15	20	15	15	15	25
	229	125	15	15	15	20	15	15	15	25
	229	113	15	15	15	25	15	15	20	30
	229	101	15	15	20	30	15	15	20	30
	178	100	15	15	20	30	15	15	20	30
	178	92	15	15	20	30	15	15	20	30
	178	82	15	15	20	30	15	15	20	30
	533	312	273	15	15	15	15	15	15	15
312		219	15	15	15	15	15	15	15	15
312		182	15	15	15	15	15	15	15	20
312		151	15	15	15	20	15	15	15	20
210		138	15	15	15	20	15	15	15	20
210		122	15	15	15	20	15	15	15	25
210		109	15	15	15	25	15	15	20	30
210		101	15	15	15	25	15	15	20	30
210		92	15	15	20	30	15	15	20	30
210		82	15	15	20	30	15	15	20	30
165		85	15	15	20	30	15	15	20	30
165		75	15	15	20	30	15	15	20	30
165		66	15	15	20	30	15	15	20	30

<sup>1</sup>Glasroc F FIRECASE thickness combinations:

- 15mm = 1 x 15mm
- 20mm = 1 x 20mm
- 25mm = 1 x 25mm
- 30mm = 1 x 30mm
- 35mm = 1 x 15mm + 1 x 20mm

System references: D120001 (screwed system)

Beam/column/joist dimension orientation:

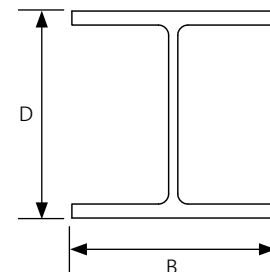




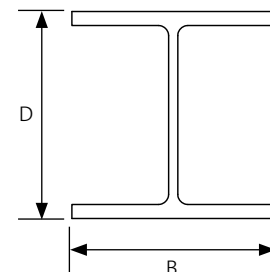
Table 2 (continued) – 550°C chart to BS 476: Part 20 for selecting the required Glasroc F FIRECASE lining thickness for universal beam sizes

Universal beam serial size of steel (mm x mm x kg/m)			Total Glasroc F FIRECASE board thickness (mm) to achieve fire resistance below <sup>1</sup>							
D	B	Mass/metre	3 sided encasement				4 sided encasement			
			30 min	60 min	90 min	120 min	30 min	60 min	90 min	120 min
457	191	161	15	15	15	15	15	15	15	15
	191	133	15	15	15	20	15	15	15	20
	191	106	15	15	15	20	15	15	15	25
	191	98	15	15	15	20	15	15	15	25
	191	89	15	15	15	25	15	15	20	30
	191	82	15	15	15	25	15	15	20	30
	191	74	15	15	20	30	15	15	20	30
	191	67	15	15	20	30	15	15	20	30
	152	82	15	15	15	25	15	15	20	30
	152	74	15	15	20	30	15	15	20	30
	152	67	15	15	20	30	15	15	20	30
	152	60	15	15	20	30	15	15	20	30
	152	52	15	15	20	30	15	15	20	30
	406	178	85	15	15	15	25	15	15	20
178		74	15	15	15	25	15	15	20	30
178		67	15	15	20	30	15	15	20	30
178		60	15	15	20	30	15	15	20	30
178		54	15	15	20	30	15	15	20	30
140		53	15	15	20	30	15	15	20	30
140		46	15	15	20	30	15	15	25	30
140		39	15	15	25	30	15	15	25	30
356	171	67	15	15	15	25	15	15	20	30
	171	57	15	15	20	30	15	15	20	30
	171	51	15	15	20	30	15	15	20	30
	171	45	15	15	20	30	15	15	20	30
	127	39	15	15	20	30	15	15	25	30
	127	33	15	15	25	30	15	15	25	30
305	165	54	15	15	20	30	15	15	20	30
	165	46	15	15	20	30	15	15	20	30
	165	40	15	15	20	30	15	15	25	30
	127	48	15	15	20	30	15	15	20	30
	127	42	15	15	20	30	15	15	20	30
	127	37	15	15	20	30	15	15	20	30
	102	33	15	15	20	30	15	15	25	30
	102	28	15	15	25	30	15	15	25	30
	102	25	15	15	25	30	15	15	25	35
	254	146	43	15	15	20	30	15	15	20
146		37	15	15	20	30	15	15	20	30
146		31	15	15	20	30	15	15	25	30
102		28	15	15	20	30	15	15	25	30
102		25	15	15	25	30	15	15	25	30
102		22	15	15	25	30	15	15	25	35
203	133	30	15	15	20	30	15	15	20	30
	133	25	15	15	20	30	15	15	25	30
	102	23	15	15	20	30	15	15	25	30
178	102	19	15	15	25	30	15	15	25	30
152	89	16	15	15	25	30	15	15	25	30
127	76	13	15	15	25	30	15	15	25	30

<sup>1</sup>Glasroc F FIRECASE thickness combinations:

- 15mm = 1 x 15mm
- 20mm = 1 x 20mm
- 25mm = 1 x 25mm
- 30mm = 1 x 30mm
- 35mm = 1 x 15mm + 1 x 20mm

Beam/column/joist dimension orientation:



System references: D120001 (screwed system)



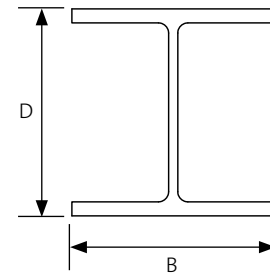
Table 3 – 550°C chart to BS 476: Part 20 for selecting the required Glasroc F FIRECASE lining thickness for universal column sizes

Universal column serial size of steel (mm x mm x kg/m)			Total Glasroc F FIRECASE board thickness (mm) to achieve fire resistance below <sup>1</sup>							
			3 sided encasement				4 sided encasement			
D	B	Mass/metre	30 min	60 min	90 min	120 min	30 min	60 min	90 min	120 min
356	406	634	15	15	15	15	15	15	15	15
	406	551	15	15	15	15	15	15	15	15
	406	467	15	15	15	15	15	15	15	15
	406	393	15	15	15	15	15	15	15	15
	406	340	15	15	15	15	15	15	15	15
	406	287	15	15	15	15	15	15	15	15
	406	235	15	15	15	15	15	15	15	15
	368	202	15	15	15	15	15	15	15	15
	368	177	15	15	15	15	15	15	15	15
	368	153	15	15	15	15	15	15	15	20
368	129	15	15	15	15	15	15	15	20	
305	305	283	15	15	15	15	15	15	15	15
	305	240	15	15	15	15	15	15	15	15
	305	198	15	15	15	15	15	15	15	15
	305	158	15	15	15	15	15	15	15	15
	305	137	15	15	15	15	15	15	15	20
	305	118	15	15	15	15	15	15	15	20
	305	97	15	15	15	20	15	15	15	25
254	254	167	15	15	15	15	15	15	15	15
	254	132	15	15	15	15	15	15	15	15
	254	107	15	15	15	15	15	15	15	20
	254	89	15	15	15	20	15	15	15	20
	254	73	15	15	15	20	15	15	20	30
203	203	127	15	15	15	15	15	15	15	15
	203	113	15	15	15	15	15	15	15	15
	203	100	15	15	15	15	15	15	15	20
	203	86	15	15	15	15	15	15	15	20
	203	71	15	15	15	20	15	15	15	25
	203	60	15	15	15	20	15	15	20	30
	203	52	15	15	15	25	15	15	20	30
	203	46	15	15	15	25	15	15	20	30
152	152	51	15	15	15	20	15	15	15	25
	152	44	15	15	15	20	15	15	20	30
	152	37	15	15	15	25	15	15	20	30
	152	30	15	15	20	30	15	15	20	30
	152	23	15	15	20	30	15	15	25	30

<sup>1</sup>Glasroc F FIRECASE thickness combinations:

- 15mm = 1 x 15mm
- 20mm = 1 x 20mm
- 25mm = 1 x 25mm
- 30mm = 1 x 30mm
- 35mm = 1 x 15mm + 1 x 20mm

Beam/column/joist dimension orientation:



System references: D120001 (screwed system)



Table 4 – 550°C chart to BS 476: Part 20 for selecting the required Glasroc F FIRECASE lining thickness for universal joist sizes

Universal joist serial size of steel (mm x mm x kg/m)			Total Gyproc F FIRECASE board thickness (mm) to achieve fire resistance below <sup>1</sup>							
			3 sided encasements				4 sided encasements			
D	B	Mass/metre	30 min	60 min	90 min	120 min	30 min	60 min	90 min	120 min
254	203	82	15	15	15	20	15	15	15	25
	114	37	15	15	20	30	15	15	20	30
203	152	52	15	15	15	20	15	15	20	25
	102	25	15	15	20	30	15	15	25	30
178	102	22	15	15	20	30	15	15	25	30
152	127	37	15	15	15	30	15	15	20	30
	89	17	15	15	25	30	15	15	25	30
	76	18	15	15	20	30	15	15	25	30
127	114	30	15	15	15	25	15	15	20	30
	114	27	15	15	20	30	15	15	20	30
	76	16	15	15	20	30	15	15	25	30
	76	13	15	15	25	30	15	15	25	30
114	114	27	15	15	15	25	15	15	20	30
102	102	23	15	15	20	25	15	15	20	30
	64	10	15	15	25					
	44	7	15	15	25					
89	89	19	15	15	20	25	15	15	20	30
76	76	15	15	15	20	30	15	15	20	30
	76	13	15	15	20	30	15	15	25	30

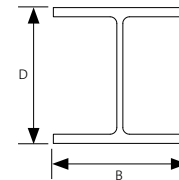
<sup>1</sup> Glasroc F FIRECASE thickness combinations

- 15mm = 1 x 15mm
- 20mm = 1 x 20mm
- 25mm = 1 x 25mm
- 30mm = 1 x 30mm
- 35mm = 1 x 15mm + 1 x 20mm

- protection not possible

System references: D120001  
(screwed system)

Beam/column/joist dimension orientation:



## FireCase design (continued)

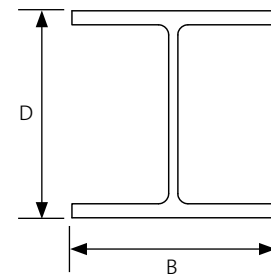
Table 5 – Section factor A/V (Hp/A) of universal beams

Universal beams serial size of steel (mm x mm x kg/m)			A / V Values		
D	B	Mass/metre	3 sided encasement	4 sided encasement	
1016	305	487	40	45	
	305	438	40	50	
	305	393	45	55	
	305	349	50	60	
	305	314	55	65	
	305	272	65	75	
	305	249	70	80	
	305	222	80	90	
914	419	388	45	55	
	419	343	50	60	
	305	289	60	65	
	305	253	65	75	
	305	224	75	85	
838	292	226	70	80	
	292	194	80	90	
	292	176	90	100	
762	267	197	70	85	
	267	173	80	95	
	267	147	95	110	
	267	134	105	120	
686	254	170	75	90	
	254	152	85	95	
	254	140	90	105	
	254	125	100	115	
610	305	238	50	60	
	305	179	70	80	
	305	149	80	95	
	229	140	80	95	
	229	125	90	105	
	229	113	100	115	
	229	101	110	130	
	178	100	110	125	
	178	92	120	135	
	178	82	130	150	
	533	312	273	40	50
		312	219	50	65
		312	182	60	75
312		151	75	90	
210		138	75	85	
210		122	85	95	
210		109	95	110	
210		101	100	115	
210		92	110	125	
210		82	120	140	
165		85	115	130	
165		75	130	145	
165		66	145	165	

Table 5 (continued) – Section factor A/V (Hp/A) of universal beams

Universal beams serial size of steel (mm x mm x kg/m)			A / V Values		
D	B	Mass/metre	3 sided encasement	4 sided encasement	
457	191	161	60	65	
	191	133	70	80	
	191	106	85	100	
	191	98	90	105	
	191	89	100	115	
	191	82	105	125	
	191	74	115	135	
	191	67	130	150	
	152	82	105	120	
	152	74	115	130	
	152	67	125	145	
	152	60	140	160	
	152	52	160	180	
	406	178	85	95	110
178		74	105	125	
178		67	115	140	
178		60	130	155	
178		54	145	170	
140		53	140	160	
140		46	160	185	
140		39	190	215	
356		171	67	105	125
		171	57	120	145
	171	51	135	160	
	171	45	150	180	
	127	39	165	195	
	127	33	195	225	
	305	165	54	115	140
165		46	135	160	
165		40	150	185	
127		48	120	145	
127		42	140	160	
127		37	155	180	
102		33	175	200	
102		28	200	230	
102		25	225	255	
254		146	43	120	150
	146	37	140	170	
	146	31	165	200	
	102	28	175	200	
	102	25	190	225	
	102	22	220	255	
	203	133	30	145	180
133		25	170	210	
102		23	175	205	
178		19	190	230	
152	89	16	195	235	
127	76	13	200	245	

Beam/column/joist dimension orientation:



You may also be interested in...



Need 180mins fire protection? If so, consider the Gypliner ENCASE system.

► Refer to C03. S03. P99

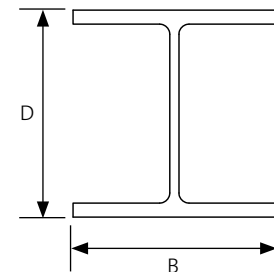
Table 6 – Section factor A/V (Hp/A) of universal columns

Universal columns serial size of steel (mm x mm x kg/m)			A / V Values		
D	B	Mass/metre	3 sided encasement m <sup>-1</sup>	4 sided encasement m <sup>-1</sup>	
356	406	634	15	20	
	406	551	20	25	
	406	467	20	30	
	406	393	25	35	
	406	340	30	35	
	406	287	30	45	
	406	235	40	50	
	368	202	45	60	
	368	177	50	65	
	368	153	55	75	
	368	129	65	90	
	305	305	283	30	40
305		240	35	45	
305		198	40	50	
305		158	50	65	
305		137	55	70	
305		118	60	85	
305		97	75	100	
254		254	167	40	50
	254	132	50	65	
	254	107	60	75	
	254	89	70	90	
	254	73	80	110	
	203	203	127	45	55
203		113	45	60	
203		100	55	70	
203		86	60	80	
203		71	70	95	
203		60	80	110	
203		52	95	125	
203		46	105	140	
152		152	51	75	100
		152	44	85	115
	152	37	100	135	
	152	30	120	160	
	152	23	155	210	

Table 7 – Section factor A/V (Hp/A) of universal joist

Universal joist serial size of steel (mm x mm x kg/m)			A / V Values	
D	B	Mass/metre	3 sided encasement m <sup>-1</sup>	4 sided encasement m <sup>-1</sup>
254	203	82	70	90
	114	37	130	155
203	152	52	85	105
	102	25	155	190
178	102	22	165	205
152	127	37	90	120
	89	17	180	220
	76	18	165	200
127	114	30	100	130
	114	27	110	140
	76	16	155	195
	76	13	195	240
	114	114	27	100
102	102	23	105	140
	64	10	215	270
89	44	7	260	305
89	89	19	105	145
76	76	15	120	165
76	76	13	140	185

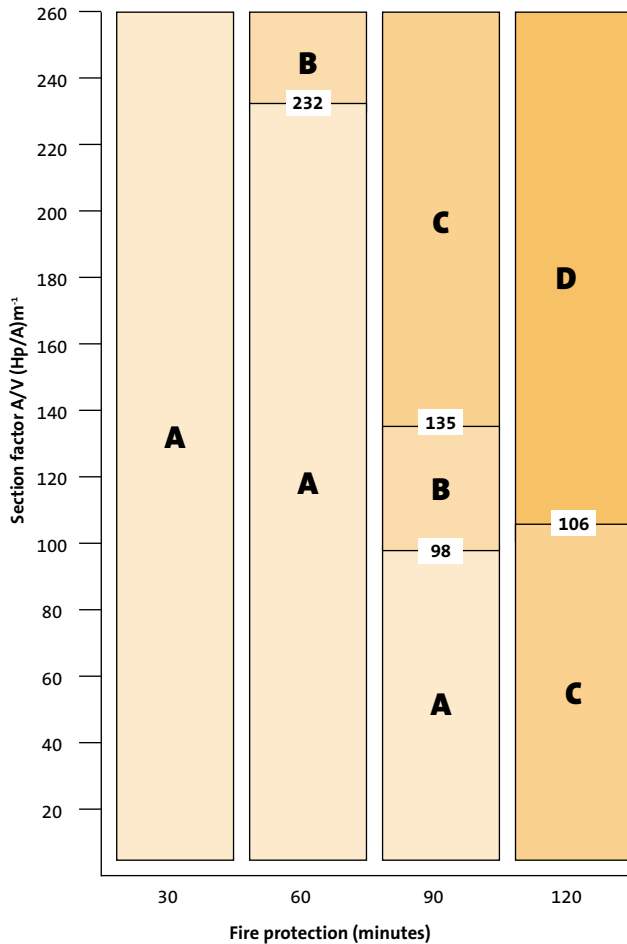
Beam/column/joist dimension orientation:



# FireCase performance



**Table 8**  
Solutions to satisfy the 550°C criteria when tested in accordance with *BS EN 13381-4: 2013* (four-sided columns only)  
▶ Refer to C02. S01. P18



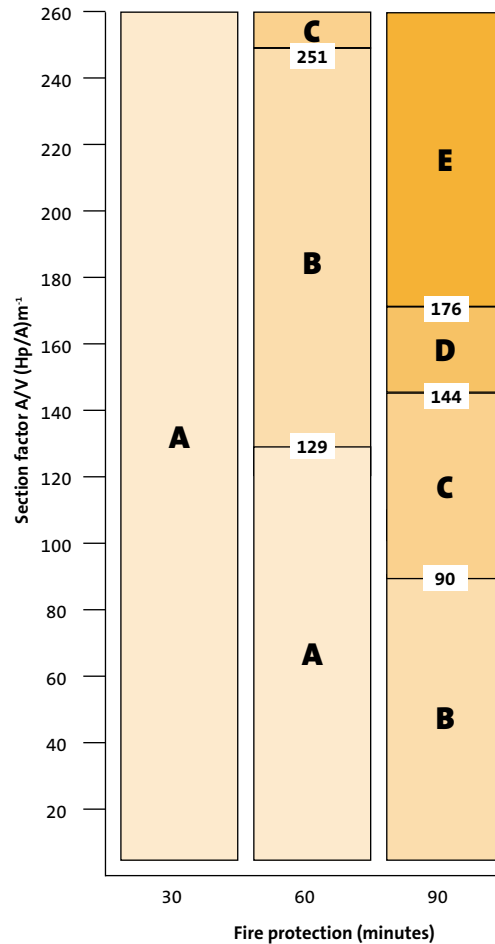
### Key - Thickness of Glasroc F FIRECASE required

A = 15mm  
B = 20mm  
C = 25mm  
D = 30mm

System references: D120001 (screwed system)



**Table 9**  
Solutions to satisfy the 550°C criteria when tested in accordance with *BS EN 13381-4: 2013* (three-sided beams only)  
▶ Refer to C02. S01. P18



### Key - Thickness of Glasroc F FIRECASE required

A = 15mm  
B = 20mm  
C = 25mm  
D = 30mm  
E = 35mm (15 + 20mm)

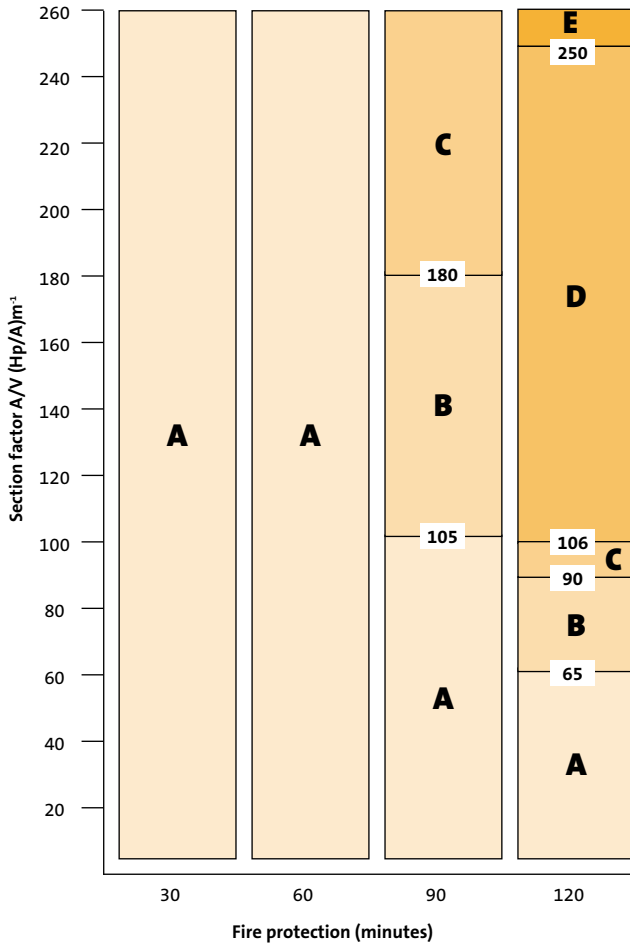
System references: D120001 (screwed system)



**Table 10**  
Solutions to satisfy the 550°C criteria when tested in accordance with BS 476: Part 20: 1987 (beam and column encasement)  
▶ Refer to C02. S01. P18



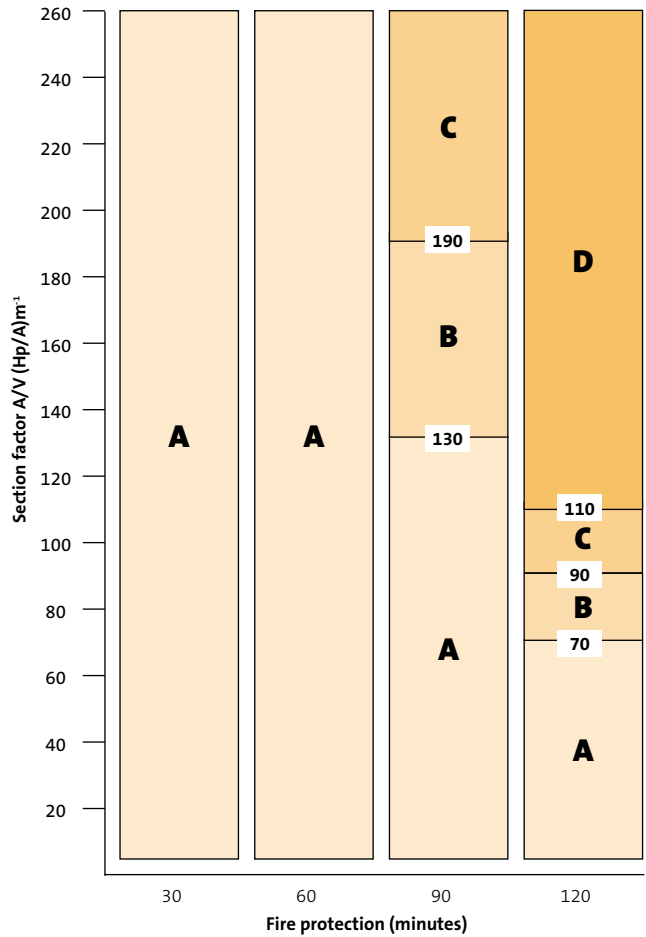
**Table 11**  
Solutions to satisfy the 620°C criteria when tested in accordance with BS 476: Part 20: 1987 (beam and column encasement)  
▶ Refer to C02. S01. P18



**Key - Thickness of Glasroc F FIRECASE required**

- A = 15mm
- B = 20mm
- C = 25mm
- D = 30mm
- E = 35mm (15mm + 20mm)

System references: D120001 (screwed system)



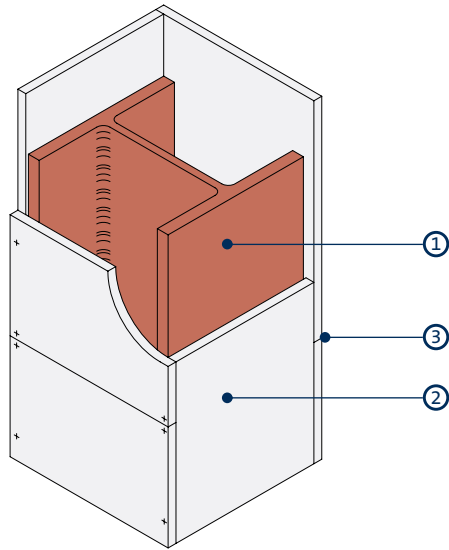
**Key - Thickness of Glasroc F FIRECASE required**

- A = 15mm
- B = 20mm
- C = 25mm
- D = 30mm

System references: D120001 (screwed system)

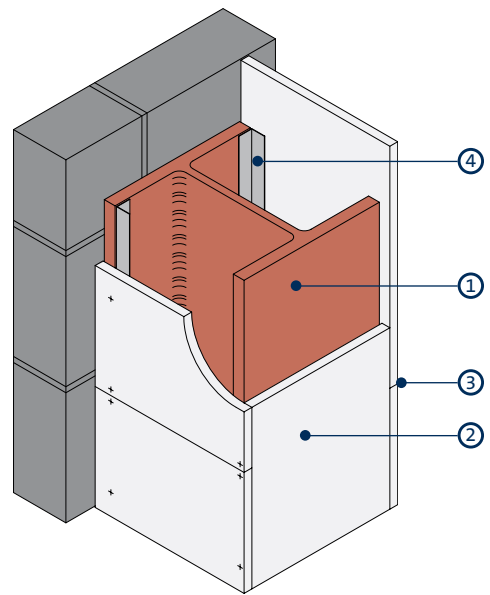
## FireCase construction details

1



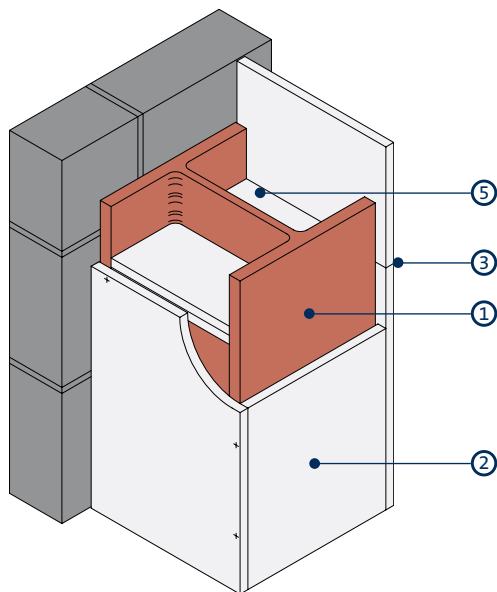
Four-sided column encasement for up to 120 minutes fire protection

2



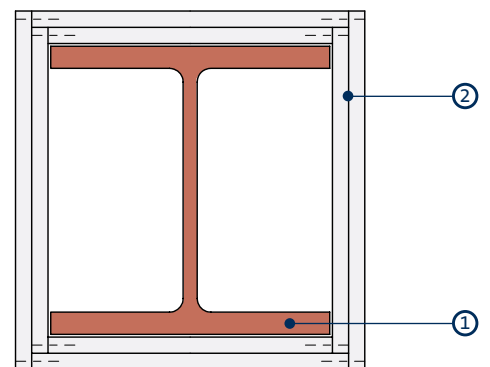
Three-sided column encasement incorporating steel angles for up to 120 minutes fire protection

3



Three-sided column encasement incorporating Glasroc F FIRECASE soldiers for up to 90 minutes fire protection

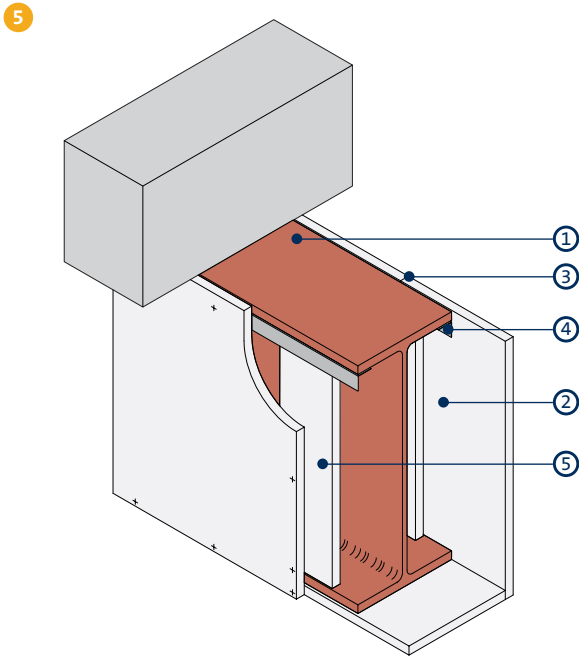
4



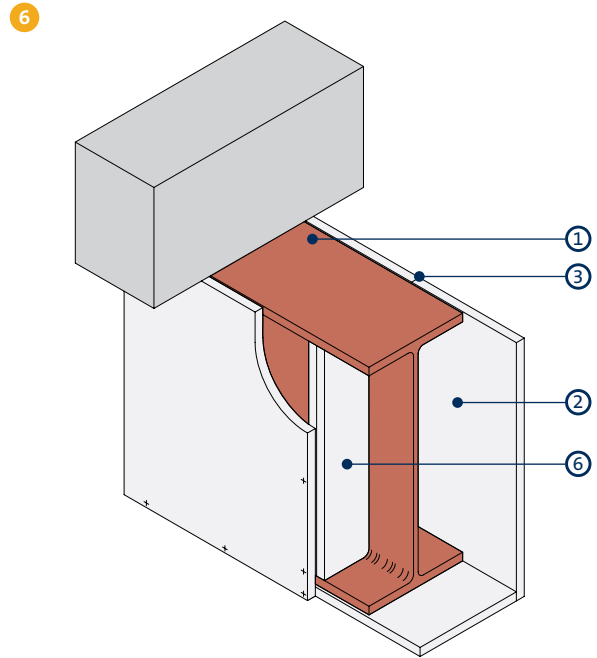
Four-sided column encasement for up to 120 minutes fire protection - double layer

- 1 Structural steel
- 2 Glasroc F FIRECASE fixed together with Glasroc F FIRECASE Screws at 150mm centres
- 3 Board joints staggered by minimum 600mm between adjacent sides

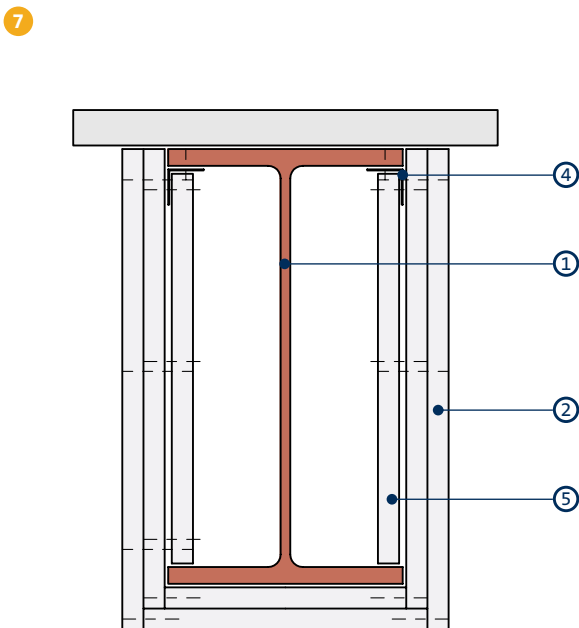
- 4 Gypframe FEA1 Steel Angle suitably fixed to column flange at 600mm centres
- 5 Glasroc F FIRECASE soldiers at 1200mm centres (two together at board joints)



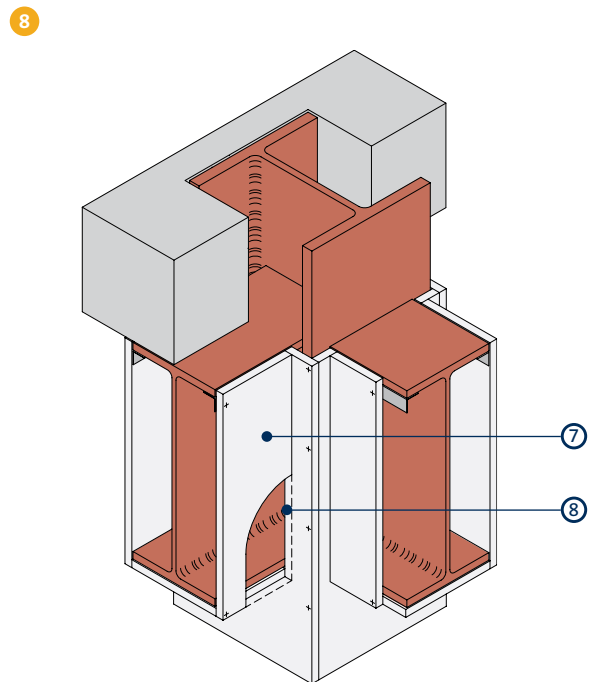
Three-sided beam encasement incorporating steel angles for up to 120 minutes fire protection



Three-sided beam encasement incorporating Glasroc F FIRECASE soldiers for up to 90 minutes fire protection



Three-sided beam encasement incorporating steel angles for up to 120 minutes fire protection - double layer



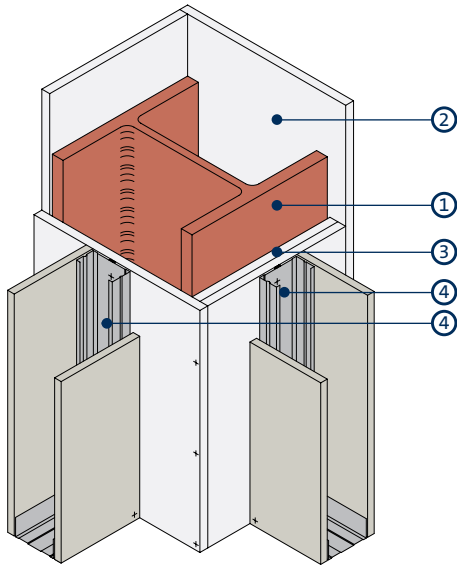
Column and beam encasement junction

- 1 Structural steel
- 2 Glasroc F FIRECASE fixed together with Glasroc F FIRECASE Screws at 150mm centres
- 3 Board joints staggered by minimum 600mm between adjacent sides
- 4 Gypframe FEA1 Steel Angle suitably fixed to beam flange at 600mm centres

- 5 60mm wide Glasroc F FIRECASE backing strip
- 6 Glasroc F FIRECASE soldiers at 1200mm centres (two together at board joints)
- 7 Beam encasement boards butted tight to column encasement
- 8 Column encasement boards cut around penetrations

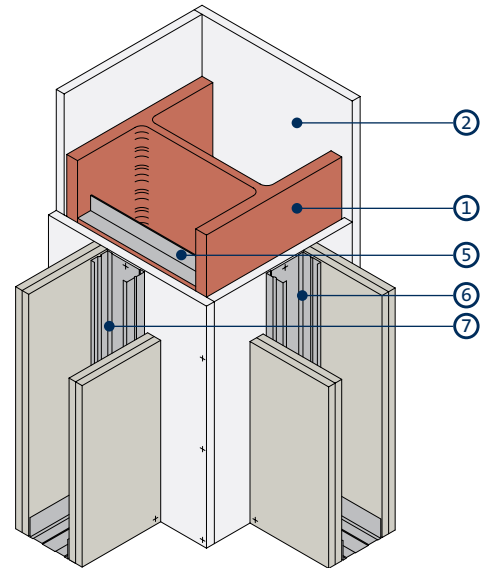
## FireCase construction details (continued)

9



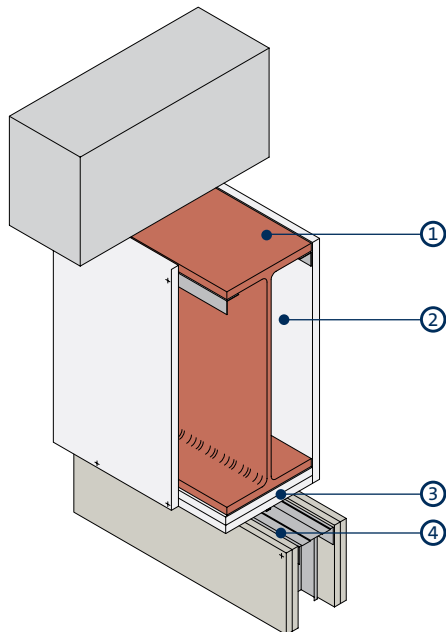
Column encasement and partition junction for partitions up to 60 minutes fire resistance and BS 5234 Light and Medium Duty

10



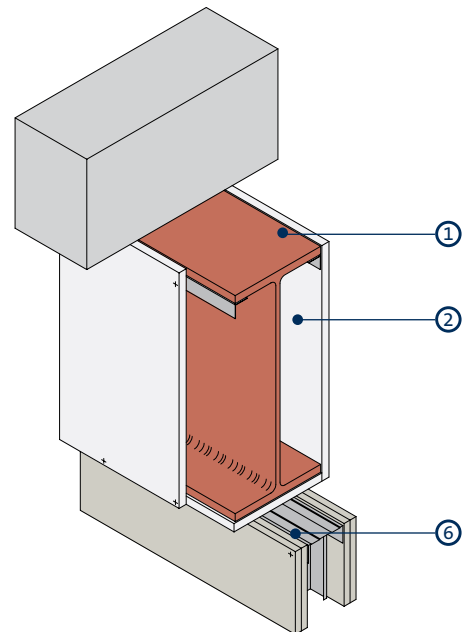
Column encasement and partition junction for partitions up to 120 minutes fire resistance and BS 5234 Heavy and Severe Duty

11



Beam encasement and partition junction for partitions up to 60 minutes fire resistance and BS 5234 Light and Medium Duty

12



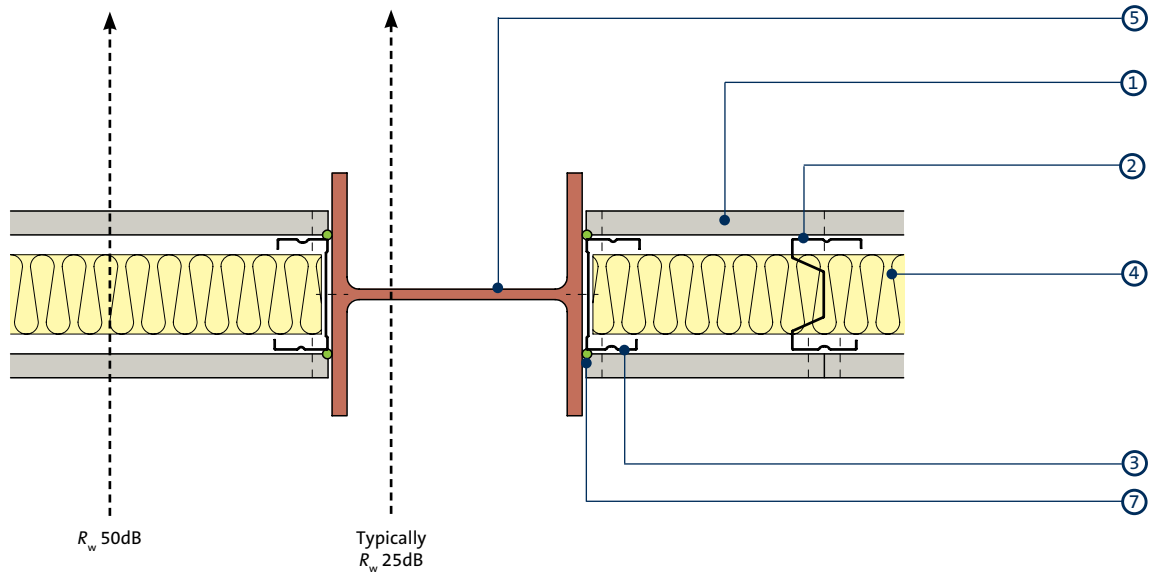
Beam encasement and partition junction for partitions up to 120 minutes fire resistance and BS 5234 Heavy and Severe Duty

- 1 Structural steel
- 2 FireCase encasement
- 3 Additional layer of Glasroc F FIRECASE forming packer to receive partition fixing
- 4 Gypframe 'C' Stud / Channel bonded to Glasroc F FIRECASE with continuous bead of Gyproc Sealant (two beads for studs wider than 75mm) and fixed with Gyproc Drywall Screws at 600mm centres (in two lines staggered by 300mm for studs wider than 75mm). Allow 24 hours before boarding

- 5 Suitable size Z-section (by others) fixed between column flanges at 600mm centres
- 6 Gypframe 'C' Stud / Channel suitably fixed through Glasroc F FIRECASE to structural steel at 600mm centres (in two lines staggered by 300mm for studs wider than 75mm)
- 7 Gypframe 'C' Stud suitably fixed through Glasroc F FIRECASE to Z-sections (in two lines for studs wider than 75mm)

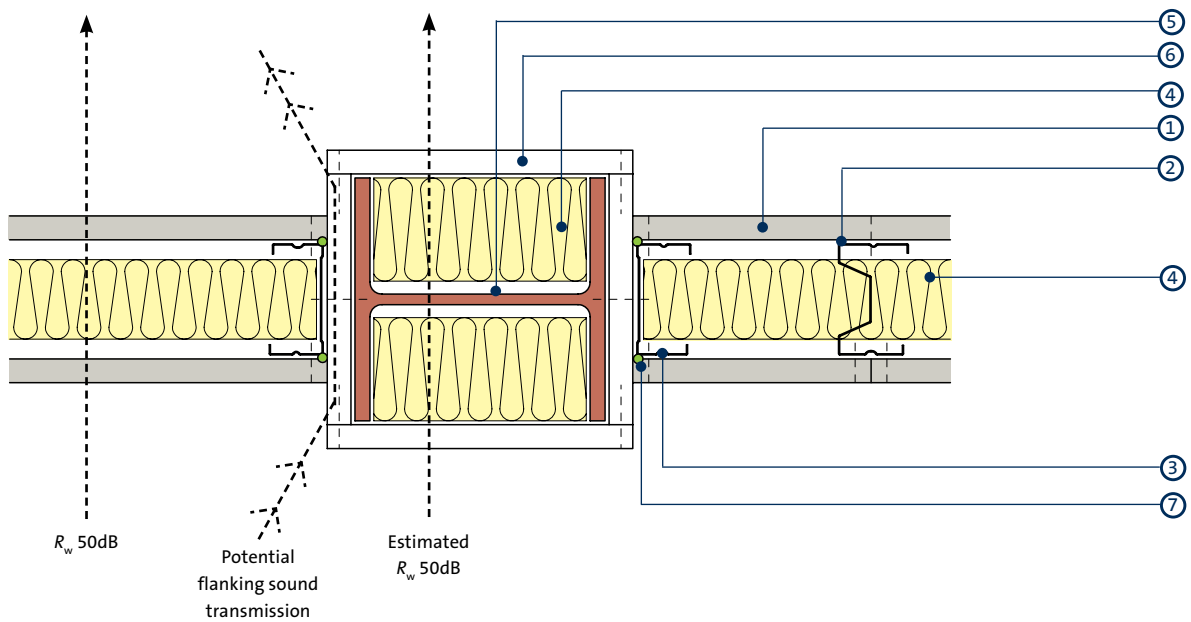
**NB** To optimise acoustic performance install Isover insulation within the encasement void.

13



Exposed / painted steel column  
No fire protection to steel, Acoustic baseline only

14



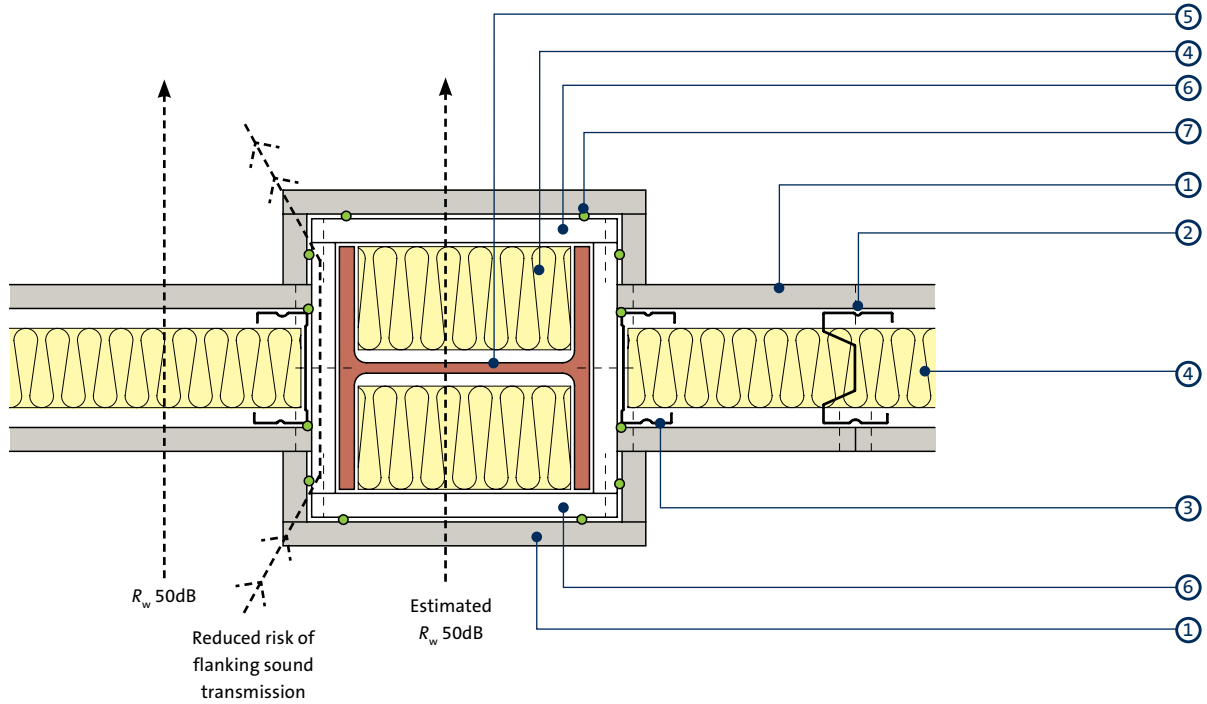
Encased steel column

- 1 Gyproc DuraLine
- 2 Gypframe AcouStud
- 3 Gypframe 'C' Stud
- 4 Isover insulation

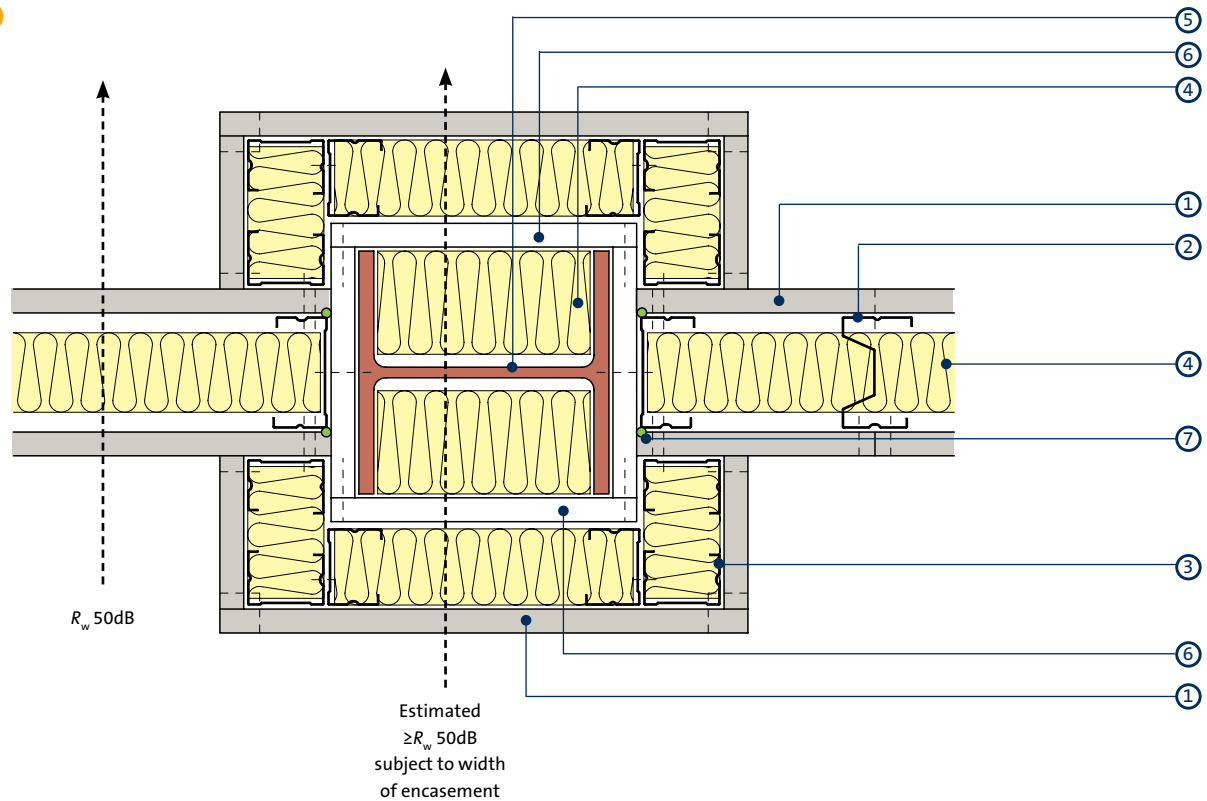
- 5 Structural steel
- 6 Glasroc F FIRECASE
- 7 Gyproc Sealant

## FireCase construction details (continued)

15



16



- 1 Gyproc DuraLine
- 2 Gypframe AcouStud
- 3 Gypframe 'C' Stud
- 4 Isover insulation

- 5 Structural steel
- 6 Glasroc F FIRECASE
- 7 Gyproc Sealant

*This page left intentionally blank*

# FireCase system components

## Gypframe metal components



### Gypframe FEA1 Steel Angle

Steel angle providing framing stability and board support.

## Board products



### Glasroc F FIRECASE

Non-combustible glass-reinforced gypsum board giving up to 120 minutes fire protection.

## Fixing products



### Glasroc F FIRECASE Screws

Corrosion resistant self-tapping steel screws with unique head design that countersinks itself into Glasroc F FIRECASE board to board and board to metal framing.

## Plasterboard accessories



### Gyproc Jointing Materials

Jointing compounds, ready mixes and adhesives for reinforcement and finishing of board joints.



### Gyproc Sealant

Used to seal paths for optimal sound insulation.

## Finishing products



### Gyproc Skimcoat

To provide a plaster skim finish on most common backgrounds including undercoat plasters and plasterboard.



### Gyproc Carlite Finish

To provide a plaster skim finish on most common backgrounds including undercoat plasters and plasterboard.



### Gyproc Carlite Ultra Finish

Offers all the benefits of Gyproc Skimcoat and Gyproc Carlite Finish with a reduced set time of 90-120mins, making it ideal for smaller jobs.



### Gyproc Drywall Primer

Used to prepare for painting.  
Tub contents 10 litre.



### Plaster accessories

Designed for the reinforcement and finishing of board joints before plaster skimming.

# FireCase installation overview

This is intended to be a basic description of how the system is built.



For four-sided protection to steel columns, Glasroc F FIRECASE boards are positioned and fixed board to board using Glasroc F FIRECASE Screws.



For two or three-sided protection to steel beams or columns, Gypframe FEA1 Steel Angles are located to both sides of the wall / soffit flange and secured using appropriate fixings.



Glasroc F FIRECASE boards are cut to width and fixed to the Gypframe FEA1 Steel Angles with Glasroc F FIRECASE Screws.



Where Glasroc F FIRECASE boards abut they can be fixed together with either Glasroc F FIRECASE Screws.



Additional layers of Glasroc F FIRECASE are fixed as before, with staggered joints. For single layer steel beam encasements, additional strips of Glasroc F FIRECASE are installed behind the ends of the fascia board-ends so as to seal the joints.



## Additional information

For full installation details, refer to the **Gyproc Installation Guide**, available to download from [gyproc.ie](http://gyproc.ie)

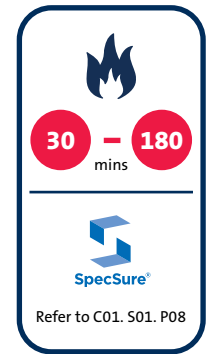
# Gyplyner ENCASE

Metal framed structural steel encasement system



## GyLyner ENCASE

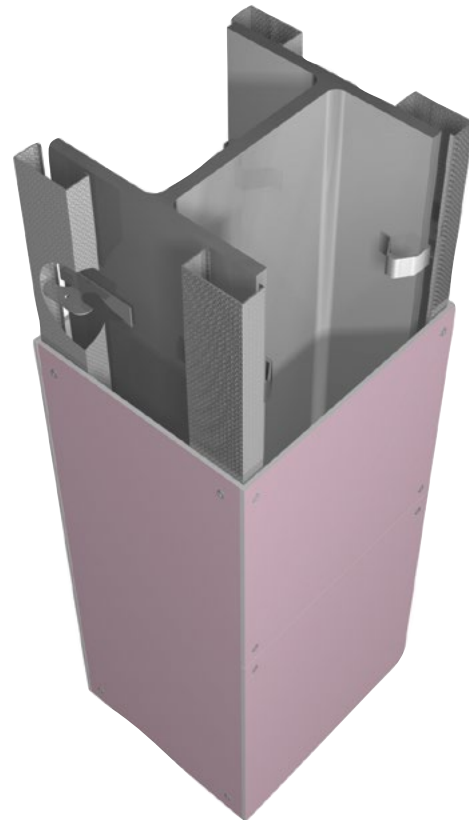
**GyLyner ENCASE** is a metal framed structural steel encasement system capable of providing up to 180 minutes fire protection to structural steel columns and beams. Installation is quick and easy due to the use of simple clip fixings to secure the framing sections.



The system will protect all universal column and beam sections with flange thicknesses between 6mm and 28mm. **GyLyner ENCASE** will also protect many joist sections. It can be used in any type of building where encasement to structural steel is required.

### Key benefits

- Reduced installation time due to the simple, clip-on framing system with **GyLyner ENCASE**
- Misalignment of structural steelwork can be accommodated by the versatile framing system to ensure the lining is straight and true
- Improved acoustic performance as a result of the boards being fixed into a framework rather than directly into the steel beam or column
- Damage to **GyLyner ENCASE** is more easily identifiable when compared to other fire protection systems such as intumescent paint



### You may also be interested in...



Need to minimise the space taken by the structural steel encasement system? If so, consider the frameless FireCase system.

► Refer to C03, S02, P71 – **FireCase**

If you need to protect structural steel within the cavity.

► Refer to C04, S07, P219 – **GypWall QUIET** or  
C04, S08, P231 – **GypWall QUIET IWL**

## Planning - key factors

Gyplyner ENCASE steel encasement is suitable for protecting structural steel sections with a section factor  $A/V$  ( $H_p/A$ ) up to  $260m^{-1}$ , calculated on the basis of box protection to three or four sides as required. It will protect all universal column and beam sections described in *BS 4: Part 1*, and many joist sections.

## Building Design

This system comprises Gypframe GL10 Gyplyner Steel Framing Clips located on steel sections at 800mm centres to support Gypframe GL1 Lining Channels.

## Lining selection

Follow either of the procedures below to determine the thickness of cladding required:

### Option 1

Use tables 2 - 4 to select steel size and fire protection then read off the required board size.

### Option 2

- 1 Ascertain whether protection is required on three or four sides of the section
- 2 Find out what period of fire resistance is required
- 3 Refer to the  $A/V$  ( $H_p/A$ ) tables 5 - 7. Locate the steel section to be protected, listed by its size and mass per metre, and read off the section factor  $A/V$
- 4 Refer to tables 8 - 11. Locate the  $A/V$  value on the vertical scale on the appropriate table. Read across the chart to the column relating to the period of fire resistance required and read off the designated thickness of the relevant cladding required to form the encasement
- 5 Select the type of board to be used

For castellated sections and cellular beams please refer to the Association for Specialist Fire Protection publication, ASFP Yellow Book - 'Fire Protection for Structural Steel in Buildings' for guidance, available to download from [asfp.org.uk](http://asfp.org.uk)

## Size of encasement

The minimum dimension of encasement required for three or four-sided protection can be determined as shown in table 1.

**Table 1 – The minimum dimension of encasements required for three or four sided protection**

Depth	Calculation
Three-sided encasements	Overall steel section depth + 25mm + the thickness of lining board
Four-sided encasements	Overall steel section depth + 50mm + twice the thickness of lining board
Width	Calculation
Three and four-sided encasements	Overall steel section width + 20mm + twice the thickness of lining board



## Handy hint

Where larger encasement systems are required, a 'boxing out' method using Gypframe studs and channels can be used.

- ▶ Refer to construction details 7 - 8.

## Partition fixing

Partitions and wall linings can be fixed through to the metal framework.

- ▶ Refer to construction details 5 - 6.

## Water vapour resistance

Vapour control can be provided to encasements which form part of an external wall lining by using Gyproc FireLine DUPLEX as the lining. Where Glasroc F FIRECASE or Glasroc F MULTIBOARD forms the lining, vapour control can be achieved by using a suitable proprietary paint treatment.

## Board finishing

- ▶ Refer to C08. S01. P483 – Finishes, Plaster Skimming.



## Important information

- Where the steel section web or flange dimension exceeds 600mm, additional support will be required for the cladding. Noggings of Gypframe GL1 Lining Channel are installed at 600mm centres between adjacent Gypframe GL1 Lining Channels to form supplementary framing.
- All board joints should be staggered by a minimum of 600mm.

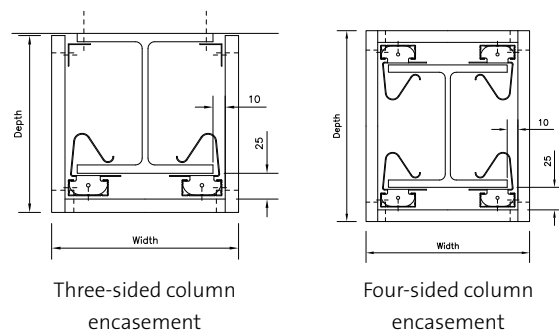




Table 2 – 550°C chart to BS 476: Part 20 for selecting the required Gyproc FireLine lining thickness for universal beam sizes

Universal beams serial size of steel (mm x mm x kg/m)			Total Gyproc FireLine board thickness (mm) to achieve fire resistance below <sup>1</sup>							
			3 sided encasements				4 sided encasements			
D	B	Mass/metre	30 min	60 min	90 min	120 min	30 min	60 min	90 min	120 min
1016	305	487	12.5	12.5	15	27.5	12.5	12.5	15	27.5
	305	438	12.5	12.5	15	27.5	12.5	12.5	15	27.5
	305	393	12.5	12.5	15	27.5	12.5	12.5	15	27.5
	305	349	12.5	12.5	15	27.5	12.5	12.5	15	27.5
	305	314	12.5	12.5	15	27.5	12.5	12.5	15	27.5
	305	272	12.5	12.5	15	27.5	12.5	12.5	25	27.5
	305	249	12.5	12.5	15	27.5	12.5	12.5	25	27.5
	305	222	12.5	12.5	15	27.5	12.5	12.5	25	30
914	419	388	12.5	12.5	15	27.5	12.5	12.5	15	27.5
	419	343	12.5	12.5	15	27.5	12.5	12.5	15	27.5
	305	289	12.5	12.5	15	27.5	12.5	12.5	15	27.5
	305	253	12.5	12.5	15	27.5	12.5	12.5	25	27.5
	305	224	12.5	12.5	25	27.5	12.5	12.5	25	27.5
	305	201	12.5	12.5	25	27.5	12.5	12.5	25	30
838	292	226	12.5	12.5	15	27.5	12.5	12.5	25	27.5
	292	194	12.5	12.5	25	27.5	12.5	12.5	25	30
	292	176	12.5	12.5	25	30	12.5	12.5	25	30
762	267	197	12.5	12.5	15	27.5	12.5	12.5	25	27.5
	267	173	12.5	12.5	25	27.5	12.5	12.5	25	30
	267	147	12.5	12.5	25	30	12.5	12.5	25	30
	267	134	12.5	12.5	25	30	12.5	12.5	25	30
686	254	170	12.5	12.5	25	27.5	12.5	12.5	25	30
	254	152	12.5	12.5	25	27.5	12.5	12.5	25	30
	254	140	12.5	12.5	25	30	12.5	12.5	25	30
	224	125	30	12.5	12.5	25	30	12.5	12.5	25
610	305	238	12.5	12.5	15	27.5	12.5	12.5	15	27.5
	305	179	12.5	12.5	15	27.5	12.5	12.5	25	27.5
	305	149	12.5	12.5	25	27.5	12.5	12.5	25	30
	229	140	12.5	12.5	25	27.5	12.5	12.5	25	30
	229	125	12.5	12.5	25	30	12.5	12.5	25	30
	229	113	12.5	12.5	25	30	12.5	12.5	25	30
	229	101	12.5	12.5	25	30	12.5	12.5	25	30
	178	100	12.5	12.5	25	30	12.5	12.5	25	30
	178	92	12.5	12.5	25	30	12.5	12.5	25	30
	178	82	12.5	12.5	25	30	12.5	12.5	25	30
	533	312	273	12.5	12.5	15	27.5	12.5	12.5	15
312		219	12.5	12.5	15	27.5	12.5	12.5	15	27.5
312		182	12.5	12.5	15	27.5	12.5	12.5	25	27.5
312		151	12.5	12.5	25	27.5	12.5	12.5	25	30
210		138	12.5	12.5	25	27.5	12.5	12.5	25	27.5
210		122	12.5	12.5	25	27.5	12.5	12.5	25	30
210		109	12.5	12.5	25	30	12.5	12.5	25	30
210		101	12.5	12.5	25	30	12.5	12.5	25	30
210		92	12.5	12.5	25	30	12.5	12.5	25	30
210		82	12.5	12.5	25	30	12.5	12.5	25	30
165		85	12.5	12.5	25	30	12.5	12.5	25	30
165		75	12.5	12.5	25	30	12.5	12.5	25	30
165		66	12.5	12.5	25	30	12.5	12.5	25	30

<sup>1</sup> Gyproc FireLine thickness combinations

- 12.5mm = 1 x 12.5mm
- 25mm = 2 x 12.5mm
- 30mm = 2 x 15mm
- 37.5mm = 3 x 12.5mm

System reference: D150001

Beam/column/joist dimension orientation:

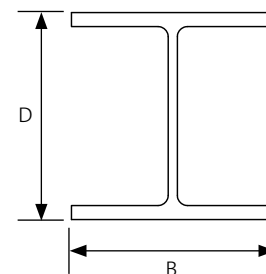




Table 2 (continued) – 550°C chart to BS 476: Part 20 for selecting the required Gyproc FireLine lining thickness for universal beam sizes

▶ Refer to C02. S01. P18

Universal beams serial size of steel (mm x mm x kg/m)			Total Gyproc FireLine board thickness (mm) to achieve fire resistance below <sup>1</sup>								
			3 sided encasements				4 sided encasements				
D	B	Mass/metre	30 min	60 min	90 min	120 min	30 min	60 min	90 min	120 min	
457	191	161	12.5	12.5	15	27.5	12.5	12.5	15	27.5	
	191	133	12.5	12.5	15	27.5	12.5	12.5	25	27.5	
	191	106	12.5	12.5	25	27.5	12.5	12.5	25	30	
	191	98	12.5	12.5	25	30	12.5	12.5	25	30	
	191	89	12.5	12.5	25	30	12.5	12.5	25	37.5	
	191	82	12.5	12.5	25	30	12.5	12.5	25	37.5	
	191	74	12.5	12.5	25	37.5	12.5	12.5	25	37.5	
	191	67	12.5	12.5	25	37.5	12.5	12.5	25	37.5	
	152	82	12.5	12.5	25	30	12.5	12.5	25	37.5	
	152	74	12.5	12.5	25	37.5	12.5	12.5	25	37.5	
	152	67	12.5	12.5	25	37.5	12.5	12.5	25	37.5	
	152	60	12.5	12.5	25	37.5	12.5	12.5	25	37.5	
	152	52	12.5	12.5	25	37.5	12.5	15	25	37.5	
	406	178	85	12.5	12.5	25	30	12.5	12.5	25	30
		178	74	12.5	12.5	25	30	12.5	12.5	25	37.5
178		67	12.5	12.5	25	37.5	12.5	12.5	25	37.5	
178		60	12.5	12.5	25	37.5	12.5	12.5	25	37.5	
178		54	12.5	12.5	25	37.5	12.5	15	25	37.5	
140		53	12.5	12.5	25	37.5	12.5	12.5	25	37.5	
140		46	12.5	12.5	25	37.5	12.5	15	25	37.5	
140		39	12.5	15	25	37.5	12.5	25	27.5	40	
356		171	67	12.5	12.5	25	30	12.5	12.5	25	37.5
	171	57	12.5	12.5	25	37.5	12.5	12.5	25	37.5	
	171	51	12.5	12.5	25	37.5	12.5	12.5	25	37.5	
	171	45	12.5	12.5	25	37.5	12.5	15	25	37.5	
	127	39	12.5	12.5	25	37.5	12.5	15	25	40	
	127	33	12.5	15	25	40	12.5	25	27.5	40	
305	165	54	12.5	12.5	25	37.5	12.5	12.5	25	37.5	
	165	46	12.5	12.5	25	37.5	12.5	12.5	25	37.5	
	165	40	12.5	12.5	25	37.5	12.5	15	25	37.5	
	127	48	12.5	12.5	25	37.5	12.5	12.5	25	37.5	
	127	42	12.5	12.5	25	37.5	12.5	12.5	25	37.5	
	127	37	12.5	12.5	25	37.5	12.5	15	25	37.5	
	102	33	12.5	15	25	37.5	12.5	25	25	40	
	102	28	12.5	25	25	40	12.5	25	27.5	42.5	
	102	25	12.5	25	27.5	40	12.5	25	27.5	42.5	
	254	146	43	12.5	12.5	25	37.5	12.5	12.5	25	37.5
146		37	12.5	12.5	25	37.5	12.5	15	25	37.5	
146		31	12.5	12.5	25	37.5	12.5	25	25	40	
102		28	12.5	15	25	37.5	12.5	25	25	40	
102		25	12.5	15	25	37.5	12.5	25	27.5	40	
102		22	12.5	25	27.5	40	12.5	25	27.5	42.5	
203	133	30	12.5	12.5	25	37.5	12.5	15	25	37.5	
	133	25	12.5	15	25	37.5	12.5	25	27.5	40	
	102	23	12.5	15	25	37.5	12.5	25	27.5	40	
178	102	19	12.5	15	25	37.5	12.5	25	27.5	42.5	
152	89	16	12.5	15	25	40	12.5	25	27.5	42.5	
127	76	13	12.5	25	25	40	12.5	25	27.5	42.5	

<sup>1</sup> Gyproc FireLine thickness combinations

- 12.5mm = 1 x 12.5mm
- 15mm = 1 x 15mm
- 25mm = 2 x 12.5mm
- 27.5mm = 1 x 15mm + 1 x 12.5mm
- 30mm = 2 x 15mm
- 37.5mm = 3 x 12.5mm
- 40mm = 1 x 15mm + 2 x 12.5mm
- 42.5mm = 2 x 15mm + 1 x 12.5mm

System reference: D150001

Beam/column/joist dimension orientation:

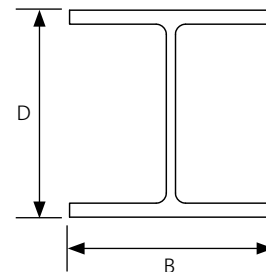




Table 3 – 550°C chart to BS 476: Part 20 for selecting the required Gyproc FireLine lining thickness for universal column sizes

Universal columns serial size of steel (mm x mm x kg/m)			Total Gyproc FireLine board thickness (mm) to achieve fire resistance below <sup>1</sup>							
			3 sided encasements				4 sided encasements			
D	B	Mass/metre	30 min	60 min	90 min	120 min	30 min	60 min	90 min	120 min
356	406	634	12.5	12.5	15	27.5	12.5	12.5	15	27.5
	406	551	12.5	12.5	15	27.5	12.5	12.5	15	27.5
	406	467	12.5	12.5	15	27.5	12.5	12.5	15	27.5
	406	393	12.5	12.5	15	27.5	12.5	12.5	15	27.5
	406	340	12.5	12.5	15	27.5	12.5	12.5	15	27.5
	406	287	12.5	12.5	15	27.5	12.5	12.5	15	27.5
	406	235	12.5	12.5	15	27.5	12.5	12.5	15	27.5
	368	202	12.5	12.5	15	27.5	12.5	12.5	15	27.5
	368	177	12.5	12.5	15	27.5	12.5	12.5	15	27.5
	368	153	12.5	12.5	15	27.5	12.5	12.5	25	27.5
	368	129	12.5	12.5	15	27.5	12.5	12.5	25	30
	305	305	283	12.5	12.5	15	27.5	12.5	12.5	15
305		240	12.5	12.5	15	27.5	12.5	12.5	15	27.5
305		198	12.5	12.5	15	27.5	12.5	12.5	15	27.5
305		158	12.5	12.5	15	27.5	12.5	12.5	15	27.5
305		137	12.5	12.5	15	27.5	12.5	12.5	15	27.5
305		118	12.5	12.5	15	27.5	12.5	12.5	25	27.5
305		97	12.5	12.5	25	27.5	12.5	12.5	25	30
254	254	167	12.5	12.5	15	27.5	12.5	12.5	15	27.5
	254	132	12.5	12.5	15	27.5	12.5	12.5	15	27.5
	254	107	12.5	12.5	15	27.5	12.5	12.5	25	27.5
	254	89	12.5	12.5	15	27.5	12.5	12.5	25	30
	254	73	12.5	12.5	25	27.5	12.5	12.5	25	30
203	203	127	12.5	12.5	15	27.5	12.5	12.5	15	27.5
	203	113	12.5	12.5	15	27.5	12.5	12.5	15	27.5
	203	100	12.5	12.5	15	27.5	12.5	12.5	15	27.5
	203	86	12.5	12.5	15	27.5	12.5	12.5	25	27.5
	203	71	12.5	12.5	15	27.5	12.5	12.5	25	30
	203	60	12.5	12.5	25	27.5	12.5	12.5	25	30
	203	52	12.5	12.5	25	30	12.5	12.5	25	30
	203	46	12.5	12.5	25	30	12.5	12.5	25	30
152	152	51	12.5	12.5	25	27.5	12.5	12.5	25	30
	152	44	12.5	12.5	25	27.5	12.5	12.5	25	30
	152	37	12.5	12.5	25	30	12.5	12.5	25	30
	152	30	12.5	12.5	25	30	12.5	12.5	25	30
	152	23	12.5	12.5	25	30	12.5	25	27.5	30



Table 4 – 550°C chart to BS 476: Part 20 for selecting the required Gyproc FireLine lining thickness for universal joist sizes

Universal joist serial size of steel (mm x mm x kg/m)			Total Gyproc FireLine board thickness (mm) to achieve fire resistance below <sup>1</sup>							
			3 sided encasements				4 sided encasements			
D	B	Mass/metre	30 min	60 min	90 min	120 min	30 min	60 min	90 min	120 min
254	203	82	12.5	12.5	15	27.5	12.5	12.5	25	30
	114	37	12.5	12.5	25	30	12.5	12.5	25	30
203	152	52	12.5	12.5	25	27.5	12.5	12.5	25	30
	102	25	12.5	12.5	25	30	12.5	15	25	30
178	102	22	12.5	12.5	25	30	12.5	25	27.5	30
152	127	37	12.5	12.5	25	30	12.5	12.5	25	30
	89	17	12.5	15	25	30	12.5	25	27.5	30
	76	18	12.5	12.5	25	30	12.5	25	25	30
127	114	30	12.5	12.5	25	30	12.5	12.5	25	30
	114	27	12.5	12.5	25	30	12.5	12.5	25	30
	76	16	12.5	12.5	25	30	12.5	15	25	30
	76	13	12.5	15	25	30	12.5	25	27.5	30
114	114	27	12.5	12.5	25	30	12.5	12.5	25	30
102	102	23	12.5	12.5	25	30	12.5	12.5	25	30
	64	10	12.5	15	27.5	30				
	44	7	12.5	25	27.5	30				
89	89	19	12.5	12.5	25	30	12.5	12.5	25	30
76	76	15	12.5	12.5	25	30	12.5	12.5	25	30
	76	13	12.5	12.5	25	30	12.5	15	25	30

<sup>1</sup> Gyproc FireLine thickness combinations

12.5mm = 1 x 12.5mm

15mm = 1 x 15mm

25mm = 2 x 12.5mm

27.5mm = 1 x 15mm + 1 x 12.5mm

30mm = 2 x 15mm

37.5mm = 3 x 12.5mm

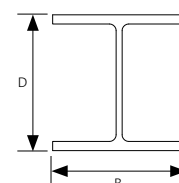
40mm = 1 x 15mm + 2 x 12.5mm

42.5mm = 2 x 15mm + 1 x 12.5mm

- protection not possible

System reference: D150001

Beam/column/joist dimension orientation:



# Gyplyner ENCASE design (continued)

Table 5 – Section factor A/V (Hp/A) of universal beams

Universal beams serial size of steel (mm x mm x kg/m)			A / V values		
			3 sided encasements	4 sided encasements	
D	B	Mass/metre	m <sup>-1</sup>	m <sup>-1</sup>	
1016	305	487	40	45	
	305	438	40	50	
	305	393	45	55	
	305	349	50	60	
	305	314	55	65	
	305	272	65	75	
	305	249	70	80	
	305	222	80	90	
	914	419	388	45	55
		419	343	50	60
305		289	60	65	
305		253	65	75	
305		224	75	85	
305		201	80	95	
838	292	226	70	80	
	292	194	80	90	
	292	176	90	100	
762	267	197	70	85	
	267	173	80	95	
	267	147	95	110	
	267	134	105	120	
686	254	170	75	90	
	254	152	85	95	
	254	140	90	105	
	254	125	100	115	
610	305	238	50	60	
	305	179	70	80	
	305	149	80	95	
	229	140	80	95	
	229	125	90	105	
	229	113	100	115	
	229	101	110	130	
	178	100	110	125	
	178	92	120	135	
	178	82	130	150	
	533	312	273	40	50
		312	219	50	65
		312	182	60	75
312		151	75	90	
210		138	75	85	
210		122	85	95	
210		109	95	110	
210		101	100	115	
210		92	110	125	
210		82	120	140	
165		85	115	130	
165		75	130	145	
165		66	145	165	

Table 5 (continued) – Section factor A/V (Hp/A) of universal beams

Universal beams serial size of steel (mm x mm x kg/m)			A / V values		
			3 sided encasements	4 sided encasements	
D	B	Mass/metre	m <sup>-1</sup>	m <sup>-1</sup>	
457	191	161	60	65	
	191	133	70	80	
	191	106	85	100	
	191	98	90	105	
	191	89	100	115	
	191	82	105	125	
	191	74	115	135	
	191	67	130	150	
	152	82	105	120	
	152	74	115	130	
	152	67	125	145	
	152	60	140	160	
	152	52	160	180	
	406	178	85	95	110
178		74	105	125	
178		67	115	140	
178		60	130	155	
178		54	145	170	
140		53	140	160	
140		46	160	185	
140		39	190	215	
356		171	67	105	125
		171	57	120	145
		171	51	135	160
	171	45	150	180	
	127	39	165	195	
	127	33	195	225	
	305	165	54	115	140
		165	46	135	160
165		40	150	185	
127		48	120	145	
127		42	140	160	
127		37	155	180	
102		33	175	200	
102		28	200	230	
102		25	225	255	
254		146	43	120	150
	146	37	140	170	
	146	31	165	200	
	102	28	175	200	
	102	25	190	225	
	102	22	220	255	
	203	133	30	145	180
		133	25	170	210
102		23	175	205	
178		102	19	190	230
152	89	16	195	235	
127	76	13	200	245	

Beam/column/joist dimension orientation:

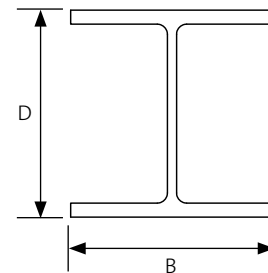


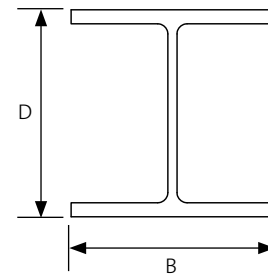
Table 6 – Section factor A/V (Hp/A) of universal columns

Universal columns serial size of steel (mm x mm x kg/m)			A / V values	
			3 sided encasements	4 sided encasements
D	B	Mass/metre	m <sup>-1</sup>	m <sup>-1</sup>
356	406	634	15	20
	406	551	20	25
	406	467	20	30
	406	393	25	35
	406	340	30	35
	406	287	30	45
	406	235	40	50
	368	202	45	60
	368	177	50	65
	368	153	55	75
	368	129	65	90
	305	305	283	30
305		240	35	45
305		198	40	50
305		158	50	65
305		137	55	70
305		118	60	85
305		97	75	100
254		254	167	40
	254	132	50	65
	254	107	60	75
	254	89	70	90
	254	73	80	110
	203	203	127	45
203		113	45	60
203		100	55	70
203		86	60	80
203		71	70	95
203		60	80	110
203		52	95	125
203		46	105	140
152		152	51	75
	152	44	85	115
	152	37	100	135
	152	30	120	160
	152	23	155	210

Table 7 – Section factor A/V (Hp/A) of universal joist

Universal joist serial size of steel (mm x mm x kg/m)			A / V values	
			3 sided encasements	4 sided encasements
D	B	Mass/metre	m <sup>-1</sup>	m <sup>-1</sup>
254	203	82	70	90
	114	37	130	155
203	152	52	85	105
	102	25	155	190
178	102	22	165	205
152	127	37	90	120
	89	17	180	220
127	76	18	165	200
	114	30	100	130
114	114	27	110	140
	76	16	155	195
102	76	13	195	240
	114	27	100	135
89	102	23	105	140
	64	10	215	270
76	44	7	260	305
	89	19	105	145
76	76	15	120	165
	76	13	140	185

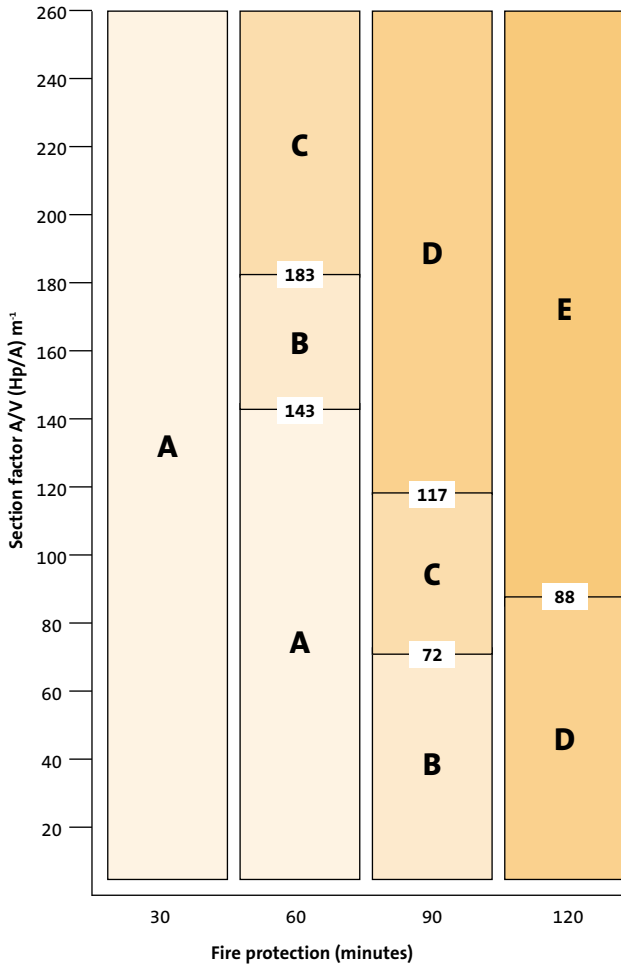
Beam/column/joist dimension orientation:



# Gyplyner ENCASE performance - columns and beams



**Table 8**  
The 550°C chart to BS 476: Part 20 for selecting Gyproc FireLine lining thickness  
▶ Refer to C02. S01. P18



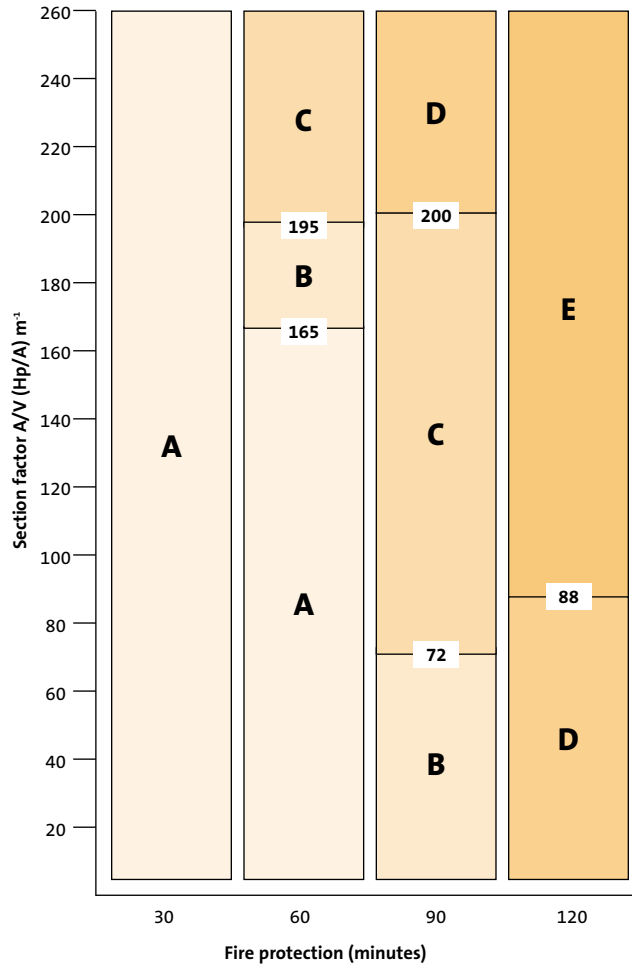
**Key - Thickness of Gyproc FireLine required**

- A = 12.5mm
- B = 15mm
- C = 25mm (12.5mm + 12.5mm)
- D = 30mm (15mm + 15mm)
- E = 45mm (15mm + 15mm + 15mm)

System reference: D150001



**Table 9**  
The 550°C chart to BS 476: Part 20 for selecting Gyproc FireLine lining thickness  
▶ Refer to C02. S01. P18



**Key - Thickness of Gyproc FireLine required**

- A = 12.5mm
- B = 15mm
- C = 25mm (12.5mm + 12.5mm)
- D = 27.5mm (15mm + 12.5mm)
- E = 30mm (15mm + 15mm)

System reference: D150001

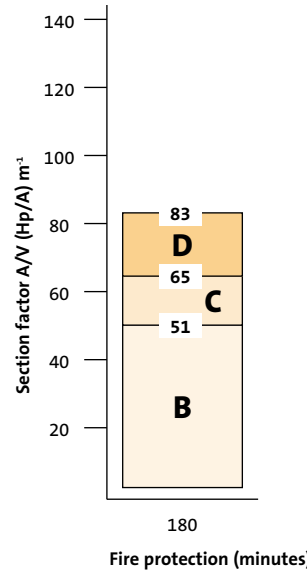
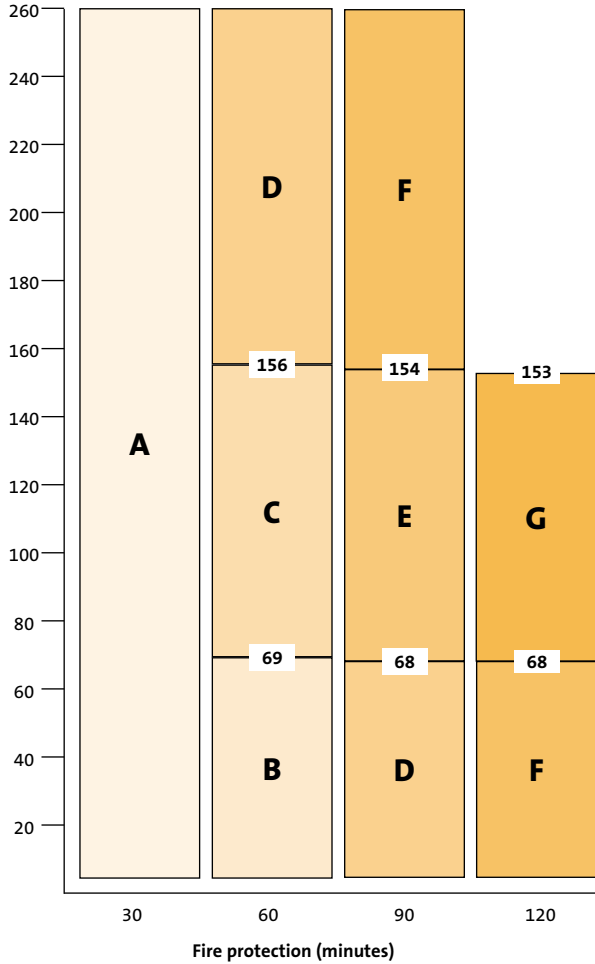
**NB** The fire resistance performances are for imperforate linings with all joints taped and filled or skimmed. The quoted performances are achieved only if Gyproc and Saint-Gobain Isover components are used throughout, and the Company's fixing recommendations are strictly observed. Any variation in the specifications should be checked with Gyproc.



**Table 10**  
Solutions to satisfy the 550°C criteria when tested in accordance with BS 476: Part 20: 1987 (beam and column encasement)  
▶ Refer to C02. S01. P18



**Table 11**  
Solutions to satisfy the 550°C criteria when tested in accordance with BS 476: Part 21: 1987 (column encasement) lining thickness  
▶ Refer to C02. S01. P18



**Key - Thickness of Gyproc F MULTIBOARD required**

- A = 6mm
- B = 10mm
- C = 12.5mm
- D = 20mm (10mm + 10mm)
- E = 25mm (12.5mm + 12.5mm)
- F = 30mm (10mm + 10mm + 10mm)
- G = 37.5mm (12.5mm + 12.5mm + 12.5mm)

System reference: D150002

**Key - Thickness of Glasroc F FIRECASE required**

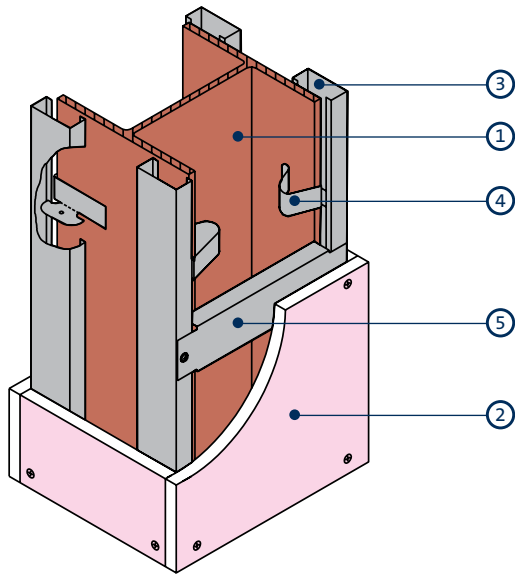
- B = 40mm (20mm + 20mm)
- C = 45mm (25mm + 20mm)
- D = 50mm (25mm + 25mm)

System reference: D120003

**(NB)** The fire resistance performances are for imperforate linings with all joints taped and filled or skimmed. The quoted performances are achieved only if Gyproc and Saint-Gobain Isover components are used throughout, and the Company's fixing recommendations are strictly observed. Any variation in the specifications should be checked with Gyproc.

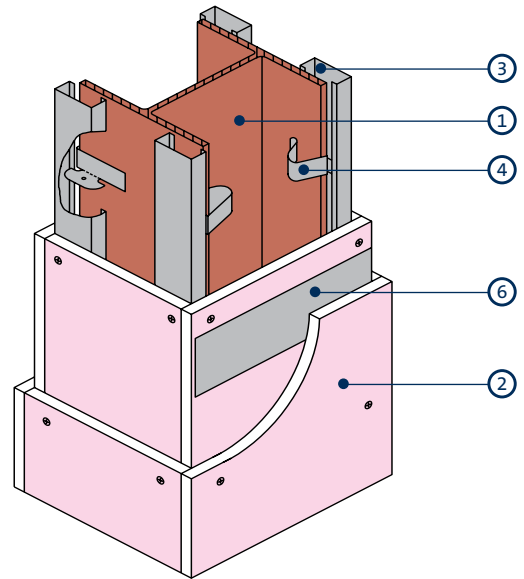
# Gyplyner ENCASE construction details

1



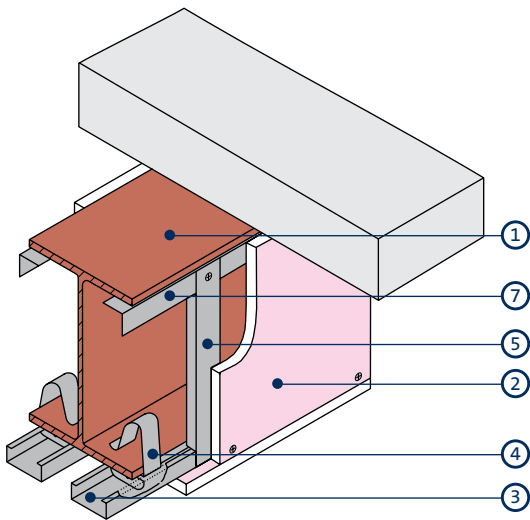
Four-sided column encasement - single layer

2



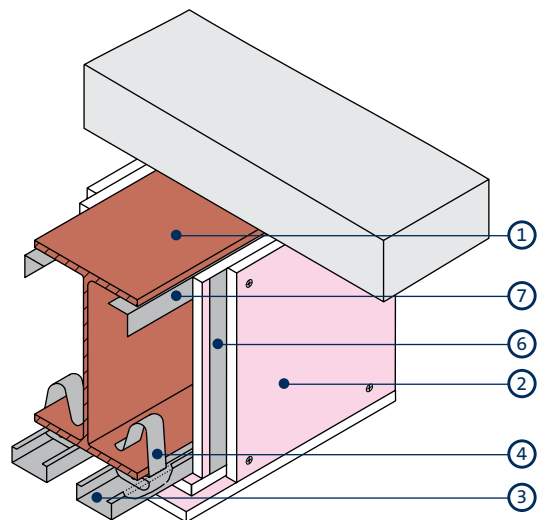
Four-sided column encasement - double layer

3



Three-sided beam encasement - single layer

4

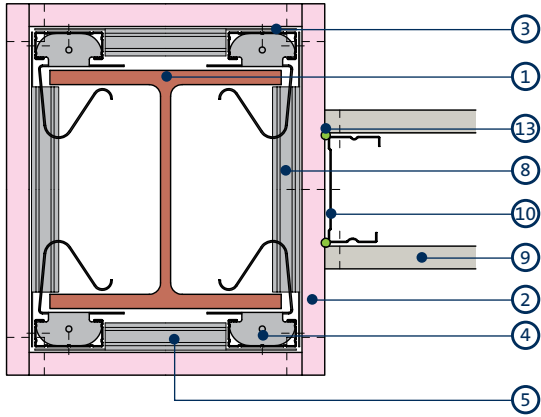


Three-sided beam encasement - double layer

- 1 Structural steel
- 2 Gyproc FireLine or Glasroc boards
- 3 Gypframe GL1 Lining Channel
- 4 Gypframe GL10 Gyplyner Steel Framing Clip

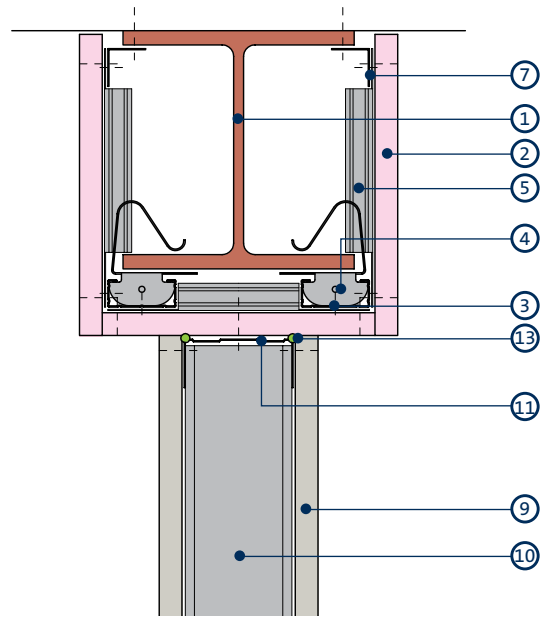
- 5 Gypframe GL1 Lining Channel nogging or Gypframe GFT1 Fixing 'T' at board joints
- 6 Gypframe GFS1 Fixing Strap at board joints
- 7 Gypframe GA2 Steel Angle

5



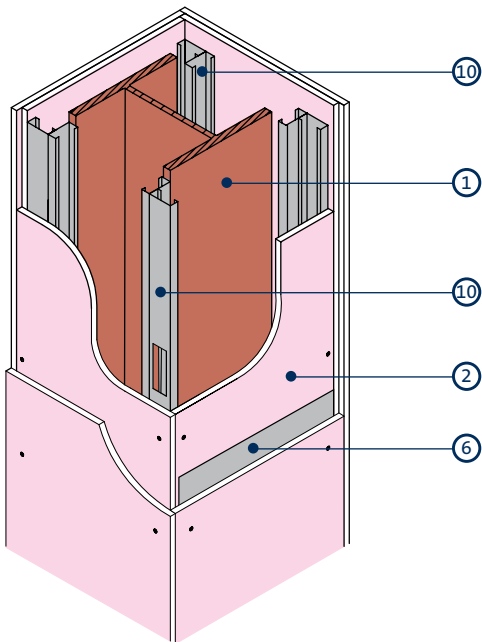
Column encasement and partition junction

6



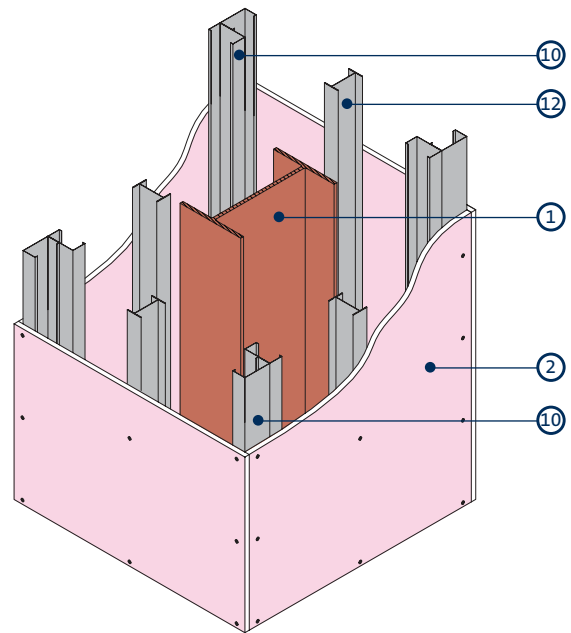
Beam encasement and partition junction

7



Boxing out for columns up to 600mm wide using Gyplyner iw.

8



Boxing out for columns over 600mm wide using Gyplyner iw.

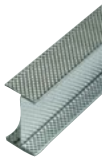
- 1 Structural steel
- 2 Gyproc FireLine or Glasroc boards
- 3 Gypframe GL1 Lining Channel
- 4 Gypframe GL10 Gyplyner Steel Framing Clip
- 5 Gypframe GL1 Lining Channel nogging or Gypframe GFT1 Fixing 'T' at board joints
- 6 Gypframe GFS1 Fixing Strap at board joints

- 7 Gypframe GA2 Steel Angle
- 8 Gypframe GL1 Lining Channel nogging at 600mm centres
- 9 Gyproc plasterboard
- 10 Gypframe 'C' Studs
- 11 Gypframe Folded Edge Standard Floor & Ceiling Channel
- 12 Gypframe 'T' Stud at 600mm centres
- 13 Gyproc Sealant

**NB** To optimise acoustic performance install Isover insulation within the encasement void.

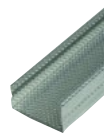
# Gyplyner ENCASE system components

## Gypframe metal components



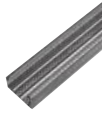
### Gypframe 'I' Studs (48 I 50, 60 I 50, 60 I 70, 70 I 50, 70 I 70, 92 I 90, 146 I 80, 146 TI 90 Tabbed)

Enhanced strength stud that allows for increased lining height, designed to receive fixing of board. Allows an increase to the overall size of encasement.



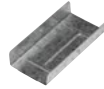
### Gypframe 'C' Studs (48 S 50, 60 S 50, 70 S 50, 70 S 60, 95 S 50, 92 S 60, 92 S 10, 146 S 50)

Vertical stud providing acoustic and structural performances designed to receive fixing of board. Allows an increase to the overall size of encasement.



### Gypframe GL1 Lining Channel

Main support channel to receive fixing of board.



### Gypframe GL3 Channel Connector

For joining two sections of Gypframe GL1 Lining Channel.



### Gypframe GL10 Gyplyner Steel Framing Clip

For connecting GL1 Lining Channel to flanges of structural steel.



### Gypframe GA2 Steel Angle

Steel angle providing framing stability and board support.



### Gypframe GFS1 Fixing Strap

Used to support horizontal board joints.



### Gypframe GFT1 Fixing 'T'

Used to support horizontal board joints.

## Board products



### Gyproc FireLine<sup>1</sup>

Gypsum plasterboard with fire resistant additives.



### Glasroc F FIRECASE

Non-combustible glass-reinforced gypsum board giving up to 180 minutes fire protection.



### Gyproc DuraLine<sup>1</sup>

Gypsum plasterboard with fire resistant additives and a high density core for enhanced sound insulation and impact resistance performance.



### Glasroc F MULTIBOARD

Non-combustible glass-reinforced gypsum board.

<sup>1</sup> Also available in a Moisture Resistant (MR) version. MR boards are specified in intermittent wet use areas.

## Fixing products



### Gyproc Drywall Screws

Corrosion resistant self-tapping steel screws for fixing board-to-timber and board-to-metal framing less than 0.8mm thick.



### Gyproc Wafer Head Drywall Screws

Corrosion resistant self-tapping steel screws for fixing metal to metal framing less than 0.8mm thick.



### Gyproc Collated Drywall Screws

Corrosion resistant self-tapping steel screws for fixing board-to-timber and board-to-metal framing less than 0.8mm thick.



### Glasroc F FIRECASE Screws

Corrosion resistant self-tapping steel screws with unique head design that countersinks itself into Glasroc F FIRECASE board to metal framing.

## Gyplyner ENCASE system components (continued)

### Plasterboard accessories



#### Gyproc Jointing Materials

Jointing compounds, ready mixes and adhesives for reinforcement and finishing of board joints.



#### Gyproc Drywall Primer

Used to prepare for painting.  
Tub contents 10 litre

### Finishing products



#### Gyproc Skimcoat

To provide a plaster skim finish on most common backgrounds including undercoat plasters and plasterboard.



#### Gyproc Carlite Finish

To provide a plaster skim finish on most common backgrounds including undercoat plasters and plasterboard.



#### Gyproc Carlite Ultra Finish

Offers all the benefits of Gyproc Skimcoat and Gyproc Carlite Finish with a reduced set time of 90-120mins, making it ideal for smaller jobs.



#### Plaster accessories

Designed for the reinforcement and finishing of board joints before plaster skimming.



### Handy hint

- If you require 180 minutes fire protection, double layer Glasroc F FIRECASE provides the ideal solution.

## Gyplyner ENCASE installation overview

This is intended to be a basic description of how the system is built.



Four-sided protection to steel columns, Gypframe GL10 Gyplyner Steel Framing Clips are friction-fitted onto the column / beam flanges at 800mm centres.



Gypframe GL1 Lining Channels are located over the clips to form the steel framework.



For two or three-sided beams or columns Gypframe GA2 Steel Angle is located to both sides of the wall / soffit flange and secured using appropriate fixings.



Boards are cut to width and fixed to all framing members using Gyproc Drywall Screws.



Board-end joints are backed using horizontal noggings formed from an appropriate Gypframe component: Gypframe GL1 Lining Channel, Gypframe GFS1 Fixing Strap or Gypframe GFT1 Fixing 'T'.



### Additional information

For full installation details, refer to the [Gyproc Installation Guide](#), available to download from [gyproc.ie](#)

# CO4

## Partitions

# Partitions

This section contains a full range of lightweight partition and wall systems for use in new and existing buildings. They cover all applications, from simple space division to high performance walls



# Partitions

Gyproc offers a full range of lightweight partition and wall systems. Our systems are non-loadbearing and constructed using modern, drylining techniques. Gyproc metal framed partitions and walls can be used in all types of new and existing buildings, including private and social housing, apartments, healthcare, educational facilities, recreational and industrial properties.

They cover all applications, from simple space division, through to high performance walls designed to meet the most demanding fire resistance, sound insulation, impact and height requirements.

Gyproc partition systems are constructed using lightweight materials, which can give rise to significant savings in structural design compared to masonry alternatives. Big benefits also include the speed of installation and reduction to overall build costs.

Buildings need to evolve throughout their life to suit changing demands placed upon them. Our lightweight partition systems are easy to reconfigure with minimal impact to both building and occupants resulting in less disruption, optimising the transformation process.



## You may also be interested in...

For unique performance situations with specialist requirements:




- Curved partitions
- Access to build from one side only
- High levels of fire resistance
- High security including bomb blast

► Refer to C05. S01. P289 – Specialist partitions

## Partitions

When specifying partitions, a number of performance characteristics are normally used to determine the required solution. Depending on the project or construction type, these performance parameters could be set by minimum regulatory standards, or a client or customer requirement for buildings that offer the highest standards of performance and comfort.

Our quick-reference partition system guide, below, allows you to simply select the performance categories of interest and identify the Gyproc partitions systems that best satisfy your project requirements.

					1	
30 - 120	75 - 211	34 - 63	47 - 57	Medium - Severe	8100	GypWall
60 - 120	102 - 132	42 - 58	-	Severe	4900	GypWall <b>ROBUST</b>
30 - 60	97 - 203	44 - 62	-	Severe	7800	GypWall <b>EXTREME</b> (including EXTREME / ROBUST Hybrid)
60 - 120	137 - 238	61 - 65	53 - 59	Severe	6800	GypWall <b>QUIET SF</b>
30 - 90	102 - 208	49 - 63	48 - 55	Heavy - Severe	5700	GypWall <b>STAGGERED</b>
60 - 120	200 - 300	60 - 64	47 - 58	Severe	7500	GypWall <b>QUIET</b>
60 - 120	≥200	66 - 70	58 - 62	Severe	3900	GypWall <b>QUIET IWL</b>
60 - 120	300 - 800	67 - 80	56 - 71	Severe	11500	GypWall <b>AUDIO</b>
30 - 120	88 - 196	34 - 52	-	-	-	Non-loadbearing timber stud (internal partitions)
60 - 90	141 - 293	56 - 63	48 - 53	-	-	Non-loadbearing timber stud (separating walls)

<sup>1</sup> Based on studs at 600mm centres



### Additional information

Try out our **System Selector**, an online tool designed to help find the ideal solutions for your project needs. Additional information such as BIM data (e.g. Revit) and other associated items can be downloaded. Visit [gyproc.ie](https://gyproc.ie)

# GypWall performance

## Acoustic performance

Table 1 — Sound insulation performance for residential specification

Technical Guidance Document E (Republic of Ireland)	On-site
	$D_{nT,w}$ dB
Separating walls between new homes	53

Booklet G (Northern Ireland)	On-site
	$D_{nT,w} + C_{tr}$ dB
Separating walls between new dwellings	45 (43*)
Dwellings formed by a material change of use	43
	Walls
	Floors & Stairs

\*Hotel rooms, hostels, boarding houses or hall of residence

## Good practice specification guidance

Gyproc's systems are designed and tested to meet every performance requirement and are fully supported by our SpecSure® guarantee.

This means that when our systems are installed following our guidance they will achieve every performance claim we make, and if they don't then we'll put it right.

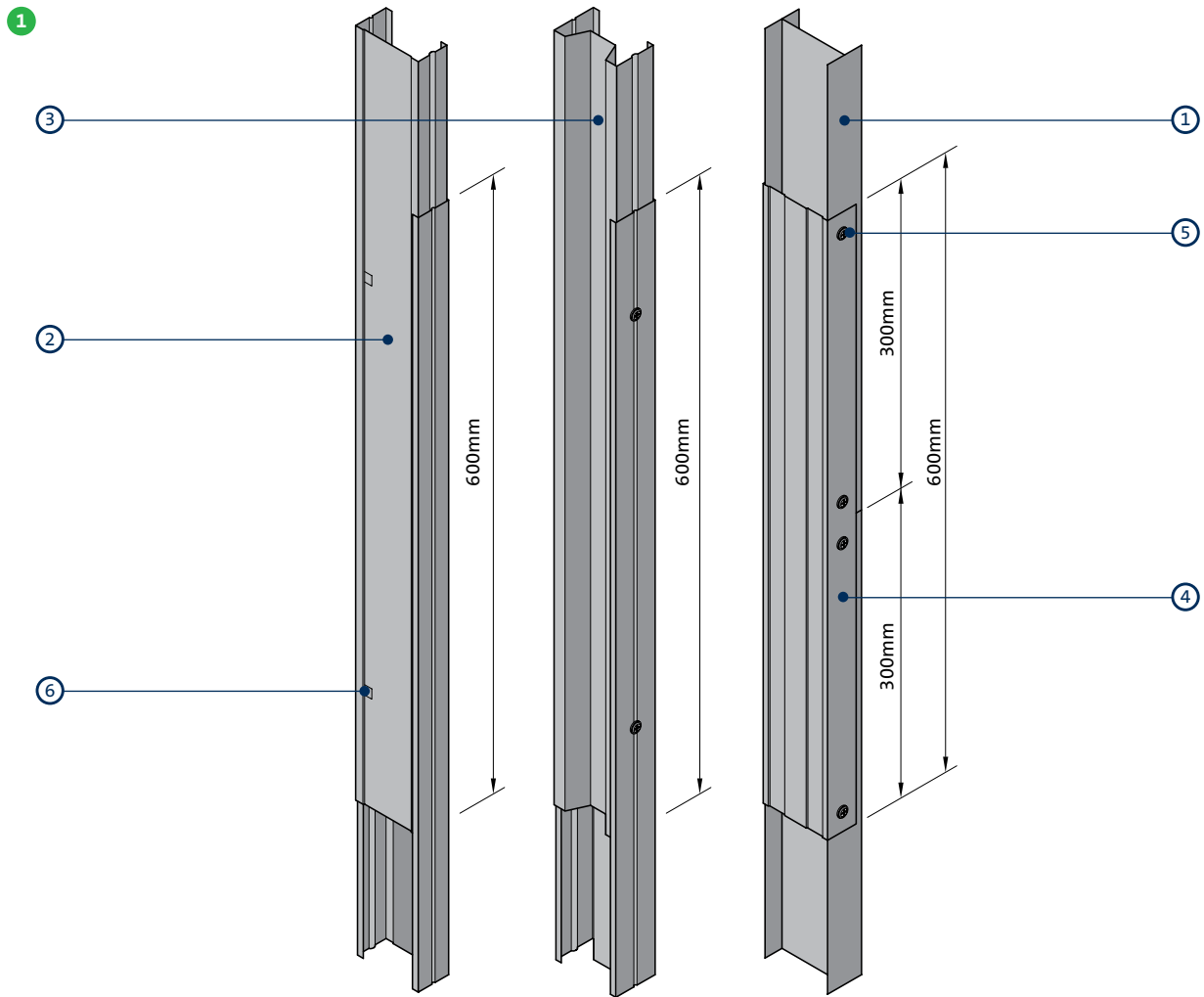
To maximise the performance achieved on site, consider the following good practice specification guidance:



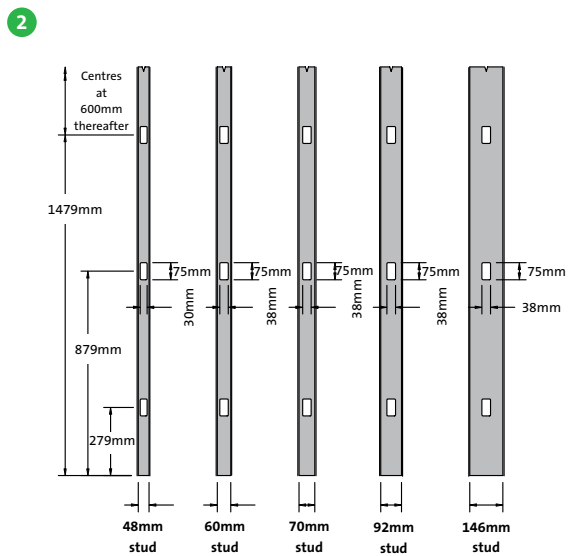
- Consider flanking transmission at the design stage and ensure construction detailing is specified to eliminate, or at least to minimise, any downgrading of the acoustic performance
- Small openings such as gaps, cracks or holes will conduct airborne sounds and can significantly reduce the sound insulation of a construction. For optimum sound insulation a construction must be airtight
- When designing the layout of rooms requiring separation by sound insulating walls abutting structural steelwork, consideration should be given to the potential loss of sound insulation performance through the steelwork
- Deflection heads, by definition, must be able to move and, therefore, achieving an airtight seal is very difficult without incorporating sophisticated components and techniques. Air leakage at the partition heads will have a detrimental effect on acoustic performance of any partition. Where acoustic performance is a key consideration, steps must be taken to minimise this loss of performance
- A common mistake made when designing a building is to specify a high performance element and then incorporate a lower performing element within it: although sometimes unavoidable, for example, a door within a partition. Where the difference between insulation is relatively small (7dB or less), there needs to be a comparatively large area of the lower insulation element before the overall sound insulation is significantly affected. However, where there is a greater difference in sound insulation performance between the two elements, this would usually result in a greater reduction of overall sound insulation performance.

# Standard GypWall construction details

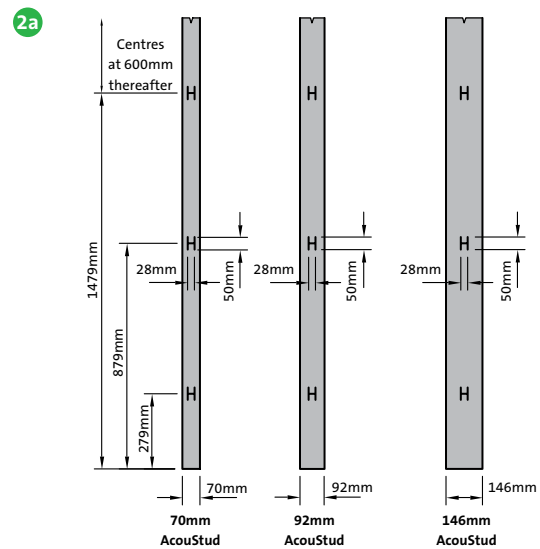
To be read in conjunction with system specific details. Refer to relevant system sections



Stud splicing detail



Service cut-outs - Gypframe 'C' and Gypframe 'I' Studs



Service cut-outs - Gypframe AcouStuds

- 1 Gypframe 'I' Stud
- 2 Gypframe 'C' Stud
- 3 Gypframe AcouStud

- 4 Gypframe Floor & Ceiling Channel
- 5 Gyproc Wafer Head Drywall Screws or Gyproc Wafer Head Jack-Point Screws
- 6 Crimp

## Fire protection

Plasterboard linings provide good fire protection owing to the unique behaviour of the non-combustible gypsum core when subjected to high temperatures.

### Fire resistance

Elements of structure such as compartment walls which are required by national Building Regulations to be constructed of non-combustible materials or 'materials of limited combustibility', should be installed without timber sole plates. All Gyproc metal stud partitions and walls are tested for fire resistance without timber sole plates. However, if a timber sole plate is included, the plasterboard linings should be fixed to protect the sole plate on either side.

Three high performance fire resistant boards are available from Gyproc – Gyproc FireLine, Gyproc Duraline and Gyproc MultiBoard.

Gyproc FireLine is a cost-effective fire resistant board suitable for use over a wide range of specifications.

Gyproc Duraline combines high levels of fire performance with high impact resistance. Gyproc MultiBoard is a general purpose building board offering high levels of fire performance, impact and moisture resistance. Its flexibility makes it ideal as a lining for curved partitions, walls and ceilings.

### Fire-stopping

Gaps around the perimeter of elements and inadequate sealing at junctions and around service penetrations can result in building elements failing to meet their specified levels of fire protection. The services themselves can also act as a mechanism of fire spread. By designing zones through which all services pass, the number of individual service penetrations can be minimised. Since most services are installed by specialist contractors, it is important that adequate liaison is maintained with the drylining contractor to ensure their proper location and firestopping. The necessity to independently support services will depend on their size and weight. Contact the Gyproc Technical Department for guidance.

## Sound insulation

To achieve optimum sound insulation it is important that the partition is made airtight. At the base of the partition gaps will occur particularly when boards are lifted tight to the ceiling. Small gaps or airpaths can be sealed using Gyproc Sealant. Most remaining gaps can be sealed at the jointing stage using Gyproc jointing materials. It is recommended that gaps in excess of 6mm are bulk filled using a Gyproc Jointing material after application of Gyproc Sealant (see Figs 3 and 3a).

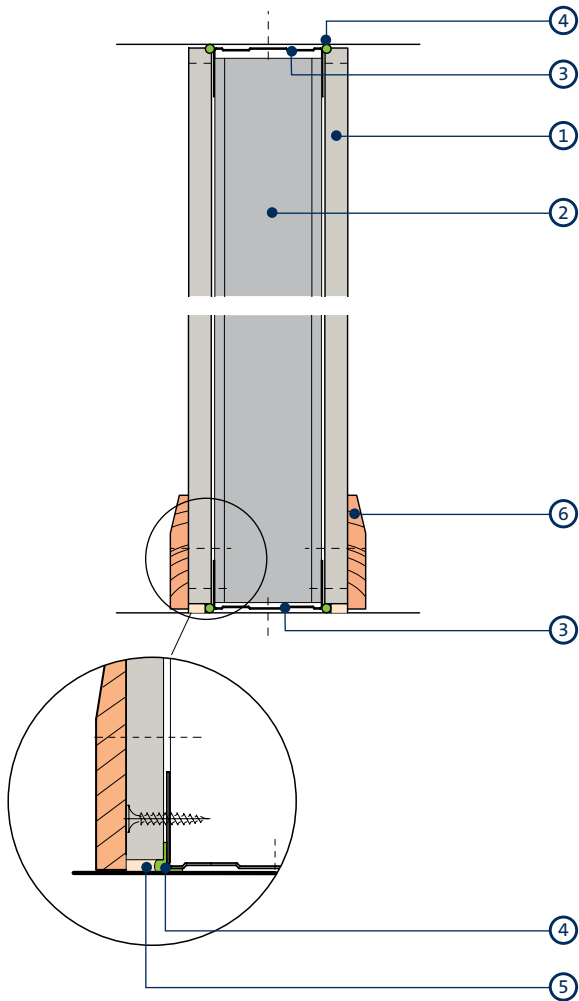
The standard of sound insulation achieved on site may be influenced by flanking transmission and direct transmission via doors, glazing, services, etc. Therefore, care should be taken to ensure that the associated structure is suitable to achieve the level of sound insulation required.

Where high levels of sound insulation are important, Gyproc SoundBloc offers significantly enhanced performance compared to the same thickness of Gyproc WallBoard.

## Standard GypWall construction details (continued)

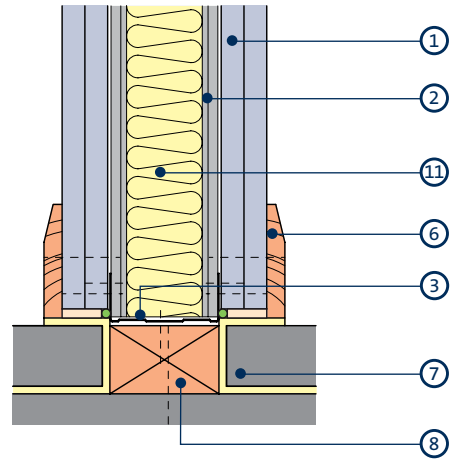
To be read in conjunction with system specific details. Refer to relevant system sections

3



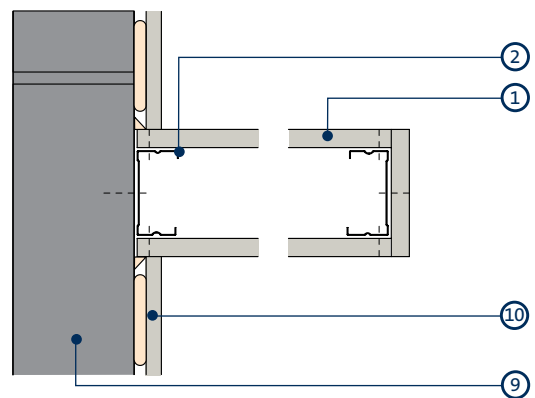
Head and base

3a



Base with timber sole plate

4



Junction with masonry and stop end detail

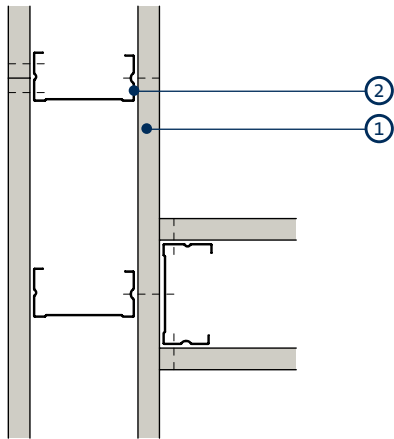
- 1 Gyproc plasterboard or Glasroc F specialist board
- 2 Gypframe 'C' Stud
- 3 Gypframe Floor & Ceiling Channel
- 4 Gyproc Sealant
- 5 Bulk fill Gyproc jointing materials (where gap exceeds 5mm)
- 6 Skirting

- 7 Floating screed on resilient layer
- 8 Timber sole plate suitably fixed to structure
- 9 Internal blockwork
- 10 **DriLyner** wall lining system
- 11 Isover insulation

## Standard GypWall construction details (continued)

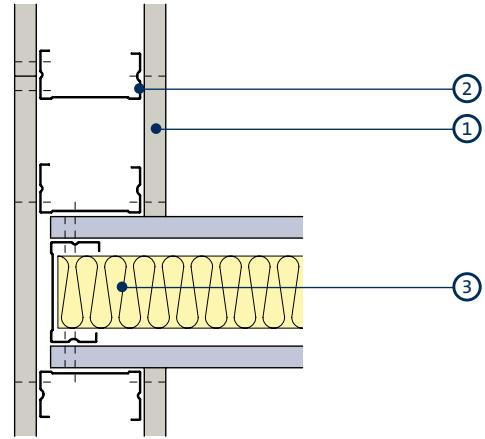
To be read in conjunction with system specific details. Refer to relevant system sections

5



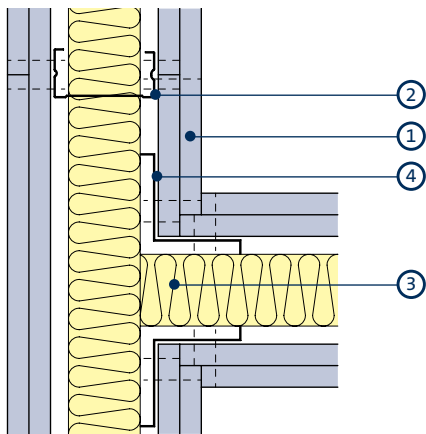
'T' junction - single layer

6



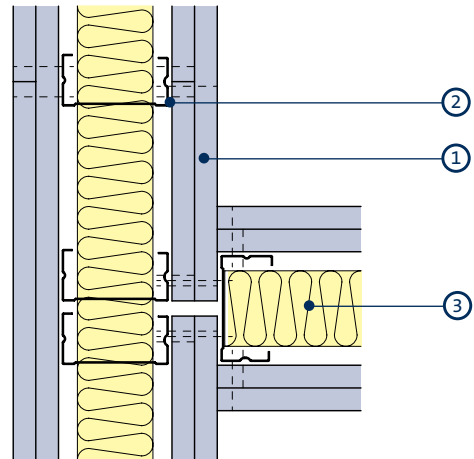
'T' Junction when partition with higher acoustic performance abuts a partition with lower acoustic performance. Acoustic principles only - detail may not be suitable for all solutions

7a



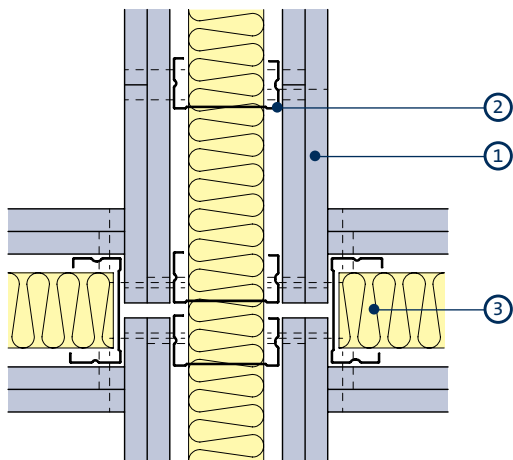
'T' junction to optimise acoustic performance and reduce flanking transmission

7b



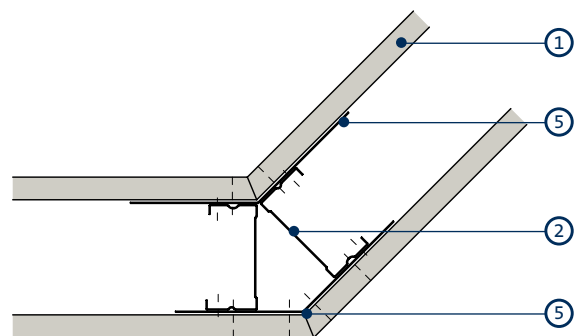
'T' junction to optimise acoustic performance and reduce flanking transmission

8



Four way junction to optimise acoustic performance and reduce flanking transmission

9



Splayed corner

1 Gyproc plasterboard or Glasroc F specialist board

2 Gypframe 'C' Stud

3 Isover insulation

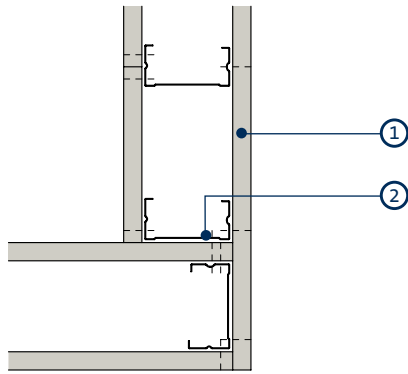
4 Gypframe GA5 Internal Fixing Angle

5 Gypframe GA6 Splayed Angle

## Standard GypWall construction details (continued)

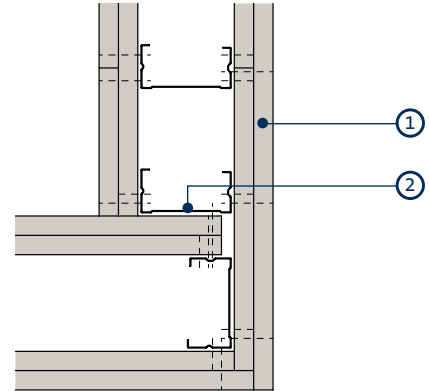
To be read in conjunction with system specific details. Refer to relevant system sections

10



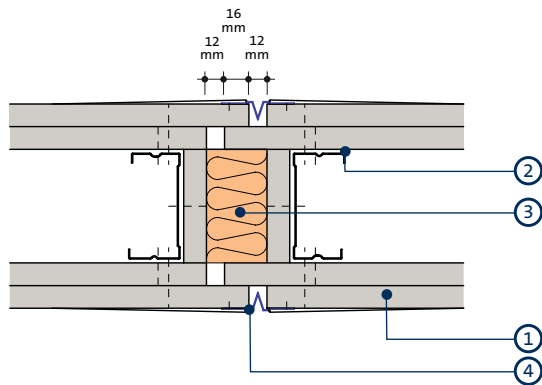
Corner detail - single layer

11



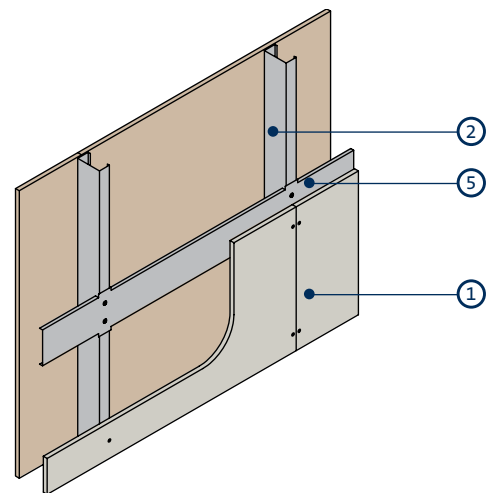
Corner detail - double layer

12



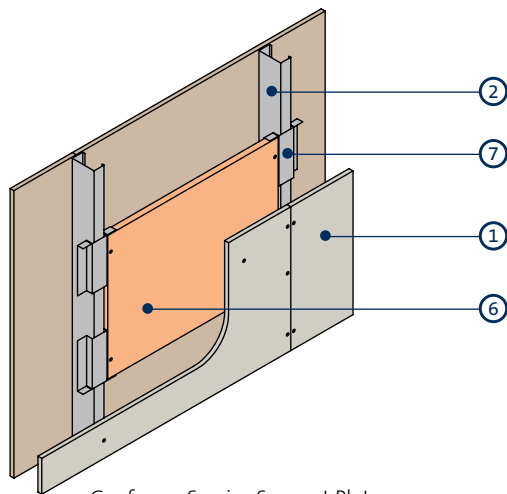
Typical control joint

13



Gypframe 99 FC 50 Fixing Channel  
(short legs flattened at stud positions)

14



Gypframe Service Support Plate

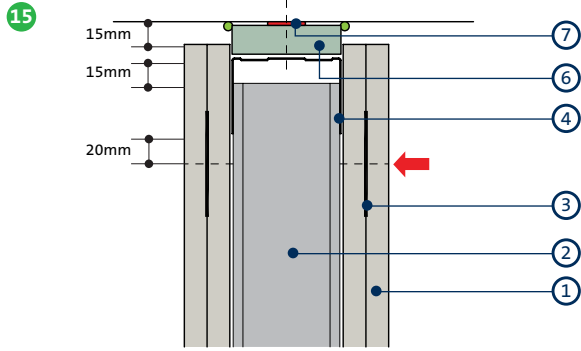
- 1 Gyproc plasterboard or Glasroc F specialist board
- 2 Gypframe 'C' Stud
- 3 Stone mineral wool (minimum density 23kg/m<sup>3</sup>) (by others)
- 4 Gyproc Control Joint

- 5 Gypframe 99 FC 50 Fixing Channel
- 6 18mm plywood
- 7 Gypframe Service Support Plate

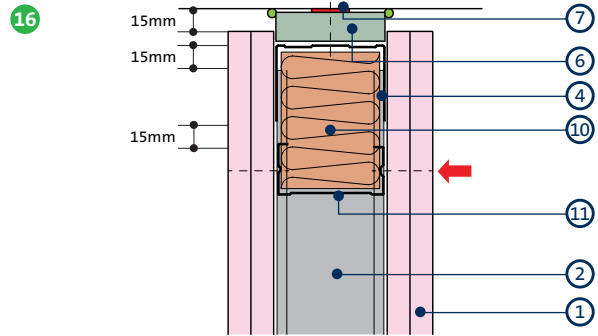
**NB** Installing the screw into the side of the Gypframe Service Support Plate and the web of the Gypframe 'C' Stud will avoid creating excessive distortion to the lining board.

## Standard GypWall construction details (continued)

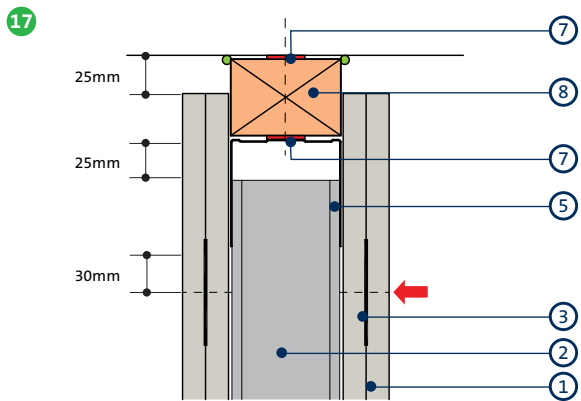
To be read in conjunction with system specific details. Refer to relevant system sections



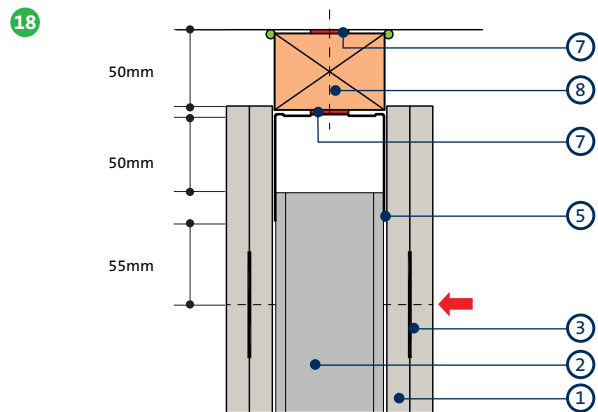
Deflection head for 15mm downward movement and 60 minutes fire resistance - BS 476 Part 22: 1987



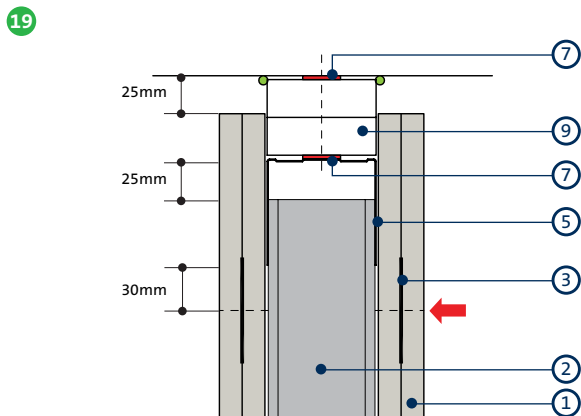
Deflection head for 15mm downward movement and up to 120 minutes fire resistance - BS 476 Part 22: 1987



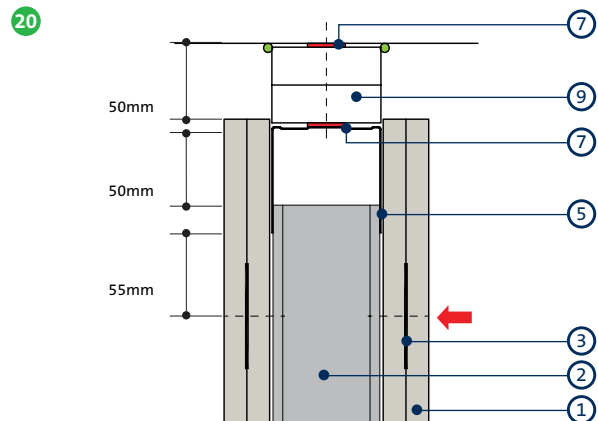
Deflection head for plus or minus 25mm movement and 60 minutes fire resistance - BS 476 Part 22: 1987



Deflection head for 50mm downward movement and 60 minutes fire resistance - BS 476 Part 22: 1987



Deflection head for plus or minus 25mm movement and 60 minutes fire resistance - BS 476 Part 22: 1987



Deflection head for 50mm downward movement and 60 minutes fire resistance - BS 476 Part 22: 1987

1 Gyproc plasterboard or Glasroc F specialist board

2 Gypframe 'C' Stud

3 Gypframe GF51 Fixing Strap

4 Gypframe Deep Flange Floor & Ceiling Channel

5 Gypframe Extra Deep Flange Floor & Ceiling Channel

6 Gyproc CoreBoard

7 Gyproc FireStrip (continuous)

8 Timber head plate suitably fixed to structure

9 25mm Glasroc F FIRECASE

10 Stone mineral wool (by others)

11 Nogging cut from Gypframe 'C' Stud

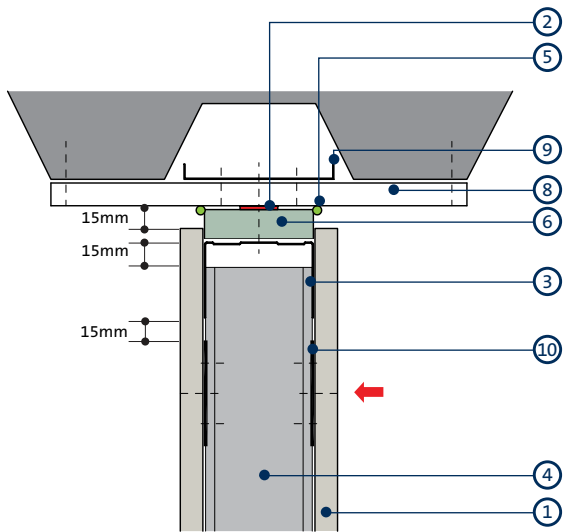
Detail updates July 2024 highlight requirements for cloaking to be applied to deflection heads on any partitions tested to EN 1364-1. Please contact technical department for details.

**NB** No fixings should be made through the boards into the flanges of the head channel. The arrow (↔) denotes the position of the uppermost board fixing, which should be made into Gypframe GF51 Fixing Strap (or stud nogging in construction detail 16). Continuous Gyproc FireStrip must be installed as shown to maintain fire performance. Where there is a need for a deflection head in a 90 minute wall, the 120 minute solution can be used (refer to construction detail 16) or alternatively, please contact the Gyproc Technical Department for further guidance.

## Standard GypWall construction details (continued)

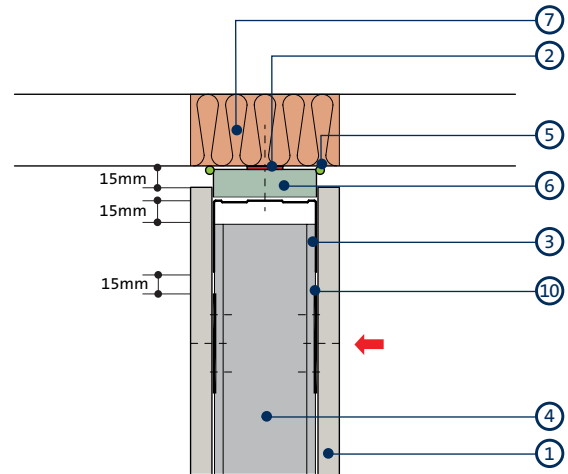
To be read in conjunction with system specific details. Refer to relevant system sections

21



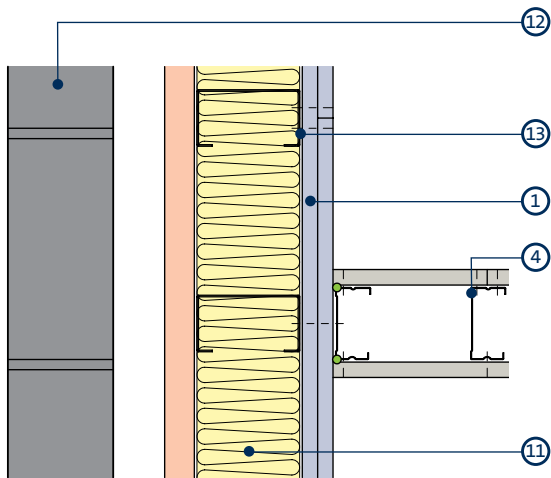
Deflection head parallel to floor profile for 15mm downward movement and up to 60 minutes fire resistance<sup>1</sup>  
- BS 476 Part 22: 1987

22



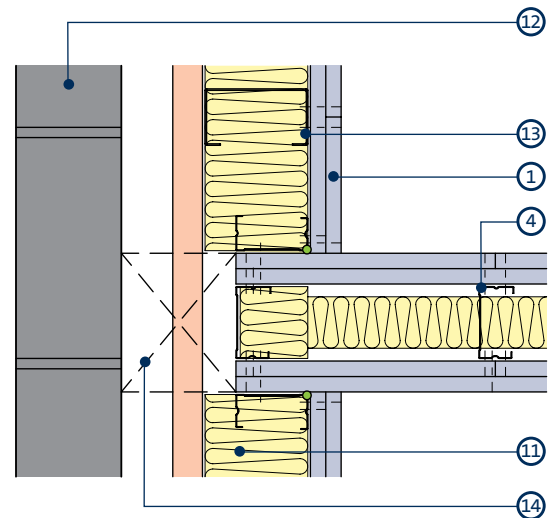
Deflection head perpendicular to floor profile for 15mm downward movement and up to 60 minutes fire resistance  
- BS 476 Part 22: 1987

23



Junction with external wall  
Acoustic principles only. Fire performance of structural metal wall by others

24



Junction with external wall when acoustic performance is a key consideration - helps reduce flanking transmission. Acoustic principles only. Fire performance of structural metal wall by others

- 1 Gyproc plasterboard or Glasroc F specialist board
- 2 Gyproc FireStrip (continuous line)
- 3 Gypframe Deep Flange Floor & Ceiling Channels (DC)
- 4 Gypframe 'C' Stud
- 5 Gyproc Sealant
- 6 Gyproc CoreBoard
- 7 Fire-stopping (by others)
- 8 Glasroc F FIRECASE

- 9 Gypframe 99 FC 50 Fixing Channel
- 10 Gypframe GFS1 Fixing Strap fixed to studs with Gyproc Wafer Head Drywall Screws
- 11 Isover insulation
- 12 External facade
- 13 External wall frame stud / by other(s)
- 14 Cavity barrier (subject to regulatory requirements)

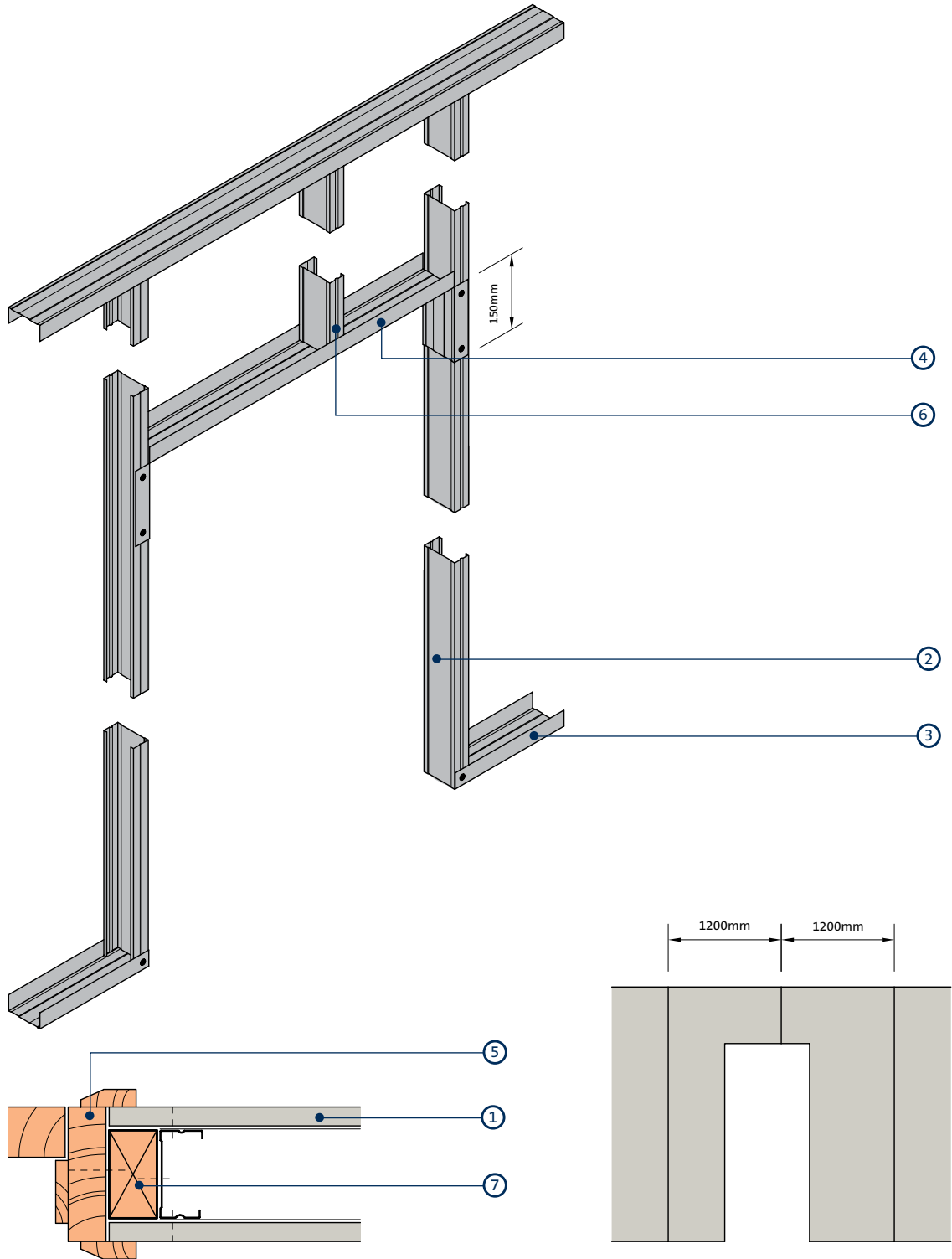
**NB** No fixings should be made through the boards into the flanges of the head channel. The arrow (←) denotes the position of the uppermost board fixing, which should be made into Gypframe GFS1 Fixing Strap. Continuous Gyproc FireStrip must be installed as shown to maintain fire performance.

<sup>1</sup> To minimise acoustic downgrade, install Isover insulation within the hollow rib void.

## Standard GypWall construction details (continued)

To be read in conjunction with system specific details. Refer to relevant system sections

25



Door frame (maximum 1200mm width) to satisfy BS 5234: Parts 1 & 2: 1992 - Light and Medium Duty (up to 35kg door)

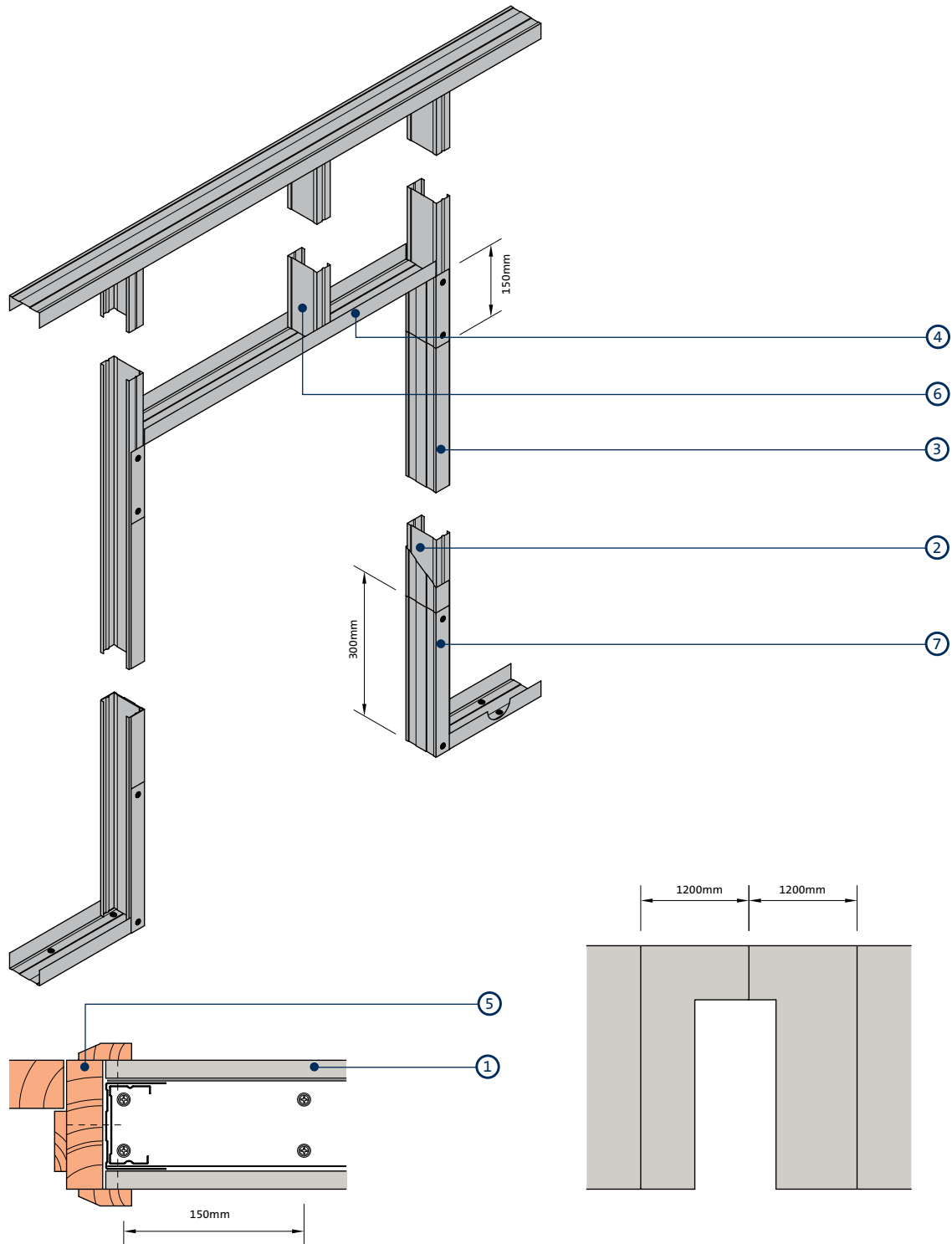
- |   |   |
|---|---|
| 1 Gyproc plasterboard or Glasroc F specialist board               | 5 Timber door frame and architrave          |
| 2 Gypframe 'C' Stud   | 6 Gypframe 'C' Stud to maintain stud module |
| 3 Gypframe Floor & Ceiling Channel                                | 7 Timber sub-frame                          |
| 4 Gypframe Floor & Ceiling Channel cut and bent to form door head |   |

**NB** Advice should be sought from the door manufacturer prior to the construction of these details.

## Standard GypWall construction details (continued)

To be read in conjunction with system specific details. Refer to relevant system sections

26



Door frame (maximum 1200mm width) to satisfy BS 5234: Parts 1 & 2: 1992 - Heavy and Severe Duty (60kg door)

- |   |  |
|---|--|
| 1 Gyproc plasterboard or Glasroc F specialist board               | 5 Timber door frame and architrave                                 |
| 2 Gypframe 'C' Stud   | 6 Gypframe 'C' Stud to maintain stud module                        |
| 3 Gypframe Floor & Ceiling Channel to sleeve studs                | 7 Gypframe Floor & Ceiling Channel cut and bent to extend up studs |
| 4 Gypframe Floor & Ceiling Channel cut and bent to form door head |  |

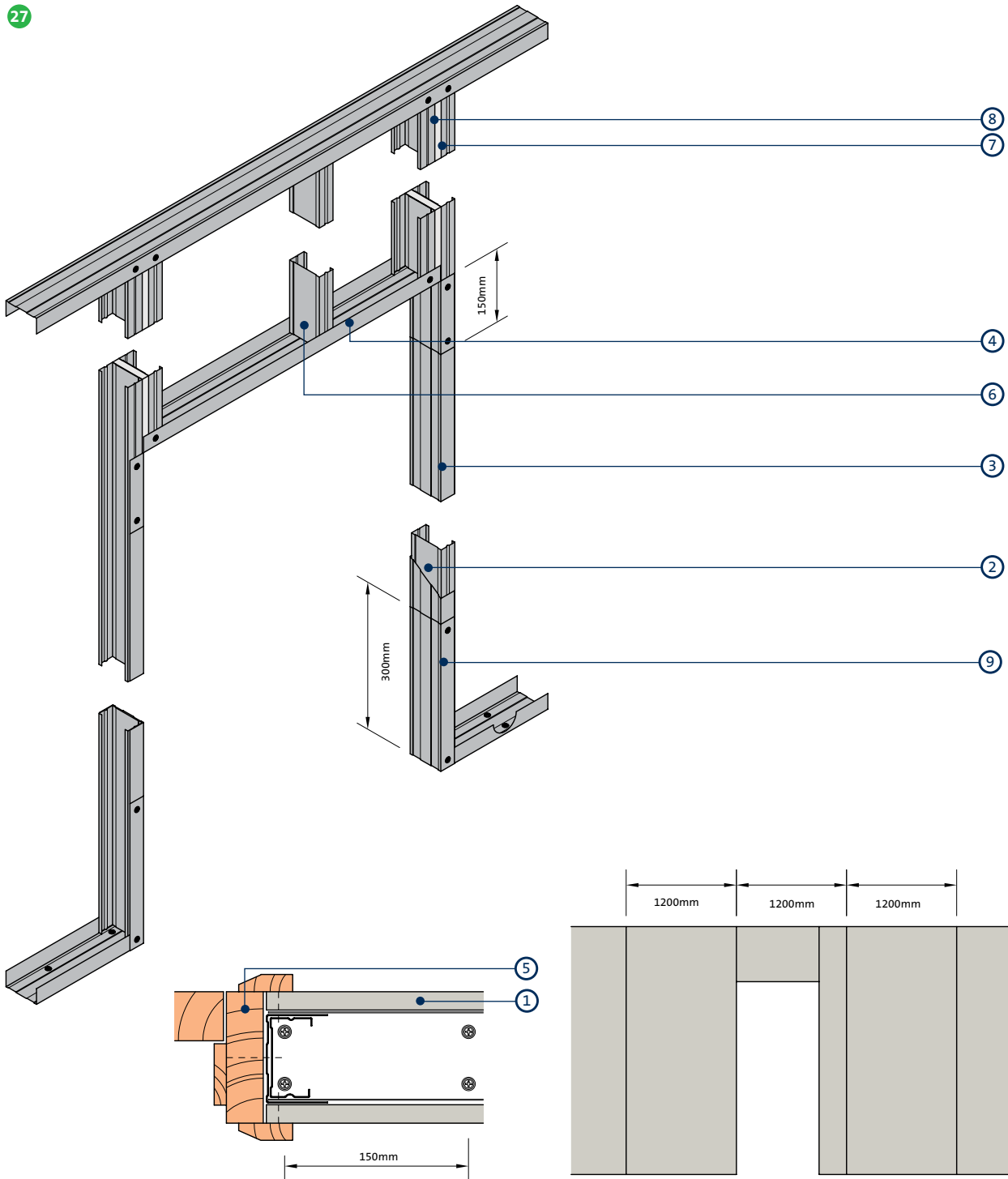
**NB** Advice should be sought from the door manufacturer prior to the construction of these details.

**NB** At the base, the channel is cut and bent to extend 300mm up the studs and fixed each side with two Gyproc Wafer Head Drywall Screws. The studs each side of the opening are sleeved full height of opening with Gypframe Floor & Ceiling Channel.

## Standard GypWall construction details (continued)

To be read in conjunction with system specific details. Refer to relevant system sections

27



Alternative door frame for fixed partition heads only (maximum 1200mm width) to satisfy  
BS 5234: Parts 1 & 2: 1992 - Heavy and Severe Duty (60kg door)

- |   |   |
|---|---|
| 1 Gyproc plasterboard or Glasroc F specialist board               | 6 Gypframe 'C' Stud to maintain stud module   |
| 2 Gypframe 'C' Stud   | 7 Gypframe 'C' Studs fixed back to back with Gyproc Drywall Screws at 300mm centres staggered |
| 3 Gypframe Floor & Ceiling Channel to sleeve studs                | 8 Plasterboard infill (same type as lining) cut to fit between studs                          |
| 4 Gypframe Floor & Ceiling Channel cut and bent to form door head | 9 Gypframe Floor & Ceiling Channel cut and bent to extend up studs                            |
| 5 Timber door frame and architrave                                |   |

**NB** Advice should be sought from the door manufacturer prior to the construction of these details.

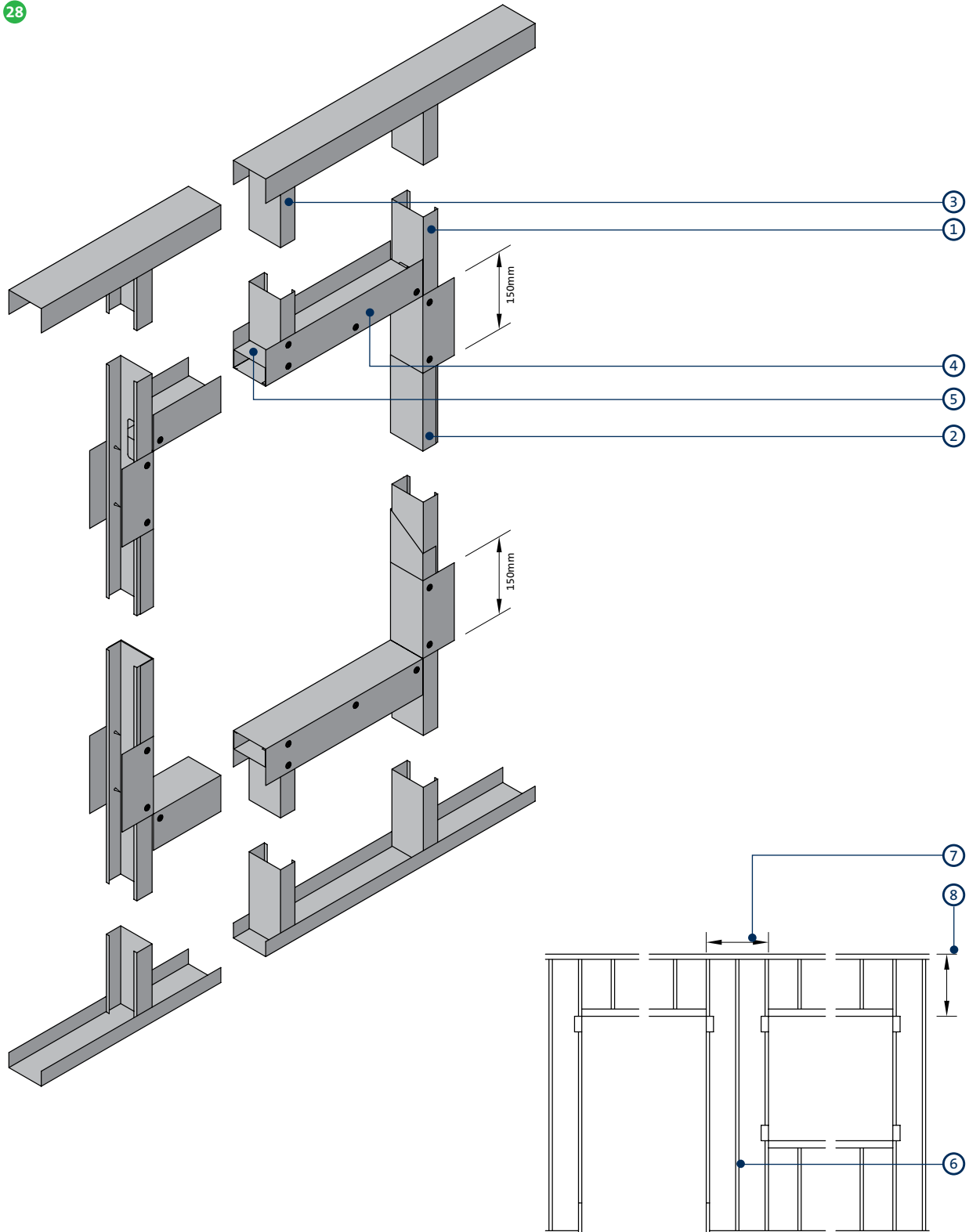
**NB** At the base, the channel is cut and bent to extend 300mm up the studs and fixed each side with two Gyproc Wafer Head Drywall Screws. The studs each side of the opening are sleeved full height of opening with Gypframe Floor & Ceiling Channel.

**NB** The principle of this alternative detail is only suitable for GypWall, GypWall **ROBUST** and GypWall **EXTREME** for fixed head situations only.

## Standard GypWall construction details (continued)

To be read in conjunction with system specific details. Refer to relevant system sections

28



Openings 1201 - 3300mm wide, for example double doors or large windows

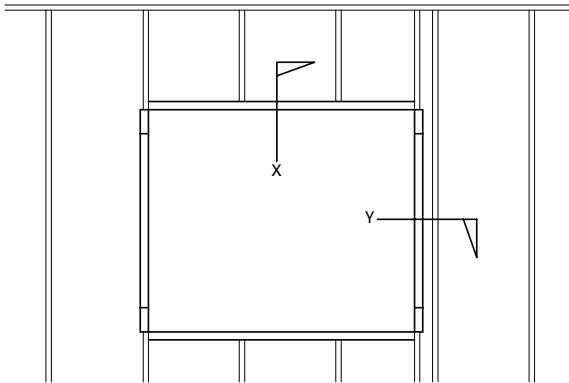
- |   |   |
|---|---|
| 1 Gypframe 'C' Stud   | 6 Centre stud required for margin up to 600mm between openings  |
| 2 Stud sleeved to full opening height with Gypframe Floor & Ceiling Channel | 7 Partition between openings, minimum 600mm for Gypframe 'C' Studs (minimum 300mm for Gypframe 'T' Studs) |
| 3 Gypframe studs (appropriate to system)                                    | 8 Maximum distance 2400mm (if exceeds 2400mm contact Gyproc Technical Department)                         |
| 4 Gypframe Extra Deep Flange Floor & Ceiling Channel                        |   |
| 5 Gypframe stud insert  |   |

## Standard GypWall construction details (continued)

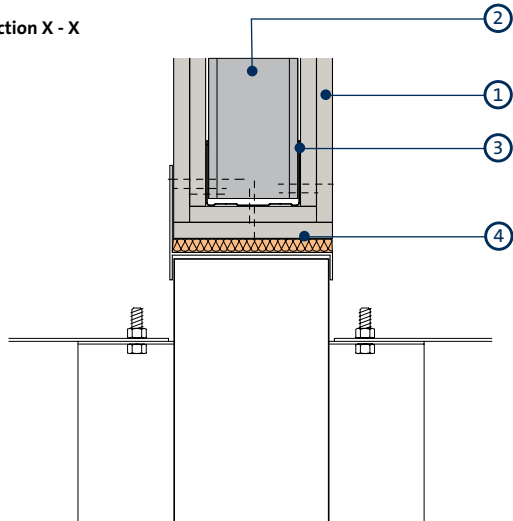
To be read in conjunction with system specific details. Refer to relevant system sections

29

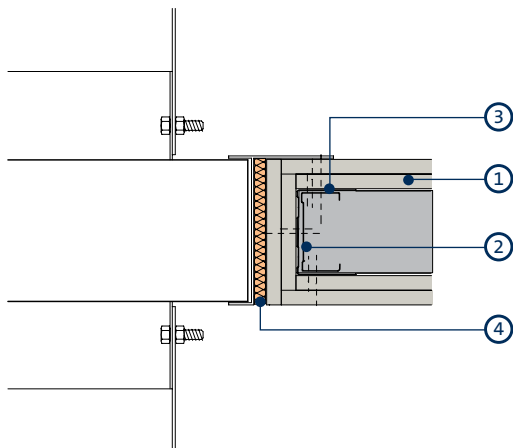
### Elevation



### Section X - X

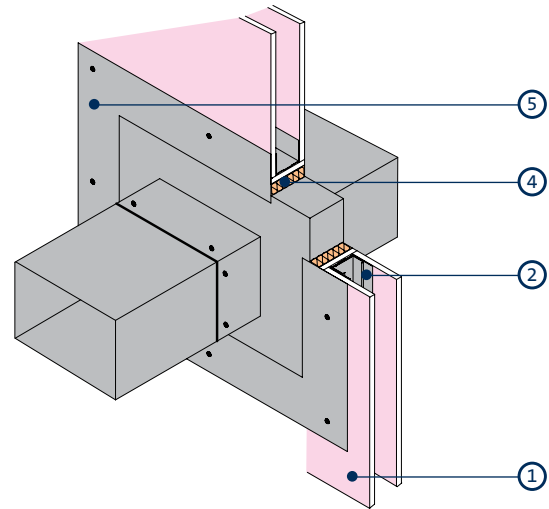


### Section Y - Y



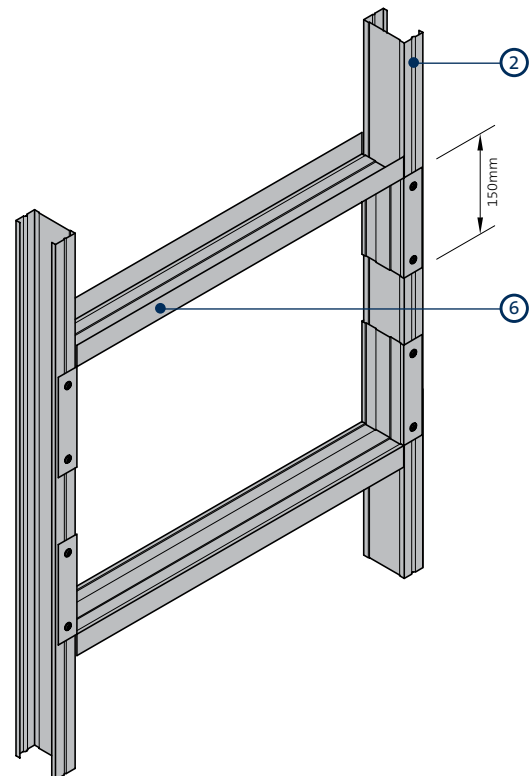
Opening for service penetrations in fire-rated partitions

30



Fire tested construction in which the damper is supported by the partition (isometric view)

31



Opening up to 600mm wide for services

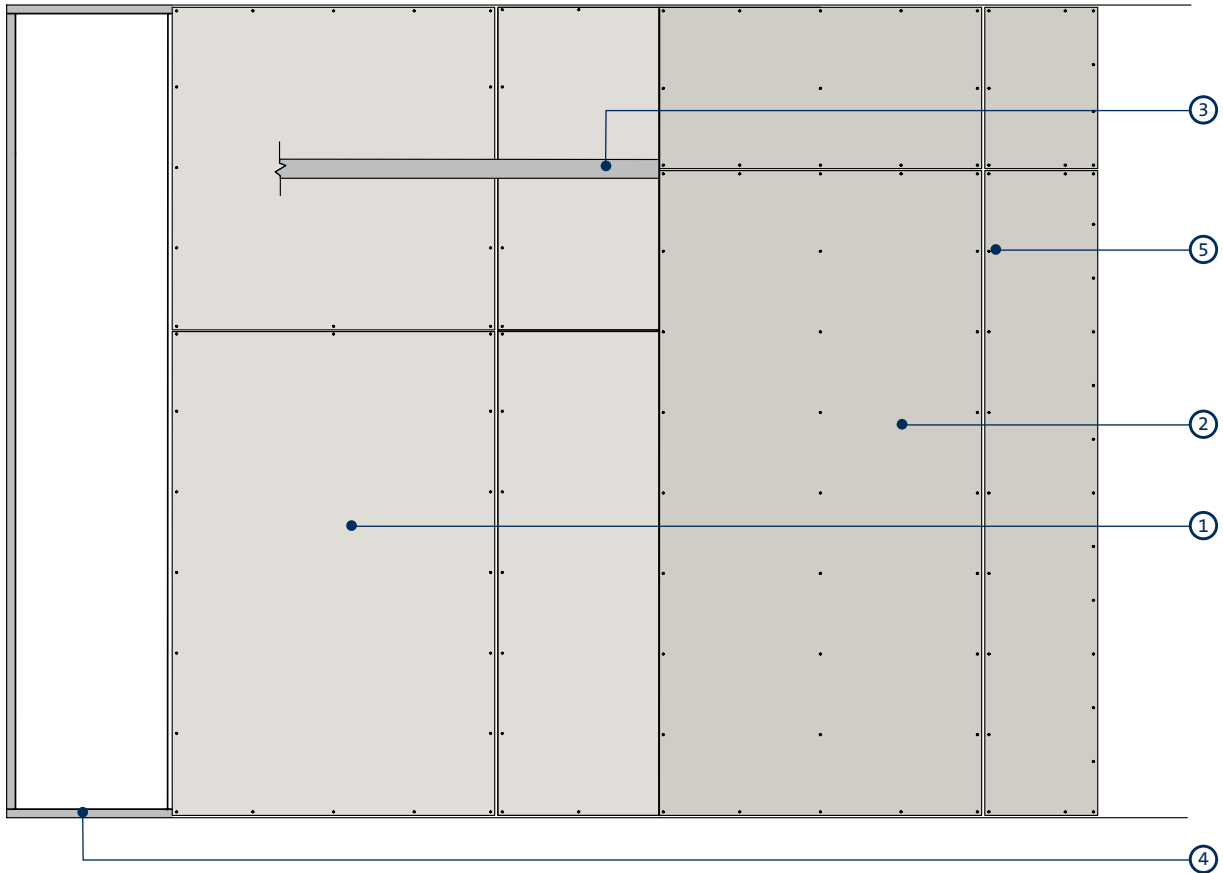
- 1 Gyproc plasterboard or Glasroc F specialist board
- 2 Gypframe 'C' Stud
- 3 Gypframe Floor & Ceiling Channel
- 4 Penetration seal if required (refer to damper manufacturer for details)

- 5 Damper (by others). Weight of damper should not exceed 57kg. Size of damper should not exceed 1400 x 1200mm
- 6 Gypframe Folded Edge Standard Floor & Ceiling Channel cut and bent to form opening head and cill

## Standard GypWall construction details (continued)

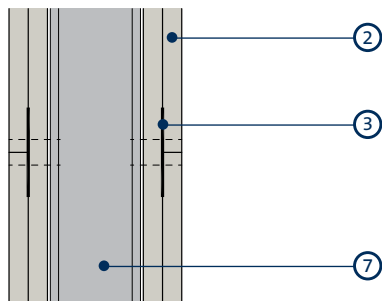
To be read in conjunction with system specific details. Refer to relevant system sections

32



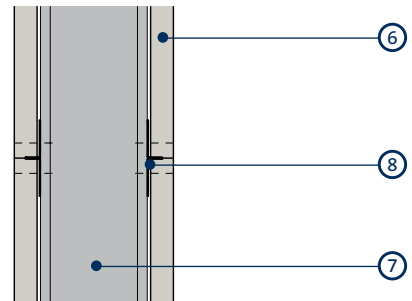
Board layout - typical configuration

33



Horizontal board joint - double layer

34



Horizontal board joint - single layer

- 1 Inner layer of Gyproc plasterboard or Glasroc F specialist board
- 2 Outer layer of Gyproc plasterboard or Glasroc F specialist board
- 3 Gypframe GFS1 Fixing Strap
- 4 Gypframe metal framing

- 5 Gyproc Drywall Screws
- 6 Gyproc plasterboard or Glasroc F specialist board
- 7 Gypframe 'C' Stud
- 8 Gypframe GFT1 Fixing T (alternatively use Gypframe GSF1 Fixing Strap)



# GypWall

A highly versatile metal stud partition system

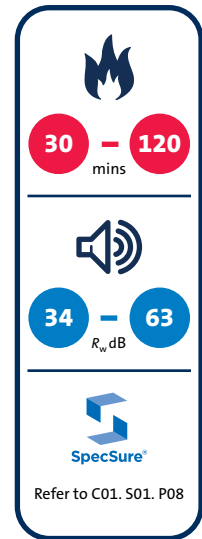


# GypWall

**GypWall** is the industry's original lightweight non-loadbearing drywall partition system, providing cost-effective, multi-purpose solutions suitable for all types of buildings.

## Key benefits

- Wide range of performances achievable through a combination of interchangeable Gyproc plasterboards, Gypframe metal, Gyproc finish plasters and Isover insulation
- Optimised acoustic performance for a given footprint through the use of Gypframe AcouStuds
- Quick to install compared to masonry or timber frame alternatives and allows transformation of building layouts with minimal disruption
- Non-hygroscopic Gypframe metal framework will not twist, warp or rot
- Easy accommodation of services within the stud cavity due to pre-cut service holes within the Gypframe metal studs



## You may also be interested in...

### GypWall **ROBUST**

Need a higher Duty Rating to *BS 5234*? GypWall **ROBUST** provides Severe Duty Rating with a single layer of board.

► Refer to C04. S03. P157.

### ShaftWall

Where access is limited to one side only, for example risers, lift shafts, corridors and stair cores, ShaftWall provides the answer.

► Refer to C05. S02. P291.

# GypWall performance

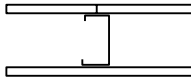
## 48mm Gypframe 'C' Studs - single layer board linings

For details of when to specify fire resistance using EN  
 ▶ Refer to C02. S01. P18



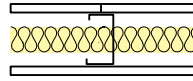
Table 1a — Solutions to satisfy the requirements of BS EN 1364-1: 1999

①



One layer of board each side of 48mm Gypframe 'C' Studs at 600mm centres. Linings as in table.

②



One layer of board each side of 48mm Gypframe 'C' Studs at 600mm centres. 25mm Isovex Acoustic Roll in the cavity. Linings as in table.

▶ Refer to GypWall ROBUST and GypWall EXTREME sections for single layer Severe Duty solutions

Detail	Partition thickness mm	Board type	Lining thickness mm	Max height <sup>1</sup> mm	Sound insulation R <sub>w</sub> dB		Duty rating	Approx. weight kg/m <sup>2</sup>	System reference	
					Any <sup>2</sup> finish	Skim <sup>3</sup> only			Any <sup>2</sup> finish	Skim <sup>3</sup> only
<b>30 minutes fire resistance</b> (EN)										
①	75	Gyproc WallBoard	1 x 12.5	2500	34	-	Medium	18	A206001	-
①	75	Glasroc H TILEBACKER	1 x 12.5	2500	34	-	Medium	22	H206001	-
①	75	Gyproc SoundBloc	1 x 12.5	2500	37	-	Medium	22	A206152	-
②	75	Gyproc WallBoard	1 x 12.5	2500	40	-	Medium	18	A206033	-
②	75	Glasroc H TILEBACKER	1 x 12.5	2500	40	-	Medium	22	H206033	-
②	75	Gyproc SoundBloc	1 x 12.5	2500	43	-	Medium	22	A206184	-
①	80	Gyproc WallBoard	1 x 15	2800	36	-	Medium	22	A206002	-
①	80	Gyproc SoundBloc	1 x 15	2800	39	-	Medium	26	A206153	-
②	80	Gyproc WallBoard	1 x 15	2800	42	-	Medium	22	A206034	-
②	80	Gyproc SoundBloc	1 x 15	2800	44	45	Medium	26	A206185	A206185S
<b>60 minutes fire resistance</b> (EN)										
①	75	Glasroc F MULTIBOARD	1 x 12.5	2500	36	-	Severe	25	G106010	-
①	80	Gyproc FireLine	1 x 15	2800	36	-	Heavy	24	A206066	-
②	80	Gyproc FireLine	1 x 15	2800	42	-	Heavy	24	A206098	-

▶ For further assistance in choosing the right solution for your project, try our System Selector; an online tool that enables quick and easy filtering by performance criteria. It provides system specific information downloads including BIM (Revit) objects. Go to [gyproc.ie](http://gyproc.ie)

<sup>1</sup>The maximum heights quoted are limited by the fire state field of application or by limiting deflection of L/240 at 200 Pa, whichever is the more onerous.

<sup>2</sup>Sound insulation performance for partitions finished using jointing or plaster skim.

<sup>3</sup>Sound insulation performance for partitions finished with a 2mm skim finish of Gyproc Skimcoat, Carlite Finish or Carlite Ultra Finish plaster.

**(NB)** The fire resistance and sound insulation performances are for imperforate partitions, walls and ceilings incorporating boards with all joints taped and filled, or skimmed according to Gyproc's recommendations. The quoted performances are achieved only if Gyproc and Isovex components are used throughout, and the Company's fixing recommendations are strictly observed. Any variation in the specifications should be checked with Gyproc.

## GypWall performance (continued)

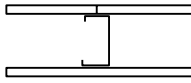
### 48mm Gypframe 'C' Studs - single layer board linings

For details of when to specify fire resistance using BS  
 ▶ Refer to C02. S01. P18



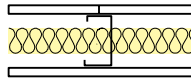
Table 1b — Solutions to satisfy the requirements of BS 476: Part 22: 1987

①



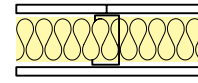
One layer of board each side of 48mm Gypframe 'C' Studs at 600mm centres. Linings as in table.

②



One layer of board each side of 48mm Gypframe 'C' Studs at 600mm centres. 25mm Isover Acoustic Roll in the cavity. Linings as in table.

③



One layer of board each side of 48mm Gypframe 'C' Studs at 600mm centres. 50mm Isover Acoustic Roll in the cavity. Linings as in table.

▶ Refer to GypWall ROBUST and GypWall EXTREME sections for single layer Severe Duty solutions

Detail	Partition thickness mm	Board type	Lining thickness mm	Max height <sup>1</sup> mm	Sound insulation $R_w$ dB		Duty rating	Approx. weight kg/m <sup>2</sup>	System reference	
					Any <sup>2</sup> finish	Skim <sup>3</sup> only			Any <sup>2</sup> finish	Skim <sup>3</sup> only
<b>30 minutes fire resistance</b> (BS)										
①	70	Glasroc F MULTIBOARD	1 x 10	2500	35	-	Heavy	20	G106006	-
①	75	Gyproc WallBoard	1 x 12.5	2500	34	-	Medium	18	A206001	-
①	75	Glasroc H TILEBACKER	1 x 12.5	2500	34	-	Medium	22	H206001	-
①	75	Gyproc SoundBloc	1 x 12.5	2500	37	-	Medium	22	A206152	-
②	75	Gyproc WallBoard	1 x 12.5	2500	40	-	Medium	18	A206033	-
②	75	Glasroc H TILEBACKER	1 x 12.5	2500	40	-	Medium	22	H206033	-
②	75	Gyproc SoundBloc	1 x 12.5	2500	43	-	Medium	22	A206184	-
①	80	Gyproc WallBoard	1 x 15	2800	36	-	Medium	22	A206002	-
①	80	Gyproc SoundBloc	1 x 15	2800	39	-	Medium	26	A206153	-
②	80	Gyproc WallBoard	1 x 15	2800	42	-	Medium	22	A206034	-
②	80	Gyproc SoundBloc	1 x 15	2800	44	45	Medium	26	A206185	A206185S
<b>60 minutes fire resistance</b> (BS)										
③	70	Glasroc F MULTIBOARD	1 x 10	2500	43	-	Heavy	20	G106008	-
①	75	Glasroc F MULTIBOARD	1 x 12.5	2500	36	-	Severe	25	G106010	-
①	80	Gyproc FireLine	1 x 15	2800	36	-	Heavy	24	A206066	-
②	80	Gyproc FireLine	1 x 15	2800	42	-	Heavy	24	A206098	-

▶ For further assistance in choosing the right solution for your project, try our System Selector; an online tool that enables quick and easy filtering by performance criteria. It provides system specific information downloads including BIM (Revit) objects. Go to [gyproc.ie](http://gyproc.ie)

<sup>1</sup> Based on a limiting deflection of L/240 at 200 Pa. Greater heights can be achieved through the use of Gypframe 'I' Studs, or reduced stud centres.

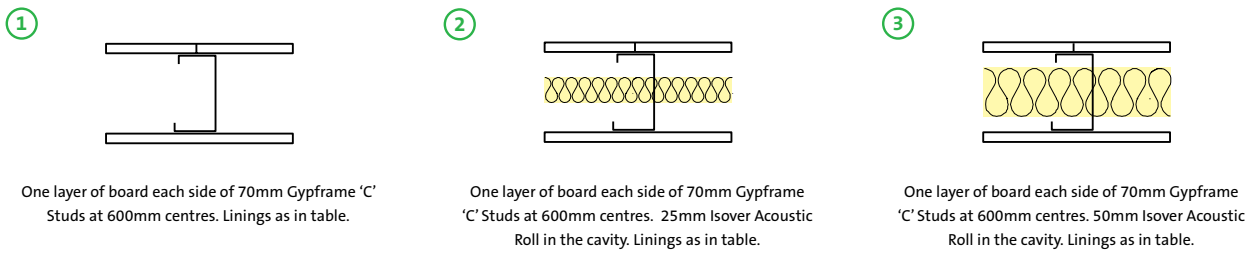
<sup>2</sup> Sound insulation performance for partitions finished using jointing or plaster skim.

<sup>3</sup> Sound insulation performance for partitions finished with a 2mm skim finish of Gyproc Skimcoat, Carlite Finish or Carlite Ultra Finish plaster.

**(NB)** The fire resistance and sound insulation performances are for imperforate partitions, walls and ceilings incorporating boards with all joints taped and filled, or skimmed according to Gyproc's recommendations. The quoted performances are achieved only if Gyproc and Isover components are used throughout, and the Company's fixing recommendations are strictly observed. Any variation in the specifications should be checked with Gyproc.



Table 2a — Solutions to satisfy the requirements of BS EN 1364-1: 1999



Refer to GypWall ROBUST and GypWall EXTREME sections for single layer Severe Duty solutions

Detail	Partition thickness mm	Board type	Lining thickness mm	Max height <sup>1</sup> mm	Sound insulation <sub>w</sub> dB		Duty rating	Approx. weight kg/m <sup>2</sup>	System reference	
					Any <sup>2</sup> finish	Skim <sup>3</sup> only			Any <sup>2</sup> finish	Skim <sup>3</sup> only
<b>30 minutes fire resistance</b> (EN)										
①	97	Gyproc WallBoard	1 x 12.5	3600	36	-	Medium	18	A206013	-
①	97	Glasroc H TILEBACKER	1 x 12.5	3600	36	-	Medium	22	H206013	-
①	97	Gyproc SoundBloc	1 x 12.5	3600	40	-	Medium	22	A206164	-
②	97	Gyproc WallBoard	1 x 12.5	3600	42	-	Medium	18	A206045	-
②	97	Glasroc H TILEBACKER	1 x 12.5	3600	42	-	Medium	22	H206045	-
③	97	Gyproc WallBoard	1 x 12.5	3600	43	-	Medium	19	A206138	-
③	97	Glasroc H TILEBACKER	1 x 12.5	3600	43	-	Medium	23	H206138	-
②	97	Gyproc SoundBloc	1 x 12.5	3600	45	-	Medium	22	A206196	-
③	97	Gyproc SoundBloc	1 x 12.5	3600	47	-	Medium	22	A206228	-
①	102	Gyproc WallBoard	1 x 15	3800	38	39	Medium	22	A206014	A206014S
①	102	Gyproc SoundBloc	1 x 15	3800	42	-	Heavy	26	A206165	-
②	102	Gyproc WallBoard	1 x 15	3800	43	44	Medium	22	A206046	A206046S
③	102	Gyproc WallBoard	1 x 15	3800	44	45	Medium	22	A206139	A206139S
②	102	Gyproc SoundBloc	1 x 15	3800	47	48	Heavy	26	A206197	A206197S
<b>60 minutes fire resistance</b> (EN)										
①	102	Gyproc FireLine	1 x 15	3800	37	-	Heavy	24	A206078	-
②	102	Gyproc FireLine	1 x 15	3800	43	44	Heavy	24	A206110	A206110S
③	102	Gyproc FireLine	1 x 15	3800	44	45	Heavy	24	A206141	A206141S

For further assistance in choosing the right solution for your project, try our System Selector; an online tool that enables quick and easy filtering by performance criteria. It provides system specific information downloads including BIM (Revit) objects. Go to [gyproc.ie](http://gyproc.ie)

<sup>1</sup> The maximum heights quoted are limited by the fire state field of application or by limiting deflection of L/240 at 200 Pa, whichever is the more onerous.

<sup>2</sup> Sound insulation performance for partitions finished using jointing or plaster skim.

<sup>3</sup> Sound insulation performance for partitions finished with a 2mm skim finish of Gyproc Skimcoat, Carlite Finish or Carlite Ultra Finish plaster.

**(NB)** The fire resistance and sound insulation performances are for imperforate partitions, walls and ceilings incorporating boards with all joints taped and filled, or skimmed according to Gyproc's recommendations. The quoted performances are achieved only if Gyproc and Isover components are used throughout, and the Company's fixing recommendations are strictly observed. Any variation in the specifications should be checked with Gyproc.

## GypWall performance (continued)

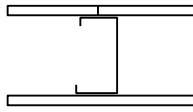
### 70mm Gypframe 'C' Studs - single layer board linings

For details of when to specify fire resistance using BS  
 ▶ Refer to C02. S01. P18



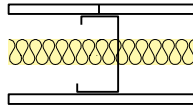
Table 2b — Solutions to satisfy the requirements of BS 476: Part 22: 1987

①



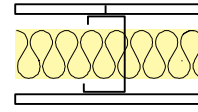
One layer of board each side of 70mm Gypframe 'C' Studs at 600mm centres. Linings as in table.

②



One layer of board each side of 70mm Gypframe 'C' Studs at 600mm centres. 25mm Isover Acoustic Roll in the cavity. Linings as in table.

③



One layer of board each side of 70mm Gypframe 'C' Studs at 600mm centres. 50mm Isover Acoustic Roll in the cavity. Linings as in table.

▶ Refer to GypWall **ROBUST** and GypWall **EXTREME** sections for single layer Severe Duty solutions

Detail	Partition thickness mm	Board type	Lining thickness mm	Max height <sup>1</sup> mm	Sound insulation $R_w$ dB		Duty rating	Approx. weight kg/m <sup>2</sup>	System reference	
					Any <sup>2</sup> finish	Skim <sup>3</sup> only			Any <sup>2</sup> finish	Skim <sup>3</sup> only
<b>30 minutes fire resistance</b>										
①	97	Gyproc WallBoard	1 x 12.5	3600	36	-	Medium	18	A206013	-
①	97	Glasroc H TILEBACKER	1 x 12.5	3600	36	-	Medium	22	H206013	-
①	97	Gyproc SoundBloc	1 x 12.5	3600	40	-	Medium	22	A206164	-
②	97	Gyproc WallBoard	1 x 12.5	3600	42	-	Medium	18	A206045	-
②	97	Glasroc H TILEBACKER	1 x 12.5	3600	42	-	Medium	22	H206045	-
③	97	Gyproc WallBoard	1 x 12.5	3600	43	-	Medium	19	A206138	-
③	97	Glasroc H TILEBACKER	1 x 12.5	3600	43	-	Medium	23	H206138	-
②	97	Gyproc SoundBloc	1 x 12.5	3600	45	-	Medium	22	A206196	-
③	97	Gyproc SoundBloc	1 x 12.5	3600	47	-	Medium	22	A206228	-
①	102	Gyproc WallBoard	1 x 15	3800	38	39	Medium	22	A206014	A206014S
①	102	Gyproc SoundBloc	1 x 15	3800	42	-	Heavy	26	A206165	-
②	102	Gyproc WallBoard	1 x 15	3800	43	44	Medium	22	A206046	A206046S
③	102	Gyproc WallBoard	1 x 15	3800	44	45	Medium	22	A206139	A206139S
②	102	Gyproc SoundBloc	1 x 15	3800	47	48	Heavy	26	A206197	A206197S
<b>60 minutes fire resistance</b>										
①	102	Gyproc FireLine	1 x 15	3800	37	-	Heavy	24	A206078	-
②	102	Gyproc FireLine	1 x 15	3800	43	44	Heavy	24	A206110	A206110S
③	102	Gyproc FireLine	1 x 15	3800	44	45	Heavy	24	A206141	A206141S

▶ For further assistance in choosing the right solution for your project, try our System Selector; an online tool that enables quick and easy filtering by performance criteria. It provides system specific information downloads including BIM (Revit) objects. Go to [gyproc.ie](http://gyproc.ie)

<sup>1</sup>Based on a limiting deflection of L/240 at 200 Pa. Greater heights can be achieved through the use of Gypframe 'I' Studs, or reduced stud centres.

<sup>2</sup>Sound insulation performance for partitions finished using jointing or plaster skim.

<sup>3</sup>Sound insulation performance for partitions finished with a 2mm skim finish of Gyproc Skimcoat, Carlite Finish or Carlite Ultra Finish plaster.

**NB** The fire resistance and sound insulation performances are for imperforate partitions, walls and ceilings incorporating boards with all joints taped and filled, or skimmed according to Gyproc's recommendations. The quoted performances are achieved only if Gyproc and Isover components are used throughout, and the Company's fixing recommendations are strictly observed. Any variation in the specifications should be checked with Gyproc.

## GypWall performance (continued)

### 70mm Gypframe AcouStuds - single layer board linings

For details of when to specify fire resistance using EN  
 ▶ Refer to C02. S01. P18



Table 3a — Solutions to satisfy the requirements of BS EN 1364-1: 1999

①	②	③	④
One layer of board each side of 70mm Gypframe 70 AS 50 AcouStuds at 600mm centres. Linings as in table.	One layer of board each side of 70mm Gypframe 70 AS 50 AcouStuds at 600mm centres. 25mm Isover Acoustic Roll in the cavity. Linings as in table.	One layer of board each side of 70mm Gypframe 70 AS 50 AcouStuds at 600mm centres. 50mm Isover Acoustic Roll in the cavity. Linings as in table.	One layer of board each side of 70mm Gypframe 70 AS 50 AcouStuds at 600mm centres. 3 x 25mm Isover Acoustic Roll in the cavity. Linings as in table.

▶ Refer to GypWall **ROBUST** and GypWall **EXTREME** sections for single layer Severe Duty solutions

Detail	Partition thickness mm	Board type	Lining thickness mm	Max height <sup>1</sup> mm	Sound insulation R <sub>w</sub> dB		Duty rating	Approx. weight kg/m <sup>2</sup>	System reference	
					Any <sup>2</sup> finish	Skim <sup>3</sup> only			Any <sup>2</sup> finish	Skim <sup>3</sup> only
<b>30 minutes fire resistance (EN)</b>										
①	97	Gyproc SoundBloc	1 x 12.5	3800	41	-	Medium	22	A206A164	-
③	97	Gyproc WallBoard	1 x 12.5	3800	44	-	Medium	19	A206A138	-
②	97	Gyproc SoundBloc	1 x 12.5	3800	48	-	Medium	22	A206A196	-
③	97	Gyproc SoundBloc	1 x 12.5	3800	49	50	Medium	23	A206A228	A206A228S
①	102	Gyproc WallBoard	1 x 15	4000	38	39	Medium	22	A206A014	A206A014S
④	102	Gyproc SoundBloc	1 x 15	4000	50	51	Heavy	26	A206A252	A206A252S
<b>60 minutes fire resistance (EN)</b>										
①	102	Gyproc FireLine	1 x 15	4000	39	40	Heavy	24	A206A078	A206A078S
②	102	Gyproc FireLine	1 x 15	4000	43	44	Heavy	24	A206A110	A206A110S
③	102	Gyproc FireLine	1 x 15	4000	44	45	Heavy	24	A206A141	A206A141S

▶ For further assistance in choosing the right solution for your project, try our System Selector; an online tool that enables quick and easy filtering by performance criteria. It provides system specific information downloads including BIM (Revit) objects. Go to [gyproc.ie](http://gyproc.ie)

<sup>1</sup>The maximum heights quoted are limited by the fire state field of application or by limiting deflection of L/240 at 200 Pa, whichever is the more onerous.

<sup>2</sup>Sound insulation performance for partitions finished using jointing or plaster skim.

<sup>3</sup>Sound insulation performance for partitions finished with a 2mm skim finish of Gyproc Skimcoat, Carlite Finish or Carlite Ultra Finish plaster.

**(NB)** The fire resistance and sound insulation performances are for imperforate partitions, walls and ceilings incorporating boards with all joints taped and filled, or skimmed according to Gyproc's recommendations. The quoted performances are achieved only if Gyproc and Isover components are used throughout, and the Company's fixing recommendations are strictly observed. Any variation in the specifications should be checked with Gyproc.

## GypWall performance (continued)

### 70mm Gypframe AcouStuds - single layer board linings

For details of when to specify fire resistance using BS  
 Refer to C02. S01. P18



Table 3b — Solutions to satisfy the requirements of BS 476: Part 22: 1987

①		②		③		④	
	One layer of board each side of 70mm Gypframe 70 AS 50 AcouStuds at 600mm centres. Linings as in table.		One layer of board each side of 70mm Gypframe 70 AS 50 AcouStuds at 600mm centres. 25mm Isover Acoustic Roll in the cavity. Linings as in table.		One layer of board each side of 70mm Gypframe 70 AS 50 AcouStuds at 600mm centres. 50mm Isover Acoustic Roll in the cavity. Linings as in table.		One layer of board each side of 70mm Gypframe 70 AS 50 AcouStuds at 600mm centres. 3 x 25mm Isover Acoustic Roll in the cavity. Linings as in table.

Refer to GypWall **ROBUST** and GypWall **EXTREME** sections for single layer Severe Duty solutions

Detail	Partition thickness mm	Board type	Lining thickness mm	Max height <sup>1</sup> mm	Sound insulation $R_w$ dB		Duty rating	Approx. weight kg/m <sup>2</sup>	System reference	
					Any <sup>2</sup> finish	Skim <sup>3</sup> only			Any <sup>2</sup> finish	Skim <sup>3</sup> only
<b>30 minutes fire resistance (BS)</b>										
①	97	Gyproc SoundBloc	1 x 12.5	3800	41	-	Medium	22	A206A164	-
③	97	Gyproc WallBoard	1 x 12.5	3800	44	-	Medium	19	A206A138	-
②	97	Gyproc SoundBloc	1 x 12.5	3800	48	-	Medium	22	A206A196	-
③	97	Gyproc SoundBloc	1 x 12.5	3800	49	50	Medium	23	A206A228	A206A228S
④	102	Gyproc SoundBloc	1 x 15	4000	50	51	Heavy	26	A206A252	A206A252S
<b>60 minutes fire resistance (BS)</b>										
①	102	Gyproc FireLine	1 x 15	4000	39	40	Heavy	24	A206A078	A206A078S
②	102	Gyproc FireLine	1 x 15	4000	43	44	Heavy	24	A206A110	A206A110S
③	102	Gyproc FireLine	1 x 15	4000	44	45	Heavy	24	A206A141	A206A141S

For further assistance in choosing the right solution for your project, try our System Selector; an online tool that enables quick and easy filtering by performance criteria. It provides system specific information downloads including BIM (Revit) objects. Go to [gyproc.ie](http://gyproc.ie)

<sup>1</sup> Based on a limiting deflection of L/240 at 200 Pa. Greater heights can be achieved through the use of Gypframe 'I' Studs, or reduced stud centres.

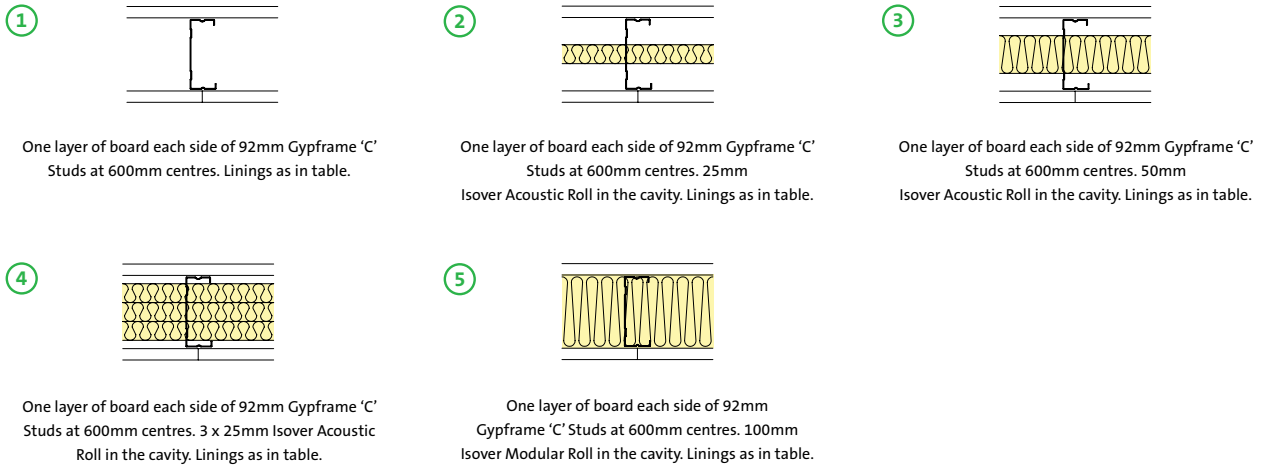
<sup>2</sup> Sound insulation performance for partitions finished using jointing or plaster skim.

<sup>3</sup> Sound insulation performance for partitions finished with a 2mm skim finish of Gyproc Skimcoat, Carlite Finish or Carlite Ultra Finish plaster.

**(NB)** The fire resistance and sound insulation performances are for imperforate partitions, walls and ceilings incorporating boards with all joints taped and filled, or skimmed according to Gyproc's recommendations. The quoted performances are achieved only if Gyproc and Isover components are used throughout, and the Company's fixing recommendations are strictly observed. Any variation in the specifications should be checked with Gyproc.



Table 4a — Solutions to satisfy the requirements of BS EN 1364-1: 1999



▶ Refer to GypWall ROBUST and GypWall EXTREME sections for single layer Severe Duty solutions

Detail	Partition thickness mm	Board type	Lining thickness mm	Max height <sup>1</sup> mm	Sound insulation $R_w$ dB		Duty rating	Approx. weight kg/m <sup>2</sup>	System reference	
					Any finish <sup>2</sup>	Skim only <sup>3</sup>			Any finish <sup>2</sup>	Skim only <sup>3</sup>
<b>30 minutes fire resistance (EN)</b>										
4	119	Gyproc SoundBloc	1 x 12.5	4000	50	51	Medium	23	A206232	A206232S
1	124	Gyproc SoundBloc	1 x 15	4000	44	45	Heavy	27	A206261	A206261S
2	124	Gyproc SoundBloc	1 x 15	4000	49	50	Heavy	27	A206262	A206262S
3	124	Gyproc SoundBloc	1 x 15	4000	50	51	Heavy	27	A206263	A206263S
5	124	Gyproc SoundBloc	1 x 15	4000	51	52	Heavy	27	A206264	A206264S
4	124	Gyproc SoundBloc	1 x 15	4000	52	53	Heavy	27	A206233	A206233S
<b>60 minutes fire resistance (EN)</b>										
1	124	Gyproc FireLine	1 x 15	4000	40	41	Heavy	25	A206265	A206265S
2	124	Gyproc FireLine	1 x 15	4000	44 <sup>4</sup>	45 <sup>4</sup>	Heavy	25	A206266	A206266S
5	124	Gyproc FireLine	1 x 15	4000	46	48	Heavy	25	A206268	A206268S

▶ For further assistance in choosing the right solution for your project, try our System Selector; an online tool that enables quick and easy filtering by performance criteria. It provides system specific information downloads including BIM (Revit) objects. Go to [gyproc.ie](http://gyproc.ie)

<sup>1</sup>The maximum heights quoted are limited by the fire state field of application or by limiting deflection of L/240 at 200 Pa, whichever is the more onerous.

<sup>2</sup>Sound insulation performance for partitions finished using jointing or plaster skim.

<sup>3</sup>Sound insulation performance for partitions finished with a 2mm skim finish of Gyproc Skimcoat, Carlite Finish or Carlite Ultra Finish plaster.

<sup>4</sup>Increasing the insulation to 50mm Isover Acoustic Roll will not improve the system performance.

**(NB)** The fire resistance and sound insulation performances are for imperforate partitions, walls and ceilings incorporating boards with all joints taped and filled, or skimmed according to Gyproc's recommendations. The quoted performances are achieved only if Gyproc and Isover components are used throughout, and the Company's fixing recommendations are strictly observed. Any variation in the specifications should be checked with Gyproc.

# GypWall performance (continued)

## 92mm Gypframe 'C' Studs - single layer board linings

For details of when to specify fire resistance using BS  
 ▶ Refer to C02. S01. P18



Table 4b — Solutions to satisfy the requirements of BS 476: Part 22: 1987

①		②		③	
	One layer of board each side of 92mm Gypframe 'C' Studs at 600mm centres. Linings as in table.		One layer of board each side of 92mm Gypframe 'C' Studs at 600mm centres. 25mm Isover Acoustic Roll in the cavity. Linings as in table.		One layer of board each side of 92mm Gypframe 'C' Studs at 600mm centres. 50mm Isover Acoustic Roll in the cavity. Linings as in table.
④		⑤			
	One layer of board each side of 92mm Gypframe 'C' Studs at 600mm centres. 3 x 25mm Isover Acoustic Roll in the cavity. Linings as in table.		One layer of board each side of 92mm Gypframe 'C' Studs at 600mm centres. 100mm Isover Modular Roll in the cavity. Linings as in table.		

▶ Refer to GypWall **ROBUST** and GypWall **EXTREME** sections for single layer Severe Duty solutions

Detail	Partition thickness mm	Board type	Lining thickness mm	Max height <sup>1</sup> mm	Sound insulation $R_w$ dB		Duty rating	Approx. weight kg/m <sup>2</sup>	System reference	
					Any finish <sup>2</sup>	Skim only <sup>3</sup>			Any finish <sup>2</sup>	Skim only <sup>3</sup>
<b>30 minutes fire resistance</b> (BS)										
④	119	Gyproc SoundBloc	1 x 12.5	4500	50	51	Medium	23	A206232	A206232S
①	124	Gyproc SoundBloc	1 x 15	4700	44	45	Heavy	27	A206261	A206261S
②	124	Gyproc SoundBloc	1 x 15	4700	49	50	Heavy	27	A206262	A206262S
③	124	Gyproc SoundBloc	1 x 15	4700	50	51	Heavy	27	A206263	A206263S
⑤	124	Gyproc SoundBloc	1 x 15	4700	51	52	Heavy	27	A206264	A206264S
④	124	Gyproc SoundBloc	1 x 15	4700	52	53	Heavy	27	A206233	A206233S
<b>60 minutes fire resistance</b> (BS)										
①	124	Gyproc FireLine	1 x 15	4700	40	41	Heavy	25	A206265	A206265S
②	124	Gyproc FireLine	1 x 15	4700	44 <sup>4</sup>	45 <sup>4</sup>	Heavy	25	A206266	A206266S
⑤	124	Gyproc FireLine	1 x 15	4700	46	48	Heavy	25	A206268	A206268S

▶ For further assistance in choosing the right solution for your project, try our System Selector; an online tool that enables quick and easy filtering by performance criteria. It provides system specific information downloads including BIM (Revit) objects. Go to [gyproc.ie](http://gyproc.ie)

<sup>1</sup> Based on a limiting deflection of L/240 at 200 Pa. Greater heights can be achieved through the use of Gypframe 'I' Studs, or reduced stud centres.

<sup>2</sup> Sound insulation performance for partitions finished using jointing or plaster skim.

<sup>3</sup> Sound insulation performance for partitions finished with a 2mm skim finish of Gyproc Skimcoat, Carlite Finish or Carlite Ultra Finish plaster.

<sup>4</sup> Increasing insulation to 50mm Isover Acoustic Roll will not improve this system performance.

**(NB)** The fire resistance and sound insulation performances are for imperforate partitions, walls and ceilings incorporating boards with all joints taped and filled, or skimmed according to Gyproc's recommendations. The quoted performances are achieved only if Gyproc and Isover components are used throughout, and the Company's fixing recommendations are strictly observed. Any variation in the specifications should be checked with Gyproc.

**(NB)** For heights between 4200mm and 8000mm, Gypframe Deep Flange Floor & Ceiling Channel should be used at base and at head (subject to deflection criteria).

## GypWall performance (continued)

### 92mm Gypframe AcouStuds - single layer board linings

For details of when to specify fire resistance using EN  
 ► Refer to C02. S01. P18



Table 5a — Solutions to satisfy the requirements of BS EN 1364-1: 1999

①	②	③	④
One layer of board each side of 92mm Gypframe AcouStuds at 600mm centres. Linings as in table.	One layer of board each side of 92mm Gypframe AcouStuds at 600mm centres. 25mm Isover Acoustic Roll in the cavity. Linings as in table.	One layer of board each side of 92mm Gypframe AcouStuds at 600mm centres. 50mm Isover Acoustic Roll in the cavity. Linings as in table.	One layer of board each side of 92mm Gypframe AcouStuds at 600mm centres. 100mm Isover Modular Roll in the cavity. Linings as in table.

► Refer to GypWall **ROBUST** and GypWall **EXTREME** sections for single layer Severe Duty solutions

Detail	Partition thickness mm	Board type	Lining thickness mm	Max height <sup>1</sup> mm	Sound insulation $R_w$ dB		Duty rating	Approx. weight kg/m <sup>2</sup>	System reference	
					Any <sup>2</sup> finish	Skim <sup>3</sup> only			Any <sup>2</sup> finish	Skim <sup>3</sup> only
<b>30 minutes fire resistance</b> (EN)										
①	124	Gyproc SoundBloc	1 x 15	4000	45	46	Heavy	27	A206A281	A206A281S
②	124	Gyproc SoundBloc	1 x 15	4000	50	51	Heavy	27	A206A282	A206A282S
③	124	Gyproc SoundBloc	1 x 15	4000	51	52	Heavy	27	A206A283	A206A283S
④	124	Gyproc SoundBloc	1 x 15	4000	52	54	Heavy	27	A206A284	A206A284S
<b>60 minutes fire resistance</b> (EN)										
①	124	Gyproc FireLine	1 x 15	4000	41	42	Heavy	24	A206A285	A206A285S
②	124	Gyproc FireLine	1 x 15	4000	44 <sup>4</sup>	45 <sup>4</sup>	Heavy	24	A206A286	A206A286S
④	124	Gyproc FireLine	1 x 15	4000	46	48	Heavy	24	A206A288	A206A288S

► For further assistance in choosing the right solution for your project, try our System Selector; an online tool that enables quick and easy filtering by performance criteria. It provides system specific information downloads including BIM (Revit) objects. Go to [gyproc.ie](http://gyproc.ie)

<sup>1</sup> The maximum heights quoted are limited by the fire state field of application or by limiting deflection of L/240 at 200 Pa, whichever is the more onerous.

<sup>2</sup> Sound insulation performance for partitions finished using jointing or plaster skim.

<sup>3</sup> Sound insulation performance for partitions finished with a 2mm skim finish of Gyproc Skimcoat, Carlite Finish or Carlite Ultra Finish plaster.

<sup>4</sup> Increasing insulation to 50mm Isover Acoustic Roll will not improve this system performance.

**(NB)** The fire resistance and sound insulation performances are for imperforate partitions, walls and ceilings incorporating boards with all joints taped and filled, or skimmed according to Gyproc's recommendations. The quoted performances are achieved only if Gyproc and Isover components are used throughout, and the Company's fixing recommendations are strictly observed. Any variation in the specifications should be checked with Gyproc.

## GypWall performance (continued)

### 92mm Gypframe AcouStuds - single layer board linings

For details of when to specify fire resistance using BS  
 ▶ Refer to C02. S01. P18



Table 5b — Solutions to satisfy the requirements of BS 476: Part 22: 1987

①		②		③		④	
	One layer of board each side of 92mm Gypframe AcouStuds at 600mm centres. Linings as in table.		One layer of board each side of 92mm Gypframe AcouStuds at 600mm centres. 25mm Isover Acoustic Roll in the cavity. Linings as in table.		One layer of board each side of 92mm Gypframe AcouStuds at 600mm centres. 50mm Isover Acoustic Roll in the cavity. Linings as in table.		One layer of board each side of 92mm Gypframe AcouStuds at 600mm centres. 100mm Isover Modular Roll in the cavity. Linings as in table.

▶ Refer to GypWall **ROBUST** and GypWall **EXTREME** sections for single layer Severe Duty solutions

Detail	Partition thickness mm	Board type	Lining thickness mm	Max height <sup>1</sup> mm	Sound insulation $R_w$ dB		Duty rating	Approx. weight kg/m <sup>2</sup>	System reference	
					Any <sup>2</sup> finish	Skim <sup>3</sup> only			Any <sup>2</sup> finish	Skim <sup>3</sup> only
<b>30 minutes fire resistance</b> (BS)										
①	124	Gyproc SoundBloc	1 x 15	4900	45	46	Heavy	27	A206A281	A206A281S
②	124	Gyproc SoundBloc	1 x 15	4900	50	51	Heavy	27	A206A282	A206A282S
③	124	Gyproc SoundBloc	1 x 15	4900	51	52	Heavy	27	A206A283	A206A283S
④	124	Gyproc SoundBloc	1 x 15	4900	52	54	Heavy	27	A206A284	A206A284S
<b>60 minutes fire resistance</b> (BS)										
①	124	Gyproc FireLine	1 x 15	4900	41	42	Heavy	24	A206A285	A206A285S
②	124	Gyproc FireLine	1 x 15	4900	44 <sup>4</sup>	45 <sup>4</sup>	Heavy	24	A206A286	A206A286S
④	124	Gyproc FireLine	1 x 15	4900	46	48	Heavy	24	A206A288	A206A288S

▶ For further assistance in choosing the right solution for your project, try our System Selector; an online tool that enables quick and easy filtering by performance criteria. It provides system specific information downloads including BIM (Revit) objects. Go to [gyproc.ie](http://gyproc.ie)

<sup>1</sup> Based on a limiting deflection of L/240 at 200 Pa. Greater heights can be achieved through the use of Gypframe 'I' Studs, or reduced stud centres.

<sup>2</sup> Sound insulation performance for partitions finished using jointing or plaster skim.

<sup>3</sup> Sound insulation performance for partitions finished with a 2mm skim finish of Gyproc Skimcoat, Carlite Finish or Carlite Ultra Finish plaster.

<sup>4</sup> Increasing insulation to 50mm Isover Acoustic Roll will not improve this system performance.

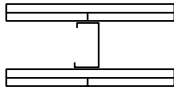
**(NB)** The fire resistance and sound insulation performances are for imperforate partitions, walls and ceilings incorporating boards with all joints taped and filled, or skimmed according to Gyproc's recommendations. The quoted performances are achieved only if Gyproc and Isover components are used throughout, and the Company's fixing recommendations are strictly observed. Any variation in the specifications should be checked with Gyproc.

**(NB)** For heights between 4200mm and 8000mm, Gypframe Deep Flange Floor & Ceiling Channel should be used at base and at head (subject to deflection criteria).



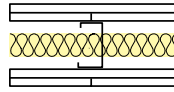
Table 6a — Solutions to satisfy the requirements of BS EN 1364-1: 1999

①



Two layers of board each side of 48mm Gypframe 'C' Studs at 600mm centres. Linings as in table.

②



Two layers of board each side of 48mm Gypframe 'C' Studs at 600mm centres. 25mm Isover Acoustic Roll in the cavity. Linings as in table.

▶ Refer to GypWall ROBUST and GypWall EXTREME sections for single layer Severe Duty solutions

Detail	Partition thickness mm	Board type	Lining thickness mm	Max height <sup>1</sup> mm	Sound insulation R <sub>w</sub> dB		Duty rating	Approx. weight kg/m <sup>2</sup>	System reference	
					Any <sup>2</sup> finish	Skim <sup>3</sup> only			Any <sup>2</sup> finish	Skim <sup>3</sup> only
<b>30 minutes fire resistance</b> (EN)										
①	100	Gyproc WallBoard	2 x 12.5	3400	42	-	Severe	35	A206003	-
①	100	Outer layer Glasroc H TILEBACKER + inner layer Gyproc WallBoard	1 x 12.5 + 1 x 12.5	3400	42	-	Severe	39	H206003	-
②	100	Gyproc WallBoard	2 x 12.5	3000	49	-	Severe	35	A206035	-
②	100	Outer layer Glasroc H TILEBACKER + inner layer Gyproc WallBoard	1 x 12.5 + 1 x 12.5	3000	49	-	Severe	39	H206035	-
<b>60 minutes fire resistance</b> (EN)										
①	100	Gyproc SoundBloc	2 x 12.5	3000	46	-	Severe	43	A206154	-
②	100	Gyproc SoundBloc	2 x 12.5	3000	51	-	Severe	43	A206186	-
①	110	Gyproc WallBoard	2 x 15	3700	45	-	Severe	42	A206004	-
<b>90 minutes fire resistance</b> (EN)										
①	110	Gyproc SoundBloc	2 x 15	3000	49	-	Severe	51	A206155	-
②	110	Gyproc SoundBloc	2 x 15	3000	53	54	Severe	51	A206187	A206187S
<b>120 minutes fire resistance</b> (EN)										
①	100	Gyproc FireLine	2 x 12.5	3400	42	-	Severe	40	A206067	-
②	100	Gyproc FireLine	2 x 12.5	3400	49	-	Severe	40	A206099	-
①	110	Gyproc FireLine	2 x 15	3700	45	-	Severe	49	A206156	-

▶ For further assistance in choosing the right solution for your project, try our System Selector; an online tool that enables quick and easy filtering by performance criteria. It provides system specific information downloads including BIM (Revit) objects. Go to [gyproc.ie](http://gyproc.ie)

<sup>1</sup>The maximum heights quoted are limited by the fire state field of application or by limiting deflection of L/240 at 200 Pa, whichever is the more onerous.

<sup>2</sup>Sound insulation performance for partitions finished using jointing or plaster skim.

<sup>3</sup>Sound insulation performance for partitions finished with a 2mm skim finish of Gyproc Skimcoat, Carlite Finish or Carlite Ultra Finish plaster.

**(NB)** The fire resistance and sound insulation performances are for imperforate partitions, walls and ceilings incorporating boards with all joints taped and filled, or skimmed according to Gyproc's recommendations. The quoted performances are achieved only if Gyproc and Isover components are used throughout, and the Company's fixing recommendations are strictly observed. Any variation in the specifications should be checked with Gyproc.

## GypWall performance (continued)

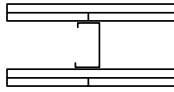
### 48mm Gypframe 'C' Studs - double layer board linings

For details of when to specify fire resistance using BS  
 ▶ Refer to C02. S01. P18



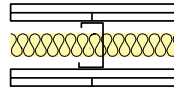
Table 6b — Solutions to satisfy the requirements of BS 476: Part 22: 1987

①



Two layers of board each side of 48mm Gypframe 'C' Studs at 600mm centres. Linings as in table.

②



Two layers of board each side of 48mm Gypframe 'C' Studs at 600mm centres. 25mm Isover Acoustic Roll in the cavity. Linings as in table.

▶ Refer to GypWall **ROBUST** and GypWall **EXTREME** sections for single layer Severe Duty solutions

Detail	Partition thickness mm	Board type	Lining thickness mm	Max height <sup>1</sup> mm	Sound insulation $R_w$ dB		Duty rating	Approx. weight kg/m <sup>2</sup>	System reference	
					Any <sup>2</sup> finish	Skim <sup>3</sup> only			Any <sup>2</sup> finish	Skim <sup>3</sup> only
<b>60 minutes fire resistance (BS)</b>										
①	100	Gyproc WallBoard	2 x 12.5	3400	42	-	Severe	35	A206003	-
①	100	Outer layer Glasroc H TILEBACKER + inner layer Gyproc WallBoard	1 x 12.5 + 1 x 12.5	3400	42	-	Severe	39	H206003	-
①	100	Gyproc SoundBloc	2 x 12.5	3400	46	-	Severe	43	A206154	-
②	100	Gyproc WallBoard	2 x 12.5	3400	49	-	Severe	35	A206035	-
②	100	Outer layer Glasroc H TILEBACKER + inner layer Gyproc WallBoard	1 x 12.5 + 1 x 12.5	3400	49	-	Severe	39	H206035	-
②	100	Gyproc SoundBloc	2 x 12.5	3400	51	-	Severe	43	A206186	-
<b>90 minutes fire resistance (BS)</b>										
①	110	Gyproc WallBoard	2 x 15	3700	45	-	Severe	42	A206004	-
①	110	Gyproc SoundBloc	2 x 15	3700	49	-	Severe	51	A206155	-
②	110	Gyproc WallBoard	2 x 15	3700	49	-	Severe	42	A206036	-
②	110	Gyproc SoundBloc	2 x 15	3700	53	54	Severe	51	A206187	A206187S
<b>120 minutes fire resistance (BS)</b>										
①	100	Gyproc FireLine	2 x 12.5	3400	42	-	Severe	40	A206067	-
②	100	Gyproc FireLine	2 x 12.5	3400	49	-	Severe	40	A206099	-

▶ For further assistance in choosing the right solution for your project, try our System Selector; an online tool that enables quick and easy filtering by performance criteria. It provides system specific information downloads including BIM (Revit) objects. Go to [gyproc.ie](http://gyproc.ie)

<sup>1</sup> Based on a limiting deflection of L/240 at 200 Pa. Greater heights can be achieved through the use of Gypframe 'I' Studs, or reduced stud centres.

<sup>2</sup> Sound insulation performance for partitions finished using jointing or plaster skim.

<sup>3</sup> Sound insulation performance for partitions finished with a 2mm skim finish of Gyproc Skimcoat, Carlite Finish or Carlite Ultra Finish plaster.

**(NB)** The fire resistance and sound insulation performances are for imperforate partitions, walls and ceilings incorporating boards with all joints taped and filled, or skimmed according to Gyproc's recommendations. The quoted performances are achieved only if Gyproc and Isover components are used throughout, and the Company's fixing recommendations are strictly observed. Any variation in the specifications should be checked with Gyproc.

## GypWall performance (continued)

### 70mm Gypframe 'C' Studs - double layer board linings

For details of when to specify fire resistance using EN  
 ▶ Refer to C02. S01. P18



Table 7a — Solutions to satisfy the requirements of BS EN 1364-1: 1999

①		②		③	
	Two layers of board each side of 70mm Gypframe 'C' Studs at 600mm centres. Linings as in table.		Two layers of board each side of 70mm Gypframe 'C' Studs at 600mm centres. 25mm Isover Acoustic Roll in the cavity. Linings as in table.		Two layers of board each side of 70mm Gypframe 'C' Studs at 600mm centres. 50mm Isover Acoustic Roll in the cavity. Linings as in table.

▶ Refer to GypWall **ROBUST** and GypWall **EXTREME** sections for single layer Severe Duty solutions

Detail	Partition thickness mm	Board type	Lining thickness mm	Max height <sup>1</sup> mm	Sound insulation $R_w$ dB		Duty rating	Approx. weight kg/m <sup>2</sup>	System reference	
					Any <sup>2</sup> finish	Skim <sup>3</sup> only			Any <sup>2</sup> finish	Skim <sup>3</sup> only
<b>30 minutes fire resistance</b> (EN)										
①	122	Gyproc WallBoard	2 x 12.5	4600	45	-	Severe	35	A206015	-
①	122	Outer layer Glasroc H TILEBACKER + inner layer Gyproc WallBoard	1 x 12.5 + 1 x 12.5	4600	45	-	Severe	39	H206015	-
②	122	Gyproc WallBoard	2 x 12.5	4600	49	-	Severe	35	A206047	-
<b>60 minutes fire resistance</b> (EN)										
①	122	Gyproc SoundBloc	2 x 12.5	4600	49	-	Severe	43	A206166	-
③	122	Gyproc WallBoard	2 x 12.5	4000	50	-	Severe	35	A206142	-
③	122	Outer layer Glasroc H TILEBACKER + inner layer Gyproc WallBoard	1 x 12.5 + 1 x 12.5	4000	50	-	Severe	39	H206142	-
②	122	Gyproc SoundBloc	2 x 12.5	4000	52	-	Severe	43	A206198	-
③	122	Gyproc SoundBloc	2 x 12.5	4000	53	-	Severe	44	A206230	-
①	132	Gyproc WallBoard	2 x 15	4900	46	47	Severe	42	A206016	A206016S
②	132	Gyproc WallBoard	2 x 15	4000	50	-	Severe	42	A206048	-
<b>90 minutes fire resistance</b> (EN)										
①	132	Gyproc SoundBloc	2 x 15	4000	51	52	Severe	51	A206167	A206167S
②	132	Gyproc SoundBloc	2 x 15	4000	54	55	Severe	51	A206199	A206199S
③	132	Gyproc SoundBloc	2 x 15	4000	56	57	Severe	52	A206231	A206231S
<b>120 minutes fire resistance</b> (EN)										
①	122	Gyproc FireLine	2 x 12.5	4200	46	-	Severe	40	A206079	-
②	122	Gyproc FireLine	2 x 12.5	4000	49	-	Severe	40	A206111	-
③	122	Gyproc FireLine	2 x 12.5	4000	50	-	Severe	40	A206144	-
①	132	Gyproc FireLine	2 x 15	4900	46	47	Severe	47	A206251	A206251S
②	132	Gyproc FireLine	2 x 15	4300	50	-	Severe	49	A206253	-

▶ For further assistance in choosing the right solution for your project, try our System Selector; an online tool that enables quick and easy filtering by performance criteria. It provides system specific information downloads including BIM (Revit) objects. Go to [gyproc.ie](http://gyproc.ie)

<sup>1</sup> The maximum heights quoted are limited by the fire state field of application or by limiting deflection of L/240 at 200 Pa, whichever is the more onerous.

<sup>2</sup> Sound insulation performance for partitions finished using jointing or plaster skim.

<sup>3</sup> Sound insulation performance for partitions finished with a 2mm skim finish of Gyproc Skimcoat, Carlite Finish or Carlite Ultra Finish plaster.

**(NB)** The fire resistance and sound insulation performances are for imperforate partitions, walls and ceilings incorporating boards with all joints taped and filled, or skimmed according to Gyproc's recommendations. The quoted performances are achieved only if Gyproc and Isover components are used throughout, and the Company's fixing recommendations are strictly observed. Any variation in the specifications should be checked with Gyproc.

**(NB)** For heights between 4200mm and 8000mm, Gypframe Deep Flange Floor & Ceiling Channel should be used at base and at head (subject to deflection criteria).

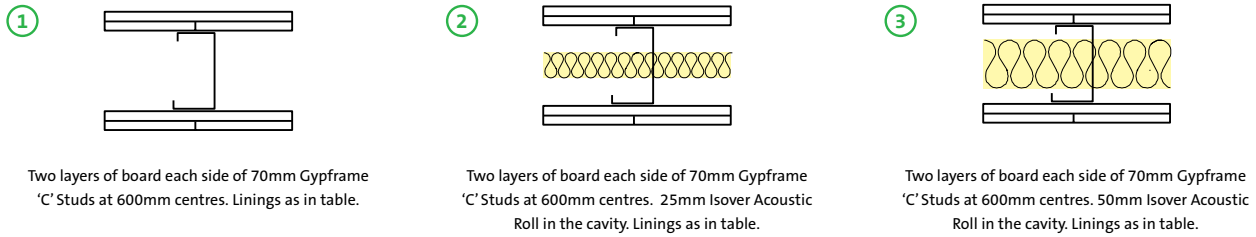
## GypWall performance (continued)

### 70mm Gypframe 'C' Studs - double layer board linings

For details of when to specify fire resistance using BS  
 ▶ Refer to C02. S01. P18



Table 7b — Solutions to satisfy the requirements of BS 476: Part 22: 1987



▶ Refer to GypWall **ROBUST** and GypWall **EXTREME** sections for single layer Severe Duty solutions

Detail	Partition thickness mm	Board type	Lining thickness mm	Max height <sup>1</sup> mm	Sound insulation $R_w$ dB		Duty rating	Approx. weight kg/m <sup>2</sup>	System reference	
					Any <sup>2</sup> finish	Skim <sup>3</sup> only			Any <sup>2</sup> finish	Skim <sup>3</sup> only
<b>60 minutes fire resistance</b> <span style="border: 1px solid black; border-radius: 50%; padding: 2px;">BS</span>										
①	122	Gyproc WallBoard	2 x 12.5	4600	45	-	Severe	35	A206015	-
①	122	Outer layer Glasroc H <small>TILEBACKER</small> + inner layer Gyproc WallBoard	1 x 12.5 + 1 x 12.5	4600	45	-	Severe	39	H206015	-
①	122	Gyproc SoundBloc	2 x 12.5	4600	49	-	Severe	43	A206166	-
②	122	Gyproc WallBoard	2 x 12.5	4600	49	-	Severe	35	A206047	-
②	122	Outer layer Glasroc H <small>TILEBACKER</small> + inner layer Gyproc WallBoard	1 x 12.5 + 1 x 12.5	4600	49	-	Severe	39	H206047	-
③	122	Gyproc WallBoard	2 x 12.5	4600	50	-	Severe	36	A206142	-
③	122	Outer layer Glasroc H <small>TILEBACKER</small> + inner layer Gyproc WallBoard	1 x 12.5 + 1 x 12.5	4600	50	-	Severe	39	H206142	-
②	122	Gyproc SoundBloc	2 x 12.5	4600	52	-	Severe	43	A206198	-
③	122	Gyproc SoundBloc	2 x 12.5	4600	53	-	Severe	44	A206230	-
<b>90 minutes fire resistance</b> <span style="border: 1px solid black; border-radius: 50%; padding: 2px;">BS</span>										
①	132	Gyproc WallBoard	2 x 15	4900	46	47	Severe	42	A206016	A206016S
②	132	Gyproc WallBoard	2 x 15	4900	50	-	Severe	42	A206048	-
①	132	Gyproc SoundBloc	2 x 15	4900	51	52	Severe	51	A206167	A206167S
②	132	Gyproc SoundBloc	2 x 15	4900	54	55	Severe	51	A206199	-
③	132	Gyproc SoundBloc	2 x 15	4900	56	57	Severe	52	A206231	A206231S
<b>120 minutes fire resistance</b> <span style="border: 1px solid black; border-radius: 50%; padding: 2px;">BS</span>										
①	112	Glasroc F <small>MULTIBOARD</small>	2 x 10	4200	42	--	Severe	40	G106013	-
①	122	Gyproc FireLine	2 x 12.5	4600	46	-	Severe	40	A206079	-
②	122	Gyproc FireLine	2 x 12.5	4600	49	-	Severe	40	A206111	-
③	122	Gyproc FireLine	2 x 12.5	4600	50	-	Severe	41	A206144	-

▶ For further assistance in choosing the right solution for your project, try our System Selector; an online tool that enables quick and easy filtering by performance criteria. It provides system specific information downloads including BIM (Revit) objects. Go to [gyproc.ie](http://gyproc.ie)

<sup>1</sup> Based on a limiting deflection of L/240 at 200 Pa. Greater heights can be achieved through the use of Gypframe 'I' Studs, or reduced stud centres.

<sup>2</sup> Sound insulation performance for partitions finished using jointing or plaster skim.

<sup>3</sup> Sound insulation performance for partitions finished with a 2mm skim finish of Gyproc Skimcoat, Carlite Finish or Carlite Ultra Finish plaster.

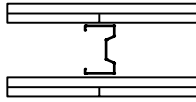
**NB** The fire resistance and sound insulation performances are for imperforate partitions, walls and ceilings incorporating boards with all joints taped and filled, or skimmed according to Gyproc's recommendations. The quoted performances are achieved only if Gyproc and Isover components are used throughout, and the Company's fixing recommendations are strictly observed. Any variation in the specifications should be checked with Gyproc.

**NB** For heights between 4200mm and 8000mm, Gypframe Deep Flange Floor & Ceiling Channel should be used at base and at head (subject to deflection criteria).



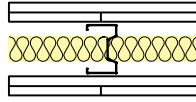
Table 8a – Solutions to satisfy the requirements of BS EN 1364-1: 1999

①



Two layers of board each side of 70mm Gypframe 70 AS 50 AcouStuds at 600mm centres. Linings as in table.

②



Two layers of board each side of 70mm Gypframe 70 AS 50 AcouStuds at 600mm centres. 25mm Isovex Acoustic Roll in the cavity. Linings as in table.

▶ Refer to GypWall ROBUST and GypWall EXTREME sections for single layer Severe Duty solutions

Detail	Partition thickness mm	Board type	Lining thickness mm	Max height <sup>1</sup> mm	Sound insulation R <sub>w</sub> dB		Duty rating	Approx. weight kg/m <sup>2</sup>	System reference	
					Any <sup>2</sup> finish	Skim <sup>3</sup> only			Any <sup>2</sup> finish	Skim <sup>3</sup> only
<b>30 minutes fire resistance</b> (EN)										
①	122	Gyproc WallBoard	2 x 12.5	4700	47	-	Severe	35	A206A015	-
<b>60 minutes fire resistance</b> (EN)										
①	122	Gyproc SoundBloc	2 x 12.5	4700	53	-	Severe	43	A206A166	-
②	122	Gyproc SoundBloc	2 x 12.5	4000	58	59	Severe	43	A206A198	A206A198S
<b>90 minutes fire resistance</b> (EN)										
①	122	Gyproc FireLine	2 x 12.5	4700	49	50	Severe	40	A206A079	A206A079S
②	122	Gyproc FireLine	2 x 12.5	4700	54	55	Severe	40	A206A111	A206A111S
①	132	Gyproc SoundBloc	2 x 15	4000	54	55	Severe	51	A206A167	A206A167S
<b>120 minutes fire resistance</b> (EN)										
①	122	Gyproc FireLine	2 x 12.5	4200	49	50	Severe	40	A206A079	A206A079S
②	122	Gyproc FireLine	2 x 12.5	4000	54	55	Severe	40	A206A111	A206A111S
①	132	Gyproc FireLine	2 x 15	5000	49	50	Severe	49	A206A251	A206A251S

▶ For further assistance in choosing the right solution for your project, try our System Selector; an online tool that enables quick and easy filtering by performance criteria. It provides system specific information downloads including BIM (Revit) objects. Go to [gyproc.ie](http://gyproc.ie)

<sup>1</sup>The maximum heights quoted are limited by the fire state field of application or by limiting deflection of L/240 at 200 Pa, whichever is the more onerous.

<sup>2</sup>Sound insulation performance for partitions finished using jointing or plaster skim.

<sup>3</sup>Sound insulation performance for partitions finished with a 2mm skim finish of Gyproc Skimcoat, Carlite Finish or Carlite Ultra Finish plaster.

**(NB)** The fire resistance and sound insulation performances are for imperforate partitions, walls and ceilings incorporating boards with all joints taped and filled, or skimmed according to Gyproc's recommendations. The quoted performances are achieved only if Gyproc and Isovex components are used throughout, and the Company's fixing recommendations are strictly observed. Any variation in the specifications should be checked with Gyproc.

**(NB)** For heights between 4200mm and 8000mm, Gypframe Deep Flange Floor & Ceiling Channel should be used at base and at head (subject to deflection criteria).

## GypWall performance (continued)

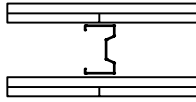
### 70mm Gypframe AcouStuds - double layer board linings

For details of when to specify fire resistance using BS  
 ▶ Refer to C02. S01. P18



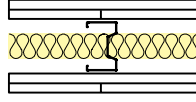
Table 8b — Solutions to satisfy the requirements of BS 476: Part 22: 1987

①



Two layers of board each side of 70mm Gypframe 70 AS 50 AcouStuds at 600mm centres. Linings as in table.

②



Two layers of board each side of 70mm Gypframe 70 AS 50 AcouStuds at 600mm centres. 25mm Isover Acoustic Roll in the cavity. Linings as in table.

▶ Refer to GypWall **ROBUST** and GypWall **EXTREME** sections for single layer Severe Duty solutions

Detail	Partition thickness mm	Board type	Lining thickness mm	Max height <sup>1</sup> mm	Sound insulation $R_w$ dB		Duty rating	Approx. weight kg/m <sup>2</sup>	System reference	
					Any <sup>2</sup> finish	Skim <sup>3</sup> only			Any <sup>2</sup> finish	Skim <sup>3</sup> only
<b>60 minutes fire resistance</b> (BS)										
①	122	Gyproc WallBoard	2 x 12.5	4700	47	-	Severe	35	A206A015	-
①	122	Gyproc SoundBloc	2 x 12.5	4700	53	-	Severe	43	A206A166	-
②	122	Gyproc SoundBloc	2 x 12.5	4700	58	59	Severe	43	A206A198	A206A198S
<b>90 minutes fire resistance</b> (BS)										
①	132	Gyproc SoundBloc	2 x 15	5000	54	55	Severe	51	A206A167	A206A167S
<b>120 minutes fire resistance</b> (BS)										
①	122	Gyproc FireLine	2 x 12.5	4700	49	50	Severe	40	A206A079	A206A079S
②	122	Gyproc FireLine	2 x 12.5	4700	54	55	Severe	40	A206A111	A206A111S

▶ For further assistance in choosing the right solution for your project, try our System Selector; an online tool that enables quick and easy filtering by performance criteria. It provides system specific information downloads including BIM (Revit) objects. Go to [gyproc.ie](http://gyproc.ie)

<sup>1</sup> Based on a limiting deflection of L/240 at 200 Pa. Greater heights can be achieved through the use of Gypframe 'I' Studs, or reduced stud centres.

<sup>2</sup> Sound insulation performance for partitions finished using jointing or plaster skim.

<sup>3</sup> Sound insulation performance for partitions finished with a 2mm skim finish of Gyproc Skimcoat, Carlite Finish or Carlite Ultra Finish plaster.

**(NB)** The fire resistance and sound insulation performances are for imperforate partitions, walls and ceilings incorporating boards with all joints taped and filled, or skimmed according to Gyproc's recommendations. The quoted performances are achieved only if Gyproc and Isover components are used throughout, and the Company's fixing recommendations are strictly observed. Any variation in the specifications should be checked with Gyproc.

**(NB)** For heights between 4200mm and 8000mm, Gypframe Deep Flange Floor & Ceiling Channel should be used at base and at head (subject to deflection criteria).

## GypWall performance (continued)

### 92mm Gypframe 'C' Studs - double layer board linings

For details of when to specify fire resistance using EN  
 ▶ Refer to C02. S01. P18



Table 9a — Solutions to satisfy the requirements of BS EN 1364-1: 1999

①	②	③	④
Two layers of board each side of 92mm Gypframe 'C' Studs at 600mm centres. Linings as in table.	Two layers of board each side of 92mm Gypframe 'C' Studs at 600mm centres. 25mm Isover Acoustic Roll in the cavity. Linings as in table.	Two layers of board each side of 92mm Gypframe 'C' Studs at 600mm centres. 3 x 25mm Isover Acoustic Roll in the cavity. Linings as in table.	Two layers of board each side of 92mm Gypframe 'C' Studs at 600mm centres. 100mm Isover Modular Roll in the cavity. Linings as in table.

▶ Refer to GypWall **ROBUST** and GypWall **EXTREME** sections for single layer Severe Duty solutions

Detail	Partition thickness mm	Board type	Lining thickness mm	Max height <sup>1</sup> mm	Sound insulation $R_w (R_w + C_v)$ dB		Duty rating	Approx. weight kg/m <sup>2</sup>	System reference	
					Any <sup>2</sup> finish	Skim <sup>3</sup> only			Any <sup>2</sup> finish	Skim <sup>3</sup> only
<b>60 minutes fire resistance</b> (EN)										
③	144	Gyproc SoundBloc	2 x 12.5	4000	56 (51)	-	Severe	44	A206234	-
<b>90 minutes fire resistance</b> (EN)										
①	154	Gyproc SoundBloc	2 x 15	5000	52	53	Severe	52	A206269	A206269S
④	154	Gyproc FireLine	2 x 15	4000	53	55	Severe	53	A206276	A206276S
②	154	Gyproc SoundBloc	2 x 15	5000	56 <sup>4</sup>	57 <sup>4</sup>	Severe	52	A206270	A206270S
<b>120 minutes fire resistance</b> (EN)										
①	154	Gyproc FireLine	2 x 15	5900	50	51	Severe	52	A206273	A206273S
②	154	Gyproc FireLine	2 x 15	5000	52 <sup>4</sup>	53 <sup>4</sup>	Severe	52	A206274	A206274S
④	154	Gyproc FireLine	2 x 15	3000	53	55	Severe	53	A206276	A206276S

▶ For further assistance in choosing the right solution for your project, try our System Selector; an online tool that enables quick and easy filtering by performance criteria. It provides system specific information downloads including BIM (Revit) objects. Go to [gyproc.ie](http://gyproc.ie)

<sup>1</sup> The maximum heights quoted are limited by the fire state field of application or by limiting deflection of L/240 at 200 Pa, whichever is the more onerous.

<sup>2</sup> Sound insulation performance for partitions finished using jointing or plaster skim.

<sup>3</sup> Sound insulation performance for partitions finished with a 2mm skim finish of Gyproc Skimcoat, Carlite Finish or Carlite Ultra Finish plaster.

<sup>4</sup> Increasing the insulation to 50mm Isover Acoustic Roll will not improve the system performance.

**(NB)** The fire resistance and sound insulation performances are for imperforate partitions, walls and ceilings incorporating boards with all joints taped and filled, or skimmed according to Gyproc's recommendations. The quoted performances are achieved only if Gyproc and Isover components are used throughout, and the Company's fixing recommendations are strictly observed. Any variation in the specifications should be checked with Gyproc.

**(NB)** For heights between 4200mm and 8000mm, Gypframe Deep Flange Floor & Ceiling Channel should be used at base and at head (subject to deflection criteria).

## GypWall performance (continued)

### 92mm Gypframe 'C' Studs - double layer board linings

For details of when to specify fire resistance using BS  
 ▶ Refer to C02. S01. P18



Table 9b — Solutions to satisfy the requirements of BS 476: Part 22: 1987

①		②		③		④	
	Two layers of board each side of 92mm Gypframe 'C' Studs at 600mm centres. Linings as in table.		Two layers of board each side of 92mm Gypframe 'C' Studs at 600mm centres. 25mm Isover Acoustic Roll in the cavity. Linings as in table.		Two layers of board each side of 92mm Gypframe 'C' Studs at 600mm centres. 3 x 25mm Isover Acoustic Roll in the cavity. Linings as in table.		Two layers of board each side of 92mm Gypframe 'C' Studs at 600mm centres. 100mm Isover Modular Roll in the cavity. Linings as in table.

▶ Refer to GypWall **ROBUST** and GypWall **EXTREME** sections for single layer Severe Duty solutions

Detail	Partition thickness mm	Board type	Lining thickness mm	Max height <sup>1</sup> mm	Sound insulation $R_w (R_w + C_w)$ dB		Duty rating	Approx. weight kg/m <sup>2</sup>	System reference	
					Any <sup>2</sup> finish	Skim <sup>3</sup> only			Any <sup>2</sup> finish	Skim <sup>3</sup> only
<b>60 minutes fire resistance</b> (BS)										
③	144	Gyproc SoundBloc	2 x 12.5	5700	56 (51)	-	Severe	44	A206234	-
<b>90 minutes fire resistance</b> (BS)										
①	154	Gyproc SoundBloc	2 x 15	5900	52	53	Severe	52	A206269	A206269S
②	154	Gyproc SoundBloc	2 x 15	5900	56 <sup>4</sup>	57 <sup>4</sup>	Severe	52	A206270	A206270S
<b>120 minutes fire resistance</b> (BS)										
①	154	Gyproc FireLine	2 x 15 <sup>5</sup>	5900	50	51	Severe	52	A206273	A206273S
②	154	Gyproc FireLine	2 x 15 <sup>5</sup>	5900	52 <sup>4</sup>	53 <sup>4</sup>	Severe	52	A206274	A206274S
④	154	Gyproc FireLine	2 x 15 <sup>5</sup>	5900	53	55	Severe	53	A206276	A206276S

▶ For further assistance in choosing the right solution for your project, try our System Selector; an online tool that enables quick and easy filtering by performance criteria. It provides system specific information downloads including BIM (Revit) objects. Go to [gyproc.ie](http://gyproc.ie)

<sup>1</sup> Based on a limiting deflection of L/240 at 200 Pa. Greater heights can be achieved through the use of Gypframe 'I' Studs, or reduced stud centres.

<sup>2</sup> Sound insulation performance for partitions finished using jointing or plaster skim.

<sup>3</sup> Sound insulation performance for partitions finished with a 2mm skim finish of Gyproc Skimcoat, Carlite Finish or Carlite Ultra Finish plaster.

<sup>4</sup> Increasing insulation to 50mm Isover Acoustic Roll will not improve this system performance.

<sup>5</sup> 2 x 12.5mm lining thickness is acceptable for 120 minutes BS up to a maximum height of 5700mm but acoustic test data is not available.

**(NB)** The fire resistance and sound insulation performances are for imperforate partitions, walls and ceilings incorporating boards with all joints taped and filled, or skimmed according to Gyproc's recommendations. The quoted performances are achieved only if Gyproc and Isover components are used throughout, and the Company's fixing recommendations are strictly observed. Any variation in the specifications should be checked with Gyproc.

**(NB)** For heights between 4200mm and 8000mm, Gypframe Deep Flange Floor & Ceiling Channel should be used at base and at head (subject to deflection criteria).



Table 10a — Solutions to satisfy the requirements of BS EN 1364-1: 1999

①		②		③		④	
	Two layers of board each side of 92mm Gypframe AcouStuds at 600mm centres. Linings as in table.		Two layers of board each side of 92mm Gypframe AcouStuds at 600mm centres. 25mm Isover Acoustic Roll in the cavity. Linings as in table.		Two layers of board each side of 92mm Gypframe AcouStuds at 600mm centres. 50mm Isover Acoustic Roll in the cavity. Linings as in table.		Two layers of board each side of 92mm Gypframe AcouStuds at 600mm centres. 100mm Isover Modular Roll in the cavity. Linings as in table.

▶ Refer to GypWall ROBUST and GypWall EXTREME sections for single layer Severe Duty solutions

Detail	Partition thickness mm	Board type	Lining thickness mm	Max height <sup>1</sup> mm	Sound insulation $R_w (R_w + C_{tr})$ dB		Duty rating	Approx. weight kg/m <sup>2</sup>	System reference	
					Any <sup>2</sup> finish	Skim <sup>3</sup> only			Any <sup>2</sup> finish	Skim <sup>3</sup> only
<b>60 minutes fire resistance</b> (EN)										
①	144	Gyproc SoundBloc	2 x 12.5	5000	54	55	Severe	52	A206A289	A206A289S
②	144	Gyproc SoundBloc	2 x 12.5	5000	57 (51)	58 (51)	Severe	52	A206A290	A206A290S
③	144	Gyproc SoundBloc	2 x 12.5	5000	58 (53)	59 (53)	Severe	52	A206A291	A206A291S
④	144	Gyproc SoundBloc	2 x 12.5	5000	59 (54)	60 (54)	Severe	52	A206A292	A206A292S
<b>120 minutes fire resistance</b> (EN)										
①	144	Gyproc FireLine	2 x 12.5	3000	51	52	Severe	52	A206A293	A206A293S
③	144	Gyproc FireLine	2 x 12.5	4000	55	56	Severe	52	A206A295	A206A295S
④	144	Gyproc FireLine	2 x 12.5	3000	56	58	Severe	52	A206A296	A206A296S

▶ For further assistance in choosing the right solution for your project, try our System Selector; an online tool that enables quick and easy filtering by performance criteria. It provides system specific information downloads including BIM (Revit) objects. Go to [gyproc.ie](http://gyproc.ie)

<sup>1</sup> The maximum heights quoted are limited by the fire state field of application or by limiting deflection of L/240 at 200 Pa, whichever is the more onerous.

<sup>2</sup> Sound insulation performance for partitions finished using jointing or plaster skim.

<sup>3</sup> Sound insulation performance for partitions finished with a 2mm skim finish of Gyproc Skimcoat, Carlite Finish or Carlite Ultra Finish plaster.

**(NB)** The fire resistance and sound insulation performances are for imperforate partitions, walls and ceilings incorporating boards with all joints taped and filled, or skimmed according to Gyproc's recommendations. The quoted performances are achieved only if Gyproc and Isover components are used throughout, and the Company's fixing recommendations are strictly observed. Any variation in the specifications should be checked with Gyproc.

**(NB)** For heights between 4200mm and 8000mm, Gypframe Deep Flange Floor & Ceiling Channel should be used at base and at head (subject to deflection criteria).

## GypWall performance (continued)

### 92mm Gypframe AcouStuds - double layer board linings

For details of when to specify fire resistance using BS  
 ▶ Refer to C02. S01. P18



Table 10b — Solutions to satisfy the requirements of BS 476: Part 22: 1987

①		②		③		④	
	Two layers of board each side of 92mm Gypframe AcouStuds at 600mm centres. Linings as in table.		Two layers of board each side of 92mm Gypframe AcouStuds at 600mm centres. 25mm Isover Acoustic Roll in the cavity. Linings as in table.		Two layers of board each side of 92mm Gypframe AcouStuds at 600mm centres. 50mm Isover Acoustic Roll in the cavity. Linings as in table.		Two layers of board each side of 92mm Gypframe AcouStuds at 600mm centres. 100mm Isover Modular Roll in the cavity. Linings as in table.

▶ Refer to GypWall **ROBUST** and GypWall **EXTREME** sections for single layer Severe Duty solutions

Detail	Partition thickness mm	Board type	Lining thickness mm	Max height <sup>1</sup> mm	Sound insulation $R_w (R_w + C_{tr})$ dB		Duty rating	Approx. weight kg/m <sup>2</sup>	System reference	
					Any <sup>2</sup> finish	Skim <sup>3</sup> only			Any <sup>2</sup> finish	Skim <sup>3</sup> only
<b>60 minutes fire resistance</b> <span style="border: 1px solid black; border-radius: 50%; padding: 2px;">BS</span>										
①	144	Gyproc SoundBloc	2 x 12.5	5800	54	55	Severe	52	A206A289	A206A289S
②	144	Gyproc SoundBloc	2 x 12.5	5800	57 (51)	58 (51)	Severe	52	A206A290	A206A290S
③	144	Gyproc SoundBloc	2 x 12.5	5800	58 (53)	59 (53)	Severe	52	A206A291	A206A291S
④	144	Gyproc SoundBloc	2 x 12.5	5800	59 (54)	60 (54)	Severe	52	A206A292	A206A292S
<b>120 minutes fire resistance</b> <span style="border: 1px solid black; border-radius: 50%; padding: 2px;">BS</span>										
①	144	Gyproc FireLine	2 x 12.5	5800	51	52	Severe	52	A206A293	A206A293S
②	144	Gyproc FireLine	2 x 12.5	5800	54	55	Severe	52	A206A294	A206A294S
③	144	Gyproc FireLine	2 x 12.5	5800	55	56	Severe	52	A206A295	A206A295S
④	144	Gyproc FireLine	2 x 12.5	5800	56	58	Severe	52	A206A296	A206A296S

▶ For further assistance in choosing the right solution for your project, try our System Selector; an online tool that enables quick and easy filtering by performance criteria. It provides system specific information downloads including BIM (Revit) objects. Go to [gyproc.ie](http://gyproc.ie)

<sup>1</sup> Based on a limiting deflection of L/240 at 200 Pa. Greater heights can be achieved through the use of Gypframe 'I' Studs, or reduced stud centres.

<sup>2</sup> Sound insulation performance for partitions finished using jointing or plaster skim.

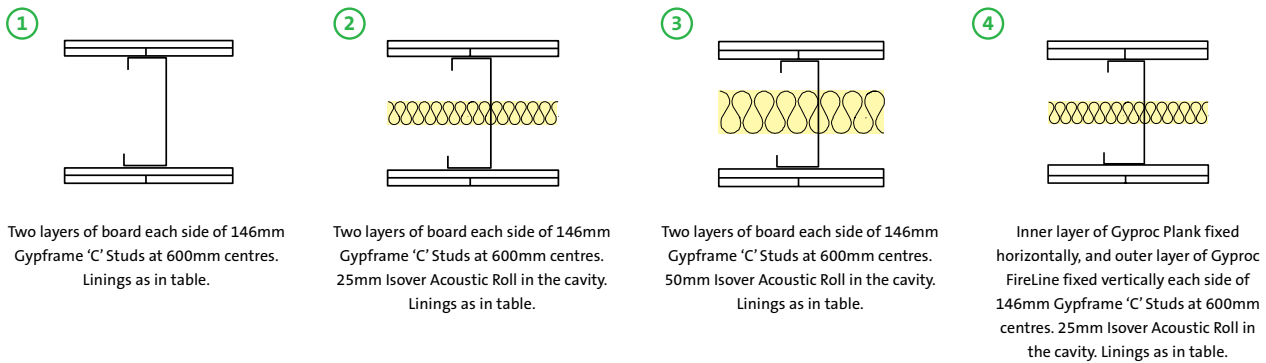
<sup>3</sup> Sound insulation performance for partitions finished with a 2mm skim finish of Gyproc Skimcoat, Carlite Finish or Carlite Ultra Finish plaster.

**NB** The fire resistance and sound insulation performances are for imperforate partitions, walls and ceilings incorporating boards with all joints taped and filled, or skimmed according to Gyproc's recommendations. The quoted performances are achieved only if Gyproc and Isover components are used throughout, and the Company's fixing recommendations are strictly observed. Any variation in the specifications should be checked with Gyproc.

**NB** For heights between 4200mm and 8000mm, Gypframe Deep Flange Floor & Ceiling Channel should be used at base and at head (subject to deflection criteria).



Table 11a — Solutions to satisfy the requirements of BS EN 1364-1: 1999



Detail	Partition thickness mm	Board type	Lining thickness mm	Max height <sup>1</sup> mm	Sound insulation $R_w (R_w + C_w)$ dB		Duty rating	Approx. weight kg/m <sup>2</sup>	System reference	
					Any <sup>2</sup> finish	Skim <sup>3</sup> only			Any <sup>2</sup> finish	Skim <sup>3</sup> only
<b>30 minutes fire resistance</b> (EN)										
①	198	Gyproc WallBoard	2 x 12.5	7600	50	51	Severe	35	A206027	A206027S
①	198	Outer layer Glasroc H TILEBACKER + inner layer Gyproc WallBoard	1 x 12.5 + 1 x 12.5	7600	50	-	Severe	39	H206027	-
<b>60 minutes fire resistance</b> (EN)										
③	198	Gyproc WallBoard	2 x 12.5	4000	51	52	Severe	36	A206149	A206149S
③	198	Outer layer Glasroc H TILEBACKER + inner layer Gyproc WallBoard	1 x 12.5 + 1 x 12.5	4000	51	-	Severe	40	H206149	-
①	198	Gyproc SoundBloc	2 x 12.5	5000	53	54	Severe	43	A206178	A206178S
②	198	Gyproc SoundBloc	2 x 12.5	4000	55 (49)	56 (49)	Severe	43	A206210	A206210S
①	208	Gyproc WallBoard	2 x 15	5000	50	-	Severe	42	A206028	-
②	208	Gyproc WallBoard	2 x 15	4000	51	-	Severe	42	A206060	-
<b>90 minutes fire resistance</b> (EN)										
①	208	Gyproc SoundBloc	2 x 15	3000	56 (50)	57 (50)	Severe	51	A206179	A206179S
③	208	Gyproc SoundBloc	2 x 15	4000	59 (53)	60 (53)	Severe	52	A206243	A206243S
<b>120 minutes fire resistance</b> (EN)										
①	198	Gyproc FireLine	2 x 12.5	4200	50	51	Severe	40	A206091	A206091S
②	198	Gyproc FireLine	2 x 12.5	4000	51	52	Severe	40	A206123	A206123S
①	208	Gyproc FireLine	2 x 15	7900	50	-	Severe	46	A206180	-
②	208	Gyproc FireLine	2 x 15	7800	51	-	Severe	46	A206181	-

► For further assistance in choosing the right solution for your project, try our System Selector; an online tool that enables quick and easy filtering by performance criteria. It provides system specific information downloads including BIM (Revit) objects. Go to [gyproc.ie](http://gyproc.ie)

<sup>1</sup>The maximum heights quoted are limited by the fire state field of application or by limiting deflection of L/240 at 200 Pa, whichever is the more onerous.

<sup>2</sup>Sound insulation performance for partitions finished using jointing or plaster skim.

<sup>3</sup>Sound insulation performance for partitions finished with a 2mm skim finish of Gyproc Skimcoat, Carlite Finish or Carlite Ultra Finish plaster.

**(NB)** The fire resistance and sound insulation performances are for imperforate partitions, walls and ceilings incorporating boards with all joints taped and filled, or skimmed according to Gyproc's recommendations. The quoted performances are achieved only if Gyproc and Isover components are used throughout, and the Company's fixing recommendations are strictly observed. Any variation in the specifications should be checked with Gyproc.

**(NB)** For heights between 4200mm and 8000mm, Gypframe Deep Flange Floor & Ceiling Channel should be used at base and at head (subject to deflection criteria).

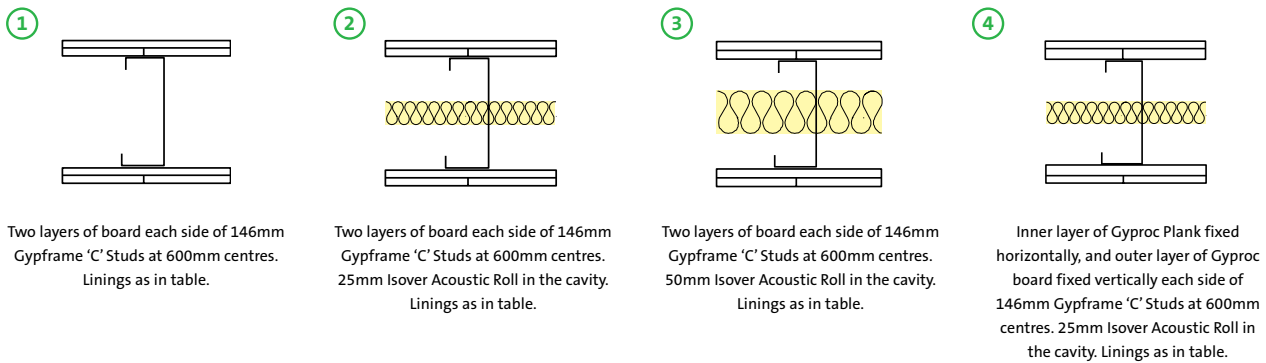
## GypWall performance (continued)

### 146mm Gypframe 'C' Studs - double layer board linings

For details of when to specify fire resistance using BS  
 ▶ Refer to C02. S01. P18



Table 11b — Solutions to satisfy the requirements of BS 476: Part 22: 1987



Detail	Partition thickness mm	Board type	Lining thickness mm	Max height <sup>1</sup> mm	Sound insulation $R_w (R_w + C_{tr})$ dB		Duty rating	Approx. weight kg/m <sup>2</sup>	System reference	
					Any <sup>2</sup> finish	Skim <sup>3</sup> only			Any <sup>2</sup> finish	Skim <sup>3</sup> only
<b>60 minutes fire resistance</b>										
<b>1</b>	198	Gyproc WallBoard	2 x 12.5	7600	50	51	Severe	35	A206027	A206027S
<b>1</b>	198	Outer layer Glasroc H TILEBACKER + inner layer Gyproc WallBoard	1 x 12.5 + 1 x 12.5	7600	50	-	Severe	39	H206027	-
<b>2</b>	198	Gyproc WallBoard	2 x 12.5	7600	51	52	Severe	35	A206059	A206059S
<b>2</b>	198	Outer layer Glasroc H TILEBACKER + inner layer Gyproc WallBoard	1 x 12.5 + 1 x 12.5	7600	51	-	Severe	39	H206059	-
<b>1</b>	198	Gyproc SoundBloc	2 x 12.5	7600	53	54	Severe	43	A206178	A206178S
<b>2</b>	198	Gyproc SoundBloc	2 x 12.5	7600	55 (49)	56 (49)	Severe	43	A206210	A206210S
<b>3</b>	198	Gyproc SoundBloc	2 x 12.5	7600	56 (50)	57 (50)	Severe	43	A206244	A206244S
<b>90 minutes fire resistance</b>										
<b>1</b>	208	Gyproc WallBoard	2 x 15	7900	50	-	Severe	42	A206028	-
<b>2</b>	208	Gyproc WallBoard	2 x 15	7900	51	-	Severe	42	A206060	-
<b>1</b>	208	Gyproc SoundBloc	2 x 15	7900	56 (50)	57 (50)	Severe	51	A206179	A206179S
<b>2</b>	208	Gyproc SoundBloc	2 x 15	7900	58 (52)	-	Severe	51	A206211	-
<b>3</b>	208	Gyproc SoundBloc	2 x 15	7900	59 (53)	60 (53)	Severe	52	A206243	A206243S
<b>120 minutes fire resistance</b>										
<b>1</b>	188	Glasroc F MULTIBOARD	2 x 10	7100	48	-	Severe	40	G106014	-
<b>1</b>	198	Gyproc FireLine	2 x 12.5	7600	50	51	Severe	40	A206091	A206091S
<b>2</b>	198	Gyproc FireLine	2 x 12.5	7600	51	52	Severe	40	A206123	A206123S
<b>4</b>	211	Gyproc Plank + Gyproc FireLine	1 x 19 + 1 x 12.5	7100	51	-	Severe	54	A226002	-

▶ For further assistance in choosing the right solution for your project, try our System Selector; an online tool that enables quick and easy filtering by performance criteria. It provides system specific information downloads including BIM (Revit) objects. Go to [gyproc.ie](http://gyproc.ie)

<sup>1</sup> Based on a limiting deflection of L/240 at 200 Pa. Greater heights can be achieved through the use of Gyproc 'I' Studs, or reduced stud centres.

<sup>2</sup> Sound insulation performance for partitions finished using jointing or plaster skim.

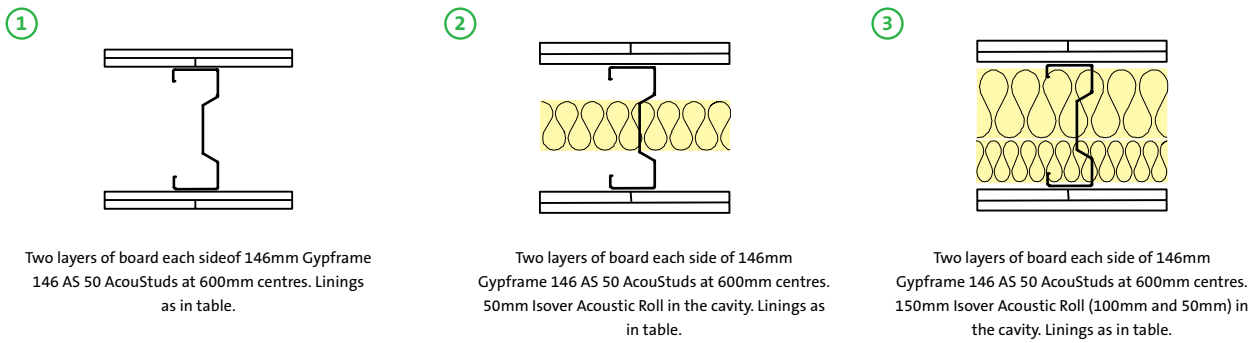
<sup>3</sup> Sound insulation performance for partitions finished with a 2mm skim finish of Gyproc Skimcoat, Carlite Finish or Carlite Ultra Finish plaster.

**NB** The fire resistance and sound insulation performances are for imperforate partitions, walls and ceilings incorporating boards with all joints taped and filled, or skimmed according to Gyproc's recommendations. The quoted performances are achieved only if Gyproc and Isover components are used throughout, and the Company's fixing recommendations are strictly observed. Any variation in the specifications should be checked with Gyproc.

**NB** For heights between 4200mm and 8000mm, Gyproc Deep Flange Floor & Ceiling Channel should be used at base and at head (subject to deflection criteria).



Table 12a — Solutions to satisfy the requirements of BS EN 1364-1: 1999



Detail	Partition thickness mm	Board type	Lining thickness mm	Max partition height <sup>1</sup> mm	Sound insulation $R_w (R_w + C_{tr})$ dB		Duty rating	Approx. weight kg/m <sup>2</sup>	System reference	
					Any <sup>2</sup> finish	Skim <sup>3</sup> only			Any <sup>2</sup> finish	Skim <sup>3</sup> only
<b>60 minutes fire resistance</b> (EN)										
①	208	Gyproc WallBoard	2 x 15	5000	52 (47)	54 (47)	Severe	42	A206A028	A206A028S
①	208	Gyproc SoundBloc	2 x 15	5000	59 (54)	60 (54)	Severe	51	A206A179	A206A179S
③	208	Gyproc SoundBloc	2 x 15	5000	61 (57)	63 (57)	Severe	53	A206A255	A206A255S
<b>90 minutes fire resistance</b> (EN)										
①	198	Gyproc FireLine	2 x 12.5	7800	52 (48)	53 (48)	Severe	40	A206A091	A206A091S
①	208	Gyproc SoundBloc	2 x 15	4000	59 (54)	60 (54)	Severe	51	A206A179	A206A179S
②	208	Gyproc SoundBloc	2 x 15	4000	61 (56)	62 (56)	Severe	52	A206A243	A206A243S
③	208	Gyproc SoundBloc	2 x 15	4000	61 (57)	63 (57)	Severe	53	A206A255	A206A255S
<b>120 minutes fire resistance</b> (EN)										
①	198	Gyproc FireLine	2 x 12.5	4200	52 (48)	53 (48)	Severe	40	A206A091	A206A091S
①	208	Gyproc FireLine	2 x 15	8100	52 (47)	54 (47)	Severe	50	A206A180	A206A180S

► For further assistance in choosing the right solution for your project, try our System Selector; an online tool that enables quick and easy filtering by performance criteria. It provides system specific information downloads including BIM (Revit) objects. Go to [gyproc.ie](http://gyproc.ie)

<sup>1</sup> The maximum heights quoted are limited by the fire state field of application or by limiting deflection of L/240 at 200 Pa, whichever is the more onerous.

<sup>2</sup> Sound insulation performance for partitions finished using jointing or plaster skim.

<sup>3</sup> Sound insulation performance for partitions finished with a 2mm skim finish of Gyproc Skimcoat, Carlite Finish or Carlite Ultra Finish plaster.

**(NB)** The fire resistance and sound insulation performances are for imperforate partitions, walls and ceilings incorporating boards with all joints taped and filled, or skimmed according to Gyproc's recommendations. The quoted performances are achieved only if Gyproc and Isover components are used throughout, and the Company's fixing recommendations are strictly observed. Any variation in the specifications should be checked with Gyproc.

**(NB)** For heights between 4200mm and 8000mm, Gypframe Deep Flange Floor & Ceiling Channel should be used at base and at head (subject to deflection criteria).

**(NB)** For heights over 8000mm, Gypframe Extra Deep Flange Floor & Ceiling Channel should be used at head and base.

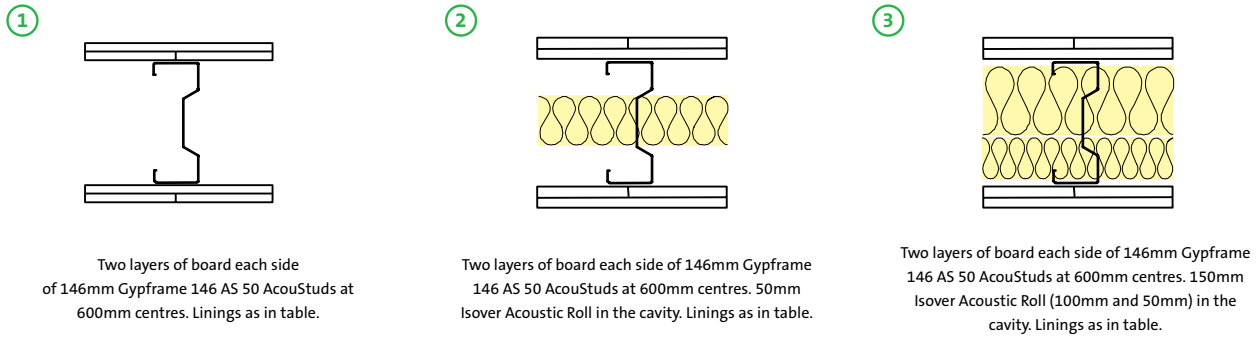
## GypWall performance (continued)

### 146mm Gypframe AcouStuds - double layer board linings

For details of when to specify fire resistance using BS  
 ▶ Refer to C02. S01. P18



Table 12b — Solutions to satisfy the requirements of BS 476: Part 22: 1987



Detail	Partition thickness mm	Board type	Lining thickness mm	Max partition height <sup>1</sup> mm	Sound insulation $R_w (R_w + C_{tr})$ dB		Duty rating	Approx. weight kg/m <sup>2</sup>	System reference	
					Any <sup>2</sup> finish	Skim <sup>3</sup> only			Any <sup>2</sup> finish	Skim <sup>3</sup> only
<b>90 minutes fire resistance</b> (BS)										
①	208	Gyproc WallBoard	2 x 15	8100	52 (47)	54 (47)	Severe	42	A206A028	A206A028S
①	208	Gyproc SoundBloc	2 x 15	8100	59 (54)	60 (54)	Severe	51	A206A179	A206A179S
②	208	Gyproc SoundBloc	2 x 15	8100	61 (56)	62 (56)	Severe	52	A206A243	A206A243S
③	208	Gyproc SoundBloc	2 x 15	8100	61 (57)	63 (57)	Severe	53	A206A255	A206A255S
<b>120 minutes fire resistance</b> (BS)										
①	198	Gyproc FireLine	2 x 12.5	7800	52 (48)	53 (48)	Severe	40	A206A091	A206A091S

▶ For further assistance in choosing the right solution for your project, try our System Selector; an online tool that enables quick and easy filtering by performance criteria. It provides system specific information downloads including BIM (Revit) objects. Go to [gyproc.ie](http://gyproc.ie)

<sup>1</sup>Based on a limiting deflection of L/240 at 200 Pa. Greater heights can be achieved through the use of Gypframe 'I' Studs, or reduced stud centres.

<sup>2</sup>Sound insulation performance for partitions finished using jointing or plaster skim.

<sup>3</sup>Sound insulation performance for partitions finished with a 2mm skim finish of Gyproc Skimcoat, Carlite Finish or Carlite Ultra Finish plaster.

**(NB)** The fire resistance and sound insulation performances are for imperforate partitions, walls and ceilings incorporating boards with all joints taped and filled, or skimmed according to Gyproc's recommendations. The quoted performances are achieved only if Gyproc and Isover components are used throughout, and the Company's fixing recommendations are strictly observed. Any variation in the specifications should be checked with Gyproc.

**(NB)** For heights between 4200mm and 8000mm, Gypframe Deep Flange Floor & Ceiling Channel should be used at base and at head (subject to deflection criteria).

**(NB)** For heights over 8000mm, Gypframe Extra Deep Flange Floor & Ceiling Channel should be used at head and base.

## Building design

Whilst our GypWall partition systems are non-loadbearing, they are able to provide resistance to levels of horizontal uniformly distributed loads in accordance with BS 6399.

► Refer to C02. S01. P37 – Robustness.

## Planning – key factors

GypWall comprises Gypframe 'C' Studs installed at 600mm centres within Gypframe Floor & Ceiling Channels. The position of services and heavy fixtures should be pre-determined and their installation planned into the frame erection stage.

## Fixing floor and ceiling channels

Gypframe Floor & Ceiling Channels must be securely fixed with a row of fixings at 600mm maximum centres. For 94mm and 148mm channels, two rows of staggered fixings are required, each row at 600mm centres and each fixing 25mm in from the flange. If the floor is uneven, a 38mm thick timber sole plate equal to the width of the channel should be used.

If the concrete or screeded floor is new, consideration should be given to the installation of a damp-proof membrane between the floor surface and the channel or sole plate.

## Splicing

To extend studs, overlap by 600mm (minimum). Fix together using Gyproc Wafer Head Drywall Screws or steel pop rivets (two to each flange).

► Refer to Partitions introduction C04. S01. P110 – construction detail 1.

## Partition to structural steelwork junctions

When designing the layout of rooms requiring separation by sound insulating walls abutting structural steelwork, consideration should be given to the potential loss of sound insulation performance through the steelwork.

► Refer to C02. S01. P21 – Building acoustics.

## Door openings

The designer should consider thickness tolerances of the partition types in relation to the proposed door frame detail. Standard door frame detailing to suit BS 5234 Light and Medium Duty applications is shown in Partitions introduction C04. S01. P118 – construction detail 25. Detailing to satisfy BS 5234 requirements for Heavy and Severe Duty Rating is shown in Partitions introduction C04. S01. P119 – construction details 26 and 27. The door manufacturer should also be consulted in relation to door details.

Specialist advice should be sought from door manufacturers and Acoustic Consultants to ensure the required acoustic performance is achieved. This becomes more important as acoustic requirements increase.

## Framing surround for openings

Where services such as horizontal ducts, fire dampers and access panels are required to penetrate the wall, their position should be pre-determined in order that a framed opening can be provided. The openings should be constructed using established metal stud procedures.

► Refer to Partitions introduction C04. S01. P121 - construction details 28-31.

## Cavity fire barriers

Minimum 12.5mm Gyproc plasterboard, screw-fixed into the web of perimeter channels or vertical studs, will provide a satisfactory closure to flame or smoke.

► Refer to C06. S06. P422 – Cavity fire barriers.

## Control joints

Control joints may be required in the partition to relieve stresses induced by expansion and contraction of the structure (refer to Partitions introduction C04. S01. P115 – construction detail 12). They should coincide with movement joints within the surrounding structure.

## Deflection heads

Partition head deflection designs may be necessary to accommodate deflections in the supporting floor. Deflection heads may also be required to the underside of roof structures subjected to positive and negative pressures.

► Refer to Partitions introduction C04. S01. P116 – construction details 15-22.

To minimise the loss of acoustic performance:

► Refer to C02. S01. P21 – Building acoustics.

## Services

### Penetrations

Penetrations of fire-resistant or sound-insulating constructions for services need careful consideration to ensure that the performance of the element is not downgraded. Consideration also needs to be given to the services themselves so they do not act as the mechanism of fire spread or sound transmission.

► Refer to C02. S01. P41 – Service installations.



## Handy hint

Where access is limited to one side of the head, e.g. M+E cages already installed in corridors

► Refer to C05. S02. P291 - ShaftWall.

## GypWall design (continued)

### Electrical

The installation of electrical services should be carried out in accordance with *BS 7671*. The cut-outs in the studs can be used for routing electrical and other small services (refer to Partitions introduction C04. S01. P110 – construction detail 2). Switch boxes and socket outlets can be supported from Gypframe 99 FC 50 Fixing Channel fixed horizontally between studs, or a high performance socket box detail used where higher acoustic performance is required.

Where Gypframe AcouStuds are used, services are routed through 50mm x 28mm 'H' shaped push-outs, at the same centres as shown in Partitions introduction C04. S01. P110 – construction detail 2a for conventional cut-outs. Cables should be protected by conduit, or other suitable precautions taken to prevent abrasion when they pass through the metal frame. Service cut-outs should be aligned to allow easy installation of service. If studs require cutting, cut from the same end of each stud to ensure cut-out alignment.

### Independent support

When designing for the installation of services such as fire dampers and associated ductwork through a GypWall partition, consideration should be given to the size and weight of the damper - this will determine whether it can be supported directly from the partition or needs to be independently supported from the structure.

- ▶ Refer to Partitions introduction C04. S01. P122 – construction details 29-31.

### Fixtures

Lightweight fixtures can be made directly to the partition linings. Medium weight fixtures can be made to Gypframe 99 FC 50 Fixing Channel. Heavyweight fixtures (to *BS 5234*) such as wash basins and wall cupboards, can be fixed using plywood secured by Gypframe Service Support Plates.

- ▶ Refer to C02. S01. P41 – Service installations.

### Access for maintenance

Gyproc Profiflex Access Panels are available to provide access for maintenance. Access panels must be fully compatible with drywall construction and match the fire rating of the partition.

- ▶ Please contact our Technical Department for further information:  
ROI: 1800 744480  
NI: 08453990159  
Email: tech.ie@saint-gobain.com

### Board finishing

- ▶ Refer to C08. S01. P483 – Finishes.

### Tiling

Tiles up to 32kg/m<sup>2</sup> can be applied to the surface of lightweight partition systems.

- ▶ Refer to C08. S04. P498 – Tiling.

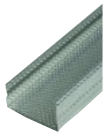
### Construction details

For standard GypWall construction details

- ▶ Refer to Partitions introduction C04. S01. P110 – construction details.

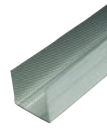
# GypWall system components

## Gypframe metal components



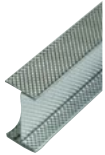
### Gypframe 'C' Studs (48 S 50, 70 S 50, 70 S 60, 92 S 50, 92 S 60, 146 S 50, 146 S 60)

Vertical stud providing acoustic and structural performances designed to receive fixing of board to both sides.



### Gypframe Extra Deep Flange Floor & Ceiling Channels (50 EDC 70, 72 EDC 80, 94 EDC 70, 148 EDC 80)

Floor and ceiling channels with extra deep flanges for retaining the Gypframe studs at floor and ceiling junctions for partitions over 8000mm high. Also used around openings and in deflection heads (maximum 50mm deflection).



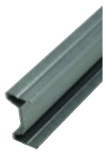
### Gypframe 'I' Studs (48 I 50, 60 I 50, 60 I 70, 70 I 50, 70 I 70, 92 I 90, 146 I 80, 146 TI 90)

Enhanced strength stud that allows for increased partition height, designed to receive fixing of board.



### Gypframe 99 FC 50 Fixing Channel

A versatile metal fixing channel used to support medium weight fixtures on walls.



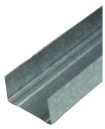
### Gypframe AcouStud (70 AS 50, 92 AS 50, 146 AS 50)

Vertical stud providing enhanced acoustic and structural performances designed to receive fixing of board to both sides.



### Gypframe GF51 Fixing Strap

Used to support horizontal board joints and within deflection heads.



### Gypframe Folded Edge Standard Floor & Ceiling Channels (50 FEC 50, 62 FEC 50, 72 FEC 50, 94 FEC 50, 148 FEC 50)

Standard floor and ceiling channels for retaining the Gypframe studs at floor and ceiling junctions and around openings to heights not exceeding 4200mm.



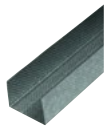
### Gypframe GFT1 Fixing T

Used to support horizontal board joints.



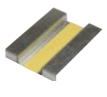
### Gypframe GA6 Splayed Angle

Steel angle providing framing stability and board support.



### Gypframe Deep Flange Floor & Ceiling Channels (FE50 DC 60, FE62 DC 60, FE72 DC 60, FE94 DC 60, FE148 DC 60)

Floor and ceiling channels with deep flanges for retaining the Gypframe studs at floor and ceiling junctions for partitions 4200mm to 8000mm high. Also used around openings and in deflection heads (maximum 30mm deflection).



### Gypframe Service Support Plate

For installation of 18mm plywood within a partition cavity to support medium to heavyweight fixtures.



### Gypframe GA5 Internal Fixing Angle

Widely used in construction to provide support, fixing and additional strength to wall, ceiling and encasement framing.

## Board products



### Gyproc WallBoard

Standard gypsum plasterboard.



### Gyproc SoundBloc<sup>1</sup>

Gypsum plasterboard with a high density core for enhanced sound insulation performance.



### Gyproc Moisture Resistant

Gypsum plasterboard with moisture resistant additives in the core and special green lining paper for easy recognition.



### Gyproc DuraLine

Gypsum plasterboard with fire resistant additives and a high density core for enhanced sound insulation and impact resistance performance.



### Gyproc FireLine<sup>1</sup>

Gypsum plasterboard with fire resistant additives.



### Gyproc Plank

Standard gypsum plasterboard located as an inner layer.

<sup>1</sup> Also available in a Moisture Resistant (MR) version. MR boards are specified in intermittent wet use areas.

## GypWall system components (continued)

### Board products



#### Glasroc H TILEBACKER<sup>2</sup>

Non-combustible glass-reinforced gypsum board with a water resistant pre-primed acrylic coating to receive tiling.



#### Glasroc F FIRECASE

Non-combustible glass-reinforced gypsum board. Used to form deflection head.



#### Glasroc F MULTIBOARD

Non-combustible glass-reinforced gypsum board.



#### Gyproc CoreBoard

Gypsum plasterboard with fire and moisture resistant additives. Used to form deflection head.

<sup>2</sup> Glasroc H TILEBACKER is suitable for use in high moisture environments.

### Fixing products



#### Gyproc Drywall Screws

Corrosion resistant self-tapping steel screws for fixing board-to-timber and board-to-metal framing less than 0.8mm thick.



#### Gyproc Jack-Point Screws

For fixing boards to Gypframe metal framing 0.8mm thick or greater ('I' studs 0.6mm thick and greater).



#### Gyproc Collated Drywall Screws

Corrosion resistant self-tapping steel screws for fixing board-to-timber and board-to-metal framing less than 0.8mm thick.



#### Gyproc Wafer Head Jack-Point Screws

Corrosion resistant self-tapping steel screws for fixing metal to metal framing 0.8mm thick or greater ('I' studs 0.6mm thick or greater).



#### Gyproc Wafer Head Drywall Screws

Corrosion resistant self-tapping steel screws for fixing metal to metal framing less than 0.8mm thick ('I' studs less than 0.6mm thick).

### Plasterboard accessories



#### Gyproc Jointing Materials

Jointing compounds, ready mixes and adhesives for reinforcement and finishing of board joints.



#### Gyproc FireStrip

A soft extruded linear intumescent gap sealer to maintain fire resistance located directly to the underside of the soffit when forming a deflection head.



#### Gyproc Sealant

Used to seal air paths for optimum sound insulation.



#### Gyproc Control Joint

To accommodate structural movement of up to 7mm.



#### Gyproc Paper Joint Tape

A paper tape designed for reinforcement of flat joints or internal angles.



#### Gyproc Drywall Primer

Used to prepare for painting. Tub contents 10 litre.

## GypWall system components (continued)

### Finishing products



#### Gyproc Skimcoat

To provide a plaster skim finish on most common backgrounds including undercoat plasters and plasterboard. Can provide enhanced acoustic performance.



#### Gyproc Carlite Finish

To provide a plaster skim finish on most common backgrounds including undercoat plasters and plasterboard. Can provide enhanced acoustic performance.



#### Gyproc Carlite Ultra Finish

Offers all the benefits of Gyproc Skimcoat and Gyproc Carlite Finish with a reduced set time of 90-120mins, making it ideal for smaller jobs.



#### Gyproc Magnetic Plaster

To provide a plaster skim finish that provides an attraction to magnets used to finish a wide range of backgrounds, including undercoat plasters and plasterboard.



#### Plaster accessories

Designed for reinforcement and finishing of board joints before plaster skimming.

### Insulation products



#### Isover Acoustic Roll

Glass mineral wool for enhanced acoustic performance.



#### Isover Modular Roll

Glass mineral wool for enhanced acoustic performance.

#### Stone mineral wool (by others)

For fire-stopping. Various densities - refer to details

### Access panels (▶ Refer to the Gyproc Technical Department for details)



#### Profilex Access Panel

Panel for access to cavity.

# GypWall system installation overview

This is intended to be a basic description of how the system is installed.



Appropriate Gypframe channels are suitably fixed to the floor and soffit.



Gypframe 'C' Studs are suitably fixed to abutments.



Gypframe studs are then friction fitted into the Gypframe Floor & Ceiling Channels at required centres.



Door openings are constructed to suit the partitions' duty rating.



The perimeter of the partition is then sealed on both sides with Gyproc Sealant.



M&E services can be located within the partition cavity.



Isover insulation can also be added to the partition cavity for increased acoustic performance.



Gyproc plasterboards or Glasroc specialist boards are fixed to the Gypframe framework with Gyproc Drywall Screws.



## Additional information

Refer to health and safety sections for guidance on the safe use of Gypframe metal, tools, gypsum products, manual handling and other relevant factors

For full installation details, refer to the **Gyproc Installation Guide**, available to download from [gypoc.ie](http://gypoc.ie).

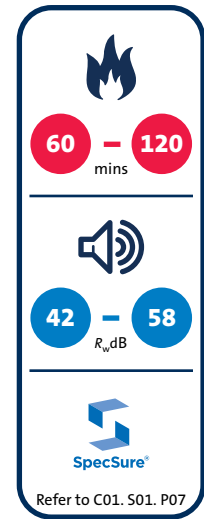
# GypWall ROBUST

Durable impact resistant partition system



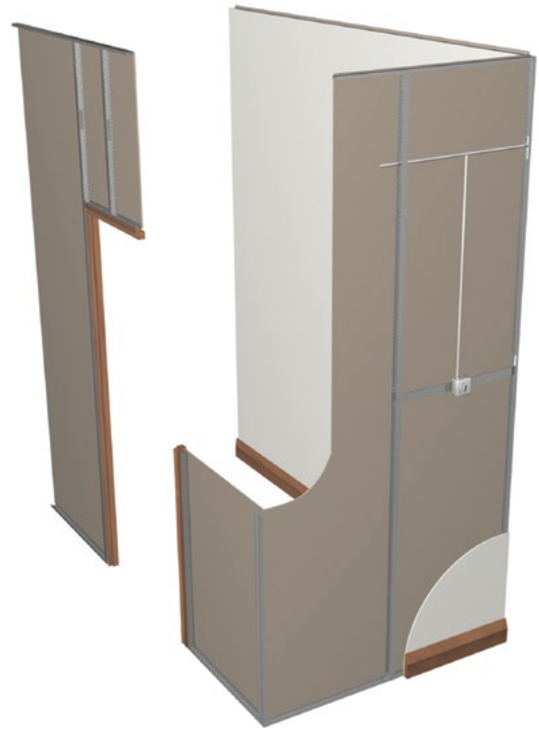
# GypWall ROBUST

**GypWall ROBUST** is a highly impact-resistant partition system for use where a more durable solution is required. All **GypWall ROBUST** systems utilise Gyproc DuraLine board to give enhanced levels of resistance to damage from everyday occurrences, such as school bags being knocked against corridor walls as pupils move from one lesson to the next. As a result, the system provides a lightweight, non-loadbearing partition ideal for all types of commercial, healthcare and educational buildings that experience high levels of human traffic.



## Key benefits

- Achieves Severe Duty Rating to BS 5234 with only a single layer of Gyproc DuraLine plasterboard to each side of the partition
- Reduced maintenance cycles due to impact resistant nature of Gyproc DuraLine plasterboard
- Fully compatible with other Gyproc systems, **GypWall ROBUST** can be specified in areas of the building that really need it, whilst other GypWall partitions can be used in lower duty performance zones for optimal project value
- Increased levels of acoustic performance are available when **GypWall ROBUST** is specified with Gypframe 92 AS 50 AcouStud – a commonly chosen solution for school classrooms and hospital consulting rooms



## You may also be interested in...

For areas of a building where extreme levels of duty rating may be required, for example a school corridor or hospital circulation space, **GypWall EXTREME** provides the answer.

► Refer to C04.S04.P179 - **GypWall EXTREME**

# GypWall robust performance

## 70mm Gypframe 'C' Studs - single layer board linings

For details of when to specify fire resistance using EN  
 ▶ Refer to C02. S01. P05



Table 1a — Solutions to satisfy the requirements of BS EN 1364-1: 1999

- ①

One layer of board each side of Gypframe 70 S 50 'C' Studs at 600mm centres. Linings as in table.

②

One layer of board each side of Gypframe 70 S 50 'C' Studs at 600mm centres. 25mm Isover Acoustic Roll in the cavity. Linings as in table.

③

One layer of board each side of Gypframe 70 S 50 'C' Studs at 600mm centres. 50mm Isover Acoustic Roll in the cavity. Linings as in table.
- ④

One layer of board each side of Gypframe 70 S 50 'C' Studs at 600mm centres. 80mm Isover Modular Roll in the cavity. Linings as in table.

⑤

One layer of board each side of Gypframe 70 S 50 'C' Studs at 600mm centres. 75mm Isover Acoustic Slab in the cavity. Linings as in table.

Detail	Partition thickness mm	Board type	Lining thickness mm	Max. partition height <sup>1</sup> mm	Sound insulation $R_w$ dB		Duty rating	Approx. weight kg/m <sup>2</sup>	System reference	
					Any finish <sup>2</sup>	Skim only <sup>3</sup>			Any finish <sup>2</sup>	Skim only <sup>3</sup>
<b>60 minutes fire resistance</b> <span style="border: 1px solid black; border-radius: 50%; padding: 2px;">EN</span>										
①	102	Gyproc DuraLine	1 x 15	3800	42	43	Severe	29	Q606043	Q606043S
②	102	Gyproc DuraLine	1 x 15	3800	47	-	Severe	29	Q606044	-
③	102	Gyproc DuraLine	1 x 15	3800	48	50	Severe	29	Q606045	Q606045S
④	102	Gyproc DuraLine	1 x 15	3800	50	-	Severe	29	Q606047	-
⑤	102	Gyproc DuraLine	1 x 15	3800	50	51	Severe	29	Q606048	-

▶ For further assistance in choosing the right solution for your project, try our System Selector; an online tool that enables quick and easy filtering by performance criteria. It provides system specific information downloads including BIM (Revit) objects. Go to [gyproc.ie](http://gyproc.ie)

<sup>1</sup> The maximum heights quoted are limited by the fire state field of application or by limiting deflection of L/240 at 200 Pa, whichever is the more onerous.

<sup>2</sup> Sound insulation performance for partitions finished using jointing or plaster skim.

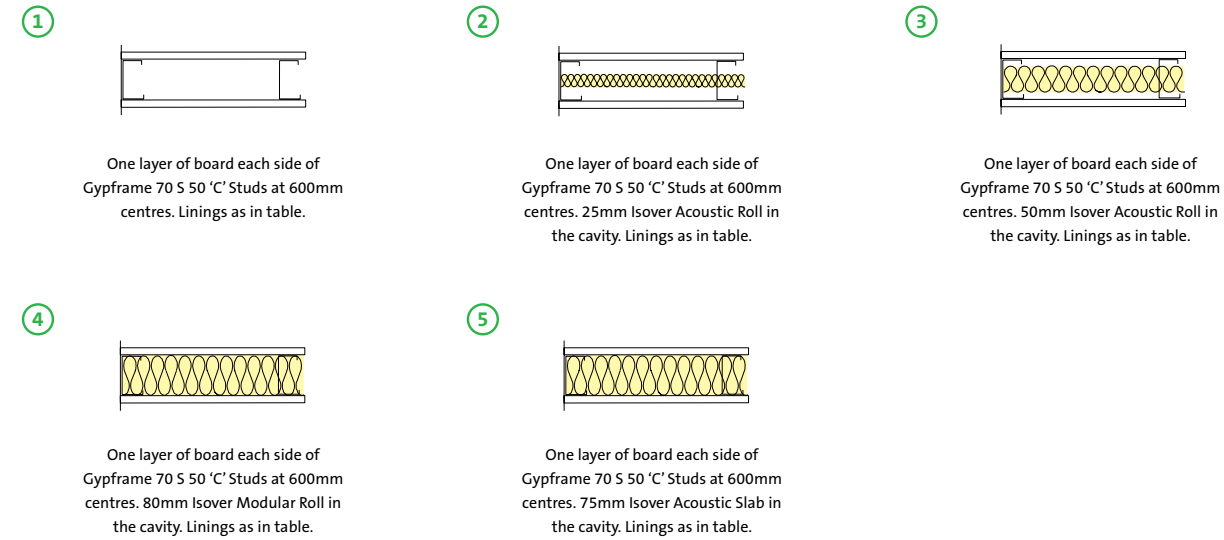
<sup>3</sup> Sound insulation performance for partitions finished with a 2mm skim finish of Gyproc Finish Plasters.

**NB** The fire resistance and sound insulation performances are for imperforate partitions, but incorporating deflection heads, with all joints taped and filled or skimmed according to Gyproc's recommendations. The quoted performances are achieved only if Gyproc and Isover components are used throughout, and the Company's fixing recommendations are strictly observed. Any variation in the specifications should be checked with Gyproc.

**NB** Gypframe Deep Flange Floor & Ceiling Channel or Gypframe Extra Deep Flange Floor & Ceiling Channel should be used at base and at head (subject to deflection criteria).



Table 1b — Solutions to satisfy requirements of BS 476: Part 22: 1987



Detail	Partition thickness mm	Board type	Lining thickness mm	Max. partition height <sup>1</sup> mm	Sound insulation $R_w$ dB		Duty rating	Approx. weight kg/m <sup>2</sup>	System reference	
					Any finish <sup>2</sup>	Skim only <sup>3</sup>			Any finish <sup>2</sup>	Skim only <sup>3</sup>
<b>60 minutes fire resistance</b>										
①	102	Gyproc DuraLine	1 x 15	3800	42	43	Severe	29	Q606043	Q606043S
②	102	Gyproc DuraLine	1 x 15	3800	47	-	Severe	29	Q606044	-
③	102	Gyproc DuraLine	1 x 15	3800	48	50	Severe	29	Q606045	Q606045S
④	102	Gyproc DuraLine	1 x 15	3800	50	-	Severe	29	Q606047	-
⑤	102	Gyproc DuraLine	1 x 15	3800	50	51	Severe	29	Q606048	-

▶ For further assistance in choosing the right solution for your project, try our System Selector; an online tool that enables quick and easy filtering by performance criteria. It provides system specific information downloads including BIM (Revit) objects. Go to [gyproc.ie](http://gyproc.ie)

<sup>1</sup>Based on a limiting deflection of L/240 at 200 Pa. Greater heights can be achieved through the use of reduced stud centres.

<sup>2</sup>Sound insulation performance for partitions finished using jointing or plaster skim.

<sup>3</sup>Sound insulation performance for partitions finished with a 2mm skim finish of Gyproc Finish Plasters.

**NB** The fire resistance and sound insulation performances are for imperforate partitions, but incorporating deflection heads, with all joints taped and filled or skimmed according to Gyproc's recommendations. The quoted performances are achieved only if Gyproc and Isover components are used throughout, and the Company's fixing recommendations are strictly observed. Any variation in the specifications should be checked with Gyproc.

**NB** Gypframe Deep Flange Floor & Ceiling Channel or Gypframe Extra Deep Flange Floor & Ceiling Channel should be used at base and at head (subject to deflection criteria).

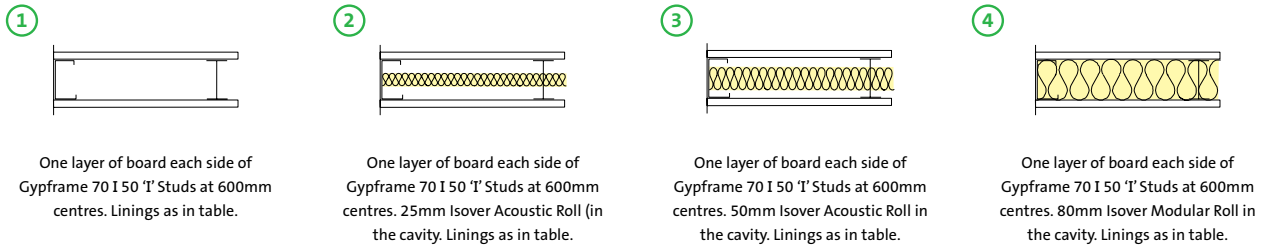
## GypWall robust performance (continued)

### 70mm Gypframe 'I' Studs - single layer board linings

For details of when to specify fire resistance using EN  
 ▶ Refer to C02. S01. P05



Table 2a — Solutions to satisfy the requirements of BS EN 1364-1: 1999



Detail	Partition thickness mm	Board type	Lining thickness mm	Max. partition height <sup>1</sup> mm	Sound insulation $R_w$ dB	Duty rating	Approx. weight kg/m <sup>2</sup>	System reference
<b>60 minutes fire resistance</b>								
①	102	Gyproc DuraLine	1 x 15	4000	42	Severe	29	Q606049
②	102	Gyproc DuraLine	1 x 15	4000	47	Severe	29	Q606050
③	102	Gyproc DuraLine	1 x 15	4000	48	Severe	29	Q606051
④	102	Gyproc DuraLine	1 x 15	4000	50	Severe	29	Q606052

▶ For further assistance in choosing the right solution for your project, try our System Selector; an online tool that enables quick and easy filtering by performance criteria. It provides system specific information downloads including BIM (Revit) objects. Go to [gyproc.ie](http://gyproc.ie)

<sup>1</sup> The maximum heights quoted are limited by the fire state field of application or by limiting deflection of L/240 at 200 Pa, whichever is the more onerous.

**NB** The fire resistance and sound insulation performances are for imperforate partitions, but incorporating deflection heads, with all joints taped and filled or skimmed according to Gyproc's recommendations. The quoted performances are achieved only if Gyproc and Isover components are used throughout, and the Company's fixing recommendations are strictly observed. Any variation in the specifications should be checked with Gyproc.

**NB** Gypframe Deep Flange Floor & Ceiling Channel or Gypframe Extra Deep Flange Floor & Ceiling Channel should be used at base and at head (subject to deflection criteria).

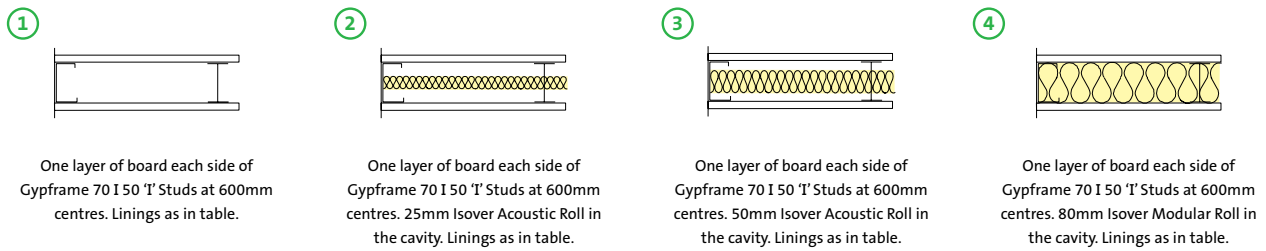
## GypWall robust performance (continued)

### 70mm Gypframe 'I' Studs - single layer board linings

For details of when to specify fire resistance using BS  
 ▶ Refer to C02. S01. P05



Table 2b — Solutions to satisfy requirements of BS 476: Part 22: 1987



Detail	Partition thickness mm	Board type	Lining thickness mm	Max. partition height mm	Sound insulation $R_w$ dB	Duty rating	Approx. weight kg/m <sup>2</sup>	System reference
<b>60 minutes fire resistance</b> <span style="border: 1px solid black; border-radius: 50%; padding: 2px;">BS</span>								
①	102	Gyproc DuraLine	1 x 15	4000	42	Severe	29	Q606049
②	102	Gyproc DuraLine	1 x 15	4000	47	Severe	29	Q606050
③	102	Gyproc DuraLine	1 x 15	4000	48	Severe	29	Q606051
④	102	Gyproc DuraLine	1 x 15	4000	50	Severe	29	Q606052

▶ For further assistance in choosing the right solution for your project, try our System Selector; an online tool that enables quick and easy filtering by performance criteria. It provides system specific information downloads including BIM (Revit) objects. Go to [gyproc.ie](http://gyproc.ie)

**NB** The fire resistance and sound insulation performances are for imperforate partitions, but incorporating deflection heads, with all joints taped and filled or skimmed according to Gyproc's recommendations. The quoted performances are achieved only if Gyproc and Isover components are used throughout, and the Company's fixing recommendations are strictly observed. Any variation in the specifications should be checked with Gyproc.

**NB** Gypframe Deep Flange Floor & Ceiling Channel or Gypframe Extra Deep Flange Floor & Ceiling Channel should be used at base and at head (subject to deflection criteria).

## GypWall robust performance (continued)

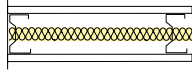
### 70mm Gypframe AcouStuds - single layer board linings

For details of when to specify fire resistance using EN  
 ► Refer to C02. S01. P05



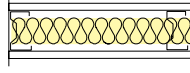
Table 3a — Solutions to satisfy the requirements of BS EN 1364-1: 1999

①



One layer of board each side of Gypframe 70 AS 50 AcouStuds at 600mm centres. 25mm Isover Acoustic Roll in the cavity. Linings as in table.

②



One layer of board each side of Gypframe 70 AS 50 AcouStuds at 600mm centres. 50mm Isover Acoustic Roll in the cavity. Linings as in table.

Detail	Partition thickness mm	Board type	Lining thickness mm	Max. partition height <sup>1</sup> mm	Sound insulation $R_w$ dB		Duty rating	Approx. weight kg/m <sup>2</sup>	System reference	
					Any finish <sup>2</sup>	Skim only <sup>3</sup>			Any finish <sup>2</sup>	Skim only <sup>3</sup>
<b>60 minutes fire resistance</b>										
①	102	Gyproc DuraLine	1 x 15	4000	48	49	Severe	29	Q606A044	Q606A044S
②	102	Gyproc DuraLine	1 x 15	4000	50	51	Severe	29	Q606A046	Q606A046S

► For further assistance in choosing the right solution for your project, try our System Selector; an online tool that enables quick and easy filtering by performance criteria. It provides system specific information downloads including BIM (Revit) objects. Go to [gyproc.ie](http://gyproc.ie)

<sup>1</sup> The maximum heights quoted are limited by the fire state field of application or by limiting deflection of L/240 at 200 Pa, whichever is the more onerous.

<sup>2</sup> Sound insulation performance for partitions finished using jointing or plaster skim.

<sup>3</sup> Sound insulation performance for partitions finished with a 2mm skim finish of Gyproc Finish Plasters.

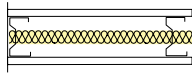
**NB** The fire resistance and sound insulation performances are for imperforate partitions, but incorporating deflection heads, with all joints taped and filled or skimmed according to Gyproc's recommendations. The quoted performances are achieved only if Gyproc and Isover components are used throughout, and the Company's fixing recommendations are strictly observed. Any variation in the specifications should be checked with Gyproc.

**NB** Gypframe Deep Flange Floor & Ceiling Channel or Gypframe Extra Deep Flange Floor & Ceiling Channel should be used at base and at head (subject to deflection criteria).



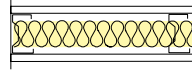
Table 3b — Solutions to satisfy requirements of BS 476: Part 22: 1987

①



One layer of board each side of Gypframe 70 AS 50 AcouStuds at 600mm centres. 25mm Isover Acoustic Roll in the cavity. Linings as in table.

②



One layer of board each side of Gypframe 70 AS 50 AcouStuds at 600mm centres. 50mm Isover Acoustic Roll in the cavity. Linings as in table.

Detail	Partition thickness mm	Board type	Lining thickness mm	Max. partition height <sup>1</sup> mm	Sound insulation $R_w$ dB		Duty rating	Approx. weight kg/m <sup>2</sup>	System reference	
					Any finish <sup>2</sup>	Skim only <sup>3</sup>			Any finish <sup>2</sup>	Skim only <sup>3</sup>
<b>60 minutes fire resistance</b>										
①	102	Gyproc DuraLine	1 x 15	4000	48	49	Severe	29	Q606A044	Q606A044S
②	102	Gyproc DuraLine	1 x 15	4000	50	51	Severe	29	Q606A046	Q606A046S

▶ For further assistance in choosing the right solution for your project, try our System Selector; an online tool that enables quick and easy filtering by performance criteria. It provides system specific information downloads including BIM (Revit) objects. Go to [gyproc.ie](http://gyproc.ie)

<sup>1</sup> Based on a limiting deflection of L/240 at 200 Pa.

<sup>2</sup> Sound insulation performance for partitions finished using jointing or plaster skim.

<sup>3</sup> Sound insulation performance for partitions finished with a 2mm skim finish of Gyproc Finish Plasters.

**NB** The fire resistance and sound insulation performances are for imperforate partitions, but incorporating deflection heads, with all joints taped and filled or skimmed according to Gyproc's recommendations. The quoted performances are achieved only if Gyproc and Isover components are used throughout, and the Company's fixing recommendations are strictly observed. Any variation in the specifications should be checked with Gyproc.

**NB** Gypframe Deep Flange Floor & Ceiling Channel or Gypframe Extra Deep Flange Floor & Ceiling Channel should be used at base and at head (subject to deflection criteria).

## GypWall robust performance (continued)

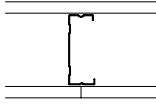
### 92mm Gypframe 'C' Studs - single layer board linings

For details of when to specify fire resistance using EN  
 ▶ Refer to C02. S01. P05



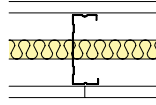
Table 4a — Solutions to satisfy the requirements of BS EN 1364-1: 1999

①



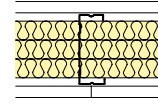
One layer of board each side of Gypframe 92 S 50 'C' Studs at 600mm centres. Linings as in table.

②



One layer of board each side of Gypframe 92 S 50 'C' Studs at 600mm centres. 25mm Isover Acoustic Roll in the cavity. Linings as in table.

③



One layer of board each side of Gypframe 92 S 50 'C' Studs at 600mm centres. 3 x 25mm Isover Acoustic Roll in the cavity. Linings as in table.

Detail	Partition thickness mm	Board type	Lining thickness mm	Max. partition height <sup>1</sup> mm	Sound insulation $R_w$ dB		Duty rating	Approx. weight kg/m <sup>2</sup>	System reference	
					Any finish <sup>2</sup>	Skim only <sup>3</sup>			Any finish <sup>2</sup>	Skim only <sup>3</sup>
<b>60 minutes fire resistance</b> (EN)										
①	124	Gyproc DuraLine	1 x 15	4000	45	46	Severe	29	A206257	A206257S
②	124	Gyproc DuraLine	1 x 15	4000	48 <sup>4</sup>	49 <sup>4</sup>	Severe	30	A206258	A206258S
③	124	Gyproc DuraLine	1 x 15	4000	52	53	Severe	30	Q606057	Q606057S

▶ For further assistance in choosing the right solution for your project, try our System Selector; an online tool that enables quick and easy filtering by performance criteria. It provides system specific information downloads including BIM (Revit) objects. Go to [gyproc.ie](http://gyproc.ie)

<sup>1</sup> The maximum heights quoted are limited by the fire state field of application or by limiting deflection of L/240 at 200 Pa, whichever is the more onerous.

<sup>2</sup> Sound insulation performance for partitions finished using jointing or plaster skim.

<sup>3</sup> Sound insulation performance for partitions finished with a 2mm skim finish of Gyproc Finish Plasters.

<sup>4</sup> Increasing insulation to 50mm Isover Acoustic Roll will not improve this system performance.

**(NB)** The fire resistance and sound insulation performances are for imperforate partitions, but incorporating deflection heads, with all joints taped and filled or skimmed according to Gyproc's recommendations. The quoted performances are achieved only if Gyproc and Isover components are used throughout, and the Company's fixing recommendations are strictly observed. Any variation in the specifications should be checked with Gyproc.

**(NB)** Gypframe Deep Flange Floor & Ceiling Channel or Gypframe Extra Deep Flange Floor & Ceiling Channel should be used at base and at head (subject to deflection criteria).

## GypWall robust performance (continued)

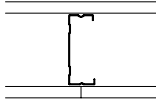
### 92mm Gypframe 'C' Studs - single layer board linings

For details of when to specify fire resistance using BS  
 ▶ Refer to C02. S01. P05



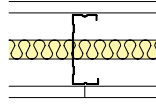
Table 4b — Solutions to satisfy requirements of BS 476: Part 22: 1987

①



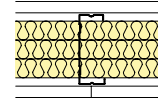
One layer of board each side of Gypframe 92 S 50 'C' Studs at 600mm centres. Linings as in table.

②



One layer of board each side of Gypframe 92 S 50 'C' Studs at 600mm centres. 25mm Isover Acoustic Roll in the cavity. Linings as in table.

③



One layer of board each side of Gypframe 92 S 50 'C' Studs at 600mm centres. 3 x 25mm Isover Acoustic Roll in the cavity. Linings as in table.

Detail	Partition thickness mm	Board type	Lining thickness mm	Max. partition height mm	Sound insulation $R_w$ dB		Duty rating	Approx. weight kg/m <sup>2</sup>	System reference	
					Any finish <sup>1</sup>	Skim only <sup>2</sup>			Any finish <sup>1</sup>	Skim only <sup>2</sup>
<b>60 minutes fire resistance</b>										
①	124	Gyproc DuraLine	1 x 15	4000	45	46	Severe	29	A206257	A206257S
②	124	Gyproc DuraLine	1 x 15	4000	48 <sup>3</sup>	49 <sup>3</sup>	Severe	30	A206258	A206258S
③	124	Gyproc DuraLine	1 x 15	4000	52	53	Severe	30	Q606057	Q606057S

▶ For further assistance in choosing the right solution for your project, try our System Selector; an online tool that enables quick and easy filtering by performance criteria. It provides system specific information downloads including BIM (Revit) objects. Go to [gyproc.ie](http://gyproc.ie)

<sup>1</sup> Sound insulation performance for partitions finished using jointing or plaster skim.

<sup>2</sup> Sound insulation performance for partitions finished with a 2mm skim finish of Gyproc Finish Plasters.

<sup>3</sup> Increasing insulation to 50mm Isover Acoustic Roll will not improve this system performance.

**NB** The fire resistance and sound insulation performances are for imperforate partitions, but incorporating deflection heads, with all joints taped and filled or skimmed according to Gyproc's recommendations. The quoted performances are achieved only if Gyproc and Isover components are used throughout, and the Company's fixing recommendations are strictly observed. Any variation in the specifications should be checked with Gyproc.

**NB** Gypframe Deep Flange Floor & Ceiling Channel or Gypframe Extra Deep Flange Floor & Ceiling Channel should be used at base and at head (subject to deflection criteria).

## GypWall robust performance (continued)

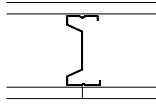
### 92mm Gypframe AcouStuds - single layer board linings

For details of when to specify fire resistance using EN  
 ▶ Refer to C02. S01. P05



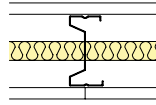
Table 5a — Solutions to satisfy the requirements of BS EN 1364-1: 1999

①



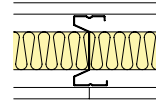
One layer of board each side of 92mm Gypframe AcouStuds at 600mm centres. Linings as in table.

②



One layer of board each side of 92mm Gypframe AcouStuds at 600mm centres. 25mm Isover Acoustic Roll in the cavity. Linings as in table.

③



One layer of board each side of 92mm Gypframe AcouStuds at 600mm centres. 50mm Isover Acoustic Roll in the cavity. Linings as in table.

Detail	Partition thickness mm	Board type	Lining thickness mm	Max. partition height <sup>1</sup> mm	Sound insulation $R_w$ dB		Duty rating	Approx. weight kg/m <sup>2</sup>	System reference	
					Any finish <sup>2</sup>	Skim only <sup>3</sup>			Any finish <sup>2</sup>	Skim only <sup>3</sup>
<b>60 minutes fire resistance</b>										
①	124	Gyproc DuraLine	1 x 15	4000	45	46	Severe	29	A206A277	A206A277S
②	124	Gyproc DuraLine	1 x 15	4000	50	51	Severe	30	A206A278	A206A278S
③	124	Gyproc DuraLine	1 x 15	4000	52	53	Severe	30	A206A279	A206A279S

▶ For further assistance in choosing the right solution for your project, try our System Selector; an online tool that enables quick and easy filtering by performance criteria. It provides system specific information downloads including BIM (Revit) objects. Go to [gyproc.ie](http://gyproc.ie)

<sup>1</sup> The maximum heights quoted are limited by the fire state field of application or by limiting deflection of L/240 at 200 Pa, whichever is the more onerous.

<sup>2</sup> Sound insulation performance for partitions finished using jointing or plaster skim.

<sup>3</sup> Sound insulation performance for partitions finished with a 2mm skim finish of Gyproc Finish Plasters.

**NB** The fire resistance and sound insulation performances are for imperforate partitions, but incorporating deflection heads, with all joints taped and filled or skimmed according to Gyproc's recommendations. The quoted performances are achieved only if Gyproc and Isover components are used throughout, and the Company's fixing recommendations are strictly observed. Any variation in the specifications should be checked with Gyproc.

**NB** Gypframe Deep Flange Floor & Ceiling Channel or Gypframe Extra Deep Flange Floor & Ceiling Channel should be used at base and at head (subject to deflection criteria).

## GypWall robust performance (continued)

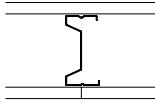
### 92mm Gypframe AcouStuds - single layer board linings

For details of when to specify fire resistance using BS  
 ▶ Refer to C02. S01. P05



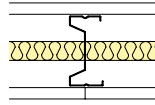
Table 5b — Solutions to satisfy requirements of BS 476: Part 22: 1987

①



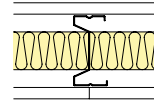
One layer of board each side of 92mm Gypframe AcouStuds at 600mm centres. Linings as in table.

②



One layer of board each side of 92mm Gypframe AcouStuds at 600mm centres. 25mm Isover Acoustic Roll in the cavity. Linings as in table.

③



One layer of board each side of 92mm Gypframe AcouStuds at 600mm centres. 50mm Isover Acoustic Roll in the cavity. Linings as in table.

Detail	Partition thickness mm	Board type	Lining thickness mm	Max. partition height mm	Sound insulation $R_w$ dB		Duty rating	Approx. weight kg/m <sup>2</sup>	System reference	
					Any finish <sup>1</sup>	Skim only <sup>2</sup>			Any finish <sup>1</sup>	Skim only <sup>2</sup>
<b>60 minutes fire resistance</b>										
①	124	Gyproc DuraLine	1 x 15	4000	45	46	Severe	29	A206A277	A206A277S
②	124	Gyproc DuraLine	1 x 15	4000	50	51	Severe	30	A206A278	A206A278S
③	124	Gyproc DuraLine	1 x 15	4000	52	53	Severe	30	A206A279	A206A279S

▶ For further assistance in choosing the right solution for your project, try our System Selector; an online tool that enables quick and easy filtering by performance criteria. It provides system specific information downloads including BIM (Revit) objects. Go to [gyproc.ie](http://gyproc.ie)

<sup>1</sup> Sound insulation performance for partitions finished using jointing or plaster skim.

<sup>2</sup> Sound insulation performance for partitions finished with a 2mm skim finish of Gyproc Finish Plasters.

**NB** The fire resistance and sound insulation performances are for imperforate partitions, but incorporating deflection heads, with all joints taped and filled or skimmed according to Gyproc's recommendations. The quoted performances are achieved only if Gyproc and Isover components are used throughout, and the Company's fixing recommendations are strictly observed. Any variation in the specifications should be checked with Gyproc.

**NB** Gypframe Deep Flange Floor & Ceiling Channel or Gypframe Extra Deep Flange Floor & Ceiling Channel should be used at base and at head (subject to deflection criteria).

## GypWall robust performance (continued)

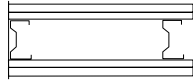
### 70mm Gypframe AcouStuds - double layer board linings

For details of when to specify fire resistance using EN  
 ► Refer to C02. S01. P05



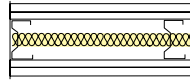
Table 6a — Solutions to satisfy the requirements of BS EN 1364-1: 1999

①



One inner layer and one outer layer of board each side of Gypframe 70 AS 50 AcouStuds at 600mm centres. Linings as in table.

②



One inner layer and one outer layer of board each side of Gypframe 70 AS 50 AcouStuds at 600mm centres. 25mm Isover Acoustic Roll in the cavity. Linings as in table.

Detail	Partition thickness mm	Inner board type mm	Outer board type mm	Max. partition height <sup>1</sup> mm	Sound insulation $R_w$ dB		Duty rating	Approx. weight kg/m <sup>2</sup>	System reference	
					Any finish <sup>2</sup>	Skim only <sup>3</sup>			Any finish <sup>2</sup>	Skim only <sup>3</sup>
<b>90 minutes fire resistance</b> (EN)										
②	127	Gyproc SoundBloc 1 x 12.5	Gyproc DuraLine 1 x 15	4000	57	58	Severe	52	Q606A063	Q606A063S
<b>120 minutes fire resistance</b> (EN)										
①	127	Gyproc SoundBloc 1 x 12.5	Gyproc DuraLine 1 x 15	4000	53	-	Severe	51	Q606A062	-
②	127	Gyproc SoundBloc 1 x 12.5	Gyproc DuraLine 1 x 15	3000	57	58	Severe	52	Q606A063	Q606A063S

► For further assistance in choosing the right solution for your project, try our System Selector; an online tool that enables quick and easy filtering by performance criteria. It provides system specific information downloads including BIM (Revit) objects. Go to [gyproc.ie](http://gyproc.ie)

<sup>1</sup>The maximum heights quoted are limited by the fire state field of application or by limiting deflection of L/240 at 200 Pa, whichever is the more onerous.

<sup>2</sup>Sound insulation performance for partitions finished using jointing or plaster skim.

<sup>3</sup>Sound insulation performance for partitions finished with a 2mm skim finish of Gyproc Finish Plasters.

**(NB)** The fire resistance and sound insulation performances are for imperforate partitions, but incorporating deflection heads, with all joints taped and filled or skimmed according to Gyproc's recommendations. The quoted performances are achieved only if Gyproc and Isover components are used throughout, and the Company's fixing recommendations are strictly observed. Any variation in the specifications should be checked with Gyproc.

**(NB)** Gypframe Deep Flange Floor & Ceiling Channel or Gypframe Extra Deep Flange Floor & Ceiling Channel should be used at base and at head (subject to deflection criteria).

## GypWall robust performance (continued)

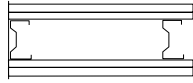
### 70mm Gypframe AcouStuds - double layer board linings

For details of when to specify fire resistance using BS  
 ▶ Refer to C02. S01. P05



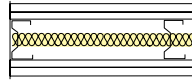
Table 6b — Solutions to satisfy requirements of BS 476: Part 22: 1987

①



One inner layer and one outer layer of board each side of Gypframe 70 AS 50 AcouStuds at 600mm centres. Linings as in table.

②



One inner layer and one outer layer of board each side of Gypframe 70 AS 50 AcouStuds at 600mm centres. 25mm Isover Acoustic Roll in the cavity. Linings as in table.

Detail	Partition thickness mm	Inner board type mm	Outer board type mm	Max. partition height mm	Sound insulation $R_w$ dB		Duty rating	Approx. weight kg/m <sup>2</sup>	System reference	
					Any finish <sup>1</sup>	Skim only <sup>2</sup>			Any finish <sup>1</sup>	Skim only <sup>2</sup>
<b>120 minutes fire resistance (BS)</b>										
①	127	Gyproc SoundBloc 1 x 12.5	Gyproc DuraLine 1 x 15	4000	53	-	Severe	51	Q606A062	-
②	127	Gyproc SoundBloc 1 x 12.5	Gyproc DuraLine 1 x 15	3000	57	58	Severe	52	Q606A063	Q606A063S
①	132	Gyproc SoundBloc 1 x 15	Gyproc DuraLine 1 x 15	4000	53	54	Severe	55	Q606A064	Q606A064S

▶ For further assistance in choosing the right solution for your project, try our System Selector; an online tool that enables quick and easy filtering by performance criteria. It provides system specific information downloads including BIM (Revit) objects. Go to [gyproc.ie](http://gyproc.ie)

<sup>1</sup> Sound insulation performance for partitions finished using jointing or plaster skim.

<sup>2</sup> Sound insulation performance for partitions finished with a 2mm skim finish of Gyproc Finish Plasters.

**NB** The fire resistance and sound insulation performances are for imperforate partitions, but incorporating deflection heads, with all joints taped and filled or skimmed according to Gyproc's recommendations. The quoted performances are achieved only if Gyproc and Isover components are used throughout, and the Company's fixing recommendations are strictly observed. Any variation in the specifications should be checked with Gyproc.

**NB** Gypframe Deep Flange Floor & Ceiling Channel or Gypframe Extra Deep Flange Floor & Ceiling Channel should be used at base and at head (subject to deflection criteria).

# GypWall ROBUST design

## Building design

Whilst our GypWall partitions are non-loadbearing, they are able to provide resistance to levels of horizontal uniformly distributed loads in accordance with BS 6399.

► Refer to C02. S01. P37 – Robustness.

## Planning – key factors

GypWall ROBUST comprises Gypframe 'C' Studs installed at 600mm centres within Gypframe Deep Flange Floor & Ceiling Channels. The position of services and heavy fixtures should be pre-determined and their installation planned into the frame erection stage.

## Fixing floor and ceiling channels

Gypframe Deep Flange Floor & Ceiling Channels must be securely fixed with a row of fixings at 600mm maximum centres. For 94mm channels and above, two rows of staggered fixings are required, each row at 600mm centres and each fixing 25mm in from the flange. If the floor is uneven, a 38mm thick timber sole plate equal to the width of the channel should be used.

If the concrete or screeded floor is new, consideration should be given to the installation of a damp-proof membrane between the floor surface and the channel or sole plate.



## Important information

Gypframe Deep Flange Floor & Ceiling Channels (DC) must be used with all GypWall ROBUST systems.

► Refer to GypWall ROBUST – construction details 1 and 2.

## Splicing

To extend studs, overlap by 600mm (minimum). Fix together using Gyproc Wafer Head Drywall Screws or steel pop rivets (two to each flange).

► Refer to Partitions introduction C04. S01. P110 – construction detail 1.

## Partition to structural steelwork junctions

When designing the layout of rooms requiring separation by sound insulating walls abutting structural steelwork, consideration should be given to the potential loss of sound insulation performance through the steelwork.

► Refer to C02. S01. P21 – Building acoustics.

## Door openings

The designer should consider the thickness tolerances of the partition types in relation to the proposed door frame detail. To satisfy BS 5234: Part 2 requirements for Heavy and Severe Duty Rating partitions, door framing should be specified. The door manufacturer should also be consulted in relation to the door detail.

► Refer to Partitions introduction C04. S01. P119 – construction details 26 and 27.



## Important information

Particular care must be taken in selecting the correct length of Gyproc Drywall Screws for fixing Gyproc DuraLine to Gypframe AcuStuds to ensure that they do not penetrate the web of the stud. Doing so would create a physical bridge that would lead to a downgrade in sound insulation performance.

## Framing surround for openings

Where services such as horizontal ducts, fire dampers and access panels are required to penetrate the wall, their position should be pre-determined in order that a framed opening can be provided. The openings should be constructed using established metal stud procedures.

► Refer to Partitions introduction C04. S01. P121 – construction details 28-31.

## Cavity fire barriers

Where required to maintain fire performance, suitable fire stopping (by others) should be installed full filled within the partition cavity to form a suitable closure.

► Refer to C06. S06. P422 – Cavity fire barriers.

## Control joints

Control joints may be required in the partition to relieve stresses induced by expansion and contraction of the structure. They should coincide with movement joints within the surrounding structure.

## Deflection heads

Partition head deflection designs may be necessary to accommodate deflections in the supporting floor. Deflection heads may also be required to the underside of roof structures subjected to positive and negative pressures.

To minimise the loss of acoustic performance:

► Refer to C02. S01. P21 – Building acoustics.

For deflection head design:

► Refer to Partitions introduction C04. S01. P116 – construction details 15 - 22.

### Services

#### Penetrations

Penetrations of fire-resistant or sound-insulating constructions for services need careful consideration to ensure that the performance of the element is not downgraded. Consideration also needs to be given to the services themselves so they do not act as the mechanism of fire spread or sound transmission.

▶ Refer to C02. S01. P41 – Service installations.

#### Electrical

The installation of electrical services should be carried out in accordance with *BS 7671*. The cut-outs in the studs can be used for routing electrical and other small services.

▶ Refer to Partitions introduction C04. S01. P110 – construction detail 2.

Switch boxes and socket outlets can be supported from Gypframe 99 FC 50 Fixing Channel fixed horizontally between studs, or a high performance socket box detail where higher acoustic performance is required.

Where Gypframe AcouStuds are used, services are routed through 50mm x 28mm 'H' shaped push-outs, at the same centres as shown for conventional cut-outs.

▶ Refer to Partitions introduction C04. S01. P110 – construction detail 2a.

Cables should be protected by conduit, or other suitable precautions taken to prevent abrasion when they pass through the metal frame.



### Handy hint

Where access is limited to one side at the head, e.g. M+E cages already installed in corridors.

▶ Refer to C05. S02. P289 – **ShaftWall**.

#### Independent support

When designing for the installation of services such as fire dampers and associated ductwork through a **GypWall** partition, consideration should be given to the size and weight of the damper - this will determine whether it can be supported directly from the partition or needs to be independently supported from the structure.

▶ Refer to Partitions introduction C04. S01. P122 – construction details 29-31.

### Fixtures

Lightweight fixtures can be made directly to the partition linings. Medium weight fixtures can be made to Gypframe 99 FC 50 Fixing Channel. Heavyweight fixtures (to *BS 5234*), such as wash basins and wall cupboards, can be fixed using plywood secured with Gypframe Service Support Plates.

▶ Refer to C02. S01. P41 – Service installations.

### Access for maintenance

Gyproc Profilex Access Panels are available to provide access for maintenance. Access panels must be fully compatible with drywall construction and match the fire rating of the partition.

▶ Refer to the Gyproc Technical Department for further information.

### Board finishing

▶ Refer to C08. S01. P483 – Finishes.

### Tiling

Tiles can be applied to the surface of lightweight partition systems.

▶ Refer to C08. S04. P498 – Tiling.

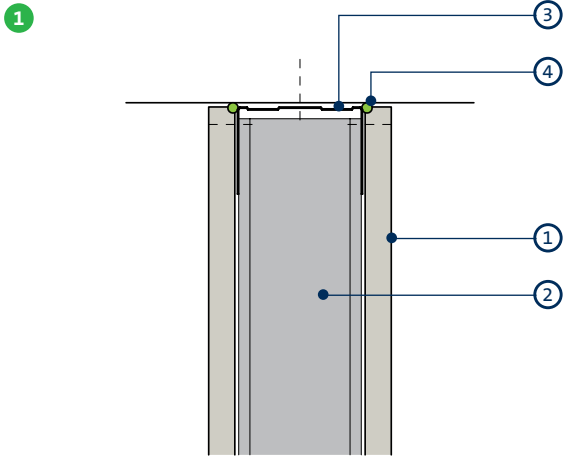
### Construction details

For standard **GypWall** construction details

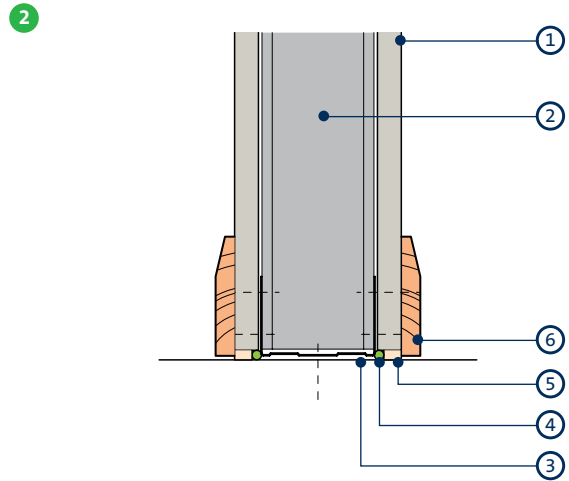
▶ Refer to Partitions introduction C04. S01. P110 – construction details.

For **GypWall robust** system specific construction details refer to the following pages.

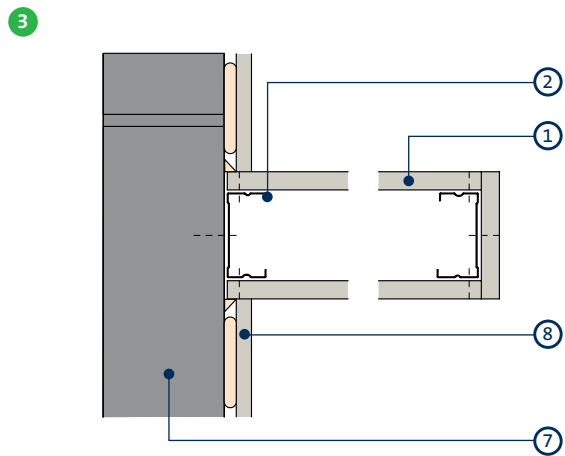
# GypWall ROBUST construction details



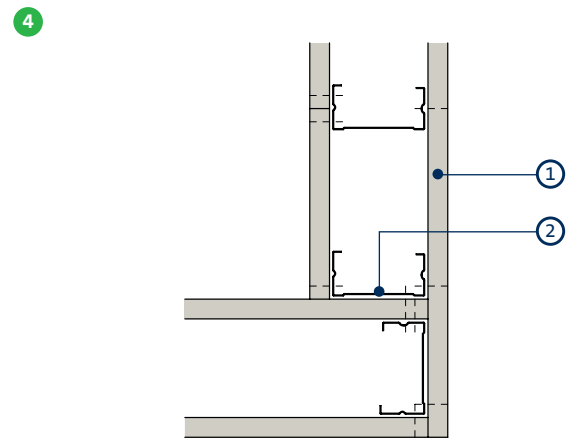
Head



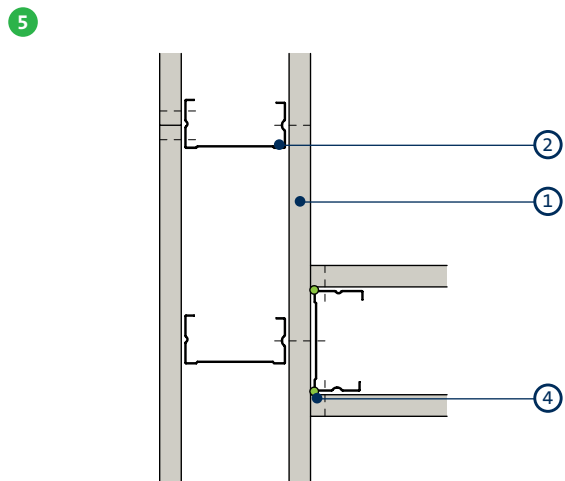
Base



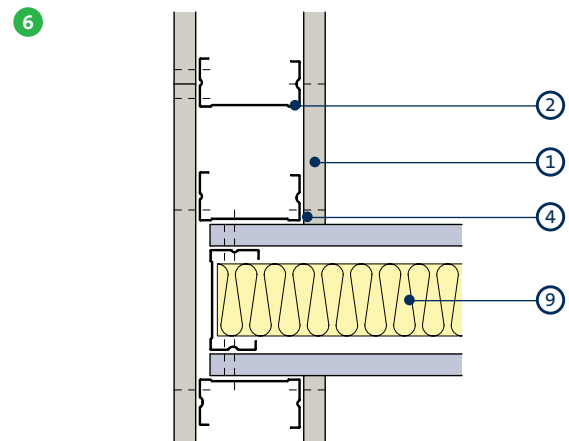
Junction with masonry and stop end



Corner



'T' junction



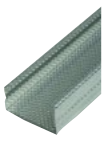
'T' Junction when partition with higher acoustic performance abuts a partition with lower acoustic performance. Acoustic principles only - detail may not be suitable for all solutions

- 1 Gyproc Duraline
- 2 Gypframe 'C' Stud
- 3 Gypframe Deep Flange Floor & Ceiling Channel
- 4 Gyproc Sealant
- 5 Bulk fill with Gyproc jointing materials (where gap exceeds 5mm)

- 6 Skirting
- 7 Internal masonry
- 8 **Drilyner** wall lining system
- 9 Isover Acoustic Roll

# GypWall robust system components

## Gypframe metal components



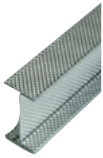
### Gypframe 'C' Studs (70 S 60, 92 S 60)

Vertical stud providing acoustic and structural performances designed to receive fixing of board to both sides.



### Gypframe GFS1 Fixing Strap

Used to support horizontal board joints and within deflection heads.



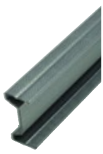
### Gypframe 'I' Studs (70 I 50, 70 I 70, 92 I 90)

Enhanced strength stud that allows for lining height, without increasing lining width. Designed to receive fixing of board to both sides.



### Gypframe GFT1 Fixing T

Used to support horizontal board joints.



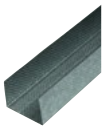
### Gypframe AcouStud (70 AS 50, 92 AS 50)

Vertical stud providing enhanced acoustic and structural performances designed to receive fixing of board to both sides.



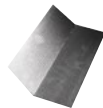
### Gypframe GA5 Internal Fixing Angle

Steel angle providing framing stability and board support.



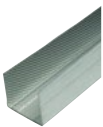
### Gypframe Deep Flange Floor & Ceiling Channels (72 DC 60, 94 DC 60)

Floor and ceiling channels with deep flanges for retaining the Gypframe studs at floor and ceiling junctions for partitions 4200mm to 8000mm high. Also used around openings and in deflection heads (maximum 30mm deflection).



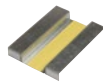
### Gypframe GA6 Splayed Angle

Steel angle providing framing stability and board support.



### Gypframe Extra Deep Flange Floor & Ceiling Channels (72 EDC 80, 94 EDC 70)

Floor and ceiling channels with extra deep flanges for retaining the Gypframe studs at floor and ceiling junctions for partitions over 8000mm high. Also used around openings and in deflection heads (maximum 50mm deflection).



### Gypframe Service Support Plate

For installation of 18mm plywood within a partition cavity to support medium to heavyweight fixtures.



### Gypframe 99 FC 50 Fixing Channel

A versatile metal fixing channel used to support medium weight fixtures on walls.

## Board products



### Gyproc DuraLine<sup>1</sup>

Gypsum plasterboard with fire resistant additives and a high density core for enhanced sound insulation and impact resistance performance.



### Glasroc F FIRECASE

Non-combustible glass-reinforced gypsum board. Used to form deflection head.



### Gyproc SoundBloc<sup>1</sup>

Gypsum plasterboard with a high density core for enhanced sound insulation performance.



### Gyproc CoreBoard

Gypsum plasterboard with fire and moisture resistant additives. Used to form deflection head.

<sup>1</sup> Also available in a Moisture Resistant (MR) version. MR boards are specified in intermittent wet use areas.

## GypWall robust system components (continued)

### Fixing products



#### Gyproc Drywall Screws

Corrosion resistant self-tapping steel screws for fixing board-to-timber and board-to-metal framing less than 0.8mm thick ('I' Studs less than 0.6mm thick).



#### Gyproc Jack-Point Screws

Corrosion resistant self-tapping steel screws for fixing board to metal framing 0.8mm thick and greater ('I' stud 0.6mm thick and greater).



#### Gyproc Collated Drywall Screws

Corrosion resistant self-tapping steel screws for fixing board-to-timber and board-to-metal framing less than 0.8mm thick ('I' Studs less than 0.6mm thick).



#### Gyproc Wafer Head Jack-Point Screws

Corrosion resistant self-tapping steel screws for fixing metal to metal framing 0.8mm thick and greater ('I' Studs 0.8mm thick and greater).



#### Gyproc Wafer Head Drywall Screws

Corrosion resistant self-tapping steel screws for fixing metal to metal framing less than 0.8mm thick ('I' Studs less than 0.6mm thick).

### Plasterboard accessories



#### Gyproc Jointing Material

Jointing compounds, ready mixes and adhesives for reinforcement and finishing of board joints.



#### Gyproc Sealant

Used to seal air paths for optimum sound insulation.



#### Gyproc FireStrip

A soft extruded linear intumescent gap sealer to maintain fire resistance located directly to the underside of the soffit when forming a deflection head.



#### Gyproc Paper Joint Tape

A paper tape designed for reinforcement of flat joints or internal angles.



#### Gyproc Control Joint

To accommodate structural movement of up to 7mm.



#### Gyproc Drywall Primer

Used to prepare for painting. Tub contents 10 litre.

### Finishing products



#### Gyproc Skimcoat

To provide a plaster skim finish on most common backgrounds including undercoat plasters and plasterboard. Can provide enhanced acoustic performance.



#### Gyproc Carlite Finish

To provide a plaster skim finish on most common backgrounds including undercoat plasters and plasterboard. Can provide enhanced acoustic performance.



#### Gyproc Carlite Ultra Finish

Offers all the benefits of Gyproc Skimcoat and Gyproc Carlite Finish with a reduced set time of 90-120 mins, making it ideal for smaller jobs



#### Gyproc Magnetic Plaster

To provide a plaster skim finish that provides an attraction to magnets used to finish a wide range of backgrounds, including undercoat plasters and plasterboard.

## GypWall robust system components (continued)

### Finishing products

---



#### Plaster accessories

Designed for the reinforcement and finishing of board joints before plaster skimming.

---

### Insulation products

---



#### Isover Acoustic Roll

Glass mineral wool for enhanced acoustic performance.

---



#### Isover Modular Roll

Glass mineral wool for enhanced acoustic performance.

---



#### Isover Acoustic Slab

Glass mineral wool to achieve acoustic performance.

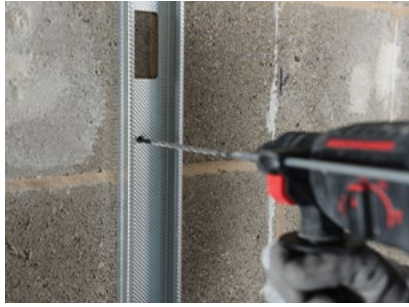
---

# GypWall ROBUST installation overview

This is intended to be a basic description of how the system is built.



Gypframe Deep Flange or Extra Deep Flange Floor & Ceiling Channels are suitably fixed to the floor and soffit.



Gypframe Studs are suitably fixed to abutments.



The perimeter of the partition is then sealed on both sides with Gyproc Sealant.



Gypframe Studs are then friction fitted into the Gypframe Floor & Ceiling Channels at the required centres.



Door openings are constructed to the Heavy and Severe door detail.



M&E services can be located within the partition cavity.



Isover insulation can also be added to the partition cavity for increased acoustic performance.



Gyproc DuraLine (and Gyproc SoundBloc inner layer if required) plasterboards are then fixed to the Gypframe framework with Gyproc Drywall Screws.



## Additional information

For full installation details, refer to the **Gyproc Installation Guide**, available to download from [gyproc.ie](http://gyproc.ie)



# GypWall EXTREME

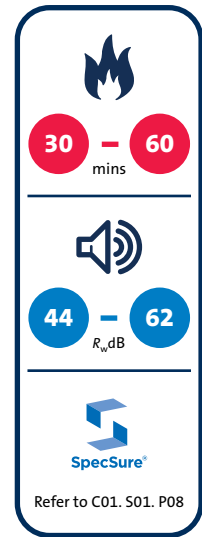
Ultimate impact and abrasion resistant partition system



# GypWall EXTREME

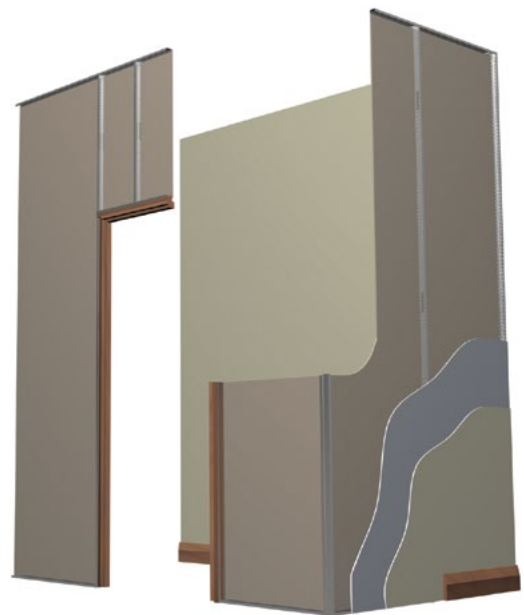
**GypWall EXTREME** is our ultimate impact resistant partition, incorporating Rigidur reinforced gypsum board with its extremely high levels of impact and abrasion resistance, in combination with high-strength Gypframe components, results in a range of partition systems with durability that will exceed expectations.

The **GypWall EXTREME** family of partitions have been tested to the extreme, comfortably surpassing all requirements of a full Severe Duty Rating in accordance with *BS 5234: Part 2: 1992*.



## Key benefits

- Provides performance beyond a Severe Duty Rating from a lightweight, narrow-footprint solution
- Heavy fixtures can be secured to a single layer without the need for additional pattrassing
- Reduced maintenance cycles due to a highly impact and scratch resistant board surface
- Fully compatible with other Gyproc systems, meaning **GypWall EXTREME** can be specified in areas of the building that really need it



# GypWall EXTREME performance

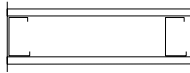
## 70mm Gypframe 'C' Stud and Gypframe AcouStud

For details of when to specify fire resistance using EN  
 ▶ Refer to C02. S01. P18



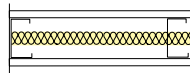
Table 1a — Solutions to satisfy the requirements of BS EN 1364-1: 1999

①



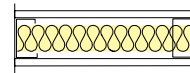
One layer of board each side of Gypframe 70 S 60 'C' Studs at 600mm centres. Linings as in table.

②



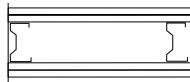
One layer of board each side of Gypframe 70 S 60 'C' Studs at 600mm centres. 25mm Isover Acoustic Roll in the cavity. Linings as in table.

③



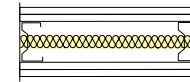
One layer of board each side of Gypframe 70 S 60 'C' Studs at 600mm centres. 50mm Isover Acoustic Roll in the cavity. Linings as in table.

④



Two layers of board each side of Gypframe 70 AS 50 AcouStuds at 600mm centres. Linings as in table.

⑤



Two layers of board each side of Gypframe 70 AS 50 AcouStuds at 600mm centres. 25mm Isover Acoustic Roll in the cavity. Linings as in table.

Detail	Partition thickness mm	Inner board type mm	Outer board type mm	Max. partition height <sup>1</sup> mm	Sound insulation $R_w$ dB	Duty rating	Approx. weight kg/m <sup>2</sup>	System reference
<b>30 minutes fire resistance</b>								
①	97	Rigidur 12.5	-	3800	44	Severe <sup>2</sup>	30	X606009
②	97	Rigidur 12.5	-	3800	47	Severe <sup>2</sup>	30	X606010
③	97	Rigidur 12.5	-	3800	49	Severe <sup>2</sup>	30	X606011
①	102	Rigidur 15	-	4000	45	Severe <sup>2</sup>	36	X606001
②	102	Rigidur 15	-	4000	51	Severe <sup>2</sup>	36	X606002
③	102	Rigidur 15	-	4000	52	Severe <sup>2</sup>	36	X606003
<b>60 minutes fire resistance</b>								
④	122	Gyproc SoundBloc 12.5	Rigidur 12.5	4000	54	Severe <sup>2</sup>	52	X606A006
④	127	Gyproc WallBoard 15	Rigidur 12.5	4000	54	Severe <sup>2</sup>	52	X606A005
⑤	127	Gyproc SoundBloc 15	Rigidur 12.5	4000	58	Severe <sup>2</sup>	56	X606A007

▶ For further assistance in choosing the right solution for your project, try our System Selector; an online tool that enables quick and easy filtering by performance criteria. It provides system specific information downloads including BIM (Revit) objects. Go to [gyproc.ie](http://gyproc.ie)

<sup>1</sup> The maximum heights quoted are limited by the fire state field of application or by limiting deflection of L/240 at 200 Pa, whichever is the more onerous.

<sup>2</sup> The resistance to impact of Rigidur is higher than the most severe criteria set out in BS 5234. Gyproc has conducted a number of additional structural performance and durability tests beyond Severe Duty to better reflect actual use in high traffic areas. Search for substantiation report on [gyproc.ie](http://gyproc.ie) and type in the reference number.

**NB** The fire resistance and sound insulation performances are for imperforate partitions, walls and ceilings incorporating boards with all joints taped and filled, or skimmed according to Gyproc's recommendations. The quoted performances are achieved only if Gyproc and Isover components are used throughout, and the Company's fixing recommendations are strictly observed. Any variation in the specifications should be checked with Gyproc.

**NB** Gypframe Deep Flange Floor & Ceiling Channel or Gypframe Extra Deep Flange Floor & Ceiling Channel should be used at base and at head (subject to deflection criteria).

# GypWall EXTREME performance (continued)

## 70mm Gypframe 'C' Stud and Gypframe AcouStud

For details of when to specify fire resistance using BS  
 ▶ Refer to C02. S01. P18



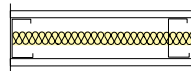
Table 1b — Solutions to satisfy requirements of BS 476: Part 22: 1987

①



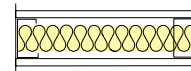
One layer of board each side of Gypframe 70 S 60 'C' Studs at 600mm centres. Linings as in table.

②



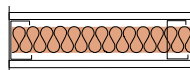
One layer of board each side of Gypframe 70 S 60 'C' Studs at 600mm centres. 25mm Isover Acoustic Roll in the cavity. Linings as in table.

③



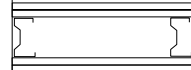
One layer of board each side of Gypframe 70 S 60 'C' Studs at 600mm centres. 50mm Isover Acoustic Roll in the cavity. Linings as in table.

④



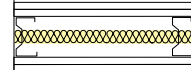
One layer of board each side of Gypframe 70 S 60 'C' Studs at 600mm centres. 60mm Isover ULTIMATE™ Piano Plus in the cavity. Linings as in table.

⑤



Two layers of board each side of Gypframe 70 AS 50 AcouStuds at 600mm centres. Linings as in table.

⑥



Two layers of board each side of Gypframe 70 AS 50 AcouStuds at 600mm centres. 25mm Isover Acoustic Roll in the cavity. Linings as in table.

Detail	Partition thickness mm	Inner board type mm	Outer board type mm	Max. partition height <sup>1</sup> mm	Sound insulation $R_w$ dB	Duty rating	Approx. weight kg/m <sup>2</sup>	System reference
<b>30 minutes fire resistance</b>								
①	97	Rigidur 12.5	-	3800	44	Severe <sup>2</sup>	30	X606009
②	97	Rigidur 12.5	-	3800	47	Severe <sup>2</sup>	30	X606010
③	97	Rigidur 12.5	-	3800	49	Severe <sup>2</sup>	30	X606011
①	102	Rigidur 15	-	4000	45	Severe <sup>2</sup>	36	X606001
②	102	Rigidur 15	-	4000	51	Severe <sup>2</sup>	36	X606002
③	102	Rigidur 15	-	4000	52	Severe <sup>2</sup>	36	X606003
<b>60 minutes fire resistance</b>								
④	97	Rigidur 12.5	-	3800	49	Severe <sup>2</sup>	30	X606012
④	102	Rigidur 15	-	4000	51	Severe <sup>2</sup>	36	X606004
⑤	122	Gyproc SoundBloc 12.5	Rigidur 12.5	4700	54	Severe <sup>2</sup>	52	X606A006
⑤	127	Gyproc WallBoard 15	Rigidur 12.5	4700	54	Severe <sup>2</sup>	52	X606A005
⑥	127	Gyproc SoundBloc 15	Rigidur 12.5	4700	58	Severe <sup>2</sup>	56	X606A007

▶ For further assistance in choosing the right solution for your project, try our System Selector; an online tool that enables quick and easy filtering by performance criteria. It provides system specific information downloads including BIM (Revit) objects. Go to [gyproc.ie](http://gyproc.ie)

<sup>1</sup> Based on a limiting deflection of L/240 at 200 Pa.

<sup>2</sup> The resistance to impact of Rigidur is higher than the most severe criteria set out in BS 5234. Gyproc has conducted a number of additional structural performance and durability tests beyond Severe Duty to better reflect actual use in high traffic areas. Search for substantiation report on [gyproc.ie](http://gyproc.ie) and type in the reference number.

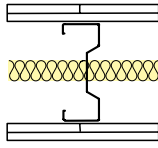
**NB** The fire resistance and sound insulation performances are for imperforate partitions, walls and ceilings incorporating boards with all joints taped and filled, or skimmed according to Gyproc's recommendations. The quoted performances are achieved only if Gyproc and Isover components are used throughout, and the Company's fixing recommendations are strictly observed. Any variation in the specifications should be checked with Gyproc.

**NB** Gypframe Deep Flange Floor & Ceiling Channel or Gypframe Extra Deep Flange Floor & Ceiling Channel should be used at base and at head (subject to deflection criteria).



Table 2a — Solutions to satisfy the requirements of BS EN 1364-1: 1999

①



Two layers of board each side of Gypframe 146 AS 50 AcouStuds at 600mm centres. 25mm Isover Acoustic Roll in the cavity. Linings as in table.

Detail	Partition thickness mm	Inner board type mm	Outer board type mm	Max. partition height <sup>1</sup> mm	Sound insulation $R_w (R_w + C_v)$ dB	Duty rating	Approx. weight kg/m <sup>2</sup>	System reference
<b>60 minutes fire resistance</b> (EN)								
①	203	Gyproc SoundBloc 15	Rigidur 12.5	4000	60 (57)	Severe <sup>2</sup>	56	X606A013

► For further assistance in choosing the right solution for your project, try our System Selector; an online tool that enables quick and easy filtering by performance criteria. It provides system specific information downloads including BIM (Revit) objects. Go to [gyproc.ie](http://gyproc.ie)

<sup>1</sup>The maximum heights quoted are limited by the fire state field of application or by limiting deflection of L/240 at 200 Pa, whichever is the more onerous.

<sup>2</sup>The resistance to impact of Rigidur is higher than the most severe criteria set out in BS 5234. Gyproc has conducted a number of additional structural performance and durability tests beyond Severe Duty to better reflect actual use in high traffic areas. Search for substantiation report on [gyproc.ie](http://gyproc.ie) and type in the reference number.

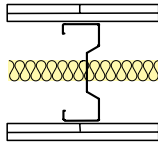
**(NB)** The fire resistance and sound insulation performances are for imperforate partitions, walls and ceilings incorporating boards with all joints taped and filled, or skimmed according to Gyproc’s recommendations. The quoted performances are achieved only if Gyproc and Isover components are used throughout, and the Company’s fixing recommendations are strictly observed. Any variation in the specifications should be checked with Gyproc.

**(NB)** Gypframe Deep Flange Floor & Ceiling Channel or Gypframe Extra Deep Flange Floor & Ceiling Channel should be used at base and at head (subject to deflection criteria).



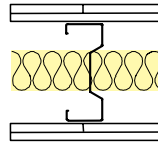
Table 2b — Solutions to satisfy requirements of BS 476: Part 22: 1987

①



Two layers of board each side of Gypframe 146 AS 50 AcouStuds at 600mm centres. 25mm Isover Acoustic Roll in the cavity. Linings as in table.

②



Two layers of board each side of Gypframe 146 AS 50 AcouStuds at 600mm centres. 50mm Isover Acoustic Roll in the cavity. Linings as in table.

Detail	Partition thickness mm	Inner board type mm	Outer board type mm	Max. partition height <sup>1</sup> mm	Sound insulation $R_w (R_w + C_{tr})$ dB	Duty rating	Approx. weight kg/m <sup>2</sup>	System reference
<b>60 minutes fire resistance</b>								
①	203	Gyproc SoundBloc 15	Rigidur 12.5	7800	60 (57)	Severe <sup>2</sup>	56	X606A013
②	203	Gyproc SoundBloc 15	Rigidur 12.5	7800	62 (59)	Severe <sup>2</sup>	56	X606A014

▶ For further assistance in choosing the right solution for your project, try our System Selector; an online tool that enables quick and easy filtering by performance criteria. It provides system specific information downloads including BIM (Revit) objects. Go to [gyproc.ie](http://gyproc.ie)

<sup>1</sup> Based on a limiting deflection of L/240 at 200 Pa.

<sup>2</sup> The resistance to impact of Rigidur is higher than the most severe criteria set out in BS 5234. Gyproc has conducted a number of additional structural performance and durability tests beyond Severe Duty to better reflect actual use in high traffic areas. Search for substantiation report on [gyproc.ie](http://gyproc.ie) and type in the reference number.

**NB** The fire resistance and sound insulation performances are for imperforate partitions, walls and ceilings incorporating boards with all joints taped and filled, or skimmed according to Gyproc's recommendations. The quoted performances are achieved only if Gyproc and Isover components are used throughout, and the Company's fixing recommendations are strictly observed. Any variation in the specifications should be checked with Gyproc.

**NB** Gypframe Deep Flange Floor & Ceiling Channel or Gypframe Extra Deep Flange Floor & Ceiling Channel should be used at base and at head (subject to deflection criteria).

## Building design

Whilst our GypWall partition systems are non-loadbearing, they are able to provide resistance to levels of horizontal uniformly distributed loads.

► Refer to C02. S01. P37 – Robustness.

## Planning – key factors

GypWall EXTREME comprises Gypframe 'C' Studs installed at 600mm centres within Gypframe Deep Flange Floor & Ceiling Channels. The position of services and heavy fixtures should be pre-determined and their installation planned into the frame erection stage.

## Fixing floor and ceiling channels

Gypframe Deep Flange Floor & Ceiling Channels must be securely fixed with a row of fixings at 600mm maximum centres. For 94mm channels and above, two rows of staggered fixings are required, each row at 600mm centres and each fixing 25mm in from the flange. If the floor is uneven, a 38mm thick timber sole plate equal to the width of the channel should be used.

If the concrete or screeded floor is new, consideration should be given to the installation of a damp-proof membrane between the floor surface and the channel or sole plate.

## Splicing

To extend studs, overlap by 600mm (minimum). Fix together using Gyproc Wafer Head Drywall Screws or steel pop rivets (two to each flange).

► Refer to Partitions introduction C04. S01. P110 – construction detail 1.

## Partition to structural steelwork junctions

When designing the layout of rooms requiring separation by sound insulating walls abutting structural steelwork, consideration should be given to the potential loss of sound insulation performance through the steelwork.

► Refer to C02. S01. P21 – Building acoustics.

## Door openings

The designer should consider the thickness tolerances of the partition types in relation to the proposed door frame detail. To satisfy BS 5234 requirements for Heavy and Severe Duty partitions, door framing should be specified as shown in Partitions introduction C04. S01. P119 – construction details 26. The door manufacturer should also be consulted in relation to the door detail.

If a plastered finish is specified, the thickness of the door or glazing frame must allow for the thickness of the plaster finish.

## Cavity fire barriers

Minimum 12.5mm Gyproc plasterboard screw-fixed into the web of perimeter channels or vertical studs will provide a satisfactory closure to flame or smoke.

► Refer to C06. S06. P422 – Cavity fire barriers.

## Control joints

Control joints may be required in the partition to relieve stresses induced by expansion and contraction of the structure. They should coincide with movement joints within the surrounding structure.

► Refer to Partitions introduction C04. S01. P115 – construction detail 12.

## Deflection heads

Partition head deflection designs may be necessary to accommodate deflections in the supporting floor. Deflection heads may also be required to the underside of roof structures subjected to positive and negative pressures.

To minimise the loss of acoustic performance:

► Refer to C02. S01. P21 – Building acoustics.

For deflection head design:

► Refer to Partitions introduction C04. S01. P116 – construction details 15-22.

## Services

### Penetrations

Penetrations of fire-resistant or sound-insulating constructions for services need careful consideration to ensure that the performance of the element is not downgraded. Consideration also needs to be given to the services themselves so they do not act as the mechanism of fire spread or sound transmission.

► Refer to C02. S01. P41 – Service installations.

### Electrical

The installation of electrical services should be carried out in accordance with BS 7671. The cut-outs in the studs can be used for routing electrical and other small services (Partitions introduction C04. S01. P110 – construction detail 2). Switch boxes and socket outlets can be supported from Gypframe 99 FC 50 Fixing Channel fixed horizontally between studs, or a high performance socket box detail used where higher acoustic performance is required.

Where Gypframe AcouStuds are used, services are routed through 50mm x 28mm 'H' shaped push-outs, at the same centres as shown in Partitions introduction C04. S01. P110 – construction detail 2a for conventional cut-outs. Cables should be protected by conduit, or other suitable precautions taken to prevent abrasion when they pass through the metal frame. Service cut-outs should be aligned to allow easy installation of service. If studs require cutting, cut from the same end of each stud to ensure cut-out alignment.

## Independent support

When designing for the installation of services such as fire dampers and associated ductwork through a GypWall partition, consideration should be given to the size and weight of the damper - this will determine whether it can be supported directly from the partition or needs to be independently supported from the structure.

► Refer to Partitions introduction C04. S01. P121 – construction details 28-31.

### Fixtures

Due to the inherent strength of Rigidur some fixtures can be made directly to the board – please see the **Gyproc Installation Guide** for more information, available to download from gyproc.ie. Heavyweight fixtures (to BS 5234), such as wash basins and wall cupboards, can be fixed using plywood secured with Gypframe Service Support Plates.

▶ Refer to C02. S01. P41 – Service installations.

### Access for maintenance

Gyproc Profilex Access Panels are available to provide access for maintenance. Access panels must be fully compatible with drywall construction and match the fire rating of the partition.

▶ Refer to the Gyproc Technical Department for further information.

### Tiling

Tiles can be applied to the surface of lightweight partition systems.

▶ Refer to C08. S04. P498 – Tiling

### Construction details

For standard GypWall construction details

▶ Refer to Partitions introduction C04. S01. P110 – construction details

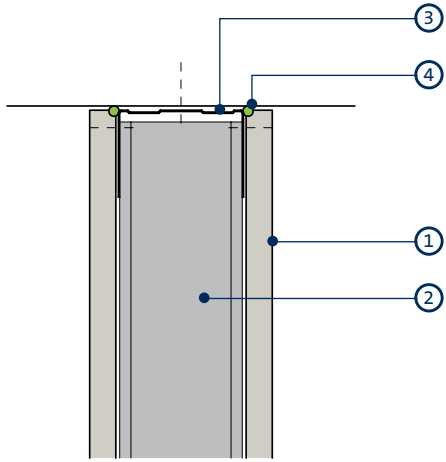


### Handy hint

- The use of insulation within the partition cavity to provide a higher acoustic performance than may initially be required, will help to future proof for subsequent changes of room use
- Cut-outs in the Gypframe Studs can be used to accommodate horizontal service runs. Installers should be made aware of this to avoid vertical misalignment of cut-outs between adjacent studs

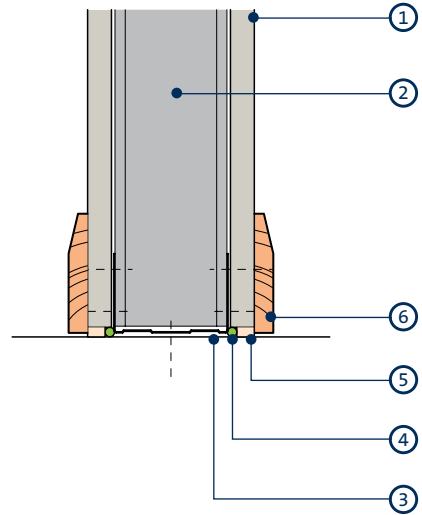
# GypWall EXTREME construction details

1



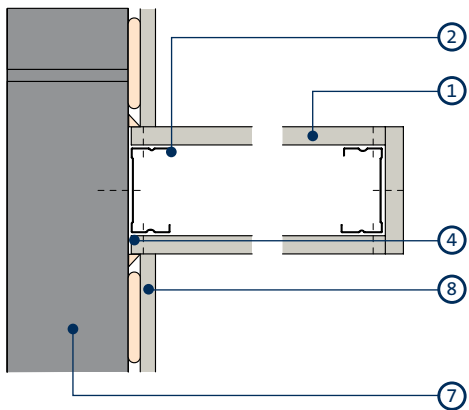
Head

2



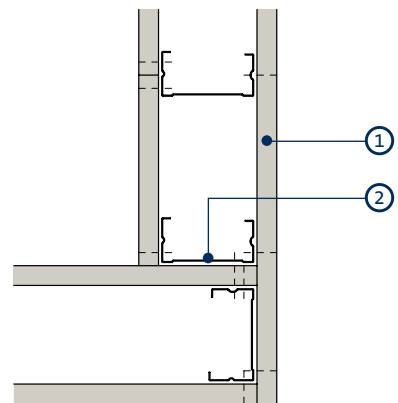
Base

3



Junction with masonry and stop end

4

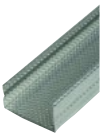


Corner

- 1 Rigidur
- 2 Gypframe 'C' Stud
- 3 Gypframe Deep Flange Floor & Ceiling Channel
- 4 Gyproc Sealant

- 5 Bulk fill with Gyproc jointing materials (where gap exceeds 5mm)
- 6 Skirting
- 7 Internal blockwork
- 8 DriLyner wall lining system

## Gypframe metal components



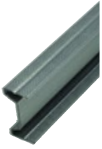
### Gypframe 'C' Studs (70 S 60)

Vertical stud providing acoustic and structural performances designed to receive fixing of board to both sides.



### Gypframe GFS1 Fixing Strap

Used to support horizontal board joints and within deflections heads.



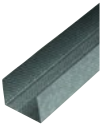
### Gypframe AcouStud (70 AS 50, 146 AS 50)

Vertical stud providing enhanced acoustic and structural performances designed to receive fixing of board to both sides.



### Gypframe GFT1 Fixing T

Used to support horizontal board joints.



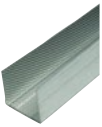
### Gypframe Deep Flange Floor & Ceiling Channels (72 DC 60, 148 DC 60)

Floor and ceiling channels with deep flanges for retaining the Gypframe studs at floor and ceiling junctions for partitions 4200mm to 8000mm high. Also used around openings and in deflection heads (maximum 30mm deflection).



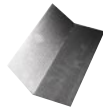
### Gypframe GA5 Internal Fixing Angle

Steel angle providing framing stability and board support.



### Gypframe Extra Deep Flange Floor & Ceiling Channels (72 EDC 80, 148 EDC 80)

Floor and ceiling channels with extra deep flanges for retaining the Gypframe studs at floor and ceiling junctions for partitions over 8000mm high. Also used around openings and in deflection heads (maximum 50mm deflection).



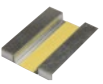
### Gypframe GA6 Splayed Angle

Steel angle providing framing stability and board support.



### Gypframe 99 FC 50 Fixing Channel

A versatile metal fixing channel used to support medium weight fixtures on walls.



### Gypframe Service Support Plate

For installation of 18mm plywood within a partition cavity to support medium to heavyweight fixtures.

## Board products



### Rigidur

Gypsum fibre board with additives for rigidity, durability and mechanical strength.



### Gyproc WallBoard

Standard gypsum plasterboard, used as inner layer.



### Gyproc DuraLine<sup>1</sup>

Gypsum plasterboard with fire resistant additives and a high density core for enhanced sound insulation and impact resistance performance.



### Glasroc F FIRECASE

Non-combustible glass-reinforced gypsum board. Used to form deflection head.



### Gyproc SoundBloc<sup>1</sup>

Gypsum plasterboard with a high density core for enhanced sound insulation performance.



### Gyproc CoreBoard

Gypsum plasterboard with fire and moisture resistant additives. Used to form deflection head.

<sup>1</sup> Also available in a Moisture Resistant (MR) version. MR boards are specified in intermittent wet use areas.

## Fixing products



### Gyproc Drywall Screws

Corrosion resistant self-tapping steel screws for fixing board-to-timber and board-to-metal framing less than 0.8mm thick.



### Rigidur Screws

Corrosion resistant self-tapping steel screws designed for fixing Rigidur board to framing. (Gypframe 'C' Studs and Gypframe AcouStuds less than 0.8mm thick).



### Gyproc Collated Drywall Screws

Corrosion resistant self-tapping steel screws for fixing board-to-timber and board-to-metal framing less than 0.8mm thick.



### Gyproc Jack-Point Screws

Corrosion resistant self-tapping steel screws for fixing board to metal framing 0.8mm thick and greater ('I' stud 0.6mm thick and greater).



### Gyproc Wafer Head Drywall Screws

Corrosion resistant self-tapping steel screws for fixing metal to metal framing less than 0.8mm thick ('I' studs less than 0.6mm thick).



### Gyproc Wafer Head Jack-Point Screws

Corrosion resistant self-tapping steel screws for fixing metal to metal framing 0.8mm thick ('I' studs 0.6mm thick and greater).

## Plasterboard accessories



### Gyproc Jointing Material

Jointing compounds, ready mixes and adhesives for reinforcement and finishing of board joints.



### Gyproc Corner Tape

A paper tape bonded to two corrosion resistant steel strips.



### Gyproc Control Joint

To accommodate structural movement of up to 7mm.



### Gyproc Paper Joint Tape

A paper tape designed for reinforcement of flat joints or internal angles.



### Gyproc FireStrip

A soft extruded linear intumescent gap sealer to maintain fire resistance located directly to the underside of the soffit when forming a deflection head.



### Gyproc Drywall Primer

Used to prepare for painting. Tub contents 10 litre.



### Gyproc Sealant

Used to seal air paths for optimum sound insulation.

### Finishing products



#### Gyproc Skimcoat

To provide a plaster skim finish on most common backgrounds including undercoat plasters and plasterboard. Can provide enhanced acoustic performance.



#### Gyproc Carlite Finish

To provide a plaster skim finish on most common backgrounds including undercoat plasters and plasterboard. Can provide enhanced acoustic performance.



#### Gyproc Carlite Ultra Finish

Offers all the benefits of Gyproc Skimcoat and Gyproc Carlite Finish with a reduced set time of 90 - 120 mins, making it ideal for smaller jobs!



#### Gyproc Magnetic Plaster

To provide a plaster skim finish that provides an attraction to magnets used to finish a wide range of backgrounds, including undercoat plasters and plasterboard.



#### Plaster accessories

Designed for reinforcement and finishing of board joints before plaster skimming.

### Insulation products



#### Isover Acoustic Roll

Glass mineral wool for enhanced acoustic and thermal performance.



#### Isover ULTIMATE™ Piano Plus

Glass mineral wool for enhanced acoustic and fire performance.

# GypWall EXTREME installation overview

This is intended to be a basic description of how the system is built.



Gypframe Deep Flange or Extra Deep Flange Floor & Ceiling Channels are suitably fixed to the floor and soffit.



Gypframe Studs are suitably fixed to abutments.



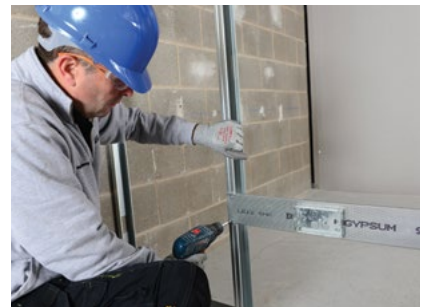
The perimeter of the partition is then sealed on both sides with Cyproc Sealant.



Gypframe studs are then friction fitted into the Gypframe Deep Flange Floor & Ceiling Channels at required centres.



Door openings are constructed to the Heavy and Severe Duty detail.



M&E services can be located within the partition cavity.



Isover acoustic insulation can also be added to the partition cavity for increased acoustic performance.



Gyproc DuraLine, Gyproc SoundBloc or Gyproc WallBoard plasterboards may be installed as an inner layer with Gyproc Drywall Screws.



Rigidur boards are then fixed as the outer layer to all Gypframe framing members with Rigidur Screws.



## Additional information

For full installation details, refer to the **Gyproc Installation Guide**, available to download from [gyproc.ie](http://gyproc.ie)



# GypWall QUIET SF

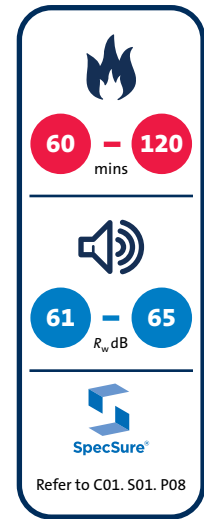
Single frame acoustic separating wall system



## GypWall QUIET SF

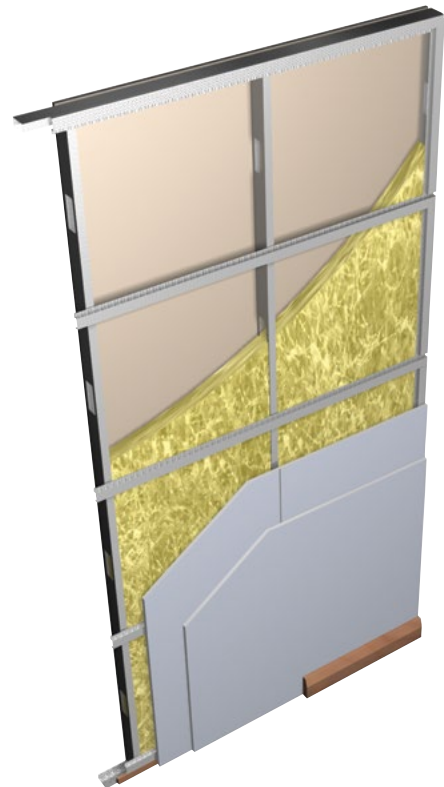
GypWall QUIET SF is a non-loadbearing partition, which provides high levels of sound insulation up to and exceeding regulatory requirements for separating walls.

GypWall QUIET SF offers high levels of acoustic performance within a narrow footprint. This makes it the ideal solution for a wide range of buildings where it is important to provide occupants with a comfortable acoustic environment, whilst at the same time maximising available floor area, for example, schools and hospitals.



### Key benefits

- Very efficient use of floor space due to a high level of acoustic performance being achieved with a minimal partition width
- Reduced sound transmission is achieved through the use of Gypframe RB1 Resilient Bar to provide a high degree of isolation between the Gypframe 'C' Studs and the high performance Gyproc plasterboard lining
- Additional acoustic performance can be achieved with the application of Gyproc Finish Plasters on selected specifications



### You may also be interested in...

Looking for an increase in acoustic performance? For example, if designing for a prestigious development or to achieve credits towards a BREEAM framework.

#### GypWall QUIET IWL

Provides greater levels of acoustic insulation, through the use of totally isolated twin stud frameworks.

► Refer to C04, S08, P231 – GypWall QUIET IWL.

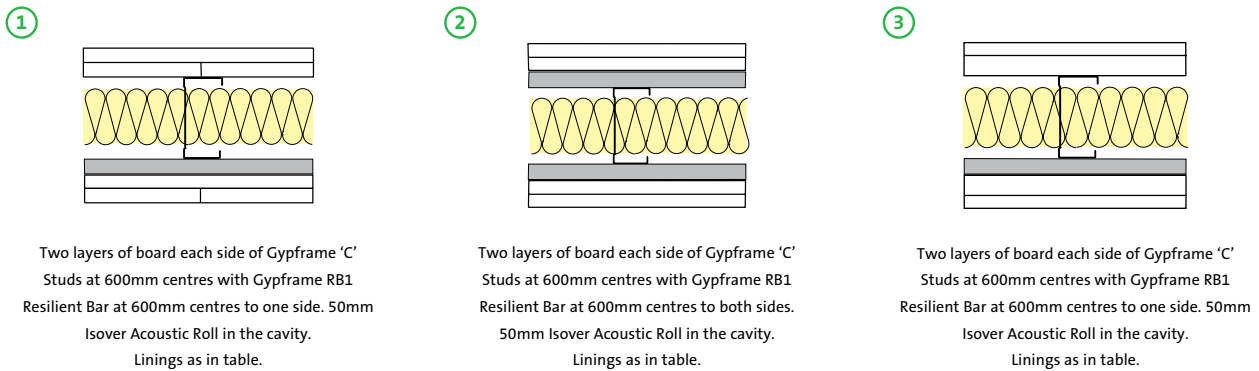
# GypWall QUIET SF performance

## 70mm, 92mm and 146mm Gypframe 'C' Stud

For details of when to specify fire resistance using EN  
 ► Refer to C02. S01. P18



Table 1a — Solutions to satisfy the requirements of BS EN 1364-1: 1999



Detail	Partition thickness mm	Board type	Lining thickness mm	Stud size mm	Max. partition height <sup>1</sup> mm	Sound insulation $R_w (R_w + C_{tr})$ dB <sup>2</sup>		Duty rating	Approx. weight kg/m <sup>2</sup>	System reference	
						Any <sup>2</sup> finish	Skim <sup>3</sup> only			Any <sup>2</sup> finish	Skim <sup>3</sup> only
<b>60 minutes fire resistance</b> (EN)											
①	137	Gyproc SoundBloc	2 x 12.5	70	4000	61 (53)	-	Severe	43	A316008	-
②	152	Gyproc SoundBloc	2 x 12.5	70	3200	62 (55)	-	Severe	43	A316012	-
①	159	Gyproc SoundBloc	2 x 12.5	92	5000	61 (53)	-	Severe	43	A316014	-
②	174	Gyproc SoundBloc	2 x 12.5	92	4000	63 (55)	-	Severe	43	A316015	-
①	213	Gyproc SoundBloc	2 x 12.5	146	6800	62 (56)	-	Severe	43	A316016	-
②	228	Gyproc SoundBloc	2 x 12.5	146	5700	64 (58)	-	Severe	43	A316018	-
<b>90 minutes fire resistance</b> (EN)											
①	147	Gyproc SoundBloc	2 x 15	70	4200	62 (54)	-	Severe	51	A316009	-
③	150	Gyproc Plank + Gyproc SoundBloc	1 x 19 + 1 x 12.5	70	3800	63 (54)	-	Severe	54	A316011	-
②	162	Gyproc SoundBloc	2 x 15	70	3200	65 (57)	-	Severe	51	A316013	-
①	223	Gyproc SoundBloc	2 x 15	146	5000	62 (57)	63 (57)	Severe	51	A316017	A316017S
②	238	Gyproc SoundBloc	2 x 15	146	5000	65 (59)	-	Severe	51	A316019	-
<b>120 minutes fire resistance</b> (EN)											
①	147	Gyproc FireLine + Gyproc DuraLine	1 x 15 + 1 x 15	70	4000	61 (53)	62 (53)	Severe	53	Q606040	Q606040S

► For further assistance in choosing the right solution for your project, try our System Selector; an online tool that enables quick and easy filtering by performance criteria. It provides system specific information downloads including BIM (Revit) objects. Go to [gyproc.ie](http://gyproc.ie)

<sup>1</sup>The maximum heights quoted are limited by the fire state field of application or by limiting deflection of L/240 at 200 Pa, whichever is the more onerous.

<sup>2</sup>Sound insulation performance for partitions finished using jointing or plaster skim.

<sup>3</sup>Sound insulation performance for partitions finished with a 2mm skim finish of Gyproc Finish Plasters.

<sup>4</sup>These Gyproc Approved Systems are designed to achieve minimum  $D_{n,TW} + C_{tr}$  45dB, subject to Pre-Completion Testing (Refer to Partitions introduction C04. S01. P109 – table 1)

**(NB)** For heights above 4200mm Gypframe Deep Flange Floor & Ceiling Channel should be used at base and at head (subject to deflection criteria).

**(NB)** The fire resistance and sound insulation performances are for imperforate partitions, walls and ceilings incorporating boards with all joints taped and filled, or skimmed according to Gyproc's recommendations. The quoted performances are achieved only if Gyproc and Isover components are used throughout, and the Company's fixing recommendations are strictly observed. Any variation in the specifications should be checked with Gyproc.

## GypWall QUIET SF performance (continued)

### 70mm, 92mm and 146mm Gypframe 'C' Stud

For details of when to specify fire resistance using BS  
 ▶ Refer to C02. S01. P18



Table 1b — Solutions to satisfy requirements of BS 476: Part 22: 1987

①	②	③
Two layers of board each side of Gypframe 'C' Studs at 600mm centres with Gypframe RB1 Resilient Bar at 600mm centres to one side. 50mm Isover Acoustic Roll in the cavity. Linings as in table.	Two layers of board each side of Gypframe 'C' Studs at 600mm centres with Gypframe RB1 Resilient Bar at 600mm centres to both sides. 50mm Isover Acoustic Roll in the cavity. Linings as in table.	Two layers of board each side of Gypframe 'C' Studs at 600mm centres with Gypframe RB1 Resilient Bar at 600mm centres to one side. 50mm Isover Acoustic Roll in the cavity. Linings as in table.

Detail	Partition thickness mm	Board type	Lining thickness mm	Stud size mm	Max. partition height <sup>1</sup> mm	Sound insulation $R_w (R_w + C_{tr})$ dB <sup>4</sup>		Duty rating	Approx. weight kg/m <sup>2</sup>	System reference	
						Any <sup>2</sup> finish	Skim <sup>3</sup> only			Any <sup>2</sup> finish	Skim <sup>3</sup> only
<b>60 minutes fire resistance (BS)</b>											
①	137	Gyproc SoundBloc	2 x 12.5	70	4000	61 (53)	-	Severe	43	A316008	-
②	152	Gyproc SoundBloc	2 x 12.5	70	3200	62 (55)	-	Severe	43	A316012	-
①	159	Gyproc SoundBloc	2 x 12.5	92	5000	61 (53)	-	Severe	43	A316014	-
②	174	Gyproc SoundBloc	2 x 12.5	92	4000	63 (55)	-	Severe	43	A316015	-
①	213	Gyproc SoundBloc	2 x 12.5	146	6800	62 (56)	-	Severe	43	A316016	-
②	228	Gyproc SoundBloc	2 x 12.5	146	5700	64 (58)	-	Severe	43	A316018	-
<b>90 minutes fire resistance (BS)</b>											
①	147	Gyproc SoundBloc	2 x 15	70	4200	62 (54)	-	Severe	51	A316009	-
③	150	Gyproc Plank + Gyproc WallBoard	1 x 19 + 1 x 12.5	70	3800	61 (53)	-	Severe	49	A316010	-
③	150	Gyproc Plank + Gyproc SoundBloc	1 x 19 + 1 x 12.5	70	3800	63 (54)	-	Severe	54	A316011	-
②	162	Gyproc SoundBloc	2 x 15	70	3200	65 (57)	-	Severe	51	A316013	-
①	223	Gyproc SoundBloc	2 x 15	146	6900	62 (57)	63 (57)	Severe	51	A316017	A316017S
②	238	Gyproc SoundBloc	2 x 15	146	5700	65 (59)	-	Severe	51	A316019	-
<b>120 minutes fire resistance (BS)</b>											
①	147	Gyproc FireLine + Gyproc DuraLine	1 x 15 + 1 x 15	70	4000	61 (53)	62 (53)	Severe	53	Q606040	Q606040S

▶ For further assistance in choosing the right solution for your project, try our System Selector; an online tool that enables quick and easy filtering by performance criteria. It provides system specific information downloads including BIM (Revit) objects. Go to [gyproc.ie](https://www.gyproc.ie)

<sup>1</sup> Based on a limiting deflection of L/240 at 200 Pa. For increased heights Gypframe 'I' Studs could be used (Refer to table 2 within this section)

<sup>2</sup> Sound insulation performance for partitions finished using jointing or plaster skim.

<sup>3</sup> Sound insulation performance for partitions finished with a 2mm skim finish of Gyproc Finish Plasters.

<sup>4</sup> These Gyproc Approved Systems are designed to achieve minimum  $D_{nT,w} + C_{tr}$  45dB, subject to Pre-Completion Testing (Refer to Partitions introduction C04. S01. P109 – table 1)

**(NB)** For heights above 4200mm Gypframe Deep Flange Floor & Ceiling Channel should be used at base and at head (subject to deflection criteria).

**(NB)** The fire resistance and sound insulation performances are for imperforate partitions, walls and ceilings incorporating boards with all joints taped and filled, or skimmed according to Gyproc's recommendations. The quoted performances are achieved only if Gyproc and Isover components are used throughout, and the Company's fixing recommendations are strictly observed. Any variation in the specifications should be checked with Gyproc.

## GypWall QUIET SF performance (continued)

### 70mm and 92mm Gypframe 'I' Stud

Table 2 – Increased heights using Gypframe 'I' Studs (mm)<sup>1</sup>

Studs at 600mm centres	2 x 12.5mm board, Gypframe RB1 Resilient Bar to one side	2 x 15mm board, Gypframe RB1 Resilient Bar to one side	19mm + 12.5mm board, Gypframe RB1 Resilient Bar to one side	Gypframe RB1 Resilient Bar both sides
70 'I' 50	4400	4600	4200	3700
70 'I' 70	4800	5000	4700	4300
92 'I' 90	6300	6400	6100	5800

<sup>1</sup> The above have not been subjected to acoustic tests and therefore any sound insulation performances are opinion only.

**NB** For heights between 4200mm and 8000mm Gypframe Deep Flange Floor & Ceiling Channel should be used.

## Building design

GypWall QUIET SF comprises Gyprframe 'C' Studs installed at 600mm centres within Gyprframe Floor & Ceiling Channels and Gyprframe RB1 Resilient Bars horizontally fixed to one or both sides.

## Planning – key factors

The position of services and heavy fixtures should be pre-determined and their installation planned into the frame erection stage. Timber sole plates should be considered where the floor is uneven. All penetrations will need to be adequately fire-stopped.



### Handy hint

Be aware that if working to centre lines on a plan, GypWall QUIET SF systems incorporating Gyprframe RB1 Resilient Bar to one side only are not symmetrical.

## Fixing floor and ceiling channels

Gyprframe Floor & Ceiling Channels must be securely fixed with a row of fixings at 600mm maximum centres. For 94mm channels and above, two rows of staggered fixings are required, each row at 600mm centres and each fixing 25mm in from the flange. If the floor is uneven, a 38mm thick timber sole plate equal to the width of the channel should be used.

If the concrete or screeded floor is new, consideration should be given to the installation of a damp-proof membrane between the floor surface and the channel or sole plate.



### Important information

For partition heights above 4200mm, Gyprframe Deep Flange Floor & Ceiling Channels should be used.

## Splicing

To extend studs, overlap by 600mm (minimum). Fix together using Gyproc Wafer Head Drywall Screws or steel pop rivets (two to each flange).

- ▶ Refer to Partitions introduction C04. S01. P110 – construction detail 1

## Partition to structural steelwork junctions

When designing the layout of rooms requiring separation by sound insulating walls abutting structural steelwork, consideration should be given to the potential loss of sound insulation performance through the steelwork.

If you require a wider partition to fully encompass structural steel, refer to GypWall QUIET or GypWall QUIET IWL.

- ▶ Refer to C02. S01. P21 – Building acoustics.

## Door openings

Any openings will require very careful detailing to minimise the loss of acoustic performance of the partition. Consult with an Acoustic Consultant. Specialist heavy acoustic doorsets may require additional support.

- ▶ Refer to construction detail 8 within this section.

## Framing surround for openings

Where services such as horizontal ducts, fire dampers and access panels are required to penetrate the wall, their position should be pre-determined in order that a framed opening can be provided. The openings should be constructed using established metal stud procedures.

- ▶ Refer to Partitions introduction C04. S01. P121 – construction details 28-31.

## Cavity barriers

Where required to maintain fire performance, suitable fire stopping (by others) should be installed full filled within the partition cavity to form a suitable closure.

## Acoustic performance

The partition achieves high levels of sound insulation by virtue of the separation between the board and the stud framing afforded by the Gyprframe RB1 Resilient Bars. It is important that, when screw-fixing boards, the screws do not contact the stud framing and also that services, fixtures, etc, do not form a bridge between the lining boards on each side of the partition.

For optimum performance all air paths should be sealed. Gyproc Sealant should be applied to the perimeter of the inner layer immediately prior to fitting the face layer board on the side(s) of the partition where resilient bars are located.

## Deflection heads

Partition head deflection designs may be necessary to accommodate deflections in the supporting floor. Deflection heads may also be required to the underside of roof structures subjected to positive and negative pressures.

The partitions can incorporate head deflection designs with only a slight reduction in sound insulation performance. Refer to construction detail 3 within this section.

To minimise the loss of acoustic performance:

- ▶ Refer to C02. S01. P21 – Building acoustics.

## Services

### Penetrations

Penetrations of fire-resistant or sound-insulating constructions for services need careful consideration to ensure that the performance of the element is not downgraded. Consideration also needs to be given to the services themselves so they do not act as the mechanism of fire spread or sound transmission.

- ▶ Refer to C02. S01. P41 – Service installations.

### Electrical

The installation of electrical services should be carried out in accordance with *BS 7671*. The cut-outs in the studs can be used for routing electrical and other small services (refer to Partitions introduction C04. S01. P110 – construction detail 2). Switch boxes and socket outlets can be supported from Gypframe 99 FC 50 Fixing Channel fixed horizontally between studs, or a high performance socket box detail used where higher acoustic performance is required.

Where Gypframe AcouStuds are used, services are routed through 50mm x 28mm 'H' shaped push-outs, at the same centres as shown in Partitions introduction C04. S01. P110 – construction detail 2a for conventional cut-outs. Cables should be protected by conduit, or other suitable precautions taken to prevent abrasion when they pass through the metal frame. Service cut-outs should be aligned to allow easy installation of service. If studs require cutting, cut from the same end of each stud to ensure cut-out alignment.

### Independent support

When designing for the installation of services such as fire dampers and associated ductwork through a GypWall partition, consideration should be given to the size and weight of the damper - this will determine whether it can be supported directly from the partition or needs to be independently supported from the structure.

- ▶ Refer to Partitions introduction C04. S01. P122 – construction details 29-31.

### Fixtures

Lightweight fixtures can be made directly to the partitions. Medium weight fixtures can be made to Gypframe 99 FC 50 Fixing Channel. Heavyweight fixtures (to *BS 5234*), such as wash basins and wall cupboards, can be fixed using plywood secured with a Gypframe Service Support Plates. In all instances the Gypframe Service Support Plates are fixed to the side without a Gypframe RB1 Resilient Bar.

Medium and heavy weight fixtures can only be made when the lining boards are fixed directly to the stud framing. The installation of fixings may downgrade the acoustic performance of the wall, refer to C04. S05. P197 – Acoustic performance.

- ▶ Refer to C02. S01. P41 – Service installations.

For alternative solutions, where fixtures are required to both sides of a partition, consider using GypWall QUIET or GypWall QUIET IWL.

### Board finishing

- ▶ Refer to C08. S01. P483 – Finishes.

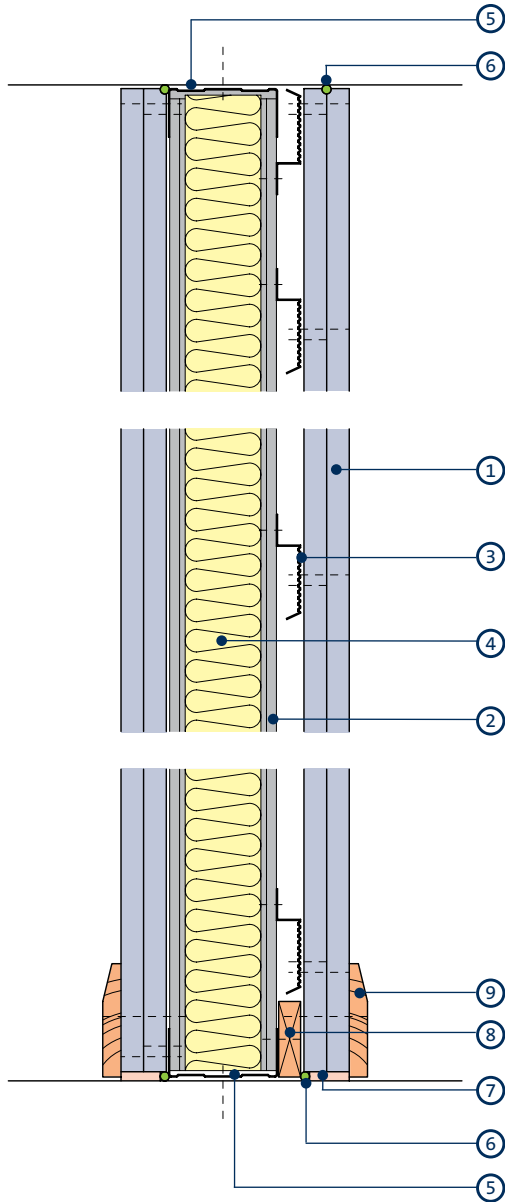
### Tiling

Tiles can be applied to the surface of lightweight partition systems.

- ▶ Refer to C08. S04. P498 – Tiling.

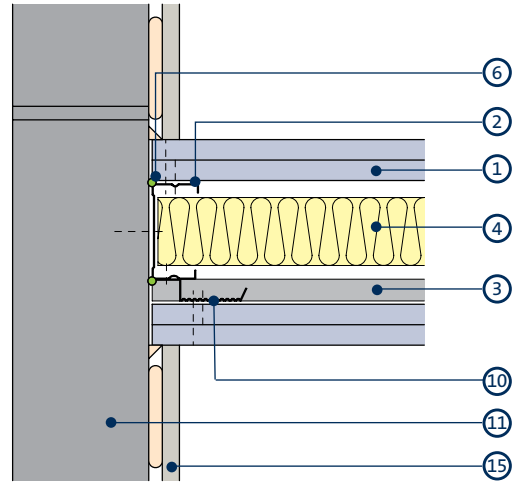
# GypWall QUIET SF construction details

1



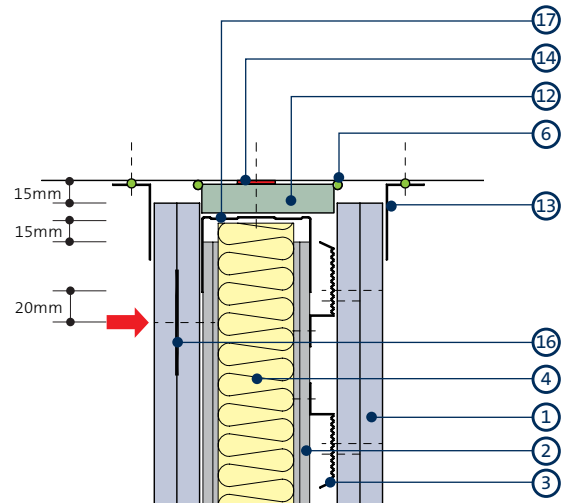
Head and base

2



Junction with masonry

3



Deflection head for 15mm downward movement and 60 minutes fire resistance - BS 476 Part 22: 1987

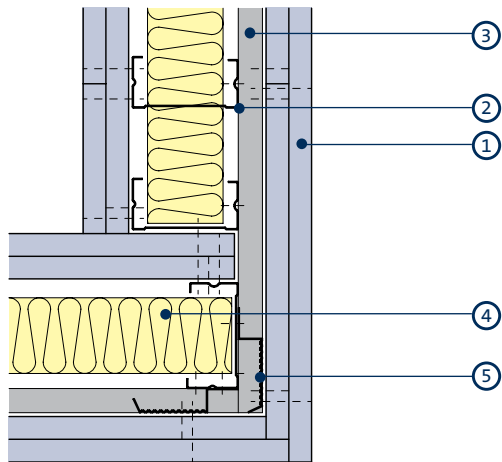
- 1 Gyproc plasterboard
- 2 Gypframe 'C' Stud
- 3 Gypframe RB1 Resilient Bar
- 4 50mm Isover Acoustic Roll
- 5 Gypframe Floor & Ceiling Channel
- 6 Gyproc Sealant
- 7 Bulk fill with Gyproc jointing materials (where gap exceeds 5mm)
- 8 Timber packer (16 x 50mm)
- 9 Skirting
- 10 Vertical Gypframe RB1 Resilient Bar noggings

- 11 Blockwork
- 12 Gyproc CoreBoard or Glasroc F FIRECASE (width of Gypframe stud and Gypframe RB1 Resilient Bar)
- 13 Gypframe Steel Angle
- 14 Gyproc FireStrip
- 15 **Drilyner** wall lining system
- 16 Gypframe GFS1 Fixing Strap
- 17 Gypframe Deep Flange Floor & Ceiling Channel suitable fixed through fire-stop to structure

**NB** No fixings should be made through the boards into the flanges of the head channel. The arrow (➡) denotes the position of the uppermost board fixing, which should be made into Gypframe GFS1 Fixing Strap. Continuous Gyproc FireStrip must be installed as shown to maintain fire performance.

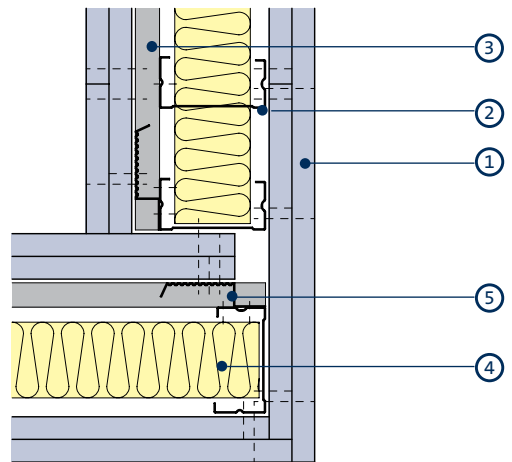
## GypWall QUIET SF construction details (continued)

4



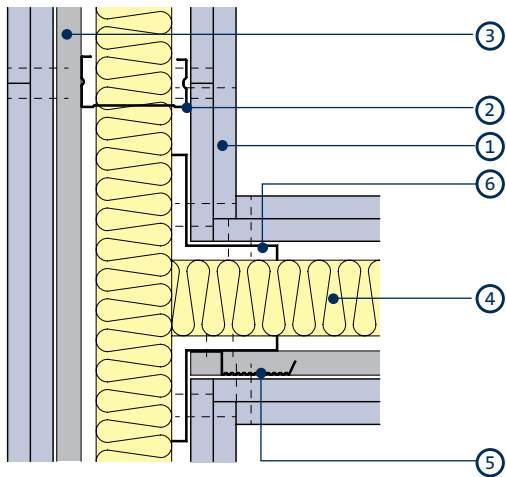
Corner - resilient bar to external corner

5



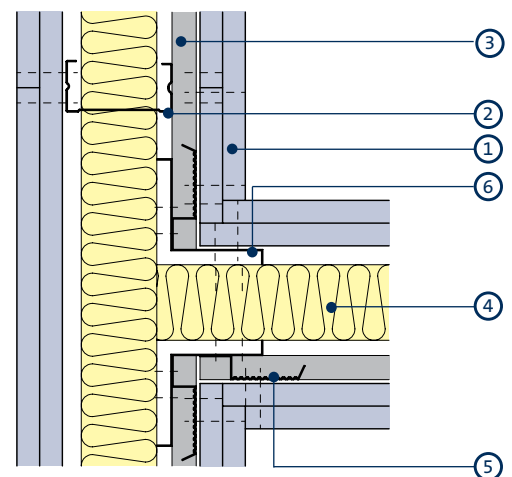
Corner - resilient bar to internal corner

6



'T' junction (resilient bar on opposite side)

7

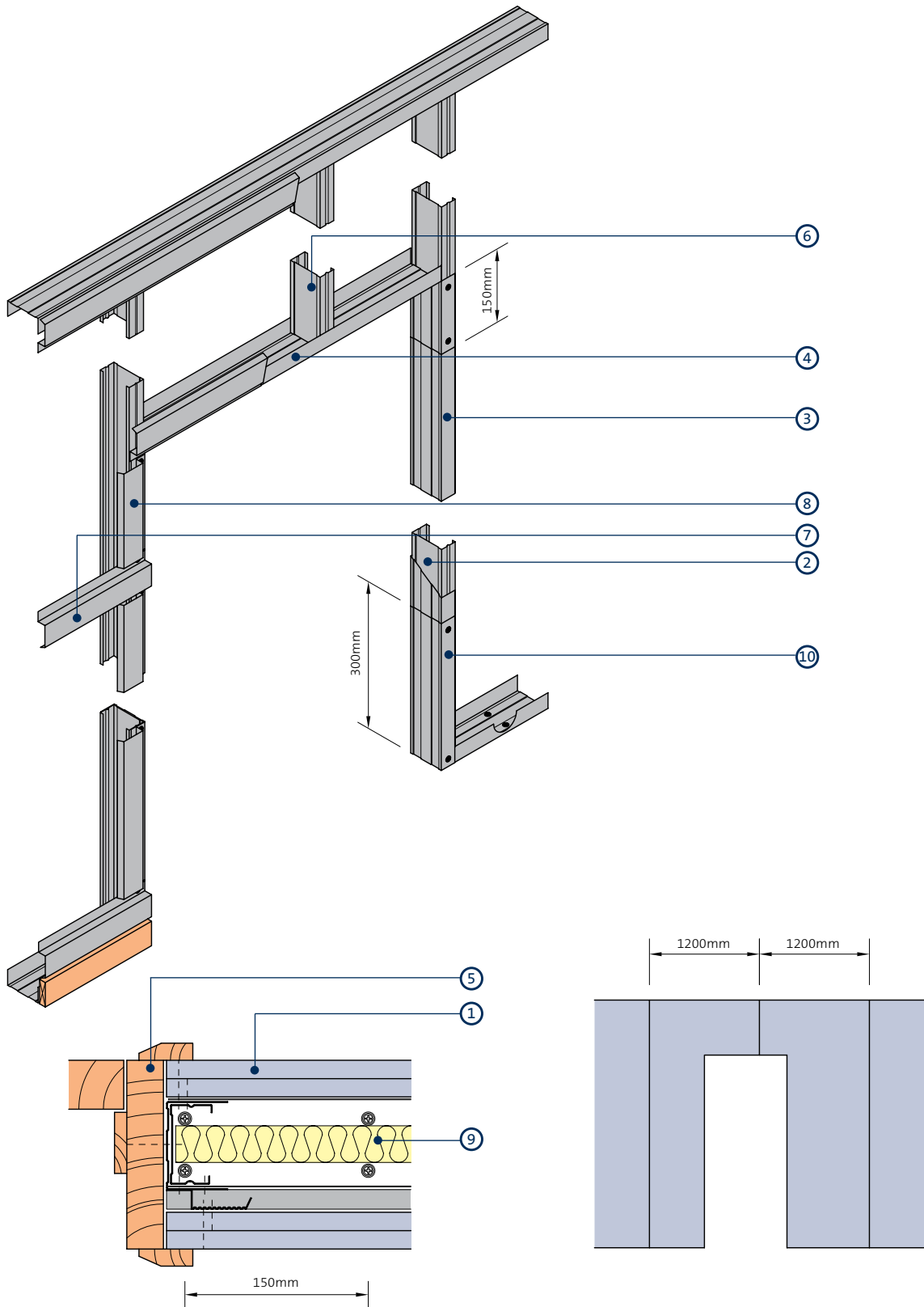


'T' junction (resilient bar on abutment side)

- 1 Gyproc plasterboard
- 2 Gypframe 'C' Stud
- 3 Gypframe RB1 Resilient Bar

- 4 50mm Isover Acoustic Roll
- 5 Vertical Gypframe RB1 Resilient Bar nogging
- 6 Gypframe GA5 Internal Fixing Angle

8



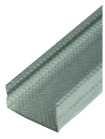
Door frame to satisfy BS 5234: Parts 1 and 2: 1992 - Heavy and Severe Duty (up to 60kg door)

- |  |  |
|--|--|
| 1 Gyproc plasterboard  | 6 Gypframe 'C' Stud to maintain stud module                                      |
| 2 Gypframe 'C' Stud  | 7 Gypframe RB1 Resilient Bar   |
| 3 Gypframe Folded Edge Standard Floor & Ceiling Channel                                | 8 Gypframe RB1 Resilient Bar vertical nogging                                    |
| 4 Gypframe Folded Edge Standard Floor & Ceiling Channel cut and bent to form door head | 9 50mm Isover Acoustic Roll  |
| 5 Timber door frame and architrave   | 10 Gypframe Folded Edge Standard Floor & Ceiling Channel cut and extend up studs |

**NB** Advice should be sought from the door manufacturer prior to the construction of these details.

# GypWall QUIET SF system components

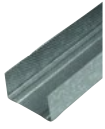
## Gypframe metal components



**Gypframe 'C' Studs (70 S 50, 92 S 50, 146 S 50)**  
Vertical stud providing acoustic and structural performances designed to receive fixing of board after installation of Gypframe RB1 Resilient Bars.



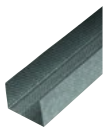
**Gypframe 99 FC 50 Fixing Channel**  
A versatile metal fixing channel used to support medium weight fixtures on walls.



**Gypframe Folded Edge Standard Floor & Ceiling Channels (72 FEC 50, 94 FEC 50, 148 FEC 50)**  
Standard floor and ceiling channels for retaining the Gypframe studs at floor and ceiling junctions and around openings to heights not exceeding 4200mm.



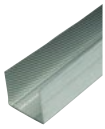
**Gypframe GFS1 Fixing Strap**  
Used to support horizontal board joints and within deflection head.



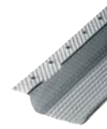
**Gypframe Deep Flange Floor & Ceiling Channels (72 DC 60, 94 DC 60, 148 DC 60)**  
Floor and ceiling channels with deep flanges for retaining the Gypframe studs at floor and ceiling junctions for partitions 4200mm to 8000mm high. Also used around openings and in deflection heads (maximum 30mm deflection).



**Gypframe GFT1 Fixing T**  
Used to support horizontal board joints.



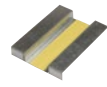
**Gypframe Extra Deep Flange Floor & Ceiling Channels (72 EDC 80, 94 EDC 70, 148 EDC 80)**  
Floor and ceiling channels with extra deep flanges for retaining the Gypframe studs at floor and ceiling junctions for partitions over 8000mm high. Also used around openings and in deflection heads (maximum 50mm deflection).



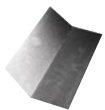
**Gypframe RB1 Resilient Bar**  
Acoustically engineered channel to separate board fixing from the primary frame. Fixed horizontally to face of studs.



**Gypframe GA5 Internal Fixing Angle**  
Steel angle providing framing stability and board support.



**Gypframe Service Support Plate**  
For installation of 18mm plywood within a partition cavity to support medium to heavyweight fixtures.



**Gypframe GA6 Splayed Angle**  
Steel angle providing framing stability and board support.

## Board products



**Gyproc SoundBloc<sup>1</sup>**  
Gypsum plasterboard with a high density core for enhanced sound insulation performance.



**Gyproc WallBoard**  
Standard gypsum plasterboard.



**Gyproc Plank**  
Standard gypsum plasterboard located as an inner layer.



**Gyproc Duraline<sup>1</sup>**  
Gypsum plasterboard with fire resistant additives and a high density core for enhanced sound insulation and impact resistance performance.

<sup>1</sup> Also available in a Moisture Resistant (MR) version. MR boards are specified in intermittent wet use areas.

## GypWall QUIET SF system components (continued)

### Board products



#### Gyproc FireLine<sup>1</sup>

Gypsum plasterboard with fire resistant additives.



#### Gyproc CoreBoard

Gypsum plasterboard with fire and moisture resistant additives. Used to form deflection head.



#### Glasroc F FIRECASE

Non-combustible glass-reinforced gypsum board. Used to form deflection head.

<sup>1</sup> Also available in a Moisture Resistant (MR) version. MR boards are specified in intermittent wet use areas.

### Fixing products



#### Gyproc Drywall Screws

Corrosion resistant self-tapping steel screws for fixing board-to-timber and board-to-metal framing less than 0.8mm thick. (I' studs less than 0.6mm thick).



#### Gyproc Jack-Point Screws

Corrosion resistant self-tapping steel screws for fixing board to metal framing 0.8mm thick and greater (I' studs 0.6mm thick and greater).



#### Gyproc Collated Drywall Screws

Corrosion resistant self-tapping steel screws for fixing board-to-timber and board-to-metal framing less than 0.8mm thick (I' studs less than 0.6mm thick).



#### Gyproc Wafer Head Jack-Point Screws

Corrosion resistant self-tapping steel screws for fixing metal to metal framing 0.8mm thick and greater (I' studs 0.6mm thick and greater).



#### Gyproc Wafer Head Drywall Screws

Corrosion resistant self-tapping steel screws for fixing metal to metal framing less than 0.8mm thick (I' studs less than 0.6mm thick).

### Plasterboard accessories



#### Gyproc Jointing Material

Jointing compounds, ready mixes and adhesives for reinforcement and finishing of board joints.



#### Gyproc FireStrip

A soft extruded linear intumescent gap sealer to maintain fire resistance located directly to the underside of the soffit when forming a deflection head.



#### Gyproc Sealant

Used to seal air paths for optimum sound insulation.



#### Gyproc Drywall Primer

Used to prepare for painting. Tub contents 10 litre.

## GypWall QUIET SF system components (continued)

### Finishing products



#### Gyproc Skimcoat

To provide a plaster skim finish on most common backgrounds including undercoat plasters and plasterboard. Can provide enhanced acoustic performance.



#### Gyproc Carlite Finish

To provide a plaster skim finish on most common backgrounds including undercoat plasters and plasterboard. Can provide enhanced acoustic performance.



#### Gyproc Carlite Ultra Finish

Offers all the benefits of Gyproc Skimcoat and Gyproc Carlite Finish with a reduced set time of 90 - 120 mins, making it ideal for smaller jobs.



#### Gyproc Magnetic Plaster

To provide a plaster skim finish that provides an attraction to magnets used to finish a wide range of backgrounds, including undercoat plasters and plasterboard.



#### Plaster accessories

Designed for the reinforcement and finishing of board joints before plaster skimming.

### Insulation products



#### Isover Acoustic Roll

Glass mineral wool for enhanced acoustic and thermal performance.

# GypWall QUIET SF installation overview

This is intended to be a basic description of how the system is built.



Gypframe Floor & Ceiling channels are suitably fixed to the floor and soffit.

**NB** If you are using Gypframe RB1 Resilient Bars on one side of the partition only, the dimensions will be offset by 16mm. This needs to be considered when detailing to show locations of partition layouts.



Gypframe 'C' Studs are suitably fixed to abutments and door openings.

**NB** Ensure Gyproc CoreBoard to the deflection head takes into account the width of the Gypframe RB1 Resilient Bars.



The perimeter of the partition is then sealed with Gyproc Sealant except where Gypframe RB1 Resilient Bars are to be installed on that side. Where Gypframe RB1 Resilient Bars are to be installed, the Gyproc Sealant is applied to the perimeter of the first layer of board.



Gypframe 'C' Studs are fitted vertically to a friction-fit within the channel sections, to form the framework. Studs are fitted to all face the same way.



Gypframe RB1 Resilient Bars are fixed transverse to the stud framing. Gypframe RB1 Resilient Bars are joined by nesting them together over a Gypframe 'C' Stud using Gyproc Wafer Head Drywall Screws. Gypframe RB1 Resilient Bars are normally fixed with the base flange on the top side, with the exception of the uppermost bar, which is fixed base flange down to provide board fixing at the head.



Gypframe RB1 Resilient Bars are installed vertically to abutment and door studs to accept perimeter fixings for the Gyproc plasterboard linings.



Isover Acoustic Roll insulation is added to the partition cavity for optimal acoustic performance.



Gyproc plasterboards are fixed with Gyproc Drywall Screws to the Gypframe RB1 Resilient Bars with all joints staggered. Where Gyproc Plank is required as an inner layer, it is fixed horizontally to the Gypframe RB1 Resilient Bars at each bar position.

**NB** To maintain acoustic performance care must be taken to select the correct length screws to avoid them contacting or penetrating the Gypframe 'C' Studs when fixing Gyproc plasterboards to Gypframe RB1 Resilient Bar.

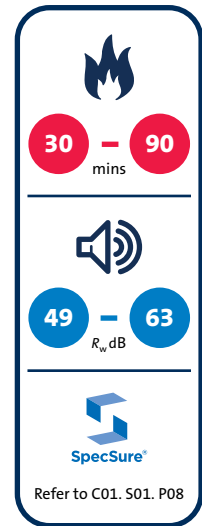
# GypWall STAGGERED

Staggered stud acoustic partition system



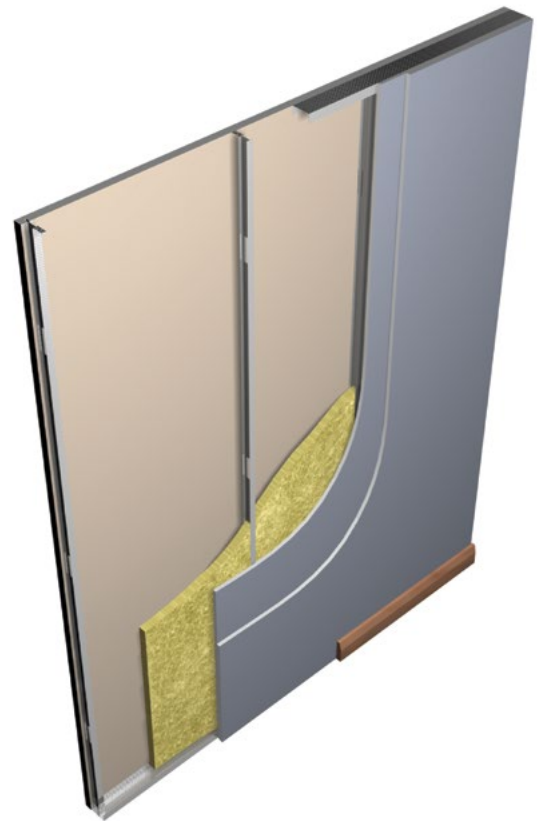
# GypWall STAGGERED

**GypWall STAGGERED** is a non-loadbearing stud partition incorporating a single framework with staggered studs. This provides very high levels of sound insulation with minimal footprint. It is suitable for a wide range of applications, including student accommodation, hotels and offices, where the optimal balance of acoustic performance and partition width are required.



## Key benefits

- Reduced sound transmission is achieved by staggering alternate studs within a single framework, which partially decouples the plasterboard linings on each side of the partition
- Acoustic performance, comparable to a twin frame partition system, is achievable when using the 92 / 148 combination, with the footprint of a single frame solution
- Capable of meeting regulatory acoustic requirements for separating walls in residential conversion projects where space is at a premium
- Allows the inclusion of pattresses to each side of the system without compromising acoustic performance when using 92 / 148 combination



## You may also be interested in...

Looking for an increase in acoustic performance? **GypWall QUIET** and **GypWall QUIET IWL** provide greater levels of acoustic insulation through the use of twin stud frameworks. They can also be used to accommodate structural steel columns.

- ▶ Refer to C04, S07, P219 – **GypWall QUIET** and C04, S08, P231 – **GypWall QUIET IWL**

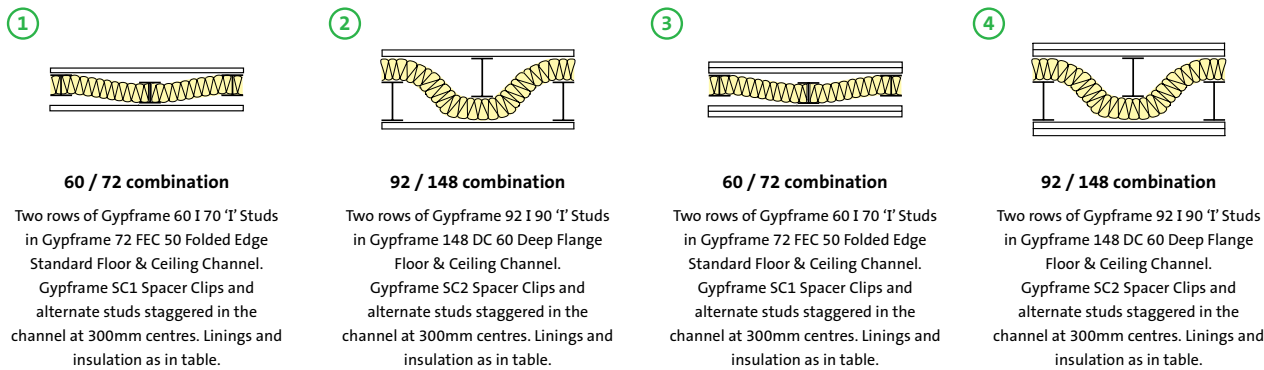
# GypWall STAGGERED performance

60 / 72 and 92 / 148 combinations

For details of when to specify fire resistance using EN  
 ▶ Refer to C02. S01. P18



Table 1a — Solutions to satisfy the requirements of BS EN 1364-1: 1999



**60 / 72 combination**

Two rows of Gypframe 60 I 70 'I' Studs in Gypframe 72 FEC 50 Folded Edge Standard Floor & Ceiling Channel. Gypframe SC1 Spacer Clips and alternate studs staggered in the channel at 300mm centres. Linings and insulation as in table.

**92 / 148 combination**

Two rows of Gypframe 92 I 90 'I' Studs in Gypframe 148 DC 60 Deep Flange Floor & Ceiling Channel. Gypframe SC2 Spacer Clips and alternate studs staggered in the channel at 300mm centres. Linings and insulation as in table.

**60 / 72 combination**

Two rows of Gypframe 60 I 70 'I' Studs in Gypframe 72 FEC 50 Folded Edge Standard Floor & Ceiling Channel. Gypframe SC1 Spacer Clips and alternate studs staggered in the channel at 300mm centres. Linings and insulation as in table.

**92 / 148 combination**

Two rows of Gypframe 92 I 90 'I' Studs in Gypframe 148 DC 60 Deep Flange Floor & Ceiling Channel. Gypframe SC2 Spacer Clips and alternate studs staggered in the channel at 300mm centres. Linings and insulation as in table.

Detail	Partition thickness mm	Board type mm	Lining thickness mm	Max. partition height <sup>1</sup> mm	Sound insulation $R_w (R_w + C_{tr})$ dB			Duty rating	Approx. weight kg/m <sup>2</sup>	System reference	
					25mm <sup>2</sup> any finish <sup>3</sup>	50mm <sup>2</sup> any finish <sup>3</sup>	25mm <sup>2</sup> skim only <sup>4</sup>			Any finish <sup>3</sup>	Skim only <sup>4</sup>
<b>30 minutes fire resistance (EN)</b>											
①	102	Gyproc SoundBloc	1 x 15	3300	49	52	-	Heavy	28	A233001/021	-
②	178	Gyproc SoundBloc	1 x 15	5400	53	54	54	Heavy	28	A233006/026	A233006S
<b>60 minutes fire resistance (EN)</b>											
③	122	Gyproc SoundBloc	2 x 12.5	3600	57	59 (48)	-	Severe	44	A233002/022	-
④	198	Gyproc SoundBloc	2 x 12.5	5700	61 (51)	62 (53) <sup>5</sup>	-	Severe	44	A233007/027	-
<b>90 minutes fire resistance (EN)</b>											
③	132	Gyproc SoundBloc	2 x 15	3900	59 (49)	61 (53) <sup>5</sup>	-	Severe	53	A233003/023	-
④	208	Gyproc SoundBloc	2 x 15	5000	62 (54) <sup>5</sup>	63 (55) <sup>5</sup>	63 (54) <sup>5</sup>	Severe	53	A233008/028	A233008S

▶ For further assistance in choosing the right solution for your project, try our System Selector; an online tool that enables quick and easy filtering by performance criteria. It provides system specific information downloads including BIM (Revit) objects. Go to [gyproc.ie](http://gyproc.ie)

<sup>1</sup> The maximum heights quoted are limited by the fire state field of application or by limiting deflection of L/240 at 200 Pa, whichever is the more onerous.

<sup>2</sup> Isover Acoustic Roll insulation.

<sup>3</sup> Sound insulation performance for partitions finished using jointing or plaster skim.

<sup>4</sup> Sound insulation performance for partitions finished with a 2mm skim finish of Gyproc Finish Plasters.

<sup>5</sup> These Gyproc Approved Systems are designed to achieve minimum  $D_{nT,w} + C_{tr}$  45dB, subject to Pre-Completion Testing (Refer to Partitions introduction C04. S01. P109 – table 1)

**(NB)** The fire resistance and sound insulation performances are for imperforate partitions, walls and ceilings incorporating boards with all joints taped and filled, or skimmed according to Gyproc's recommendations. The quoted performances are achieved only if Gyproc and Isover components are used throughout, and the Company's fixing recommendations are strictly observed. Any variation in the specifications should be checked with Gyproc.

**(NB)** For heights between 4200mm and 8000mm, Gypframe Deep Flange Floor & Ceiling Channel should be used at base and at head (subject to deflection criteria).

# GypWall STAGGERED performance (continued)

## 60 / 72 and 92 / 148 combinations

For details of when to specify fire resistance using BS  
 ▶ Refer to C02. S01. P18



Table 1b — Solutions to satisfy requirements of BS 476: Part 22: 1987

①	②	③	④
<b>60 / 72 combination</b>	<b>92 / 148 combination</b>	<b>60 / 72 combination</b>	<b>92 / 148 combination</b>
Two rows of Gypframe 60 I 70 'I' Studs in Gypframe 72 FEC 50 Folded Edge Standard Floor & Ceiling Channel. Gypframe SC1 Spacer Clips and alternate studs staggered in the channel at 300mm centres. Linings and insulation as in table.	Two rows of Gypframe 92 I 90 'I' Studs in Gypframe 148 DC 60 Deep Flange Floor & Ceiling Channel. Gypframe SC2 Spacer Clips and alternate studs staggered in the channel at 300mm centres. Linings and insulation as in table.	Two rows of Gypframe 60 I 70 'I' Studs in Gypframe 72 FEC 50 Folded Edge Standard Floor & Ceiling Channel. Gypframe SC1 Spacer Clips and alternate studs staggered in the channel at 300mm centres. Linings and insulation as in table.	Two rows of Gypframe 92 I 90 'I' Studs in Gypframe 148 DC 60 Deep Flange Floor & Ceiling Channel. Gypframe SC2 Spacer Clips and alternate studs staggered in the channel at 300mm centres. Linings and insulation as in table.

Detail	Partition thickness mm	Board type mm	Lining thickness mm	Max. partition height <sup>1</sup> mm	Sound insulation $R_w (R_w + C_{tr})$ dB			Duty rating	Approx. weight kg/m <sup>2</sup>	System reference	
					25mm <sup>2</sup> any finish <sup>3</sup>	50mm <sup>2</sup> any finish <sup>3</sup>	25mm <sup>2</sup> skim only <sup>4</sup>			Any finish <sup>3</sup>	Skim only <sup>4</sup>
<b>30 minutes fire resistance (BS)</b>											
①	102	Gyproc SoundBloc	1 x 15	3300	49	52	-	Heavy	28	A233001/021	-
②	178	Gyproc SoundBloc	1 x 15	5400	53	54	54	Heavy	28	A233006/026	A2330065
<b>60 minutes fire resistance (BS)</b>											
③	122	Gyproc SoundBloc	2 x 12.5	3600	57	59 (48)	-	Severe	44	A233002/022	-
④	198	Gyproc SoundBloc	2 x 12.5	5700	61 (51)	62 (53) <sup>5</sup>	-	Severe	44	A233007/027	-
<b>90 minutes fire resistance (BS)</b>											
③	132	Gyproc SoundBloc	2 x 15	3900	59 (49)	61 (53) <sup>5</sup>	-	Severe	53	A233003/023	-
④	208	Gyproc SoundBloc	2 x 15	5800	62 (54) <sup>5</sup>	63 (55) <sup>5</sup>	63 (54) <sup>5</sup>	Severe	53	A233008/028	A2330085

▶ For further assistance in choosing the right solution for your project, try our System Selector; an online tool that enables quick and easy filtering by performance criteria. It provides system specific information downloads including BIM (Revit) objects. Go to [gyproc.ie](http://gyproc.ie)

<sup>1</sup>Based on a limiting deflection of L/240 at 200 Pa.

<sup>2</sup>Isover Acoustic Roll insulation.

<sup>3</sup>Sound insulation performance for partitions finished using jointing or plaster skim.

<sup>4</sup>Sound insulation performance for partitions finished with a 2mm skim finish of Gyproc Finish Plasters.

<sup>5</sup>These Gyproc Approved Systems are designed to achieve minimum  $D_{nT,w} + C_{tr}$  45dB, subject to Pre-Completion Testing (Refer to Partitions introduction C04. S01. P109 – table 1)

**NB** The fire resistance and sound insulation performances are for imperforate partitions, walls and ceilings incorporating boards with all joints taped and filled, or skimmed according to Gyproc's recommendations. The quoted performances are achieved only if Gyproc and Isover components are used throughout, and the Company's fixing recommendations are strictly observed. Any variation in the specifications should be checked with Gyproc.

**NB** For heights between 4200mm and 8000mm, Gypframe Deep Flange Floor & Ceiling Channel should be used at base and at head (subject to deflection criteria).

# GypWall STAGGERED design

## Building design

GypWall STAGGERED comprises two rows of Gypframe 'I' Studs at 600mm centres (offset 300mm) installed within Gypframe Floor & Ceiling Channels and held in position with Gypframe SC1 or Gypframe SC2 Spacer Clips. Gypframe SC1 Spacer Clips are used in conjunction with 60 / 72 combination, whereas Gypframe SC2 Spacer Clips are used conjunction with 92 / 148 combination.

## Planning – key factors

The position of services and heavy fixtures should be pre-determined and their installation planned into the frame erection stage.

## Fixing floor and ceiling channels

Gypframe Floor & Ceiling Channels must be securely fixed with a row of fixings at 600mm maximum centres. For 148mm channels, two rows of staggered fixings are required, each row at 600mm centres and each fixing 25mm in from the flange. If the floor is uneven, a 38mm thick timber sole plate equal to the width of the channel should be used.

If the concrete or screeded floor is new, consideration should be given to the installation of a damp-proof membrane between the floor surface and the channel or sole plate.

## Splicing

To extend studs, overlap by 600mm (minimum). Fix together using Gyproc Wafer Head Jack-Point Screws or steel pop rivets (two to each flange).

► Refer to Partitions introduction C04. S01. P110 – construction detail 1.

## Partition to structural steelwork junctions

When designing the layout of rooms requiring separation by sound insulating walls abutting structural steelwork, consideration should be given to the potential loss of sound insulation performance through the steelwork.

► Refer to C02. S01. P21 – Building acoustics.

## Door openings

Any openings will require careful detailing if the acoustic performance of the partition is to be maintained. Specialist heavy acoustic doorsets may require additional support.

The designer should consider thickness tolerances of the partition types in relation to the proposed door frame detail. Standard door frame detailing to satisfy BS 5234 requirements for Heavy and Severe Duty Ratings is shown in Partitions introduction C04. S01. P119 – construction detail 26. Additional provision is required to support heavy doorsets. The door manufacturer should also be consulted in relation to door details.



## Important information

For partition heights above 4200mm, Gypframe Deep Flange Floor & Ceiling Channels should be used.

## Framing surround for openings

Where services such as horizontal ducts, fire dampers and access panels are required to penetrate the wall, their position should be pre-determined in order that a framed opening can be provided. The openings should be constructed using established metal stud procedures.

► Refer to Partitions introduction C04. S01. P121 - construction details 28-31.

## Cavity fire barriers

Where required to maintain fire performance, suitable fire stopping (by others) should be installed full filled within the partition cavity to form a suitable closure.

## Acoustic performance

The partition achieves high levels of sound insulation by virtue of the separation between the two rows of studs. It is important that this isolation is maintained, and that services, fixtures, etc, do not form a bridge between the two linings.

► Refer to C02. S01. P21 – Building acoustics.

## Deflection heads

Performance details apply to fixed head constructions. Partition head deflection designs may be necessary to accommodate deflections in the supporting floor. Deflection heads may also be required to the underside of roof structures subjected to positive and negative pressures.

The partitions can incorporate head deflection designs to optimise sound insulation performance.

► Refer to construction details 2 and 3.

## Services

### Penetrations

Penetrations of fire-resistant or sound-insulating constructions for services need careful consideration to ensure that the performance of the element is not downgraded. Consideration also needs to be given to the services themselves so they do not act as the mechanism of fire spread or sound transmission.

► Refer to C02. S01. P41 – Service installations.

### Electrical

The installation of electrical services should be carried out in accordance with BS 7671. The cut-outs in the studs can be used for routing electrical and other small services.

► Refer to Partitions introduction C04. S01. P110 – construction detail 2.

## GypWall STAGGERED design (continued)

Switch boxes and socket outlets can be supported from Gypframe 99 FC 50 Fixing Channel fixed horizontally between studs, or a high performance socket box detail used where higher acoustic performance is required.

Cables should be protected by conduit, or other suitable precautions taken to prevent abrasion when they pass through the metal frame. Service cut-outs should be aligned to allow easy installation of service. If studs require cutting, cut from the same end of each stud to ensure cut-out alignment.

► Refer to C02. S01. P41 – Service installations.

### Independent support

When designing for the installation of services such as fire dampers and associated ductwork through a GypWall partition, consideration should be given to the size and weight of the damper - this will determine whether it can be supported directly from the partition or needs to be independently supported from the structure.

► Refer to Partitions introduction C04. S01. P122 – construction details 29-31.

### Fixtures

Lightweight fixtures can be made directly to the partitions. Medium weight fixtures can be made to Gypframe 99 FC 50 Fixing Channel. Heavyweight fixtures (to BS 5234), such as wash basins and wall cupboards, can be fixed using plywood secured with Gypframe Service Support Plates (suitable for 92/148 framing combination only).

► Refer to C02. S01. P41 – Service installations

### Board finishing

► Refer to C08. S01. P483 – Finishes.

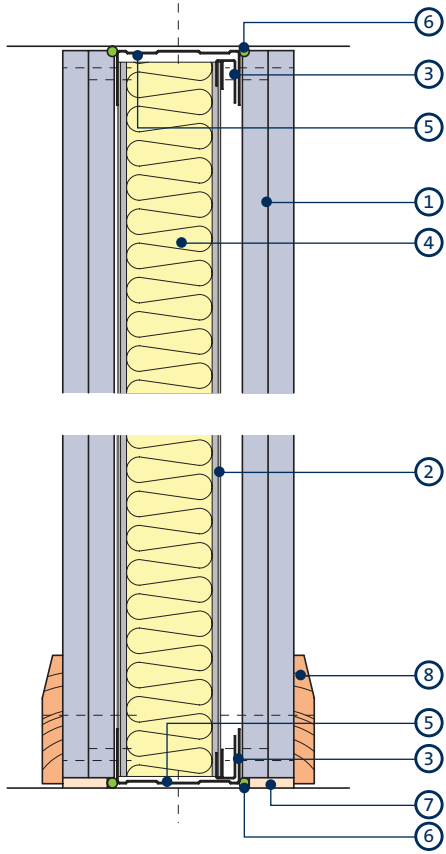
### Tiling

Tiles can be applied to the surface of lightweight partition systems.

► Refer to C08. S04. P498 – Tiling

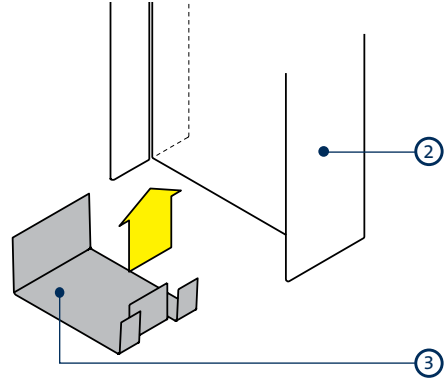
# GypWall STAGGERED construction details

1



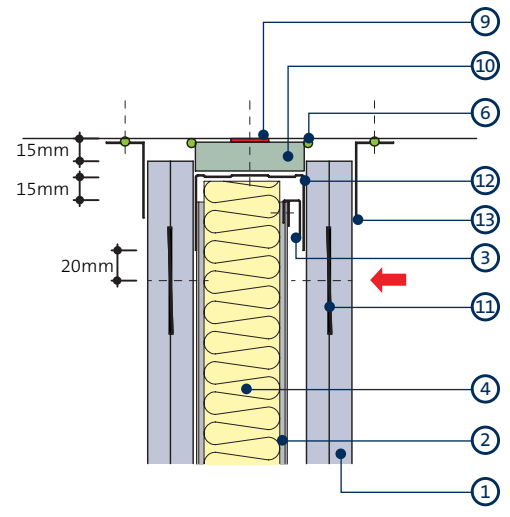
Head and base

4



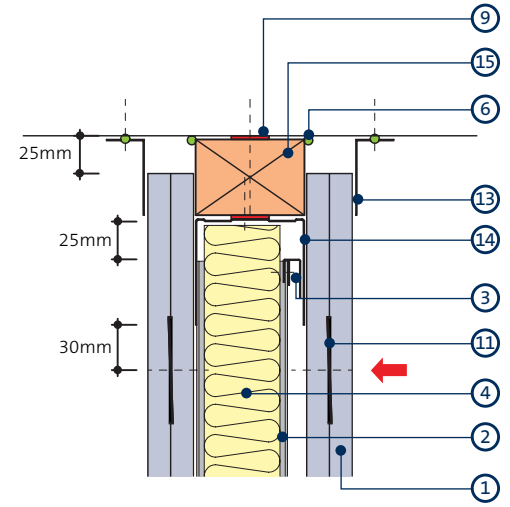
Clip attachment

2



Deflection head for 15mm downward movement and 60 minutes fire resistance - BS 476 Part 22: 1987

3



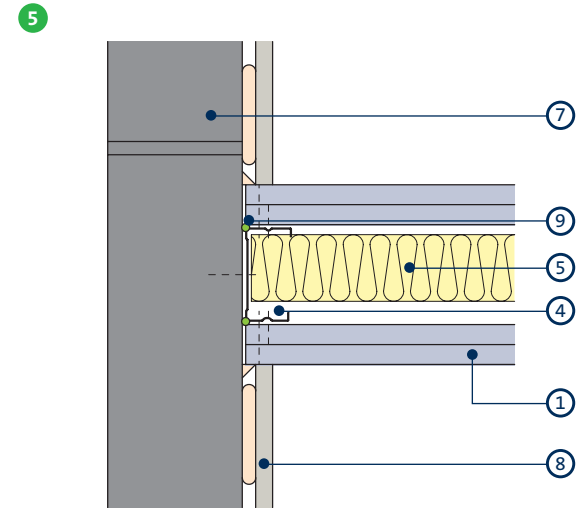
Deflection head for ± 25mm movement and 60 minutes fire resistance - BS 476 Part 22: 1987

- 1 Gyproc SoundBloc
- 2 Gyproframe 'I' Stud
- 3 Gyproframe Spacer Clip
- 4 Isover Acoustic Roll
- 5 Gyproframe Floor & Ceiling Channel
- 6 Gyproc Sealant
- 7 Bulk fill with Gyproc jointing materials (where gap exceeds 5mm)
- 8 Skirting

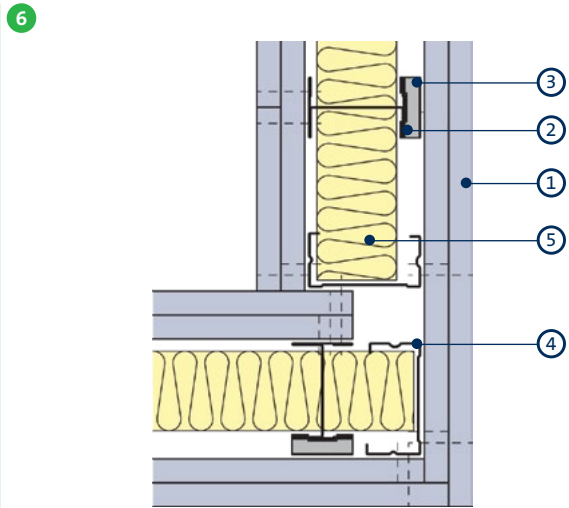
- 9 Gyproc FireStrip
- 10 Gyproc CoreBoard or Glasroc F FIRECASE
- 11 Gyproframe GFS1 Fixing Strap
- 12 Gyproframe Deep Flange Floor & Ceiling Channel suitably fixed through fire-stop to structure
- 13 Gyproframe Steel Angle
- 14 Gyproframe Extra Deep Flange Floor & Ceiling Channel fixed to timber head plate
- 15 Timber head plate suitably fixed to structure

**NB** No fixings should be made through the boards into the flanges of the head channel. The arrow (←) denotes the uppermost board fixing, which should be made into Gyproframe GFS1 Fixing Strap. Continuous Gyproc FireStrip must be installed as shown in order to maintain fire performance. Gyproframe Steel Angle or approved decorative trim (by others) should be fixed to the soffit either side of the partition as shown to maintain the acoustic performance. Where ± deflection is a requirement, Gyproframe SC1 or SC2 Spacer Clips must be pre-fixed to the 'I' studs to avoid the risk of disengagement once deflection is taken up.

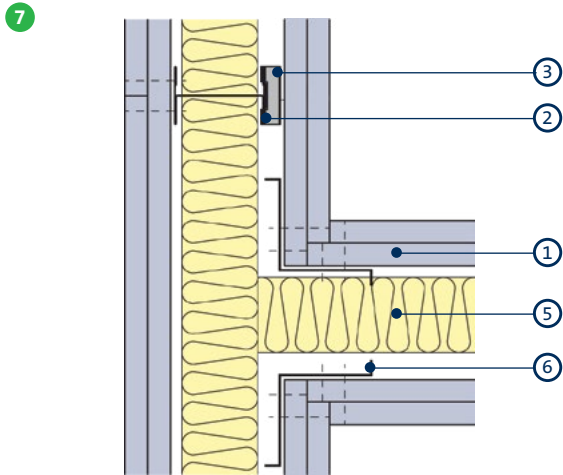
# GypWall STAGGERED construction details (continued)



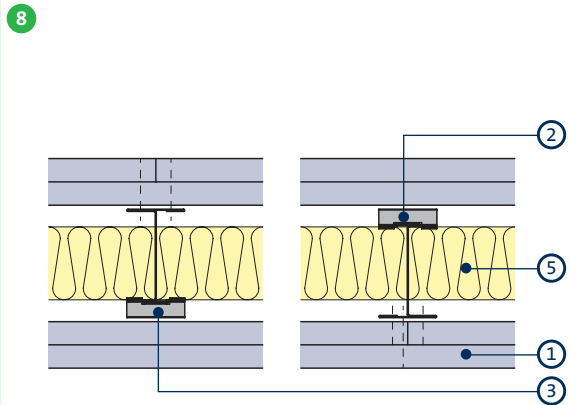
Junction with masonry



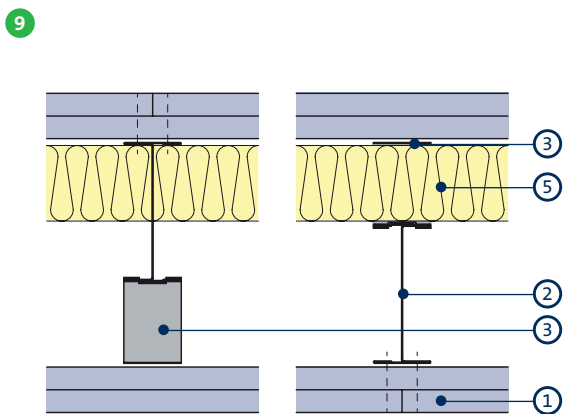
Corner



'T' junction



Intermediate studs (60 / 72 combination)



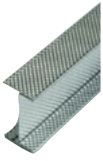
Intermediate studs (92 / 148 combination)

- 1 Gyproc SoundBloc
- 2 Gypframe 'T' Stud
- 3 Gypframe Spacer Clip
- 4 Gypframe 'C' Stud
- 5 Isover Acoustic Roll

- 6 Gypframe GA5 Internal Fixing Angle
- 7 Blockwork
- 8 Drilyner wall lining system
- 9 Gyproc Sealant

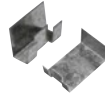
# GypWall STAGGERED system components

## Gypframe metal components



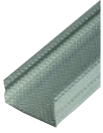
### Gypframe 'I' Studs (60 I 70, 92 I 90)

Enhanced strength stud that allows for partition height, without increasing partition width designed to receive fixing of board to one side only.



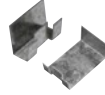
### Gypframe SC1 Spacer Clip

Clip to aid positioning and securing of Gypframe 60 I 70 'I' Studs.



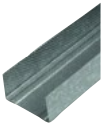
### Gypframe 'C' Studs (70 S 50, 146 S 50)

Vertical stud providing acoustic and structural performances designed to receive fixing of board. Used at abutments and openings.



### Gypframe SC2 Spacer Clip

Clip to aid positioning and securing of Gypframe 92 I 90 'I' Studs.



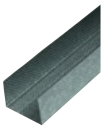
### Gypframe Folded Edge Standard Floor & Ceiling Channels (72 FEC 50, 148 FEC 50)

Standard floor and ceiling channels for retaining the Gypframe studs at floor and ceiling junctions and around openings to heights not exceeding 4200mm, whilst also containing Gypframe Spacer Clips.



### Gypframe 99 FC 50 Fixing Channel

A versatile metal fixing channel used to support medium weight fixtures on walls.



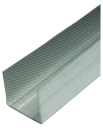
### Gypframe Deep Flange Floor & Ceiling Channels (72 DC 60, 148 DC 60)

Floor and ceiling channels with deep flanges for retaining the Gypframe studs at floor and ceiling junctions for partitions 4200mm to 8000mm high. Also used around openings and in deflection heads (maximum 30mm deflection), whilst also containing Gypframe Spacer Clips.



### Gypframe GF51 Fixing Strap

Used to support horizontal board joints, and within deflection heads.



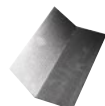
### Gypframe Extra Deep Flange Floor & Ceiling Channels (72 EDC 80, 148 EDC 80)

Floor and ceiling channels with extra deep flanges for retaining the Gypframe studs at floor and ceiling junctions for partitions over 8000mm high. Also used around openings and in deflection heads (maximum 50mm deflection), whilst also containing Gypframe Spacer Clips.



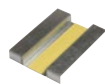
### Gypframe GA5 Internal Fixing Angle

Steel angle providing framing stability and board support.



### Gypframe GA6 Splayed Angle

Steel angle providing framing stability and board support.



### Gypframe Service Support Plate

For installation of 18mm plywood within a partition cavity to support medium to heavyweight fixtures with 92 / 148 combination.

## GypWall STAGGERED system components (continued)

### Board products



#### Gyproc SoundBloc<sup>1</sup>

Gypsum plasterboard with a high density core for enhanced sound insulation performance.



#### Glasroc F FIRECASE

Non-combustible glass-reinforced gypsum board. Used to form deflection head.



#### Gyproc DuraLine<sup>1</sup>

Gypsum plasterboard with fire resistant additives and a high density core for enhanced sound insulation and impact resistance performance.



#### Gyproc CoreBoard

Gypsum plasterboard with fire and moisture resistant additives. Used to form deflection head.

<sup>1</sup> Also available in a Moisture Resistant (MR) version. MR boards are specified in intermittent wet use areas.

### Fixing products



#### Gyproc Jack-Point Screws

Corrosion resistant self-tapping steel screws for fixing board to metal framing 0.8mm thick and greater ('I' studs 0.6mm thick and greater).



#### Gyproc Wafer Head Jack-Point Screws

Corrosion resistant self-tapping steel screws for fixing metal to metal framing 0.8mm thick and greater ('I' studs 0.6mm thick and greater).

### Plasterboard accessories



#### Gyproc Jointing Material

Jointing compounds, ready mixes and adhesives for reinforcement and finishing of board joints.



#### Gyproc Sealant

Used to seal air paths for optimum sound insulation.



#### Gyproc Paper Joint Tape

A paper tape designed for reinforcement of flat joints or internal angles.



#### Gyproc FireStrip

A soft extruded linear intumescent gap sealer to maintain fire resistance located directly to the underside of the soffit when forming a deflection head.



#### Gyproc Drywall Primer

Used to prepare for painting.  
Tub contents 10 litre

## Finishing products

---



### Gyproc Skimcoat

To provide a plaster skim finish on most common backgrounds including undercoat plasters and plasterboard. Can provide enhanced acoustic performance.



### Gyproc Carlite Finish

To provide a plaster skim finish on most common backgrounds including undercoat plasters and plasterboard. Can provide enhanced acoustic performance.



### Gyproc Carlite Ultra Finish

Offers all the benefits of Gyproc Skimcoat and Gyproc Carlite Finish with a reduced set time of 90-120mins, making it ideal for smaller jobs.



### Gyproc Magnetic Plaster

To provide a plaster skim finish that provides an attraction to magnets used to finish a wide range of backgrounds, including undercoat plasters and plasterboard.



### Plaster accessories

Designed for the reinforcement and finishing of board joints before plaster skimming.

## Insulation products

---



### Isover Acoustic Roll

Glass mineral wool for enhanced acoustic and thermal performance.

# GypWall STAGGERED installation overview

This is intended to be a basic description of how the system is built.



Gypframe Floor & Ceiling channels are suitably fixed to the floor and soffit.



Gypframe 'C' Studs are suitably fixed at abutments and door openings.



The perimeter of the partition is then sealed on both sides with Gyproc Sealant.



Gypframe SC1 or SC2 Spacer Clips are inserted to the top and bottom of the Gypframe 60 I 70 or 92 I 90 'I' Studs respectively.



The studs are then friction fitted into the Gypframe Channels, alternating the direction of the clip to create a staggered stud framework.



Door openings are constructed to the Heavy and Severe Duty rating door detail.



M&E services can be located within the partition cavity. Care should be taken to prevent bridging, for example socket boxes making contact with the opposing studs.



Isover Acoustic Roll is added to the partition cavity.



Gyproc SoundBloc plasterboards are then screw fixed to alternate Gypframe 'I' Studs and other framing members with Gyproc Jack-Point Screws.



## Additional information

For full installation details, refer to the [Gyproc Installation Guide](#), available to download from [gyproc.ie](#)

# GypWall QUIET

Twin frame high performance acoustic wall system

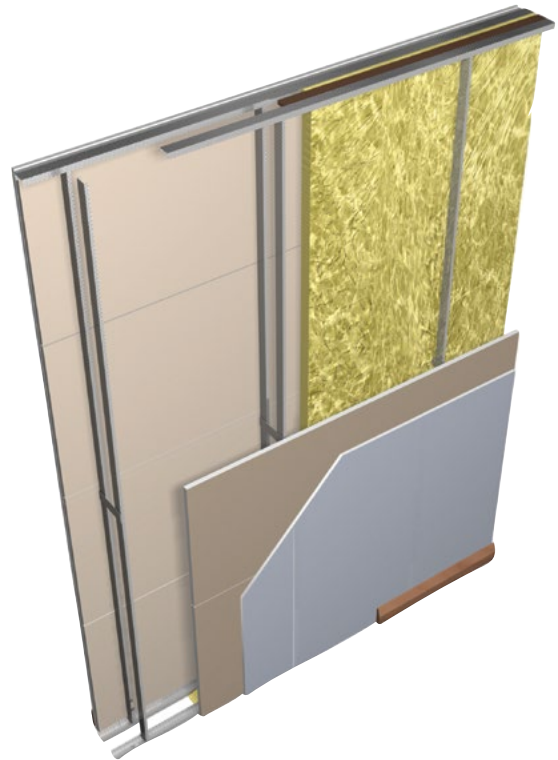
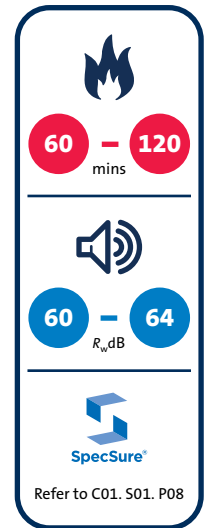


# GypWall QUIET

**GypWall QUIET** is a lightweight, non-loadbearing, twin framed acoustic separating wall, often used in developments such as apartments, hotels, hospitals and schools where a high level of acoustic performance is required to either meet or exceed Building Regulations.

## Key benefits

- GypWall QUIET can provide up to an estimated 90 minutes fire protection to structural steel enclosed within its cavity, whilst maintaining the room-to-room acoustic performance
- Twin-frame design allows services and structural steel to easily be accommodated within the partition
- Reduced sound transmission is achieved by a high degree of isolation between the two frameworks and the use of high performance Gyproc plasterboard linings
- Additional acoustic performance can be achieved with the application of Gyproc Finish Plasters



## You may also be interested in...

### GypWall QUIET IWL

Looking for an increase in acoustic performance? For example, if designing for a prestigious development or to achieve credits towards a BREEAM framework.

GypWall QUIET IWL provides greater levels of acoustic insulation, through the use of a totally isolated twin stud frameworks.

► Refer to C04. S08. P231 – GypWall QUIET IWL

# GypWall QUIET performance

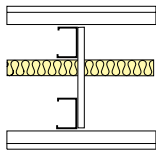
## 48mm Gypframe 'C' Studs with cross braces

For details of when to specify fire resistance using EN  
 ► Refer to C02. S01. P18



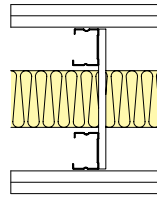
Table 1a — Solutions to satisfy the requirements of BS EN 1364-1: 1999

①



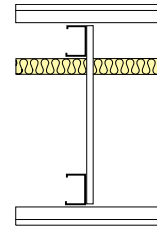
Two Gypframe 48 S 50 'C' Stud frameworks braced at max. 1200mm centres. Studs at 600mm centres. Isover Acoustic Roll in the cavity (cavity width 137mm). Linings and insulation as in table.

②



Two Gypframe 48 S 50 'C' Stud frameworks braced at max. 1200mm centres. Studs at 600mm centres. Isover Acoustic Slab in the cavity (cavity width 190mm). Linings and insulation as in table.

③



Two Gypframe 48 S 50 'C' Stud frameworks braced at max. 1200mm centres. Studs at 600mm centres. Isover Acoustic Roll in the cavity (cavity width 237mm). Linings and insulation as in table.

Detail	Partition thickness mm	Board type mm	Lining thickness mm	Max. partition height <sup>1</sup> mm	Insulation thickness mm	Sound insulation $R_w + C_{tr}$ dB		Duty rating	Approx. weight kg/m <sup>2</sup>	System reference	
						Any <sup>2</sup> finish	Skim <sup>3</sup> only			Any <sup>2</sup> finish	Skim <sup>3</sup> only
<b>60 minutes fire resistance</b> (EN)											
①	200	Gyproc Plank + Gyproc SoundBloc	1 x 19 + 1 x 12.5	6200	25	61 (47)	-	Severe	55	A216001	-
①	200	Gyproc SoundBloc	2 x 15	6200	50	62 (56) <sup>4</sup>	63 (56) <sup>4</sup>	Severe	55	A216009	A216009S
②	250	Gyproc SoundBloc	2 x 15	6200	75	63 (57) <sup>4</sup>	64 (57) <sup>4</sup>	Severe	55	A216011	A216011S
③	300	Gyproc Plank + Gyproc SoundBloc	1 x 19 + 1 x 12.5	6200	25	62 (52) <sup>4</sup>	-	Severe	55	A216002	-
③	300	Gyproc SoundBloc	2 x 15	6200	25	63 (57) <sup>4</sup>	64 (57) <sup>4</sup>	Severe	55	A216008	A216008S
<b>90 minutes fire resistance</b> (EN)											
①	200	Gyproc Plank + Gyproc SoundBloc	1 x 19 + 1 x 12.5	5000	25	61 (47)	-	Severe	55	A216001	-
②	250	Gyproc SoundBloc	2 x 15	5000	75	63 (57) <sup>4</sup>	64 (57) <sup>4</sup>	Severe	55	A216011	A216011S
③	300	Gyproc Plank + Gyproc SoundBloc	1 x 19 + 1 x 12.5	5000	25	62 (52) <sup>4</sup>	-	Severe	55	A216002	-
③	300	Gyproc SoundBloc	2 x 15	5000	100	64 (58) <sup>4</sup>	-	Severe	55	A216012	-
<b>120 minutes fire resistance</b> (EN)											
①	200	Gyproc FireLine	2 x 15	5000	50	60 (53) <sup>4</sup>	61 (53) <sup>4</sup>	Severe	52	A216010	A216010S

► For further assistance in choosing the right solution for your project, try our System Selector; an online tool that enables quick and easy filtering by performance criteria. It provides system specific information downloads including BIM (Revit) objects. Go to [gyproc.ie](http://gyproc.ie)

<sup>1</sup> The maximum heights quoted are limited by the fire state field of application or by limiting deflection of L/240 at 200 Pa, whichever is the more onerous.

<sup>2</sup> Sound insulation performance for partitions finished using jointing or plaster skim.

<sup>3</sup> Sound insulation performance for partitions finished with a 2mm skim finish of Gyproc Finish Plasters.

<sup>4</sup> These Gyproc Approved Systems are designed to achieve minimum  $D_{nT,w} + C_{tr}$  45dB, subject to Pre-Completion Testing (Refer to Partitions introduction C04. S01. P109 – table 1).

**(NB)** For heights above 4200mm Gypframe Deep Flange Floor & Ceiling Channel should be used at base and at head (subject to deflection criteria).

**(NB)** The fire resistance and sound insulation performances are for imperforate partitions, walls and ceilings incorporating boards with all joints taped and filled, or skimmed according to Gyproc's recommendations. The quoted performances are achieved only if Gyproc and Isover components are used throughout, and the Company's fixing recommendations are strictly observed. Any variation in the specifications should be checked with Gyproc.

# GypWall QUIET performance (continued)

## 48mm Gypframe 'C' Studs with cross braces

For details of when to specify fire resistance using BS  
 ► Refer to C02. S01. P18



Table 1b — Solutions to satisfy requirements of BS 476: Part 22: 1987

①	②	③
Two Gypframe 48 S 50 'C' Stud frameworks braced at max. 1200mm centres. Studs at 600mm centres. Isover Acoustic Roll in the cavity (cavity width 137mm). Linings and insulation as in table.	Two Gypframe 48 S 50 'C' Stud frameworks braced at max. 1200mm centres. Studs at 600mm centres. Isover Acoustic Slab in the cavity (cavity width 190mm). Linings and insulation as in table.	Two Gypframe 48 S 50 'C' Stud frameworks braced at max. 1200mm centres. Studs at 600mm centres. Isover Acoustic Roll in the cavity (cavity width 237mm). Linings and insulation as in table.

Detail	Partition thickness mm	Board type mm	Lining thickness mm	Max. partition height <sup>1</sup> mm	Insulation thickness mm	Sound insulation $R_w (R_w + C_{tr})$ dB		Duty rating	Approx. weight kg/m <sup>2</sup>	System reference	
						Any <sup>2</sup> finish	Skim <sup>3</sup> only			Any <sup>2</sup> finish	Skim <sup>3</sup> only
<b>90 minutes fire resistance</b> <span style="border: 1px solid black; border-radius: 50%; padding: 2px;">BS</span>											
①	200	Gyproc Plank + Gyproc SoundBloc	1 x 19 + 1 x 12.5	6200	25	61 (47)	-	Severe	55	A216001	-
①	200	Gyproc SoundBloc	2 x 15	7500	50	62 (56) <sup>4</sup>	63 (56) <sup>4</sup>	Severe	55	A216009	A216009S
②	250	Gyproc SoundBloc	2 x 15	7500	75	63 (57) <sup>4</sup>	64 (57) <sup>4</sup>	Severe	55	A216011	A216011S
③	300	Gyproc Plank + Gyproc SoundBloc	1 x 19 + 1 x 12.5	6200	25	62 (52) <sup>4</sup>	-	Severe	55	A216002	-
③	300	Gyproc SoundBloc	2 x 15	7500	25	63 (57) <sup>4</sup>	64 (57) <sup>4</sup>	Severe	55	A216008	A216008S
<b>120 minutes fire resistance</b> <span style="border: 1px solid black; border-radius: 50%; padding: 2px;">BS</span>											
①	200	Gyproc FireLine	2 x 15	7500	50	60 (53) <sup>4</sup>	61 (53) <sup>4</sup>	Severe	52	A216010	A216010S

► For further assistance in choosing the right solution for your project, try our System Selector; an online tool that enables quick and easy filtering by performance criteria. It provides system specific information downloads including BIM (Revit) objects. Go to [gyproc.ie](http://gyproc.ie)

<sup>1</sup> Based on limiting deflection of L/240 at 200 Pa.

<sup>2</sup> Sound insulation performance for partitions finished using jointing or plaster skim.

<sup>3</sup> Sound insulation performance for partitions finished with a 2mm skim finish of Gyproc Finish Plasters.

<sup>4</sup> These Gyproc Approved Systems are designed to achieve minimum  $D_{nT,w} + C_{tr}$  45dB, subject to Pre-Completion Testing (Refer to Partitions introduction C04. S01. P109 – table 1).

**NB** For heights above 4200mm Gypframe Deep Flange Floor & Ceiling Channel should be used at base and at head (subject to deflection criteria).

**NB** The fire resistance and sound insulation performances are for imperforate partitions, walls and ceilings incorporating boards with all joints taped and filled, or skimmed according to Gyproc's recommendations. The quoted performances are achieved only if Gyproc and Isover components are used throughout, and the Company's fixing recommendations are strictly observed. Any variation in the specifications should be checked with Gyproc.

For details of when to specify fire resistance using EN / BS  
 ▶ Refer to C02. S01. P18



**Table 2 — Solutions to satisfy requirements of ENV 13381-2: 2002 and BS 476: Part 21: 1987<sup>1</sup>**

Board type	Lining thickness mm	Fire resistance min	Section factor <sup>2</sup> A/V (Hp/A) m <sup>-1</sup>
Gyproc SoundBloc	2 x 12.5	30	Up to 300
Gyproc SoundBloc	2 x 15	60	Up to 300
Gyproc Plank + Gyproc SoundBloc	1 x 19 + 1 x 12.5	60	Up to 300
Gyproc FireLine	2 x 15	90	Up to 300

<sup>1</sup> Estimated fire protection to structural steelwork within this partition cavity.

<sup>2</sup> Based on four-sided exposure, with no vertical joints aligning with the column, and boards not fixed to the column to maintain air space (10mm for BS or 50mm for EN).

# GypWall QUIET design

## Building design

GypWall QUIET comprises twin row Gypframe 'C' Studs at 600mm centres within twin row Gypframe Floor & Ceiling Channels. For heights up to 2400mm each pair of studs must be cross braced at mid-height. Where multiple braces are required the braces must be located at 1200mm vertical centres staggered by 600mm.

## Planning — key factors

The position of services and heavy fixtures should be pre-determined and their installation planned into the frame erection stage. All penetrations will need to be adequately stopped for fire and acoustics.

## Fixing floor and ceiling channels

Gypframe Floor & Ceiling Channels must be securely fixed with a row of fixings at 600mm maximum centres. If the floor is uneven, a 38mm thick timber sole plate equal to the width of the channel should be used.

If the concrete or screeded floor is new, consideration should be given to the installation of a damp-proof membrane between the floor surface and the channel or sole plate.

## Splicing

To extend studs, overlap by 600mm (minimum). Fix together using Gyproc Wafer Head Drywall Screws or steel pop rivets (two to each flange).

► Refer to Partitions introduction C04. S01. P110 – construction detail 1.

## Partition to structural steelwork junctions

When designing the layout of rooms requiring separation by sound insulating walls abutting structural steelwork, consideration should be given to the potential loss of sound insulation performance through the steelwork.

► Refer to C02. S01. P21 – Building acoustics.

## Door openings

The designer should consider the thickness tolerances of the partition types in relation to the proposed door frame detail. To satisfy BS 5234 requirements for Heavy and Severe Duty partitions, door framing should be specified as shown in C04. S01. P119 – construction detail 26. The door manufacturer should also be consulted in relation to the door detail.

If a plastered finish is specified, the thickness of the door or glazing frame must allow for the thickness of the plaster finish.

## Cavity fire barriers

Where required to maintain fire performance, suitable fire stopping (by others) should be installed full filled within the partition cavity to form a suitable closure.

## Deflection heads

Partition head deflection designs may be necessary to accommodate deflections in the supporting floor. Deflection heads may also be required to the underside of roof structures subjected to positive and negative pressures.

Special detailing to minimise the loss of acoustic performance:

► Refer to C02. S01. P21 – Building acoustics.

For deflection head design refer to construction detail 2 within this section.

## Services

### Penetrations

Penetrations of fire-resistant or sound-insulating constructions for services need careful consideration to ensure that the performance of the element is not downgraded. Consideration also needs to be given to the services themselves so they do not act as the mechanism of fire spread or sound transmission.

► Refer to C02. S01. P41 – Service installations.

### Electrical

The installation of electrical services should be carried out in accordance with BS 7671. The cut-outs in the studs can be used for routing electrical and other small services (Partitions introduction C04. S01. P110 – construction detail 2). Switch boxes and socket outlets can be supported from Gypframe 99 FC 50 Fixing Channel fixed horizontally between studs, or a high performance socket box detail used where higher acoustic performance is required.

### Independent support

When designing for the installation of services such as fire dampers and associated ductwork through a GypWall partition, consideration should be given to the size and weight of the damper - this will determine whether it can be supported directly from the partition or needs to be independently supported from the structure.

► Refer to Partitions introduction C04. S01. P122 – construction details 29-31.

### Fixtures

Lightweight fixtures can be made directly to the partitions. Medium weight fixtures can be made to Gypframe 99 FC 50 Fixing Channel. Heavyweight fixtures (to BS 5234), such as wash basins and wall cupboards, can be fixed using plywood secured with Gypframe Service Support Plates.

► Refer to C02. S01. P41 – Service installations.

### Board finishing

► Refer to C08. S01. P483 – Finishes.

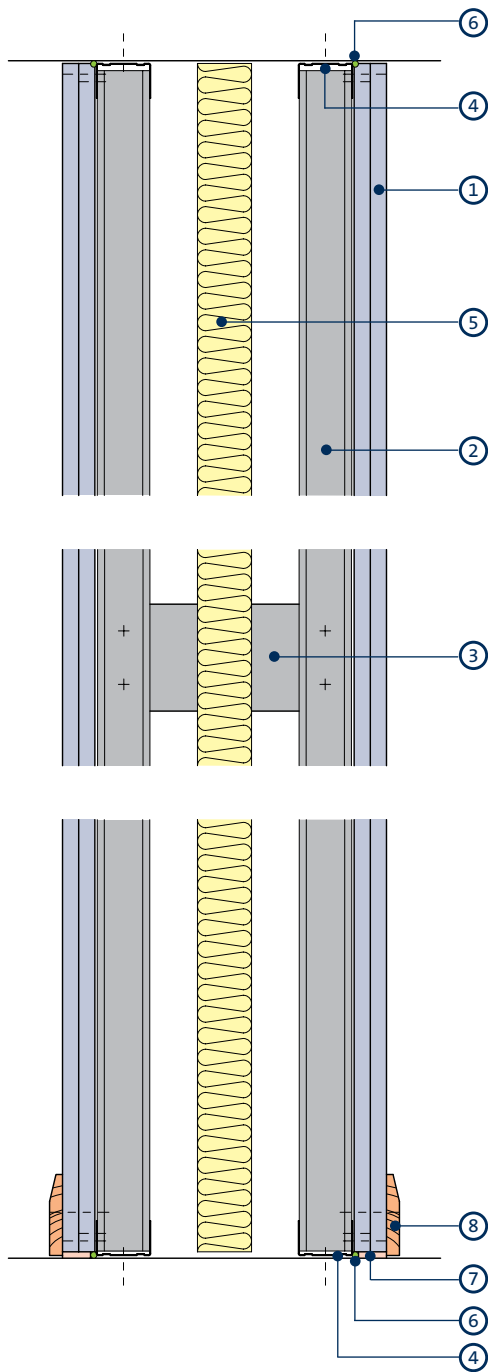
### Tiling

Tiles can be applied to the surface of lightweight partition systems.

► Refer to C08. S04. P498 – Tiling

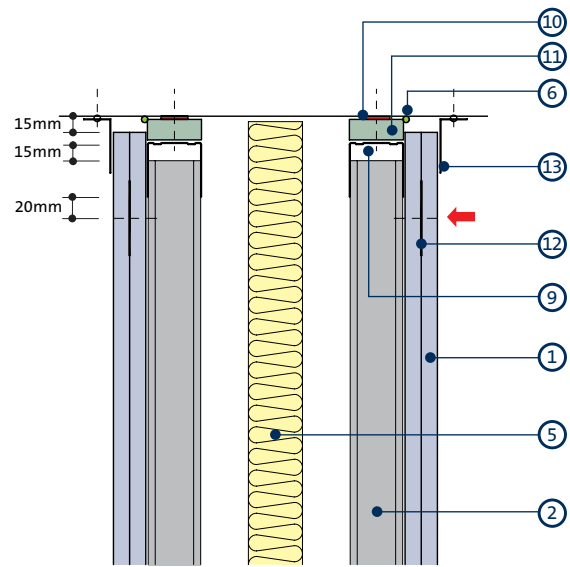
# GypWall QUIET construction details

1



Head and base

2



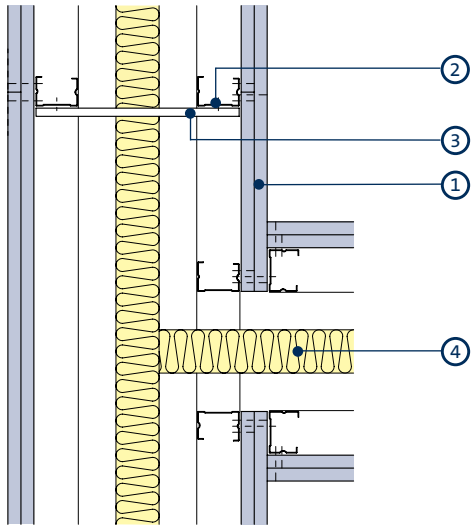
Deflection head for 15mm downward movement and 60 minutes fire resistance - BS 476 Part 22: 1987

- 1 Gyproc plasterboard
- 2 Gypframe 'C' Stud
- 3 Gypframe 99 FC 50 Fixing Channel (at 1200mm vertical centres)
- 4 Gypframe Folded Edge Standard Floor & Ceiling Channel
- 5 Isover insulation suitably supported at head
- 6 Gyproc Sealant
- 7 Bulk fill with Gyproc jointing materials (where gap exceeds 5mm)

- 8 Skirting
- 9 Gypframe Deep Flange Floor & Ceiling Channel suitable fixed through fire-stop to structure
- 10 Gyproc FireStrip
- 11 Gyproc CoreBoard or Glasroc F FIRECASE
- 12 Gypframe GFS1 Fixing Strap
- 13 Gypframe Steel Angle

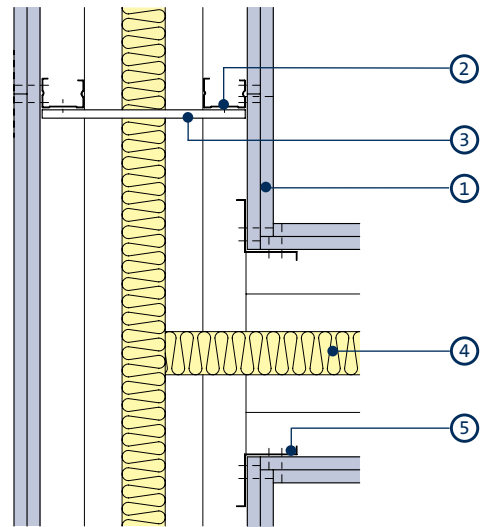
**NB** No fixings should be made through the boards into the flanges of the head channel. The arrow (←) denotes the position of the uppermost board fixing, which should be made into Gypframe GFS1 Fixing Strap (or stud nogging in C04. S01. P116 – construction detail 16). Continuous Gyproc FireStrip must be installed as shown to maintain fire performance. Where there is a need for a deflection head in a 90 minute wall, the 120 minute solution can be used (refer to Partitions introduction C04. S01. P116 – construction detail 16) or alternatively, please contact the Gyproc Technical Department for further guidance.

3



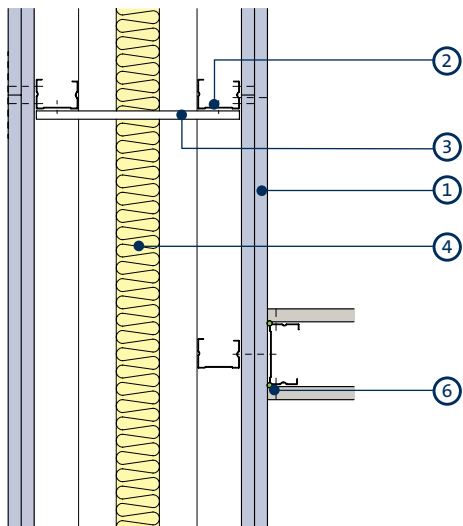
'T' Junction

4



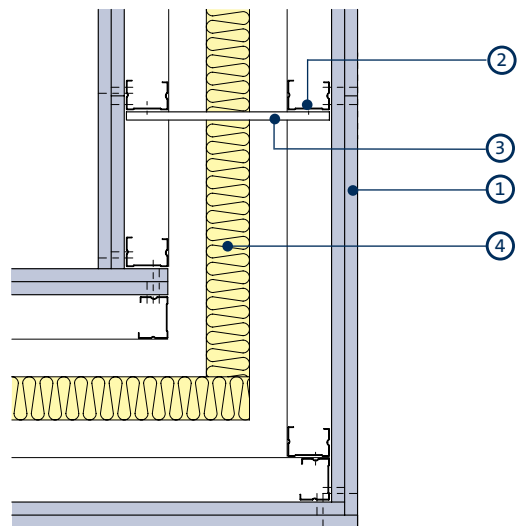
Alternative 'T' junction with Gypframe GA5 Internal Fixing Angle

5



'T' junction with GypWall partition

6



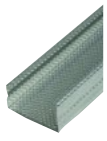
Internal / external corner

- 1 Gyproc plasterboard
- 2 Gypframe 'C' Stud
- 3 Gypframe 99 FC 50 Fixing Channel

- 4 Isover insulation
- 5 Gypframe GA5 Internal Fixing Angle
- 6 Gyproc Sealant

# GypWall QUIET system components

## Gypframe metal components



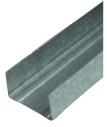
### Gypframe 'C' Studs (48 S 50)

Vertical stud providing acoustic and structural performances designed to receive fixing of board to one side along with a suitable Gyproc brace fixed to the other side.



### Gypframe GFS1 Fixing Strap

Used to support horizontal board joints.



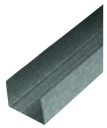
### Gypframe Folded Edge Standard Floor & Ceiling Channels (50 FEC 50)

Standard floor and ceiling channels for retaining the Gypframe studs at floor and ceiling junctions and around openings to heights not exceeding 4200mm.



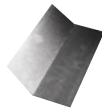
### Gypframe GA5 Internal Fixing Angle

Steel angle providing framing stability and board support.



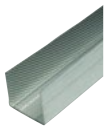
### Gypframe Deep Flange Floor & Ceiling Channels (50 DC 60)

Floor and ceiling channels with deep flanges for retaining the Gypframe studs at floor and ceiling junctions for partitions 4200mm to 8000mm high. Also used around openings and in deflection heads (maximum 30mm deflection).



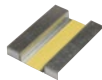
### Gypframe GA6 Splayed Angle

Steel angle providing framing stability and board support.



### Gypframe Extra Deep Flange Floor & Ceiling Channels (50 EDC 70)

Floor and ceiling channels with extra deep flanges for retaining the Gypframe studs at floor and ceiling junctions for partitions over 8000mm high. Also used around openings and in deflection heads (maximum 50mm deflection).



### Gypframe Service Support Plate

For installation of 18mm plywood within a partition cavity to support medium to heavyweight fixtures.



### Gypframe 99 FC 50 Fixing Channel

A versatile metal fixing channel used to support medium weight fixtures on walls. Also used to cross-brace the two rows of Gypframe stud.

## Board products



### Gyproc SoundBloc<sup>1</sup>

Gypsum plasterboard with a high density core for enhanced sound insulation performance.



### Gyproc Duraline<sup>1</sup>

Gypsum plasterboard with fire resistant additives and a high density core for enhanced sound insulation and impact resistance performance.



### Gyproc FireLine<sup>1</sup>

Gypsum plasterboard with fire resistant additives.



### Glasroc F FIRECASE

Non-combustible glass-reinforced gypsum board used to form deflection head.



### Gyproc Plank

Standard gypsum plasterboard located as an inner layer.



### Gyproc CoreBoard

Gypsum plasterboard with fire and moisture resistant additives used to form deflection head.

<sup>1</sup> Also available in a Moisture Resistant (MR) version. MR boards are specified in intermittent wet use areas.

## GypWall QUIET system components (continued)

### Fixing products



#### Gyproc Drywall Screws

Corrosion resistant self-tapping steel screws for fixing board-to-timber and board-to-metal framing less than 0.8mm thick.



#### Gyproc Wafer Head Drywall Screws

Corrosion resistant self-tapping steel screws for fixing metal to metal framing less than 0.8mm thick.



#### Gyproc Collated Drywall Screws

Corrosion resistant self-tapping steel screws for fixing board-to-timber and board-to-metal framing less than 0.8mm thick.

### Plasterboard accessories



#### Gyproc Jointing Materials

Jointing compounds, ready mixes and adhesives for reinforcement and finishing of board joints.



#### Gyproc FireStrip

A soft extruded linear intumescent gap sealer to maintain fire resistance located directly to the underside of the soffit when forming a deflection head.



#### Gyproc Control Joint

To accommodate structural movement of up to 7mm.



#### Gyproc Sealant

Used to seal air paths for optimum sound insulation.



#### Gyproc Drywall Primer

Used to prepare for painting. Tub contents 10 litre



#### Gyproc Paper Joint Tape

A paper tape designed for reinforcement of flat joints or internal angles.

### Finishing products



#### Gyproc Skimcoat

To provide a plaster skim finish on most common backgrounds including undercoat plasters and plasterboard. Can provide enhanced acoustic performance.



#### Gyproc Carlite Finish

To provide a plaster skim finish on most common backgrounds including undercoat plasters and plasterboard. Can provide enhanced acoustic performance.



#### Gyproc Carlite Ultra Finish

Offers all the benefits of Gyproc Skimcoat and Gyproc Carlite Finish with a reduced set time of 90-120mins, making it ideal for smaller jobs.



#### Gyproc Magnetic Plaster

To provide a plaster skim finish that provides an attraction to magnets used to finish a wide range of backgrounds, including undercoat plasters and plasterboard.



#### Plaster accessories

Designed for the reinforcement and finishing of board joints before plaster skimming.

## GypWall QUIET system components (continued)

### Insulation products

---



#### **Isover Acoustic Roll**

Glass mineral wool for enhanced acoustic and thermal performance.



#### **Isover Acoustic Slab**

Glass mineral wool to achieve acoustic performance.

---

# GypWall QUIET installation overview

This is intended to be a basic description of how the system is built.



Gyproframe Floor & Ceiling Channels are suitably fixed to the floor and soffit in two rows.



Gyproframe 'C' Studs are suitably fixed to abutments in two rows.



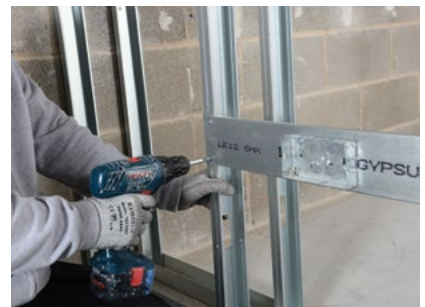
The perimeter of each frame is then sealed with Gyproc Sealant.



Gyproframe 'C' Studs are then friction fitted into the Gyproframe Floor & Ceiling Channels at the required centres. Door openings are constructed to the Heavy and Severe Duty Rating door detail.



The two frameworks are braced with Gyproframe 99 FC 50 Fixing Channel attached to the Gyproframe 'C' Studs with Gyproc Wafer Head Drywall Screws, two screws per junction.



Mechanical and electrical services can be located within the partition cavity.



Isover insulation is added to the partition cavity for increased acoustic performance.



Gyproc plasterboards are then fixed to the Gyproframe framework with Gyproc Drywall Screws.



## Additional information

For full installation details, refer to the **Gyproc Installation Guide**, available to download from [gyproc.ie](http://gyproc.ie)

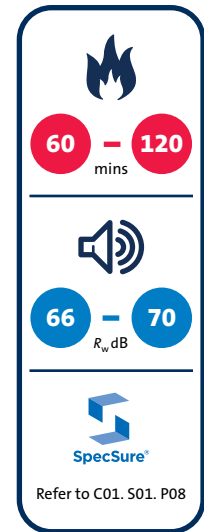
# GypWall QUIET IWL

Independent twin frame high performance acoustic separating wall system



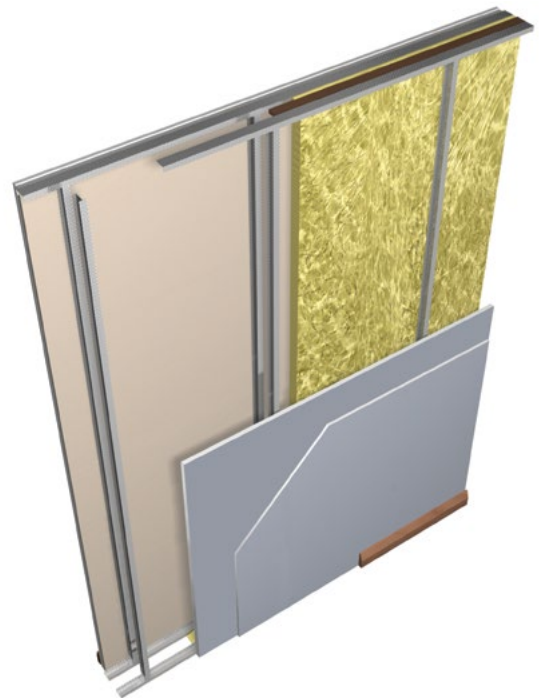
## GypWall QUIET IWL

GypWall QUIET IWL is a lightweight, non-loadbearing high performance wall. The use of an unbraced twin-frame ensures optimal acoustic isolation, providing an enhanced specification for buildings that are targeting higher standards of health and well-being, for example those designed to BREEAM frameworks or premium developments.



### Key benefits

- GypWall QUIET IWL is an approved Robust Detail specification E-WS-2 (England & Wales)
- Structural columns can be accommodated within the partition due to the twin-frame design
- GypWall QUIET IWL can provide up to an estimated 120 minutes fire protection to structural steel enclosed within its cavity
- Optimal resistance to impact noise transference between adjacent spaces is achieved as a result of the system's unbraced construction



### You may also be interested in...

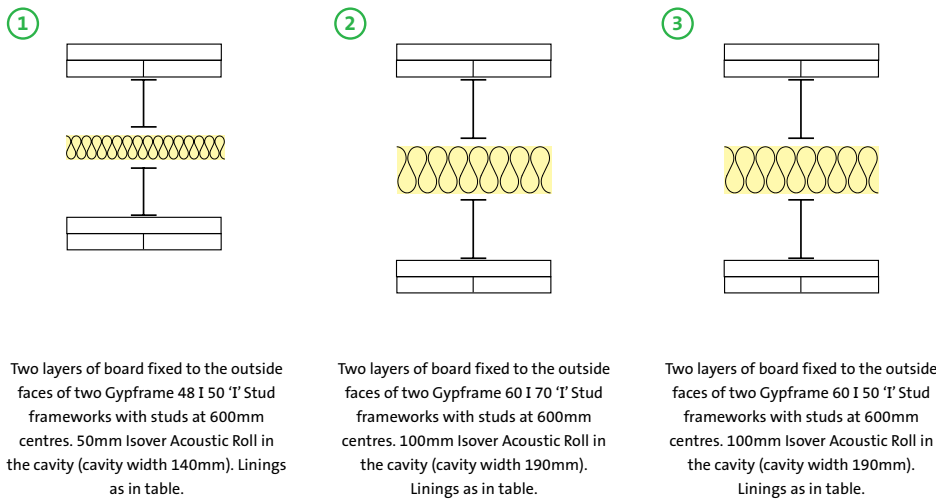
#### GypWall AUDIO

If you are looking for solutions with an even higher acoustic performance.

► Refer to C04, S09, P245 – GypWall AUDIO.



Table 1a — Solutions to satisfy requirements of BS EN 1364-1: 1999



Detail	Partition thickness mm	Board type	Lining thickness mm	Max. partition height <sup>1</sup> mm	Sound insulation $R_w (R_w + C_{tr})^2$ dB	Duty rating	Approx. weight kg/m <sup>2</sup>	System reference
<b>90 minutes fire resistance</b>								
①	200	Gyproc SoundBloc	2 x 15	2800	66 (58)	Severe	55	A216014
②	250	Gyproc SoundBloc	2 x 15	3900	RD <sup>4</sup>	Severe	55	A216007
③	250	Gyproc SoundBloc	2 x 15	3300	70 (62) / RD <sup>4</sup>	Severe	55	A216013
<b>120 minutes fire resistance</b>								
①	200	Gyproc DuraLine	2 x 15	2800	67 (58)	Severe	60	X216011

► For further assistance in choosing the right solution for your project, try our System Selector; an online tool that enables quick and easy filtering by performance criteria. It provides system specific information downloads including BIM (Revit) objects. Go to [gyproc.ie](http://gyproc.ie)

<sup>1</sup> The maximum heights quoted are limited by the fire state field of application or by limiting deflection of L/240 at 200 Pa, whichever is more onerous.

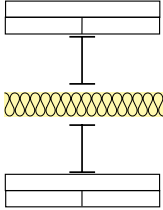
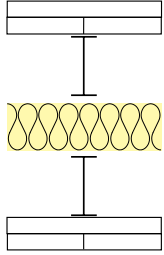
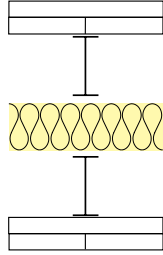
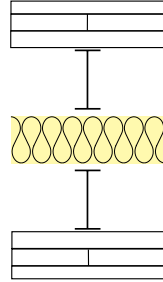
<sup>2</sup> These Gyproc Approved Systems are designed to achieve minimum  $D_{nT,w} + C_{tr}$  45dB, subject to Pre-Completion Testing (Refer to Partitions introduction C04. S01. P109 – table 1)

<sup>3</sup> RD = Robust Detail E-WS-2 (England and Wales) - approved Robust Detail solution designed to achieve minimum  $D_{nT,w} + C_{tr}$  45dB. Minimum 60mm Gypframe 'I' Studs required.

The fire resistance and sound insulation performances are for imperforate partitions, walls and ceilings incorporating boards with all joints taped and filled, or skimmed according to Gyproc's recommendations. The quoted performances are achieved only if Gyproc and Isover components are used throughout, and the company's fixing recommendations are strictly observed. Any variation in the specification should be checked with Gyproc.



Table 1b — Solutions to satisfy requirements of BS 476: Part 22: 1987

<p>①</p>  <p>Two layers of board fixed to the outside faces of two Gypframe 48 I 50 'I' Stud frameworks with studs at 600mm centres. 50mm Isover Acoustic Roll in the cavity (cavity width 140mm). Linings as in table.</p>	<p>②</p>  <p>Two layers of board fixed to the outside faces of two Gypframe 60 I 70 'I' Stud frameworks with studs at 600mm centres. 100mm Isover Acoustic Roll in the cavity (cavity width 190mm). Linings as in table.</p>	<p>③</p>  <p>Two layers of board fixed to the outside faces of two Gypframe 60 I 50 'I' Stud frameworks with studs at 600mm centres. 100mm Isover Acoustic Roll in the cavity (cavity width 190mm). Linings as in table.</p>	<p>④</p>  <p>Three layers of board fixed to the outside faces of two Gypframe 60 I 70 'I' Stud frameworks with studs at 600mm centres. 100mm Isover Acoustic Roll in the cavity (cavity width 190mm). Linings as in table.</p>
--	---	--	---

Detail	Partition thickness mm	Board type	Lining thickness mm	Max. partition height <sup>1</sup> mm	Sound insulation $R_w (R_w + C_{tr})^2$ dB	Duty rating	Approx. weight kg/m <sup>2</sup>	System reference
<b>90 minutes fire resistance</b> <span style="border: 1px solid black; border-radius: 50%; padding: 2px;">BS</span>								
①	200	Gyproc SoundBloc	2 x 15	2800	66 (58)	Severe	55	A216014
②	250	Gyproc SoundBloc	2 x 15	3900	RD <sup>3</sup>	Severe	55	A216007
③	250	Gyproc SoundBloc	2 x 15	3300	70 (62) / RD <sup>3</sup>	Severe	55	A216013
<b>120 minutes fire resistance</b> <span style="border: 1px solid black; border-radius: 50%; padding: 2px;">BS</span>								
①	200	Gyproc DuraLine	2 x 15	2800	67 (58)	Severe	60	X216011
④	275	Gyproc SoundBloc + Gyproc FireLine	2 x 15 1 x 12.5	3900	RD <sup>3</sup>	Severe	75	A216005

▶ For further assistance in choosing the right solution for your project, try our System Selector; an online tool that enables quick and easy filtering by performance criteria. It provides system specific information downloads including BIM (Revit) objects. Go to [gyproc.ie](http://gyproc.ie)

<sup>1</sup> Based on limiting deflection of L/240 at 200 Pa.

<sup>2</sup> These Gyproc Approved Systems are designed to achieve minimum  $D_{nT,w} + C_{tr}$  45dB, subject to Pre-Completion Testing (Refer to Partitions introduction C04. S01. P109 – table 1)

<sup>3</sup> RD = Robust Detail E-WS-2 (England and Wales) - approved Robust Detail solution designed to achieve minimum  $D_{nT,w} + C_{tr}$  45dB. Minimum 60mm Gypframe 'I' Studs required.

**NB** The fire resistance and sound insulation performances are for imperforate partitions, walls and ceilings incorporating boards with all joints taped and filled, or skimmed according to Gyproc's recommendations. The quoted performances are achieved only if Gyproc and Isover components are used throughout, and the company's fixing recommendations are strictly observed. Any variation in the specification should be checked with Gyproc.



**Table 2 – Solutions to satisfy requirements of ENV 13381-2: 2002 and BS 476: Part 21: 1987<sup>1</sup>**

Board type	Lining thickness mm	Fire resistance min	Section factor <sup>2</sup> A/V (Hp/A) m <sup>-1</sup>
Gyproc SoundBloc	2 x 12.5	30	Up to 300
Gyproc SoundBloc	2 x 15	60	Up to 300
Gyproc SoundBloc	3 x 15	120	Up to 300

<sup>1</sup> Estimated fire protection to structural steelwork within the partition cavity.

<sup>2</sup> Based on four-sided exposure, with no vertical joints aligning with the column, and boards not fixed to the column to maintain air space (10mm for BS or 50mm for EN).

**Table 3 — Maximum heights for Gypframe 'I' Studs at 600mm centres<sup>1</sup>**

Stud type <sup>1</sup>	2 x 12.5mm boards maximum heights	2 x 15mm boards maximum heights
48 I 50	2700	2800
60 I 50	3000	3300
60 I 70	3600	3900
70 I 70	4200 <sup>2</sup>	4300 <sup>2</sup>
92 I 90	5700 <sup>2</sup>	5800 <sup>2</sup>
146 I 80	7200 <sup>2</sup>	7500 <sup>2</sup>

<sup>1</sup> Based on a limiting deflection of L/240 at 200 Pa. Greater heights can be achieved by reducing stud centres for BS 476: Part 22: 1987. Contact the Gyproc Technical Department for further advice.

<sup>2</sup> For heights between 4200mm and 8000mm, Gypframe Deep Flange Floor & Ceiling Channel should be used at base and at head (subject to deflection criteria).



## You may also be interested in...

### GypWall AUDIO

If you require a solution that allows greater maximum heights.

▶ Refer to C04. S09. P245 – GypWall AUDIO.

## Building design

GypWall QUIET IWL comprises a twin frame of Gypframe 'I' Studs at 600mm centres within a twin row of Gypframe Floor & Ceiling Channels.

## Planning — key factors

The position of services and heavy fixtures should be pre-determined and their installation planned into the frame erection stage.

All penetrations will need to be adequately stopped for fire and acoustics.

## Partition to structural steelwork junctions

When designing the layout of rooms requiring separation by sound insulating walls abutting structural steelwork, consideration should be given to the potential loss of sound insulation performance through the steelwork.

▶ Refer to C02. S01. P21 – Building Acoustics.

## Fixing floor and ceiling channels

Gypframe Floor & Ceiling Channels must be securely fixed with a row of fixings at 600mm maximum centres. For 94mm channels and above, two rows of staggered fixings are required, each row at 600mm centres and each fixing 25mm in from the flange. If the floor is uneven, a 38mm thick timber sole plate equal to the width of the channel should be used.

If the concrete or screeded floor is new, consideration should be given to the installation of a damp-proof membrane between the floor surface and the channel or sole plate.

## Splicing

Where the wall heights exceeds the available length of the Gypframe 'I' Stud, sections of stud can be spliced together to the required length using 600mm lengths of the appropriate floor and ceiling channel, fixed with four Gyproc Wafer Head Drywall Screws in each flange to each side.

▶ Refer to Partitions introduction C04. S01. P110 – construction detail 1.

## Partition to suspended ceiling junction

Where a GypWall metal stud partition is fixed to the framework of a **CasoLine MF** ceiling, in accordance with Gyproc's installation instructions, its permissible maximum height is equal to that of where it is fixed direct to a structural soffit of the same height.

In situations where a GypWall metal stud partition passes through a **CasoLine MF** ceiling, which is to both sides of the partition and appropriately fixed to both this partition and perimeter partitions / walls, consideration can be given to the lateral restraint provided by the ceiling when developing the partition specification.

The relevant maximum height is the greater of the floor to **CasoLine MF** ceiling or ceiling to structural soffit height. Care should be taken during installation of tall partitions so as to not adversely affect their performance.

## Door openings

The designer should consider the thickness tolerances of the partition types in relation to the proposed door frame detail. To satisfy *BS 5234: Part 2* requirements for Heavy and Severe Duty Rating partitions, door framing should be specified. The door manufacturer should also be consulted in relation to the door detail.

▶ Refer to Partitions introduction C04. S01. P119 – construction detail 26

## Framing surround for openings

Where services such as horizontal ducts, fire dampers and access panels are required to penetrate the wall, their position should be pre-determined in order that a framed opening can be provided. The openings should be constructed using established metal stud procedures.

▶ Refer to Partitions introduction C04. S01. P121 – construction detail 28-31

## Cavity fire barriers

Where required to maintain fire performance, suitable fire stopping (by others) should be installed full filled within the partition cavity to form a suitable closure.

## Services

### Penetrations

Penetrations of fire-resistant or sound-insulating constructions for services need careful consideration to ensure that the performance of the element is not downgraded. Consideration also needs to be given to the services themselves so they do not act as the mechanism of fire spread or sound transmission.

▶ Refer to C02. S01. P41 – Service installations.

### Electrical

The installation of electrical services should be carried out in accordance with *BS 7671*. The cut-outs in the studs can be used for routing electrical and other small services. Refer to Partitions introduction C04. S01. P110 – construction detail 2. Switch boxes and socket outlets can be supported from Gypframe 99 FC 50 Fixing Channel fixed horizontally between studs, or a high performance socket box detail used where higher acoustic performance is required.

### Independent support

When designing for the installation of services such as fire dampers and associated ductwork through a GypWall partition, consideration should be given to the size and weight of the damper - this will determine whether it can be supported directly from the partition or needs to be independently supported from the structure.

▶ Refer to Partitions introduction C04. S01. P122 – construction details 29-31.

## GypWall QUIET IWL design (continued)

### Deflection heads

Performance details apply to fixed head constructions. Partition head deflection designs may be necessary to accommodate deflections in the supporting floor. Deflection heads may also be required to the underside of roof structures subjected to positive and negative pressures.

For special detailing that minimises the loss of acoustic performance:

- ▶ Refer to C02. S01. P21 – Building acoustics.

For deflection head design:

- ▶ Refer to construction detail 7 within this section.

### Fixtures

Lightweight fixtures can be made directly to the partition linings. Medium weight fixtures can be made to Gypframe 99 FC 50 Fixing Channel. Heavyweight fixtures (to BS 5234) such as wash basins and wall cupboards, can be fixed using plywood secured by Gypframe Service Support Plates.

- ▶ Refer to C02. S01. P41 – Service installations.

### Board finishing

- ▶ Refer to C08. S01. P483 – Finishes.

### Tiling

Tiles can be applied to the surface of lightweight partition systems.

- ▶ Refer to C08. S04. P498 – Tiling

### Robust detail E-WS-2

If using GypWall QUIET IWL as a Robust Detail compliant solution, refer to the Gyproc Technical Department.

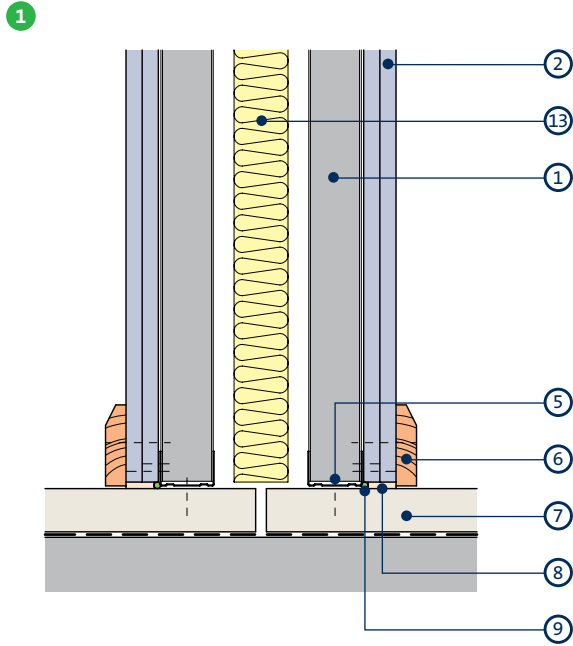


## Important information

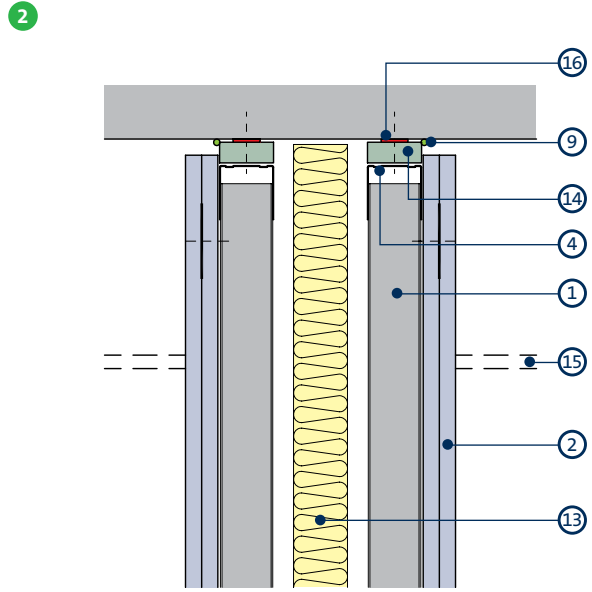
If using GypWall QUIET IWL as Robust Details specification E-WS-2 (England and Wales), note the additional good practice installation guidance provided:

- Keep wall linings at least 190mm apart
- Ensure that the quilt covers the whole wall area without gaps
- Make sure the quilt is compressed by twin frames
- Make sure there is no connection between the two leaves
- Stagger joints in wall linings to avoid air paths
- Seal all joints in outer layer with tape or caulk with sealant
- Follow the manufacturer's instructions

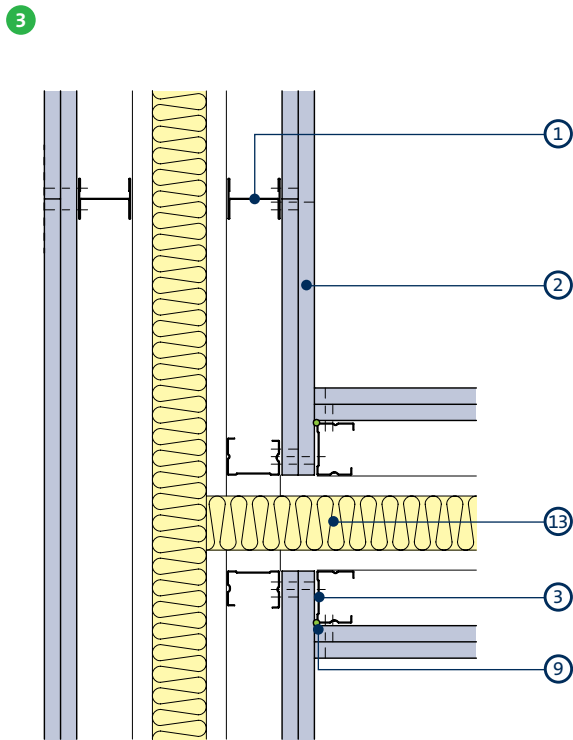
# GypWall QUIET IWL construction details



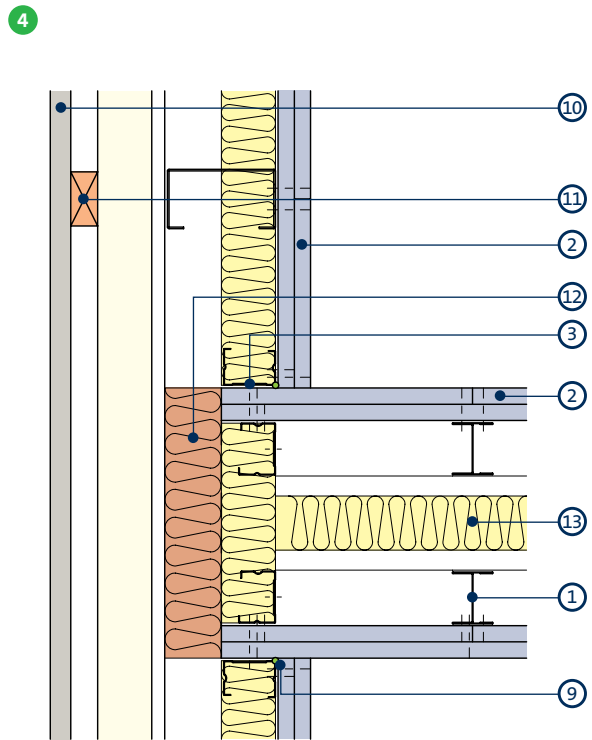
Base on concrete floor with screed



25mm deflection head - up to 60 minutes fire resistance  
- BS 476 Part 22: 1987



'T' junction



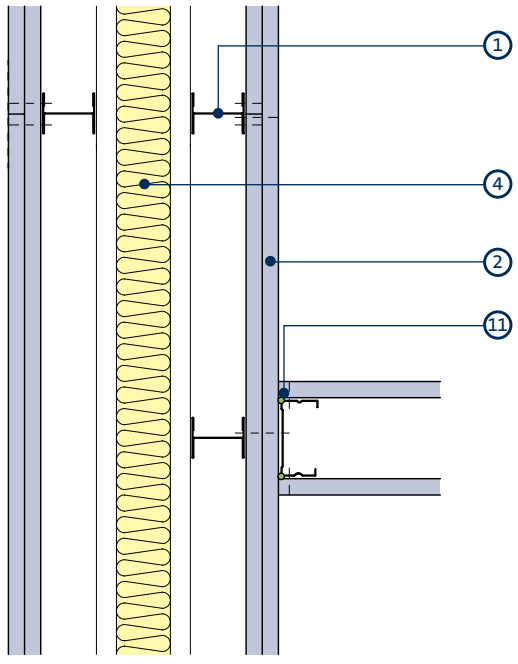
Junction with external wall when acoustic performance is a key consideration - Helps reduce flanking transmission

- 1 Gypframe 'T' Stud
- 2 Gyproc SoundBloc
- 3 Gypframe 'C' Stud
- 4 Gypframe Deep Flange Floor & Ceiling Channel
- 5 Gypframe Folded Edge Standard Floor & Ceiling Channel
- 6 Skirting
- 7 Screed on DPC
- 8 Bulk and fill with Gyproc jointing materials

- 9 Gyproc Sealant
- 10 External Cladding
- 11 External wall stud framework
- 12 Cavity barrier (subject to regulatory requirements)
- 13 Isover Acoustic Roll
- 14 Gyproc CoreBoard or Glasroc F FIRECASE
- 15 Imperforate ceiling
- 16 Gyproc FireStrip

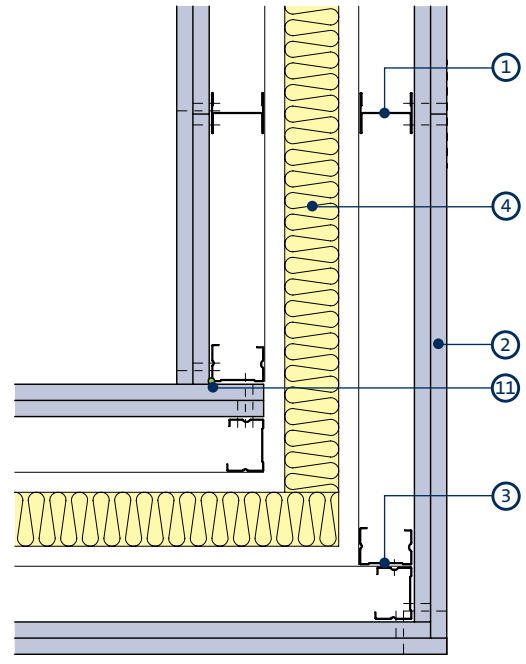
# GypWall QUIET IWL construction details (continued)

5



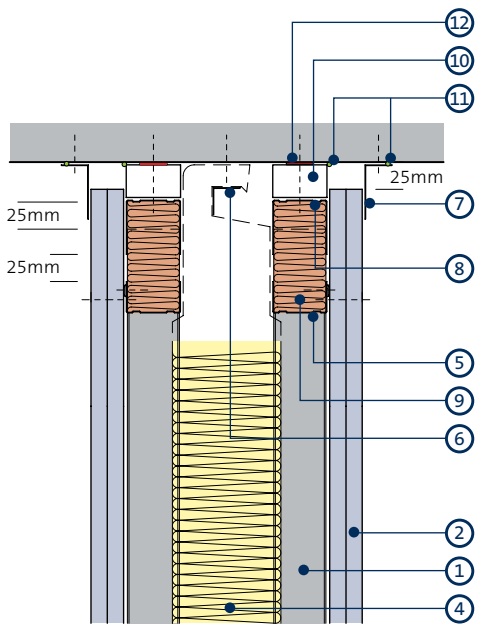
'T' junction with GypWall partition

6



Corner

7

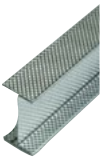


25mm deflection head - 90 or 120 minute fire resistance  
- BS 476 Part 22: 1987

- 1 Gypframe 'T' Stud
- 2 Gyproc SoundBloc
- 3 Gypframe 'C' Stud
- 4 Isover Acoustic Roll
- 5 Gypframe Folded Edge Standard Floor & Ceiling Channel
- 6 Gypframe Steel Angle or timber batten
- 7 Gyframe GA4 Steel Angle
- 8 Gyframe Deep Flange Floor & Ceiling Channel
- 9 Stone mineral wool (by others)
- 10 Glasroc F FIRECASE
- 11 Gyproc Sealant
- 12 Gyproc FireStrip

# GypWall QUIET IWL system components

## Gypframe metal components



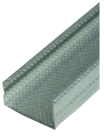
### Gypframe 'I' Studs (48 I 50, 60 I 50, 60 I 70, 70 I 50, 70 I 70, 92 I 90, 146 I 80)

Enhanced strength stud that allows for increased partition height, without increasing partition width. Designed to receive fixing of board to one side only.



### Gypframe 99 FC 50 Fixing Channel

A versatile metal fixing channel used to support medium weight fixtures on walls.



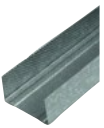
### Gypframe 'C' Studs (48 S 50, 60 S 50, 70 S 50, 70 S 60, 92 S 50, 92 S 60, 92 S 10, 146 S 50)

Vertical stud. Used at abutments and openings.



### Gypframe GFS1 Fixing Strap

Used to support horizontal board joints and within deflection heads.



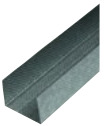
### Gypframe Folded Edge Standard Floor & Ceiling Channels (50 FEC 50, 62 FEC 50, 72 FEC 50, 94 FEC 50, 148 FEC 50)

Standard floor and ceiling channels for retaining the Gypframe studs at floor and ceiling junctions and around openings to heights not exceeding 4200mm.



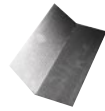
### Gypframe GA5 Internal Fixing Angle

Steel angle providing framing stability and board support.



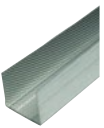
### Gypframe Deep Flange Floor & Ceiling Channels (50 DC 60, 62 DC 60, 72 DC 60, 94 DC 60, 148 DC 60)

Floor and ceiling channels with deep flanges for retaining the Gypframe studs at floor and ceiling junctions for partitions 4200mm to 8000mm high. Also used around openings and in deflection heads (maximum 30mm deflection).



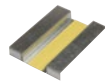
### Gypframe GA6 Splayed Angle

Steel angle providing framing stability and board support.



### Gypframe Extra Deep Flange Floor & Ceiling Channels (50 EDC 70, 72 EDC 80, 94 EDC 70, 148 EDC 80)

Floor and ceiling channels with extra deep flanges for retaining the Gypframe studs at floor and ceiling junctions for partitions over 8000mm high. Also used around openings and in deflection heads (maximum 50mm deflection).



### Gypframe Service Support Plate

For installation of 18mm plywood within a partition cavity to support medium to heavyweight fixtures.

## Board products continued



### Gyproc SoundBloc<sup>1</sup>

Gypsum plasterboard with a high density core for enhanced sound insulation performance.



### Glasroc F FIRECASE

Non-combustible glass-reinforced gypsum board used to form deflection head.



### Gyproc FireLine<sup>1</sup>

Gypsum plasterboard with fire resistant additives.



### Gyproc CoreBoard

Gypsum plasterboard with fire and moisture resistant additives. Used to form deflection head.



### Gyproc DuraLine<sup>1</sup>

Gypsum plasterboard with fire resistant additives and a high density core for enhanced sound insulation and impact resistance performance.

<sup>1</sup> Also available in a Moisture Resistant (MR) version. MR boards are specified in intermittent wet use areas.

## GypWall QUIET IWL system components (continued)

### Fixing products



#### Gyproc Drywall Screws

Corrosion resistant self-tapping steel screws for fixing board-to-timber and board-to-metal framing less than 0.8mm thick. (T studs less than 0.6mm thick).



#### Gyproc Jack-Point Screws

For fixing boards to Gyproframe metal framing 0.8mm thick or greater (T studs 0.6mm thick and greater).



#### Gyproc Collated Drywall Screws

Corrosion resistant self-tapping steel screws for fixing board-to-timber and board-to-metal framing less than 0.8mm thick. (T studs less than 0.6mm thick).



#### Gyproc Wafer Head Jack-Point Screws

Corrosion resistant self-tapping steel screws for fixing metal to metal framing 0.8mm thick and greater (T studs 0.6mm thick and greater).



#### Gyproc Wafer Head Drywall Screws

Corrosion resistant self-tapping steel screws for fixing metal to metal framing 0.8mm thick (T studs less than 0.6mm thick).

### Plasterboard accessories



#### Gyproc Jointing Materials

Jointing compounds, ready mixes and adhesives for reinforcement and finishing of board joints.



#### Gyproc Paper Joint Tape

A paper tape designed for reinforcement of flat joints or internal angles.



#### Gyproc Corner Tape

A paper tape bonded to two corrosion resistant steel strips.



#### Gyproc Sealant

Used to seal air paths for optimum sound insulation.



#### Gyproc FireStrip

A soft extruded linear intumescent gap sealer to maintain fire resistance located directly to the underside of the soffit when forming a deflection head.



#### Gyproc Drywall Primer

Used to prepare for painting. Tub contents 10 litre.



#### Gyproc Control Joint

To accommodate structural movement of up to 7mm.

### Finishing products



#### Gyproc Skimcoat

To provide a plaster skim finish on most common backgrounds including undercoat plasters and plasterboard. Can provide enhanced acoustic performance.



#### Gyproc Carlite Finish

To provide a plaster skim finish on most common backgrounds including undercoat plasters and plasterboard. Can provide enhanced acoustic performance.



#### Gyproc Carlite Ultra Finish

Offers all the benefits of Gyproc Skimcoat and Gyproc Carlite Finish with a reduced set time of 90-120mins, making it ideal for smaller jobs.



#### Gyproc Magnetic Plaster

To provide a plaster skim finish that provides an attraction to magnets used to finish a wide range of backgrounds, including undercoat plasters and plasterboard.

### Finishing products continued

---



#### **Plaster accessories**

Designed for the reinforcement and finishing of board joints before plaster skimming.

---

### Insulation products

---



#### **Isover Acoustic Roll**

Glass mineral wool for enhanced acoustic and thermal performance.

---

# GypWall QUIET IWL installation overview

This is intended to be a basic description of how the system is built.



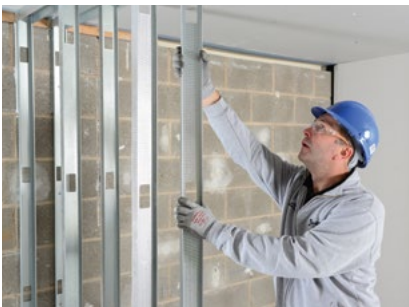
Gypframe Floor & Ceiling Channels are suitably fixed to the floor and soffit in two rows.



Gypframe 'C' Studs are suitably fixed to abutments in two rows.



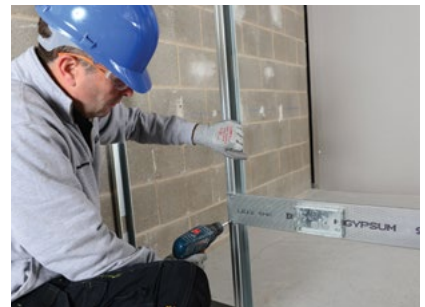
The perimeter of each frame is then sealed with Gyproc Sealant.



Gypframe 'I' Studs are then friction fitted into the Gypframe Channels at the required centres.



Door openings are constructed to the Heavy and Severe Door Duty Rating detail.



M&E services can be located within the partition cavity.



Isover Acoustic Roll is added to the partition cavity.



Gyproc plasterboards are then fixed to the Gypframe framework with Gyproc Drywall Screws and Gyproc Jack-Point Screws.



## Additional information

For full installation details, refer to the **Gyproc Installation Guide**, available to download from [gyproc.ie](http://gyproc.ie)



# GypWall AUDIO

The ultimate sound insulating wall system



## GypWall AUDIO

**GypWall Audio** is a non-loadbearing, twin-frame high performance wall system that provides exceptionally high levels of sound insulation. It is used to separate multi-use facilities, such as lecture theatres, music rooms, multi-screen cinemas, exhibition and conference centres, and leisure centres.

### Key benefits

- Optimal sound insulation performance is achieved through minimal bridging between the Gyproc plasterboard linings and the increased cavity size
- The lightweight system combines high levels of performance and a smaller footprint, compared with masonry alternatives
- Can be specified to create a pristine audio sanctuary; meeting the low frequency requirements of THX cinema certification for auditorium isolation
- Up to 120 minutes fire protection can be provided to structural steel enclosed within the partition cavity of **GypWall Audio**

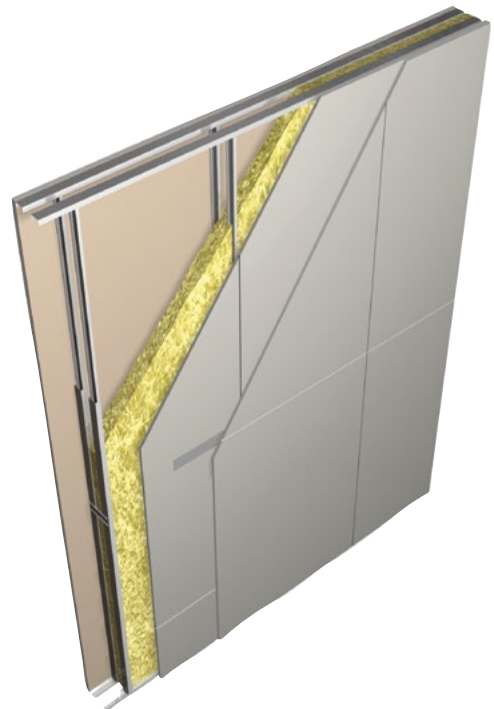
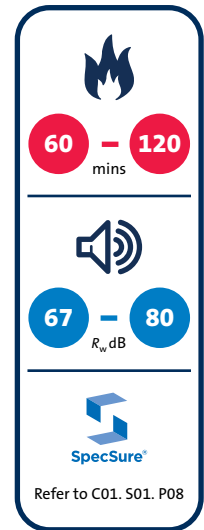
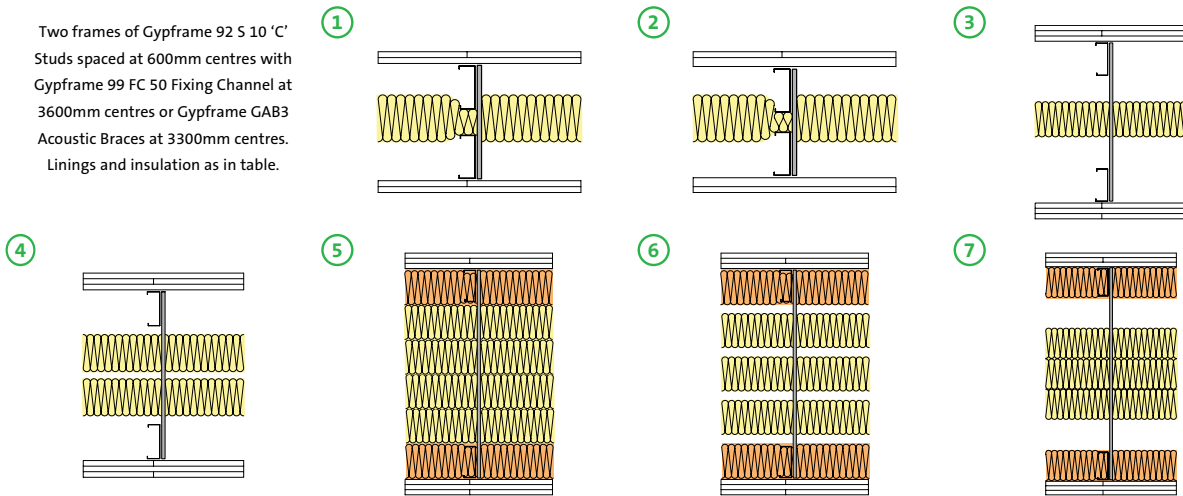




Table 1a – Solutions to satisfy the requirements of BS EN 1364-1: 1999

Two frames of Gypframe 92 S 10 'C' Studs spaced at 600mm centres with Gypframe 99 FC 50 Fixing Channel at 3600mm centres or Gypframe GAB3 Acoustic Braces at 3300mm centres. Linings and insulation as in table.



Detail	Partition thickness mm	Board type	Lining thickness mm	Max. partition height <sup>1</sup> mm		Isover Spacesaver Plus	Sound insulation $R_w + C_{tr}$ dB	Duty rating	Approx. weight kg/m <sup>2</sup>	System reference
				Fixing Channels braces at 3600mm centres	GAB3 Acoustic braces at 3300mm centres					
				L/240 <sup>2</sup> mm	L/240 <sup>2</sup> mm					
<b>60 minutes fire resistance (EN)</b>										
①	300	Gyproc SoundBloc	2 x 12.5	8000	8000	100	67 (56)	Severe	47	A326001
①	300	Gyproc SoundBloc	2 x 15	8000	8000	100	69 (60)	Severe	55	A326002
②	300	Gyproc Plank + Gyproc SoundBloc	1 x 19 + 1 x 12.5	8000	8000	100	70 (60)	Severe	58	A326003
<b>120 minutes fire resistance (EN)</b>										
③	550	Gyproc SoundBloc	3 x 15	9000	9500	100	75 (69)	Severe	80	A326016
④	550	Gyproc SoundBloc	3 x 15	9000	9500	2 x 100	76 (68)	Severe	80	A326013
⑤	600	Gyproc SoundBloc	3 x 15	9000	9500	4 x 100 + 2 x 100 stone mineral wool <sup>3</sup>	77 (69)	Severe	80	A326017
⑥	600	Gyproc SoundBloc	3 x 15	9000	9500	3 x 100 + 2 x 100 stone mineral wool <sup>3</sup>	77 (69)	Severe	80	A326018
⑦	800	Gyproc SoundBloc	3 x 15	9500	9000	3 x 100 + 2 x 100 stone mineral wool <sup>3</sup>	80 (71)	Severe	80	A326019

▶ For further assistance in choosing the right solution for your project, try our System Selector; an online tool that enables quick and easy filtering by performance criteria. It provides system specific information downloads including BIM (Revit) objects. Go to [gyproc.ie](http://gyproc.ie)

<sup>1</sup> For heights between 4200mm and 8000mm, Gypframe Deep Flange Floor & Ceiling Channel should be used at base and at head (subject to deflection criteria). For heights over 8000mm, Gypframe Extra Deep Flange Floor and Ceiling Channel should be used at base and head.

<sup>2</sup> Refer to deflection criteria, in design section.

<sup>3</sup> Minimum density 62kg/m<sup>3</sup>.

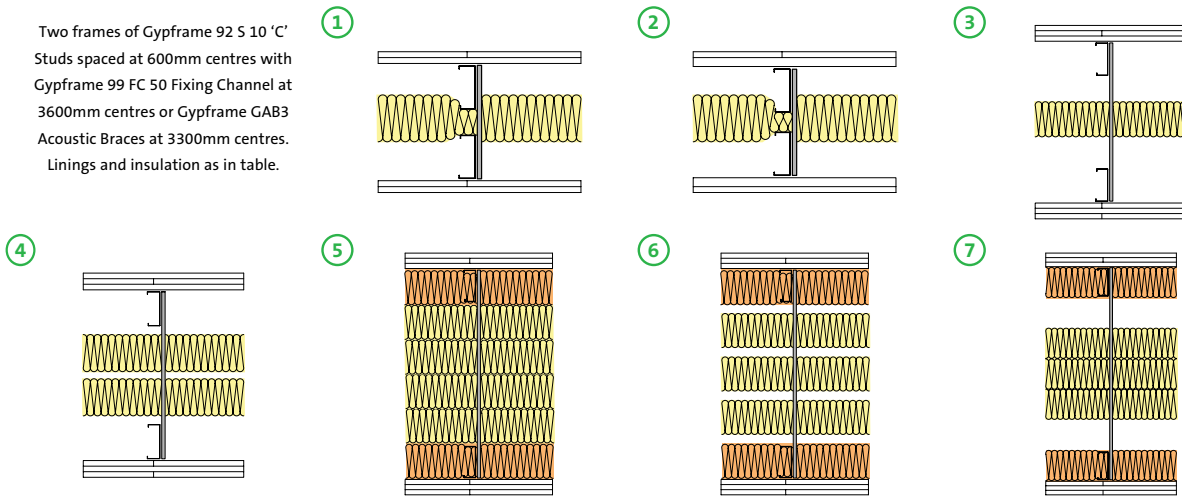
**(NB)** The fire resistance and sound insulation performances are for imperforate partitions, walls and ceilings incorporating boards with all joints taped and filled, or skimmed according to Gyproc's recommendations. The quoted performances are achieved only if Gyproc and Isover components are used throughout, and the Company's fixing recommendations are strictly observed. Any variation in the specifications should be checked with Gyproc.

**(NB)** Each pair of studs must be braced at least once, staggered to the adjacent pairs, irrespective of the partition height or specified bracing centres.



Table 1b – Solutions to satisfy the requirements of BS 476: Part 22: 1987

Two frames of Gypframe 92 S 10 'C' Studs spaced at 600mm centres with Gypframe 99 FC 50 Fixing Channel at 3600mm centres or Gypframe GAB3 Acoustic Braces at 3300mm centres. Linings and insulation as in table.



Detail	Partition thickness mm	Board type	Lining thickness mm	Max. partition height <sup>1</sup> mm				Isover Spacesaver Plus	Sound insulation $R_w + C_{tr}$ dB	Duty rating	Approx. weight kg/m <sup>2</sup>	System reference
				Fixing Channels braces at 3600mm centres		GAB3 Acoustic braces at 3300mm centres						
				L/240 <sup>2</sup> mm	L/125 <sup>2</sup> mm	L/240 <sup>2</sup> mm	L/125 <sup>2</sup> mm					
<b>60 minutes fire resistance (BS)</b>												
①	300	Gyproc SoundBloc	2 x 12.5	8000	9500	8000	10000	100	67 (56)	Severe	47	A326001
<b>90 minutes fire resistance (BS)</b>												
①	300	Gyproc WallBoard	2 x 15	8000	9500	8000	10000	100	67 (58)	Severe	46	A326011
①	300	Gyproc SoundBloc	2 x 15	8000	9500	8000	10000	100	69 (60)	Severe	55	A326002
②	300	Gyproc Plank + Gyproc SoundBloc	1 x 19 + 1 x 12.5	8000	9500	8000	10000	100	70 (60)	Severe	58	A326003
<b>120 minutes fire resistance (BS)</b>												
②	300	Gyproc Plank + Gyproc FireLine	1 x 19 + 1 x 12.5	8000	9500	8000	10000	100	67 (57)	Severe	57	A326006
③	550	Gyproc SoundBloc	3 x 15	9000	11500	9500	11500	100	75 (69)	Severe	80	A326016
④	550	Gyproc SoundBloc	3 x 15	9000	11500	9500	11500	2 x 100	76 (68)	Severe	80	A326013
⑤	600	Gyproc SoundBloc	3 x 15	9000	11500	9500	11500	2 x 100 stone mineral wool <sup>3</sup>	77 (69)	Severe	80	A326017
⑥	600	Gyproc SoundBloc	3 x 15	9000	11500	9500	11500	3 x 100 + 2 x 100 stone mineral wool <sup>3</sup>	77 (69)	Severe	80	A326018
⑦	800	Gyproc SoundBloc	3 x 15	9500	11500	9000	11500	3 x 100 + 2 x 100 stone mineral wool <sup>3</sup>	80 (71)	Severe	80	A326019

► For further assistance in choosing the right solution for your project, try our System Selector; an online tool that enables quick and easy filtering by performance criteria. It provides system specific information downloads including BIM (Revit) objects. Go to [gyproc.ie](http://gyproc.ie)

<sup>1</sup> For heights between 4200mm and 8000mm, Gypframe Deep Flange Floor & Ceiling Channel should be used at base and at head (subject to deflection criteria). For heights over 8000mm, Gypframe Extra Deep Flange Floor and Ceiling Channel should be used at base and head.

<sup>2</sup> Refer to deflection criteria, in design section.

<sup>3</sup> Minimum density 62kg/m<sup>3</sup>.

**(NB)** The fire resistance and sound insulation performances are for imperforate partitions, walls and ceilings incorporating boards with all joints taped and filled, or skimmed according to Gyproc's recommendations. The quoted performances are achieved only if Gyproc and Isover components are used throughout, and the Company's fixing recommendations are strictly observed. Any variation in the specifications should be checked with Gyproc.

**(NB)** Each pair of studs must be braced at least once, staggered to the adjacent pairs, irrespective of the partition height or specified bracing centres.



Table 2 – Solutions to satisfy the requirements of EN 13381-2: 2002 and BS 476: Part 21: 1987<sup>1</sup>

Board type	Lining thickness mm	Fire resistance min	Section factor <sup>2</sup> A/V (Hp/A) m <sup>-1</sup>
Gyproc SoundBloc	2 x 12.5	30	Up to 300
Gyproc SoundBloc	2 x 15	60	Up to 300
Gyproc Plank + Gyproc SoundBloc	1 x 19 + 1 x 12.5	60	Up to 300
Gyproc Plank + Gyproc FireLine	1 x 19 + 1 x 12.5	60	Up to 300
Gyproc SoundBloc	3 x 15	120	Up to 300

<sup>1</sup> Estimated fire protection to structural steelwork within the partition cavity.

<sup>2</sup> Based on four-sided exposure, with no vertical joints aligning with the column, and boards not fixed to the column to maintain air space (10mm for BS or 50mm for EN).

Table 3 – Acoustic performance of GypWall audio at low frequencies

Detail	Overall wall thickness mm	Board type	Lining thickness mm	Isover Spacesaver Plus	Octave band sound reduction index (R) dB			R <sub>w</sub> dB	System reference
					63Hz	125Hz	250Hz		
①	300	Gyproc SoundBloc	2 x 12.5	100	29.4	41.8	55.6	67	A326001
①	300	Gyproc WallBoard	2 x 15	100	30.4	43.4	55.3	67	A326011
②	300	Gyproc Plank + Gyproc FireLine	1 x 19 + 1 x 12.5	100	29.7	43.1	55.3	67	A326006
①	300	Gyproc SoundBloc	2 x 15	100	35.6	45.8	57.5	69	A326002
②	300	Gyproc Plank + Gyproc SoundBloc	1 x 19 + 1 x 12.5	100	34.8	46.1	58.6	70	A326003
③	550	Gyproc SoundBloc	3 x 15	100	37.9	56.7	63.0	75	A326016
④	550	Gyproc SoundBloc	3 x 15	2 x 100	41.1	55.7	62.0	76	A326013
⑤	600	Gyproc SoundBloc	3 x 15	4 x 100 + 2 x 100 stone mineral wool <sup>1</sup>	46.0	55.0	65.0	77	A326017
⑥	600	Gyproc SoundBloc	3 x 15	3 x 100 + 2 x 100 stone mineral wool <sup>1</sup>	46.5	55.7	63.8	77	A326018
⑦	800	Gyproc SoundBloc	3 x 15	3 x 100 + 2 x 100 stone mineral wool <sup>1</sup>	51.3	57.5	67.1	80	A326019

► For further assistance in choosing the right solution for your project, try our System Selector; an online tool that enables quick and easy filtering by performance criteria. It provides system specific information downloads including BIM (Revit) objects. Go to [gyproc.ie](http://gyproc.ie)

<sup>1</sup> Minimum density 62kg/m<sup>3</sup>.

# GypWall Audio design

## Building design

GypWall Audio comprises braced twin rows of Gypframe 92 S 10 'C' Studs installed at 600mm centres within Gypframe Floor & Ceiling Channels.

## Planning – key factors

The position of services and heavy fixtures should be pre-determined and their installation planned into the frame erection stage.

Designers and site management should give full consideration to the potential exposure of GypWall Audio to differential pressures, such as wind loadings during installation.

## Fixing floor and ceiling channels

Gypframe Floor & Ceiling Channels must be securely fixed with two rows of staggered fixings, each row at 600mm centres and each fixing 25mm in from the flange. If the floor is uneven, a 38mm thick timber sole plate equal to the width of the channel should be used. If the concrete or screeded floor is new, consideration should be given to the installation of a damp-proof membrane between the floor surface and the channel or sole plate.

## Splicing

To extend studs, overlap by 600mm (minimum). Fix together using Gyproc Wafer Head Drywall Screws or steel pop rivets (two to each flange).

► Refer to Partitions introduction C04. S01. P110 – construction detail 1.

## Partition to structural steelwork junctions

When designing the layout of rooms requiring separation by sound insulating walls abutting structural steelwork, consideration should be given to the potential loss of sound insulation performance through the steelwork.

► Refer to C02. S01. P21 – Building acoustics.

## Door openings

Any openings will require careful detailing if the acoustic performance is to be maintained. Specialist heavy acoustic doorsets may require additional support.

## Framing surround for openings

Where services such as horizontal ducts, fire dampers and access panels are required to penetrate the wall, their position should be pre-determined in order that a framed opening can be provided.

► Refer to C04. S01. P121 – Service installations.

## Cavity fire barriers

Where required to maintain fire performance, suitable fire stopping (by others) should be installed full filled within the partition cavity to form a suitable closure.

## Control joints

Control joints may be required in the partition to relieve stresses induced by expansion and contraction of the structure (refer to Partitions introduction C04. S01. P115 – construction detail 12). They should coincide with movement joints within the surrounding structure.

## Deflection heads

Partition head deflection designs may be necessary to accommodate deflections in the supporting floor. Deflection heads may also be required to the underside of roof structures subjected to positive and negative pressures.

► Refer to construction details 4 and 5 within this section.

## Deflection criteria

Our normal recommendation is to build to a deflection criteria L/240 at 200 Pa, however it is common for this system to be built to L/125 at 200 Pa (*BS 476: Part 22: 1987* fire resistance only).

Partitions built to a maximum height based on L/125 at 200 Pa will exhibit greater deflection compared to partitions built to a maximum height based on L/240 at 200 Pa. Partitions with deflection characteristics outside the standard L/240 criteria will exhibit more flex during installation and in general use, and therefore we recommend you verify the acceptability of the deflections with the relevant interested parties before specifying / installing partitions based on L/125 criteria.

## Cross bracing

Laboratory tests were carried out on walls without bracing. The results, however, are a realistic representation of site conditions in which Gypframe 99 FC 50 Fixing Channel cross-braces are fitted at the recommended 3600mm maximum centres, provided that appropriate measures are taken on site to eliminate flanking sound transmission. All braces must be staggered by half distance of the brace centres. Test evidence is provided by our Report ATR 1299, where a site test on a large multi-screen cinema wall achieved comparable performance to the equivalent specification tested in the laboratory without bracing.

Acoustic designers may prefer the option of a resilient acoustic brace. The Gypframe GAB3 Acoustic Brace has been shown in tests not to downgrade acoustic performance in laboratory conditions. However, as a result of the mechanics of this brace fixing centres should be reduced from 3600mm to 3300mm, staggered by half distance of brace centres. Maximum recommended wall heights will vary.

► Refer to tables 1a and 1b within this section.

The minimum and maximum wall widths for which Gypframe GAB3 Acoustic Brace can be used without modification are 300mm and 600mm respectively. Likewise, the minimum and maximum cavity width between the two stud frames for which Gypframe GAB3 Acoustic Brace can be used without modification are 100mm

and 400mm respectively.

The Gypframe GAB3 Acoustic Brace may be cut using a hacksaw or power tool. If required, the Gypframe GAB Acoustic Brace can be extended by fixing a short length of Gypframe 92 S 10 'C' Stud to one brace with four Gyproc Wafer Head Jack-Point Screws (ensure a 75mm minimum overlap to each stud with no contact to board lining). The short length of stud should also be fixed to the vertical studs with four Gyproc Wafer Head Jack-Point Screws.

Care should be taken to ensure Gypframe GAB3 Acoustic Braces are correctly and fully engaged and not mis-aligned. Where partition heights are specified based on lateral restraint from a suitable ceiling, either this ceiling should be in place at the time of installation or temporary restraint should be used.

Each pair of studs must be braced at least once, staggered to the adjacent pairs, irrespective of the partition height or specified bracing centres.

### Board fixing

In common with building practice, the twin frame wall should be boarded progressively from each side of the partition. This will help prevent differential loadings on the framework.

### Services

#### Penetrations

Penetrations of fire-resistant or sound-insulating constructions for services need careful consideration to ensure that the performance of the element is not downgraded. Consideration also needs to be given to the services themselves so they do not act as the mechanism of fire spread or sound transmission.

▶ Refer to C02. S01. P41 – Service installations.

#### Electrical

The installation of electrical services should be carried out in accordance with BS 7671. The cut-outs in the studs can be used for routing electrical and other small services (refer to Partitions introduction C04. S01. P110 – construction detail 2). Switch boxes and socket outlets can be supported from Gypframe 99 FC 50 Fixing Channel fixed horizontally between studs, or a high performance socket box detail used where higher acoustic performance is required.

#### Independent support

When designing for the installation of services such as fire dampers and associated ductwork through a GypWall partition, consideration should be given to the size and weight of the damper - this will determine whether it can be supported directly from the partition or needs to be independently supported from the structure.

▶ Refer to Partitions introduction C04. S01. P122 – construction details 29-31.

### Fixtures

Lightweight fixtures can be made directly to the partition linings. Medium weight fixtures can be made to Gypframe 99 FC 50 Fixing Channel. Heavyweight fixtures (to BS 5234) such as wash basins and wall cupboards, can be fixed using plywood secured by Gypframe Service Support Plates.

▶ Refer to C02. S01. P41 – Service installations.

### Access for maintenance

Gyproc Profiflex Access Panels are available to provide access for maintenance. Access panels must be fully compatible with drywall construction and match the fire rating of the partition.

▶ Refer to the Gyproc Technical Department for further information.

### Board finishing

▶ Refer to C08. S01. P483 – Finishes

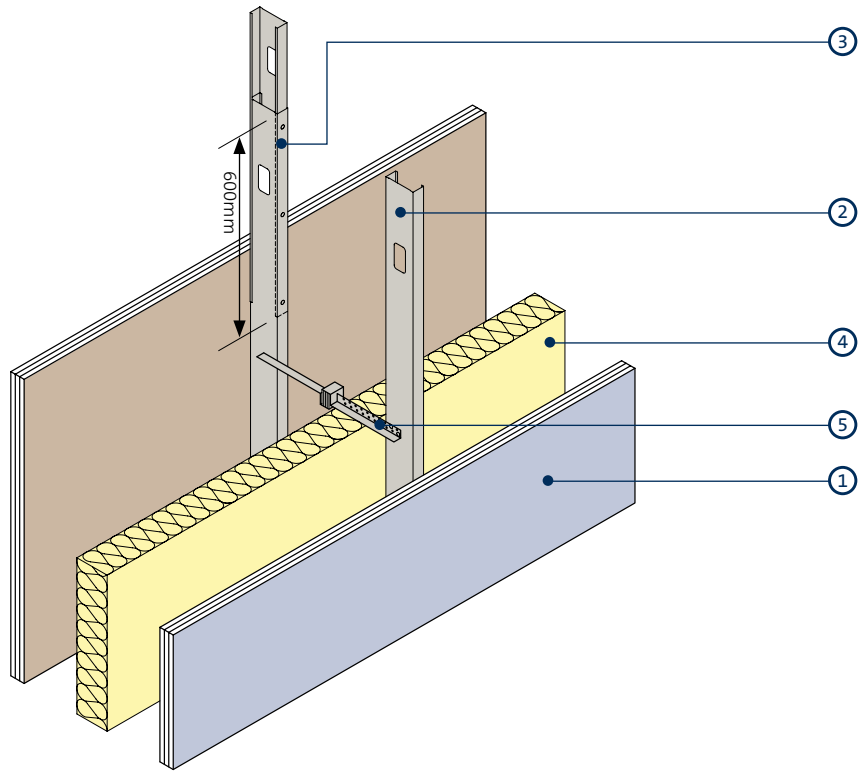
### Tiling

Tiles can be applied to the surface of lightweight partition systems.

▶ Refer to C08. S04. P498 – Tiling

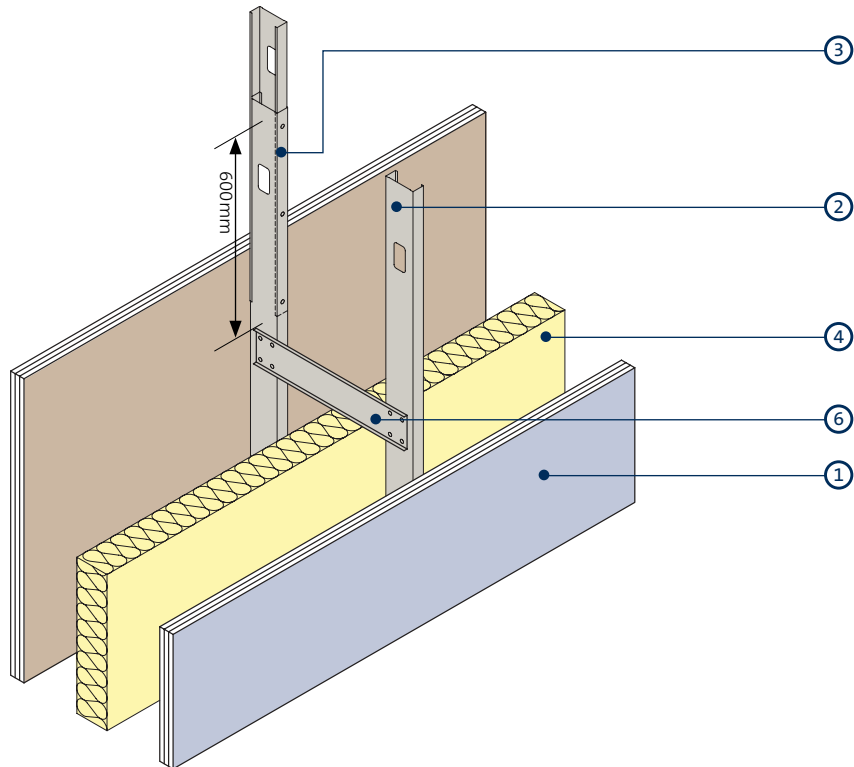
# GypWall audio construction details

1



Splicing and acoustic bracing

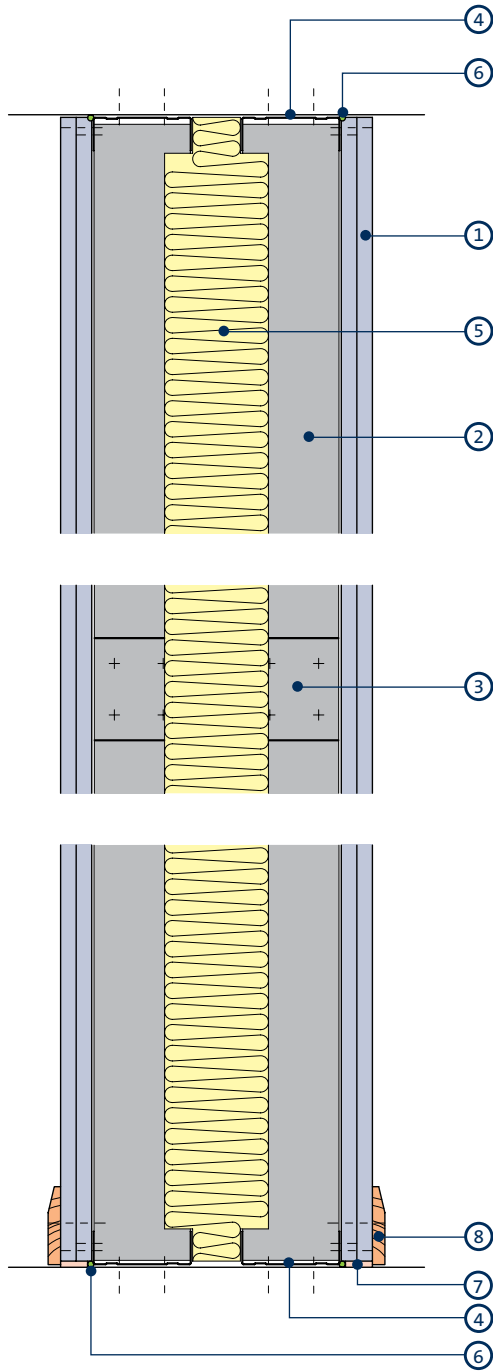
2



Splicing and solid bracing

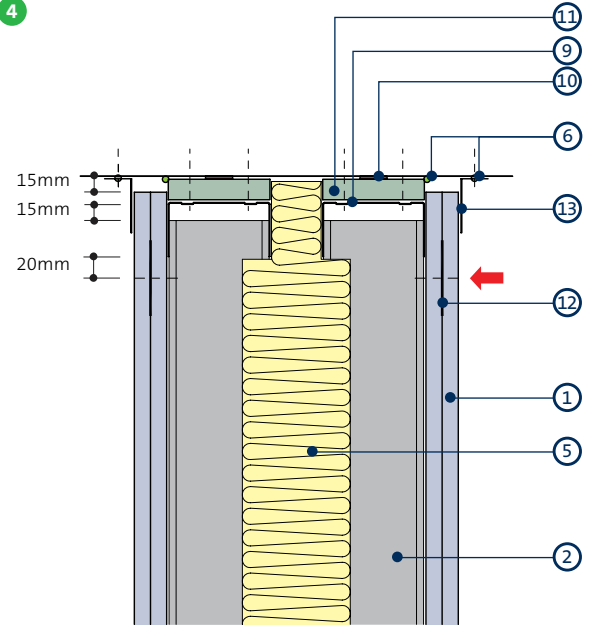
- |  |  |
|--|--|
| 1 Gyproc plasterboard  | 4 Isover Spacesaver Plus   |
| 2 Gypframe 92 S 10 'C' Stud  | 5 Gypframe GAB3 Acoustic Brace                                   |
| 3 Splice - 600mm overlap with three Gyproc Wafer Head Jack-Point Screws into each flange | 6 Brace formed from Gypframe 99 FC 50 Fixing Channel (staggered) |

3



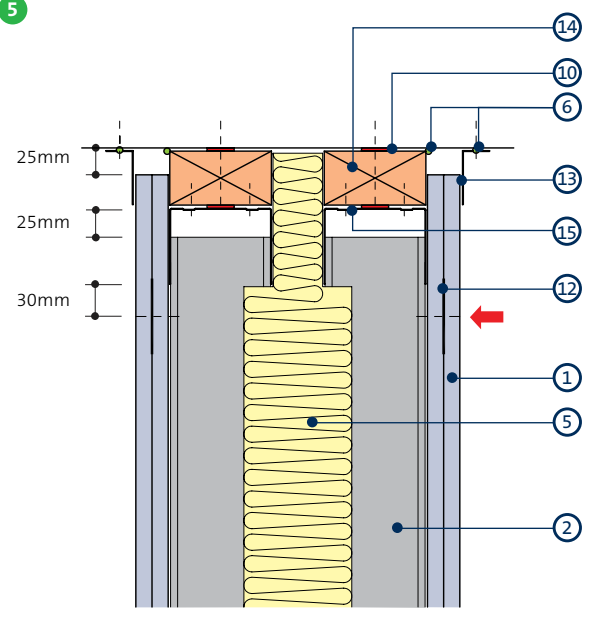
Head and base

4



Deflection head for 15mm downward movement and 60 minutes fire resistance - BS 476 Part 22: 1987

5



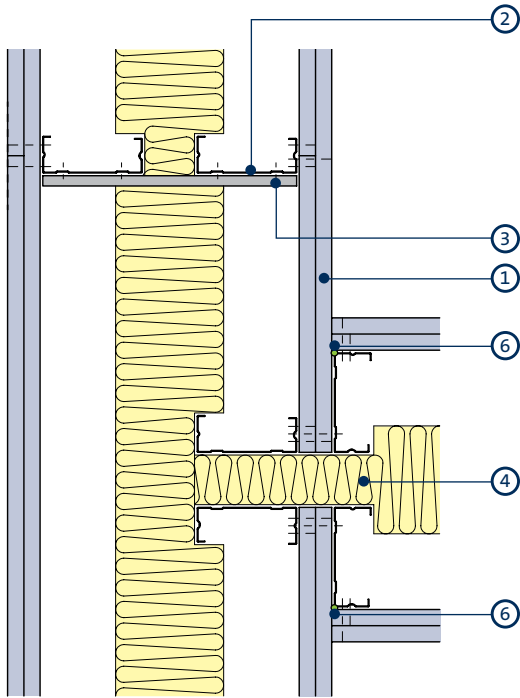
Deflection head for ±25mm movement and 60 minutes fire resistance - BS 476 Part 22: 1987

- 1 Gyproc plasterboard
- 2 Gypframe 92 S 10 'C' Stud
- 3 Gypframe 99 FC 50 Fixing Channel
- 4 Gypframe Floor & Ceiling Channel
- 5 Isover Spacesaver Plus
- 6 Gyproc Sealant
- 7 Bulk fill with Gyproc jointing materials (where gap exceeds 5mm)
- 8 Skirting

- 9 Gypframe Deep Flange Floor & Ceiling Channel suitably fixed through fire-stop to structure
- 10 Gyproc FireStrip
- 11 Gyproc CoreBoard or Glasroc F FIRECASE
- 12 Gypframe GFS1 Fixing Strap
- 13 Gypframe GA4 Steel Angle
- 14 Timber head plate suitably fixed to structure
- 15 Gypframe Extra Deep Flange Floor & Ceiling Channel suitably fixed to timber head plate

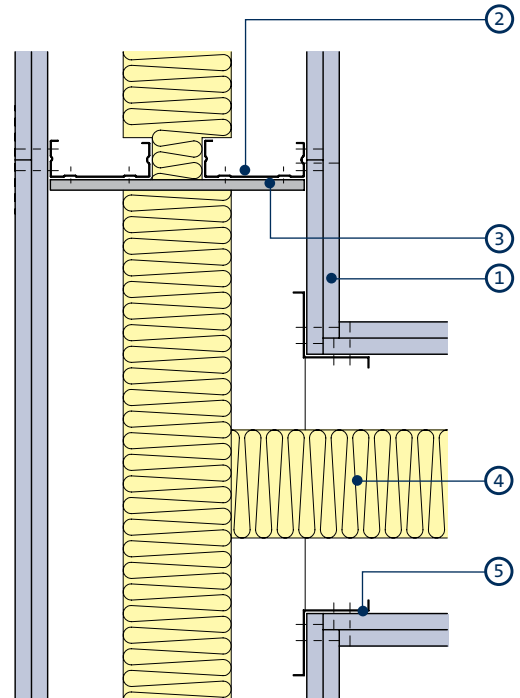
**NB** No fixings should be made through the boards into the flanges of the head channel. The arrow (→) denotes the position of the uppermost board fixing, which should be made into Gypframe GFS1 Fixing Strap. Continuous Gyproc FireStrip must be installed as shown to maintain fire performance.

6



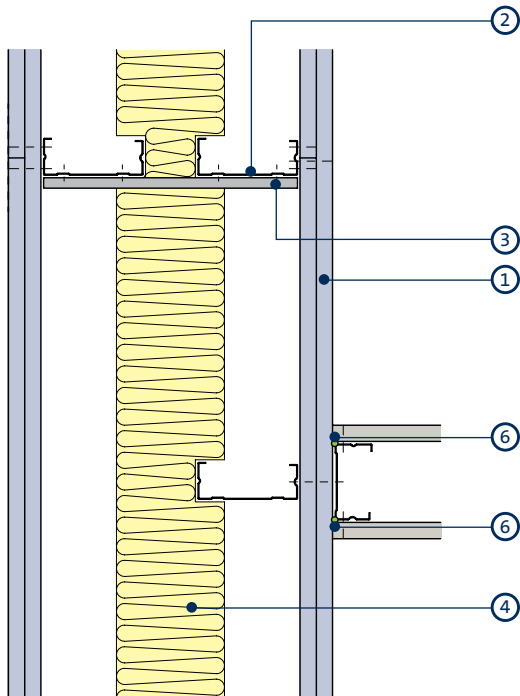
'T' junction

7



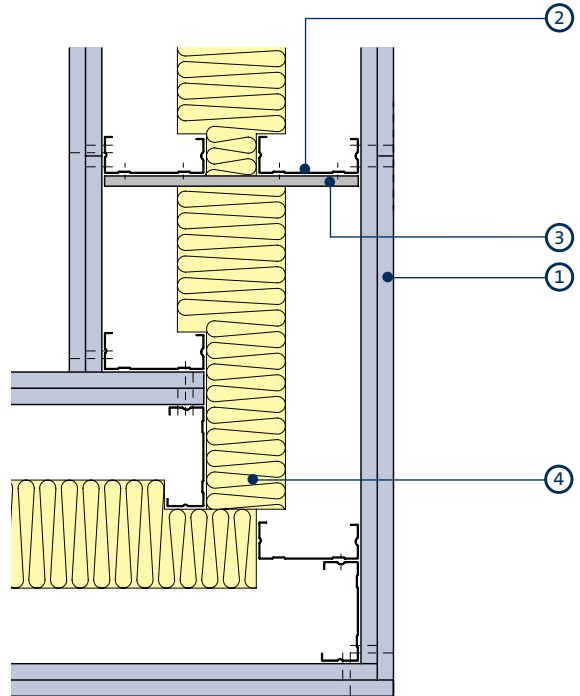
Alternative 'T' junction using GA5 Internal Fixing Angle

8



'T' junction with a low acoustic performance  
GypWall partition

9



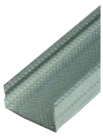
Internal / external corner

- 1 Gyproc plasterboard
- 2 Gypframe 92 S 10 'C' Stud
- 3 Gypframe 99 FC 50 Fixing Channel

- 4 Isover Spacesaver Plus
- 5 Gypframe GA5 Internal Fixing Angle
- 6 Gyproc Sealant

# GypWall audio system components

## Gypframe metal components



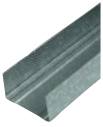
### Gypframe 'C' Studs 92 S 10

Vertical stud providing acoustic and structural performances designed to receive fixing of board.



### Gypframe GAB3 Acoustic Brace

To cross-brace two rows of Gypframe studs for optimum acoustic performance.



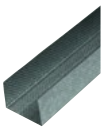
### Gypframe Folded Edge Standard Floor & Ceiling Channels 94 FEC 50

Standard floor and ceiling channels for retaining the Gypframe studs at floor and ceiling junctions and around openings to heights not exceeding 4200mm.



### Gypframe GF51 Fixing Strap

Used to support horizontal board joints and within deflection heads.



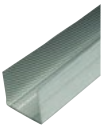
### Gypframe Deep Flange Floor & Ceiling Channels 94 DC 60

Floor and ceiling channels with deep flanges for retaining the Gypframe studs at floor and ceiling junctions for partitions 4200mm to 8000mm high. Also used around openings and in deflection heads (maximum 30mm deflection).



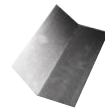
### Gypframe GA5 Internal Fixing Angle

Steel angle providing framing stability and board support.



### Gypframe Extra Deep Flange Floor & Ceiling Channels 94 EDC 70

Floor and ceiling channels with extra deep flanges for retaining the Gypframe studs at floor and ceiling junctions for partitions over 8000mm high. Also used around openings and in deflection heads (maximum 50mm deflection).



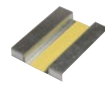
### Gypframe GA6 Splayed Angle

Steel angle providing framing stability and board support.



### Gypframe 99 FC 50 Fixing Channel

A versatile metal fixing channel used to support medium weight fixtures on walls. Also used to cross-brace the two rows of Gypframe studs.



### Gypframe Service Support Plate

For installation of 18mm plywood within a partition cavity to support medium to heavyweight fixtures.

## Board products



### Gyproc SoundBloc<sup>1</sup>

Gypsum plasterboard with a high density core for enhanced sound insulation performance.



### Gyproc WallBoard

Standard gypsum plasterboard.



### Gyproc Plank

Standard gypsum plasterboard located as an inner layer.



### Gyproc DuraLine<sup>1</sup>

Gypsum plasterboard with fire resistant additives and a high density core for enhanced sound insulation and impact resistance performance. Used as a substitute outer board layer.



### Gyproc FireLine<sup>1</sup>

Gypsum plasterboard with fire resistant additives.



### Glasroc F FIRECASE

Non-combustible glass-reinforced gypsum board used to form deflection head.

<sup>1</sup> Also available in a Moisture Resistant (MR) version. MR boards are specified in intermittent wet use areas.

## Board products



### Gyproc CoreBoard

Gypsum plasterboard with fire and moisture resistant additives used to form deflection head.

## Fixing products



### Gyproc Jack-Point Screws

Corrosion resistant self-tapping steel screws for fixing board to metal framing 0.8mm thick and greater ('I' studs 0.6mm thick and greater).



### Gyproc Wafer Head Jack-Point Screws

Corrosion resistant self-tapping steel screws for fixing metal to metal framing 0.8mm thick and greater.

## Plasterboard accessories



### Gyproc Jointing Materials

Jointing compounds, ready mixes and adhesives for reinforcement and finishing of board joints.



### Gyproc Control Joint

To accommodate structural movement of up to 7mm.



### Gyproc FireStrip

A soft extruded linear intumescent gap sealer to maintain fire resistance located directly to the underside of the soffit when forming a deflection head.



### Gyproc edge and angle beads

Protecting and enhancing board edges and corners.



### Gyproc Sealant

Used to seal air paths for optimum sound insulation.



### Gyproc Paper Joint Tape

A paper tape designed for reinforcement of flat joints or internal angles.



### Gyproc Drywall Primer

Used to prepare for painting. Tub contents 10 litre.

## Finishing products



### Gyproc Skimcoat

To provide a plaster skim finish on most common backgrounds including undercoat plasters and plasterboard. Can provide enhanced acoustic performance.



### Gyproc Carlite Finish

To provide a plaster skim finish on most common backgrounds including undercoat plasters and plasterboard. Can provide enhanced acoustic performance.



### Gyproc Carlite Ultra Finish

Offers all the benefits of Gyproc Skimcoat and Gyproc Carlite Finish with a reduced set time of 90-120mins, making it ideal for smaller jobs.



### Plaster accessories

Designed for the reinforcement and finishing of board joints before plaster skimming.

## GypWall audio system components (continued)

### Insulation products

---



#### **Isover Spacesaver Plus**

Glass mineral wool roll for acoustic performance.

#### **Stone mineral wool** (62kg/m<sup>3</sup> by others)

For enhanced acoustic performance at low frequency.

---

# GypWall audio system installation overview

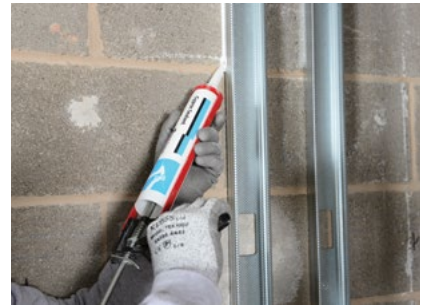
This is intended to be a basic description of how the system is built.



Gypframe Floor & Ceiling Channels are suitably fixed to the floor and soffit in two rows.



Gypframe 92 S 10 'C' Studs are fixed at abutments and door openings in two rows.



Gyproc Sealant is applied to the frame perimeters to seal airpaths.



Gypframe 92 S 10 'C' Studs are then friction fitted into the Gypframe Channels at the required centres, and door openings are constructed to the Heavy and Severe Duty Rating door detail.



The Gypframe 92 S 10 'C' Studs are then braced together in pairs with either staggered Gypframe GAB3 Acoustic Braces,



or staggered Gypframe 99 FC 50 Fixing Channels.



M&E services can be located within the partition cavity.



Insulation is added to the partition cavity.



Gyproc plasterboards are then fixed to the Gypframe framework with Gyproc Jack-Point Screws.



When applying multiple layers of board, ensure that all board joints are staggered on both sides of the partition.



## Additional information

For full installation details, refer to the [Gyproc Installation Guide](#), available to download from [gyproc.ie](#)

# GypWall SUPERIOR

The extra strong, extra durable, sound resistant system that you can direct fix to

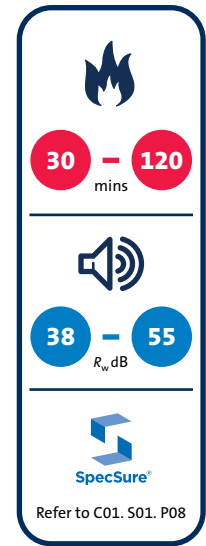


# GypWall SUPERIOR

Utilising the latest addition to the Gyproc performance board range, Gyproc Habito, GypWall SUPERIOR is our extra strong, extra durable, sound resistant system that you can direct fix to. Gyproc Habito provides enhanced acoustics, impact resistance and for the first time, fixing capability.

## Key benefits

- A high impact-resistant partition system for use where a more durable structure is required
- The sound insulation of GypWall SUPERIOR partitions can be increased with the inclusion of Isover Acoustic Roll
- Hang up to 15kg from one 5mm woodscrew
- Can achieve up to 120 minutes fire resistance



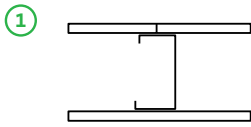
# GypWall SUPERIOR Performance

## 70mm Gypframe “C” Studs

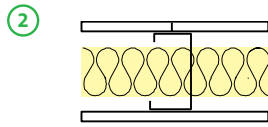
For details of when to specify fire resistance using BS  
 ▶ Refer to C02. S01. P18



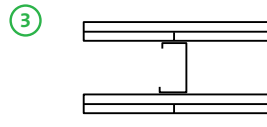
Table 1a – Solutions to satisfy requirements of BS 5234



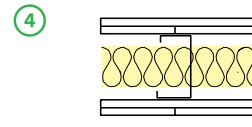
One layer of board each side of 70mm Gypframe 'C' studs at 600mm centres



One layer of board each side of 70mm Gypframe 'C' studs at 600mm centres plus 50mm Isover Acoustic Roll in the cavity



Two layers of board each side of 70mm Gypframe 'C' studs at 600mm centres



Two layers of board each side of 70mm Gypframe 'C' studs at 600mm centres plus 50mm Isover Acoustic Roll in the cavity

Detail	Partition thickness mm	Inner board type mm	Outer board type mm	Max Partition height <sup>1</sup> mm	Sound insulation $R_w$ dB	Duty rating	Approx. weight kg/m <sup>2</sup>	System Reference
<b>30 minutes fire resistance</b> (BS) <sup>2</sup>								
1	97	Habito 12.5mm		3600	38	Severe	26	K206001
2	97	Habito 12.5mm		3600	44	Severe	27	K206002
<b>60 minutes fire resistance</b> (BS) <sup>2</sup>								
3	122	SoundBloc 12.5mm	Habito 12.5mm	4600	49	Severe	48	K206003
4	122	SoundBloc 12.5mm	Habito 12.5mm	4600	55	Severe	49	K206005
<b>120 minutes fire resistance</b> (BS) <sup>2</sup>								
3	122	Habito 12.5mm	Habito 12.5mm	4600	48	Severe	50	K206004
4	122	FireLine 12.5mm	Habito 12.5mm	4600	52	Severe	49	K206006
4	122	Habito 12.5mm	Habito 12.5mm	4600	53	Severe	51	K206007

<sup>1</sup>Based on a limiting deflection of L/240 at 200Pa with studs at 600m centres. If greater heights are required, please refer to the design section. For heights between 4200mm and 8000mm, Gypframe Deep Flange Door and Ceiling Channels (DC) should be used at the head and base. Where special design requirements, please consult the Gyproc Technical Department for guidance.

<sup>2</sup> Board joints must be reinforced with Gyproc Paper Joint Tape for the quoted fire resistance periods to be achieved.

## Building design

Whilst our GypWall partition systems are non-loadbearing, they are able to provide resistance to levels of horizontal uniformly distributed loads in accordance with BS 6399.

► Refer to C02. S01. P37 – Robustness.

## Planning – key factors

The position of some services and heavy fixtures should be predetermined, and their installation planned into the frame erection stage. All penetrations will need to be adequately fire-stopped if integrity is to be maintained.

## Fixing floor and ceiling channels

Floor and ceiling channels must be securely fixed with a row of fixings at 600mm maximum centres (148mm channels require two rows of staggered fittings at 600mm centres in each row). If the floor is uneven, a 38mm thick timber sole plate equal to the width of the channel should be used.

If the concrete or screeded floor is new, consideration should be given to the installation of a damp proof membrane between the floor surface and the channel or sole plate.

## Door openings

The designer should consider the thickness tolerances of the partition types in relation to the proposed door frame detail. To satisfy BS5234 requirements for heavy and severe duty, door framing should be specified in accordance with Figure 5 or 6 (on the following pages).

Exceptionally heavy doorsets may require additional provision. Contact the Gyproc Technical Department if further guidance is required.

## Cavity Fire Barriers

Minimum 12.5mm Gyproc plasterboard, screw-fixed into the web of perimeter channels or vertical studs, will provide a satisfactory closure to flame or smoke.

► Refer to C06. S06. P422 – Cavity fire barriers.

## Control Joints

Control joints may be required in the partition to relieve stresses induced by expansion and contraction of the structure. The location of control joints is at the discretion of the specifier. It is recommended that they coincide with movement joints within the surrounding structure.

## Deflection heads

Deflection heads, by definition, must be able to move and, therefore, achieving an airtight seal is difficult. Inevitably, this will have a detrimental effect on the acoustic performance of any wall which incorporates deflection at the head. The approach shown in C04. S06. P207 – GypWall STAGGERED, could be considered to minimise loss of performance. In most cases, a suspended ceiling will also assist in minimising loss of performance.

## Services

### Penetrations

Penetrations of fire resistant constructions for services need careful consideration to ensure that the integrity of the element is not impaired, and also that the services themselves do not act as a mechanism of fire spread.

It is important to use only those services and their installations which have been shown by fire test to be able to maintain the integrity of the construction.

### Electrical

The installation of electrical services should be carried out in accordance with all relevant legislation, regulations and guidance. The cut-outs in the studs can be used for routing electrical and other small services.

### Fixtures

Due to the inherent strength of Gyproc Habito, some fixtures can be applied directly to the board.

► Refer to C02. S01. P44 - Table 13

### Jointing

When installing Gyproc Habito onto a metal frame, tape and joint preparation is recommended and approved by Gyproc. The Gyproc Jointing process can provide a durable joint reinforcement with a smooth, continuous, crack free surface.

► Refer to C08. S03. P492 – Jointing

### Tiling

Tiles up to 32kg/m<sup>2</sup> can be applied to the surface of lightweight partition systems.

► Refer to C08. S04. P498 – Tiling.

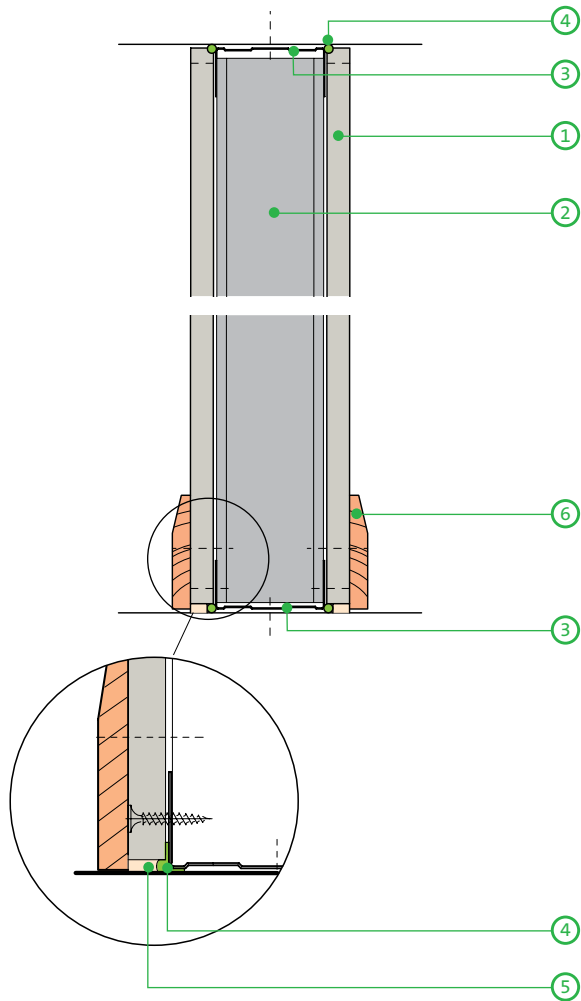
### Construction details

For standard GypWall construction details

► Refer to Partitions introduction C04. S01. P110 – construction details.

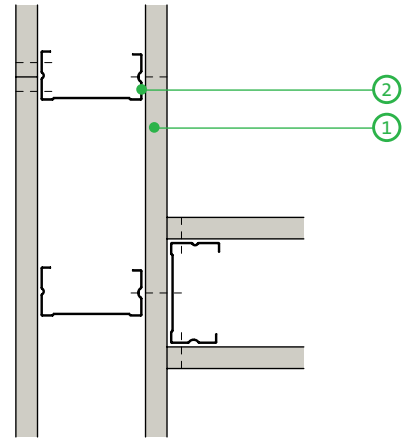
# GypWall SUPERIOR construction details

1



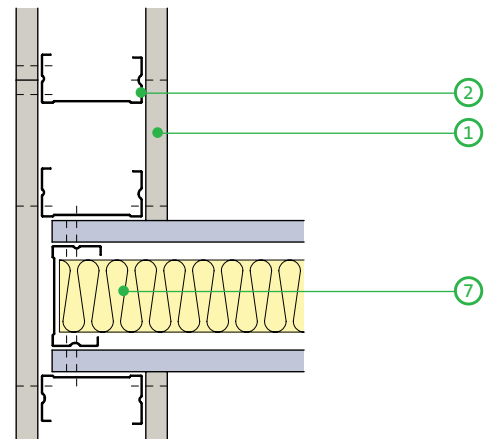
Head and base

2



'T' junction - single layer

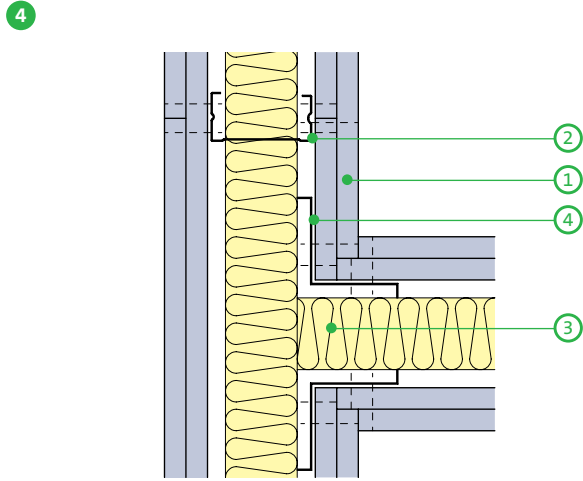
3



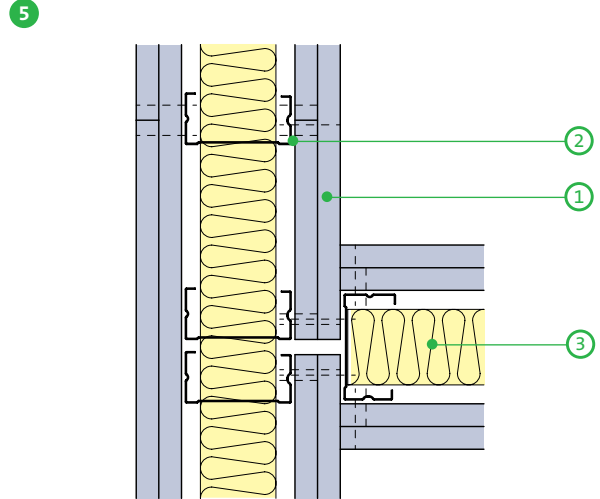
'T' Junction when partition with higher acoustic performance abuts a partition with lower acoustic performance. Acoustic principles only - detail may not be suitable for all solutions

- 1 Gyproc plasterboard
- 2 Gypframe 'C' Stud
- 3 Gypframe Floor & Ceiling Channel
- 4 Gyproc Sealant
- 5 Bulk fill Gyproc jointing materials (where gap exceeds 5mm)
- 6 Skirting

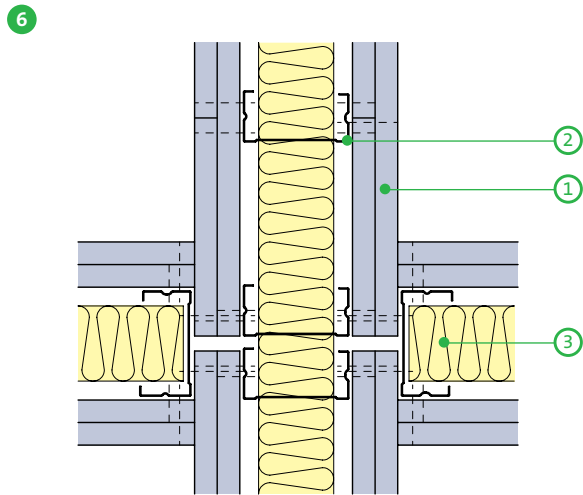
- 7 Isover Insulation



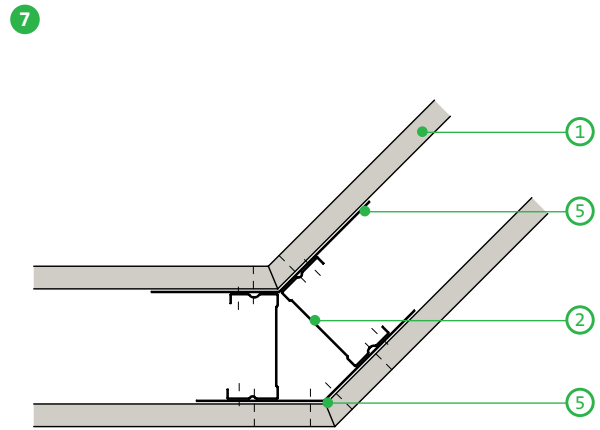
'T' junction to optimise acoustic performance and reduce flanking transmission



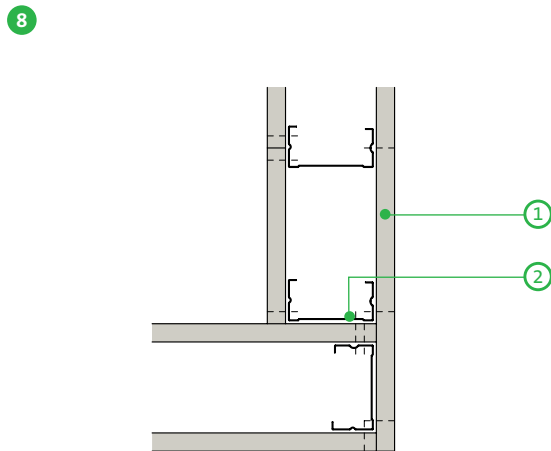
'T' junction to optimise acoustic performance and reduce flanking transmission



Four way junction to optimise acoustic performance and reduce flanking transmission



Splayed corner



Corner detail - single layer

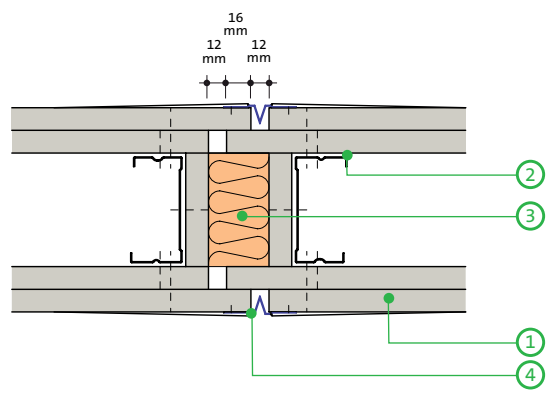


Corner detail - double layer

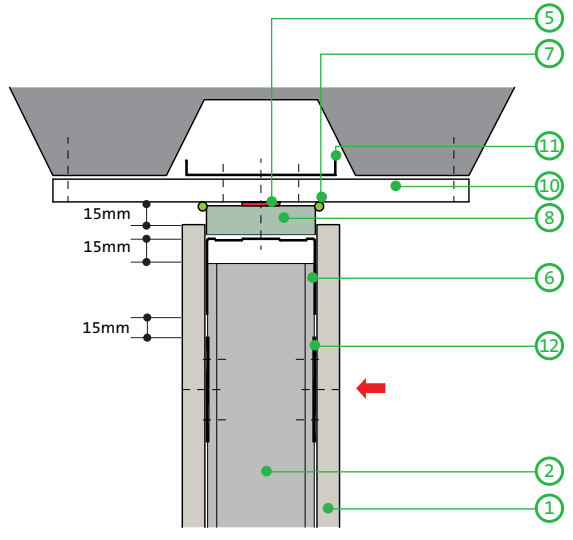
- 1 Gyproc plasterboard
- 2 Gypframe 'C' Stud
- 3 Isover insulation

- 4 Gypframe GA5 Internal Fixing Angle
- 5 Gypframe GA6 Splayed Angle

10

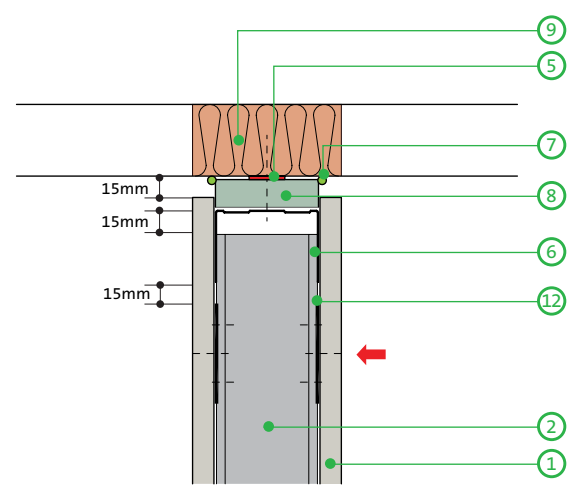


11



Deflection head parallel to floor profile for 15mm downward movement and up to 60 minutes fire resistance<sup>1</sup>  
- BS 476 Part 22: 1987

12



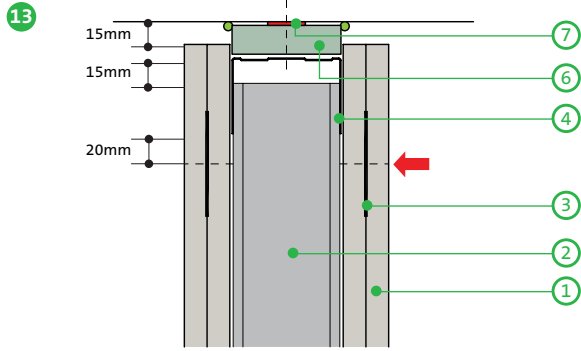
Deflection head perpendicular to floor profile for 15mm downward movement and up to 60 minutes fire resistance  
- BS 476 Part 22: 1987

- 1 Gyproc plasterboard
- 2 Gypframe 'C' Stud
- 3 Stone mineral wool (minimum density 23kg/m<sup>3</sup>) (by others)
- 4 Gyproc Control Joint
- 5 Gyproc FireStrip (continuous line)
- 6 Gypframe Deep Flange Floor & Ceiling Channels (DC)
- 7 Gyproc Sealant

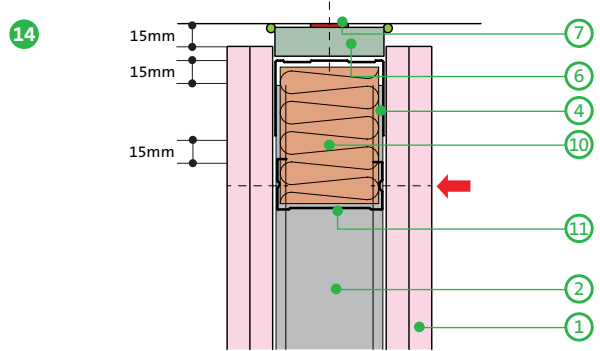
- 8 Gyproc CoreBoard
- 9 Fire-stopping (by others)
- 10 Glasroc F FIRECASE
- 11 Gypframe 99 FC 50 Fixing Channel
- 12 Gypframe GFS1 Fixing Strap fixed to studs with Gyproc Wafer Head Drywall Screws

**NB** Installing the screw into the side of the Gypframe Service Support Plate and the web of the Gypframe 'C' Stud will avoid creating excessive distortion to the lining board. No fixings should be made through the boards into the flanges of the head channel. The arrow (←) denotes the position of the uppermost board fixing, which should be made into Gypframe GFS1 Fixing Strap. Continuous Gyproc FireStrip must be installed as shown to maintain fire performance.

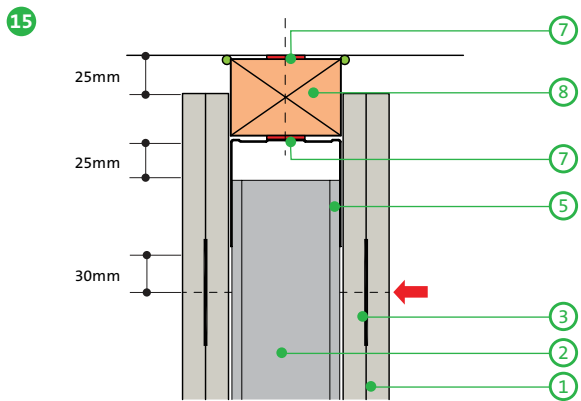
<sup>1</sup> To minimise acoustic downgrade, install Isover insulation within the hollow rib void.



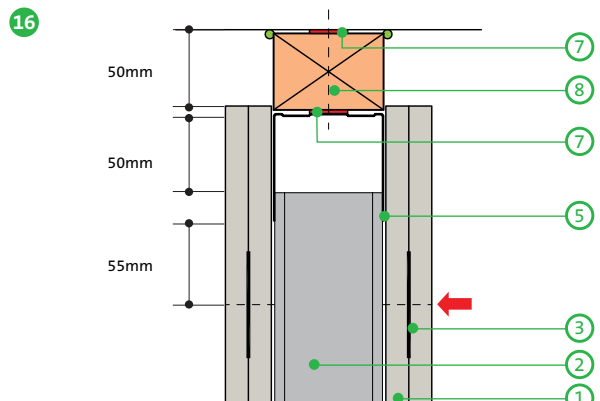
Deflection head for 15mm downward movement and 60 minutes fire resistance - BS 476 Part 22: 1987



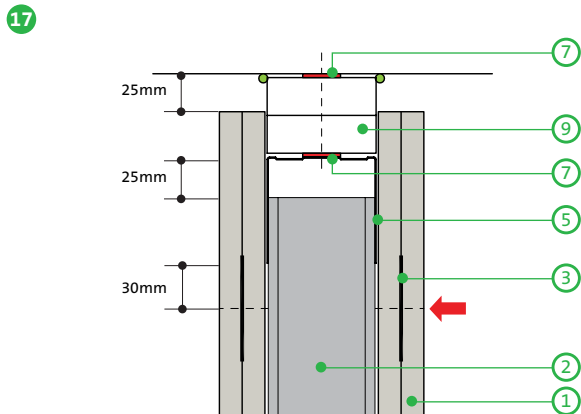
Deflection head for 15mm downward movement and up to 120 minutes fire resistance - BS 476 Part 22: 1987



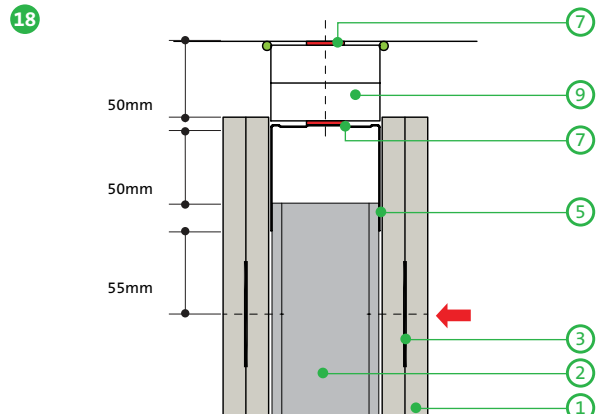
Deflection head for plus or minus 25mm movement and 60 minutes fire resistance - BS 476 Part 22: 1987



Deflection head for 50mm downward movement and 60 minutes fire resistance - BS 476 Part 22: 1987



Deflection head for plus or minus 25mm movement and 60 minutes fire resistance - BS 476 Part 22: 1987

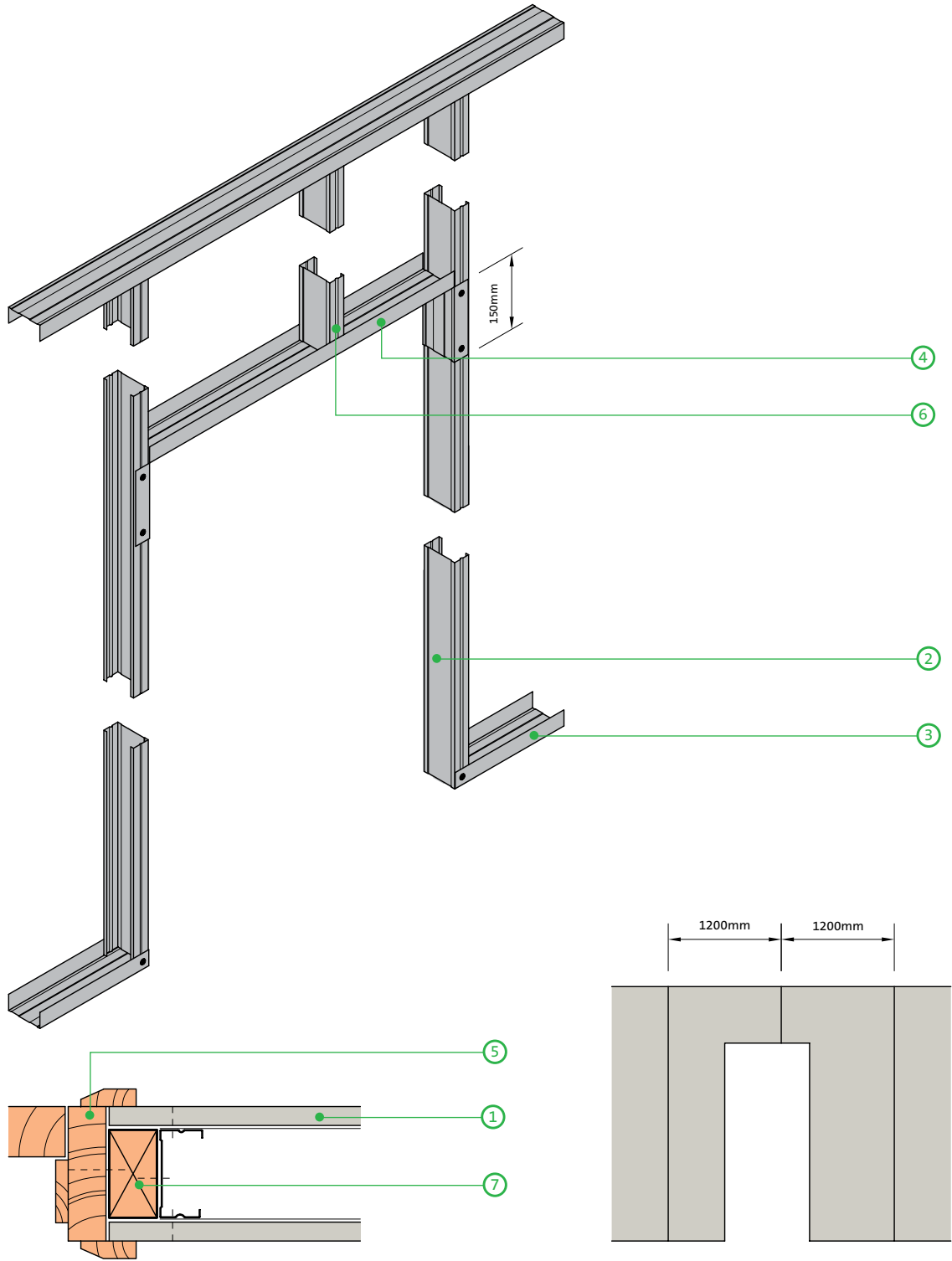


Deflection head for 50mm downward movement and 60 minutes fire resistance - BS 476 Part 22: 1987

- 1 Gyproc plasterboard
- 2 Gypframe 'C' Stud
- 3 Gypframe GFS1 Fixing Strap
- 4 Gypframe Deep Flange Floor & Ceiling Channel
- 5 Gypframe Extra Deep Flange Floor & Ceiling Channel
- 6 Gyproc CoreBoard

- 7 Gyproc FireStrip (continuous)
- 8 Timber head plate suitably fixed to structure
- 9 25mm Glasroc F FIRECASE
- 10 Stone mineral wool (by others)
- 11 Nogging cut from Gypframe 'C' Stud

**NB** No fixings should be made through the boards into the flanges of the head channel. The arrow (➡) denotes the position of the uppermost board fixing, which should be made into Gypframe GFS1 Fixing Strap (or stud nogging in construction detail 14). Continuous Gyproc FireStrip must be installed as shown to maintain fire performance. Where there is a need for a deflection head in a 90 minute wall, the 120 minute solution can be used (refer to construction detail 16) or alternatively, please contact the Gyproc Technical Department for further guidance.

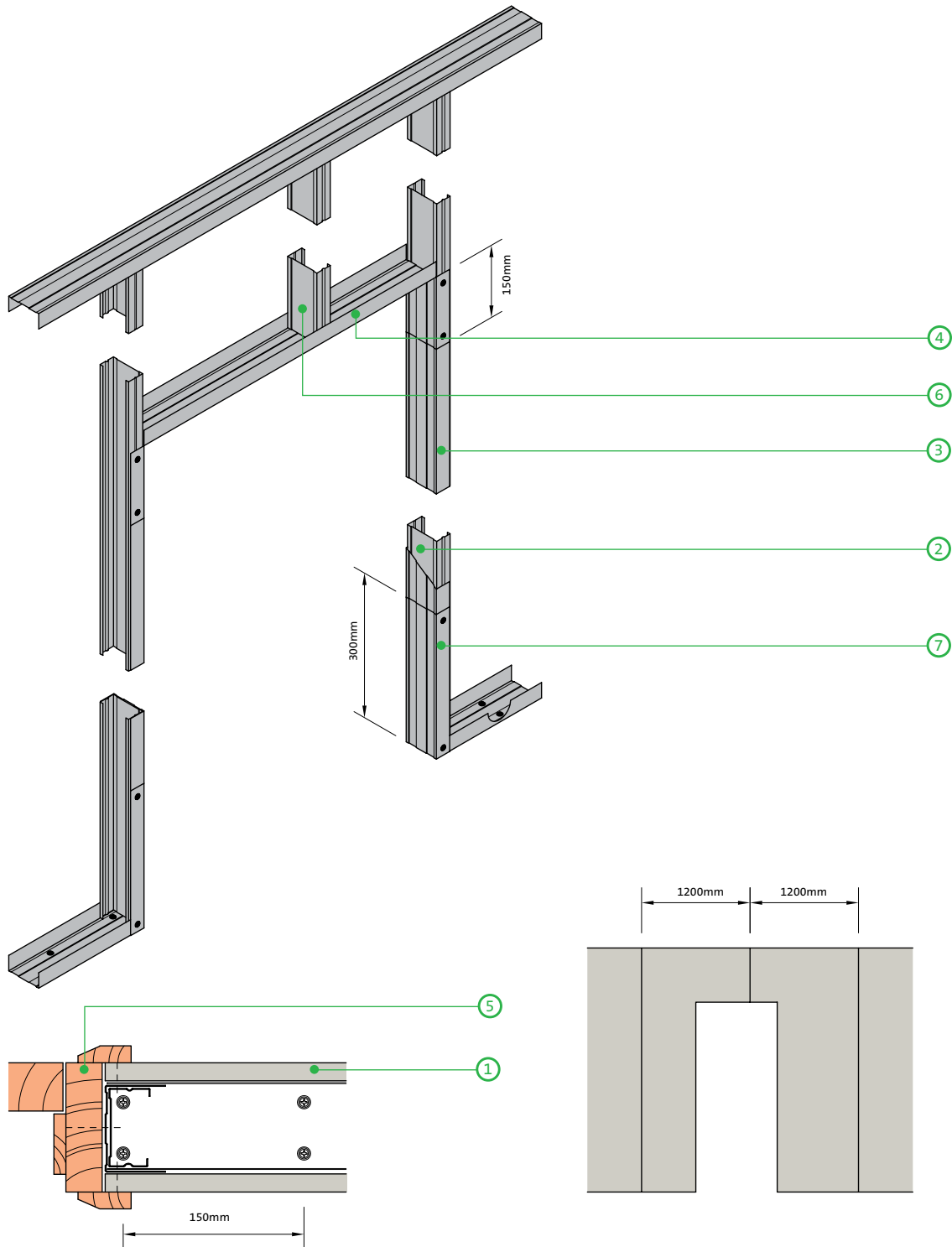


Door frame (maximum 1200mm width) to satisfy BS 5234: Parts 1 & 2: 1992 - Light and Medium Duty (up to 35kg door)

- |   |   |
|---|---|
| 1 Gyproc plasterboard   | 5 Timber door frame and architrave          |
| 2 Gypframe 'C' Stud   | 6 Gypframe 'C' Stud to maintain stud module |
| 3 Gypframe Floor & Ceiling Channel                                | 7 Timber sub-frame                          |
| 4 Gypframe Floor & Ceiling Channel cut and bent to form door head |   |

**NB** Advice should be sought from the door manufacturer prior to the construction of these details.

20



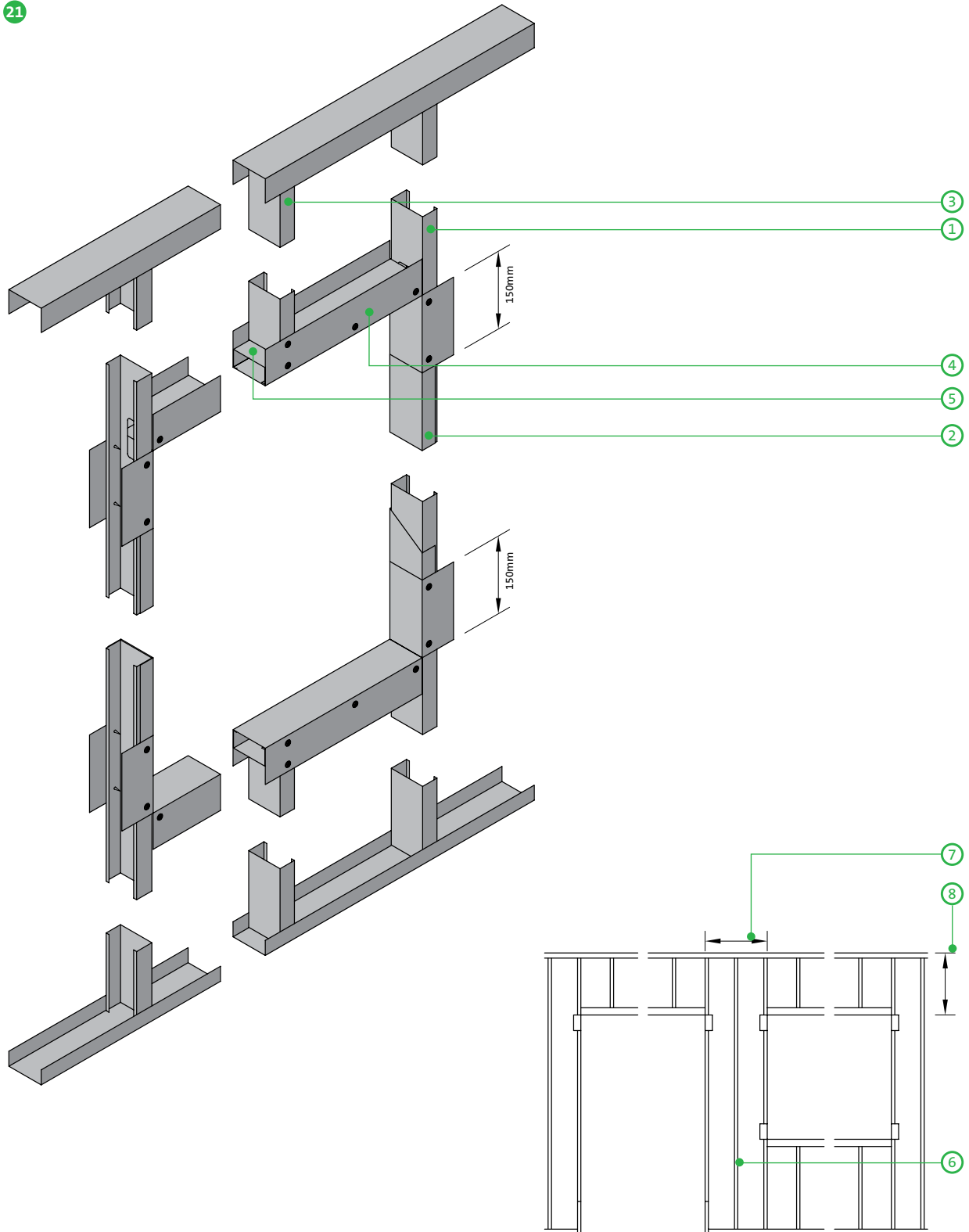
Door frame (maximum 1200mm width) to satisfy BS 5234: Parts 1 & 2: 1992 - Heavy and Severe Duty (up to 60kg door)

- |   |  |
|---|--|
| 1 Gyproc plasterboard   | 5 Timber door frame and architrave                                 |
| 2 Gypframe 'C' Stud   | 6 Gypframe 'C' Stud to maintain stud module                        |
| 3 Gypframe Floor & Ceiling Channel to sleeve studs                | 7 Gypframe Floor & Ceiling Channel cut and bent to extend up studs |
| 4 Gypframe Floor & Ceiling Channel cut and bent to form door head |  |

**NB** Advice should be sought from the door manufacturer prior to the construction of these details.

**NB** At the base, the channel is cut and bent to extend 300mm up the studs and fixed each side with two Gyproc Wafer Head Drywall Screws. The studs each side of the opening are sleeved full height of opening with Gypframe Floor & Ceiling Channel.

21

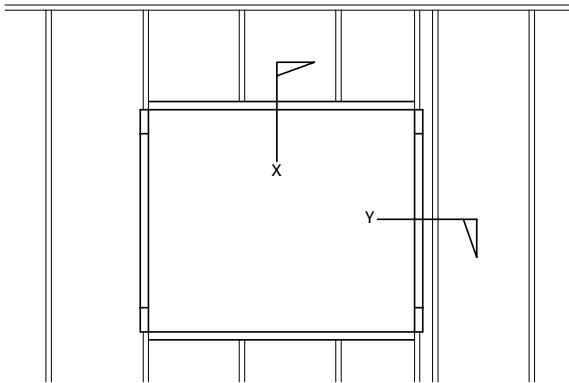


Openings 1201 - 3300mm wide, for example double doors or large windows

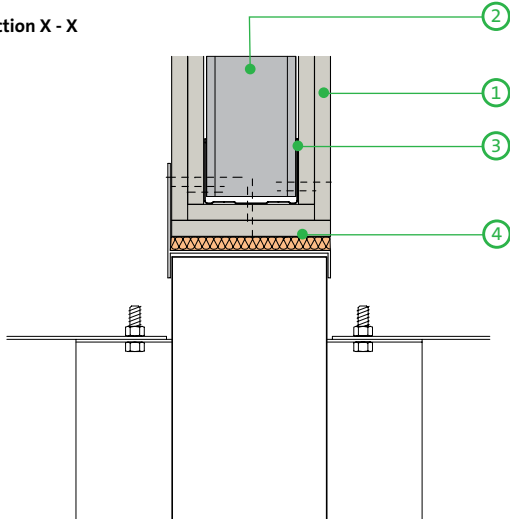
- 1 Gypframe 'C' Stud
- 2 Stud sleeved to full opening height with Gypframe Floor & Ceiling Channel
- 3 Gypframe studs (appropriate to system)
- 4 Gypframe Extra Deep Flange Floor & Ceiling Channel
- 5 Gypframe stud insert
- 6 Centre stud required for margin up to 600mm between openings
- 7 Partition between openings, minimum 600mm for Gypframe 'C' Studs (minimum 300mm for Gypframe 'T' Studs)
- 8 Maximum distance 2400mm (if exceeds 2400mm contact Gyproc Technical Department)

22

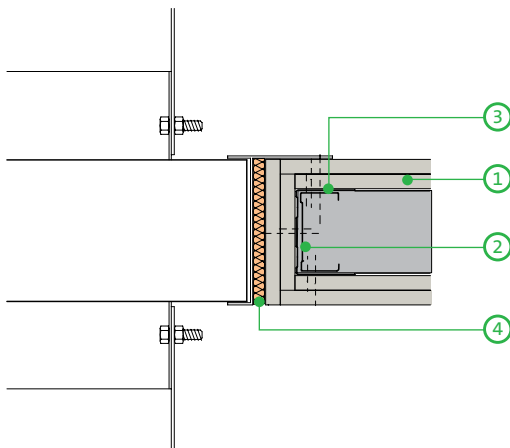
Elevation



Section X - X

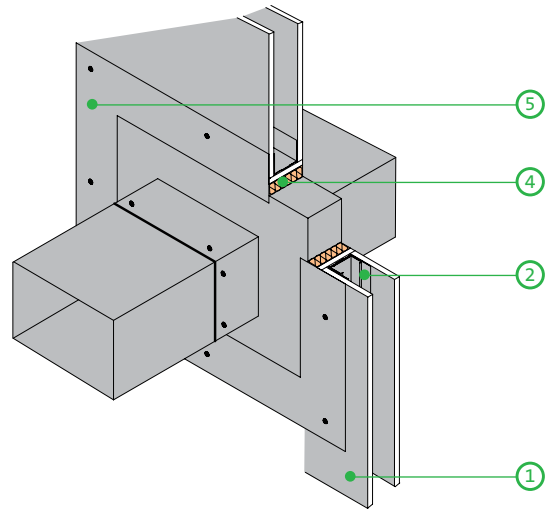


Section Y - Y



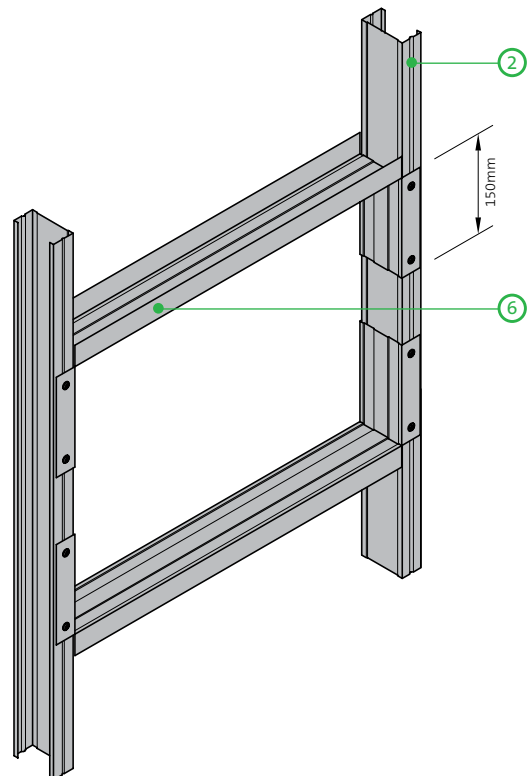
Opening for service penetrations in fire-rated partitions

23



Fire tested construction in which the damper is supported by the partition (isometric view)

24

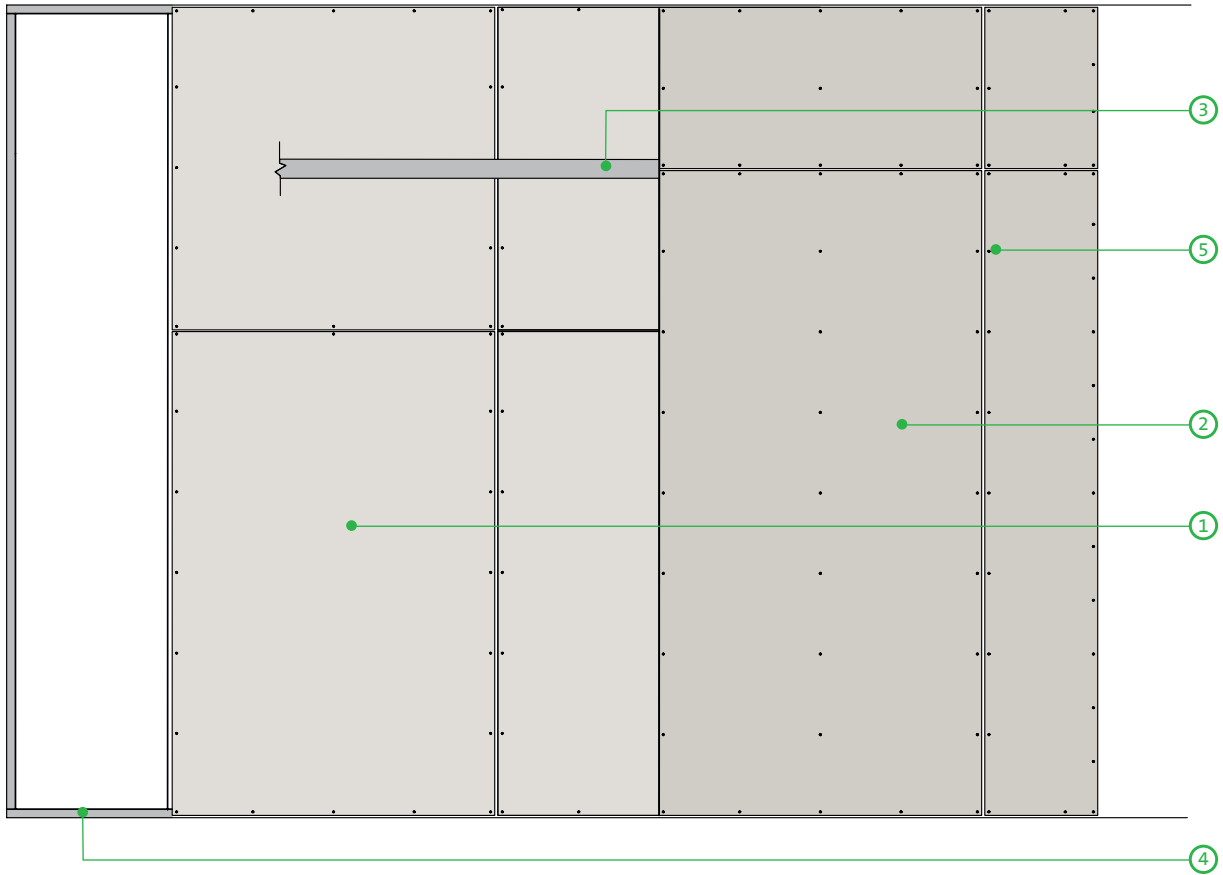


Opening up to 600mm wide for services

- 1 Gyproc plasterboard
- 2 Gypframe 'C' Stud
- 3 Gypframe Floor & Ceiling Channel
- 4 Penetration seal if required (refer to damper manufacturer for details)

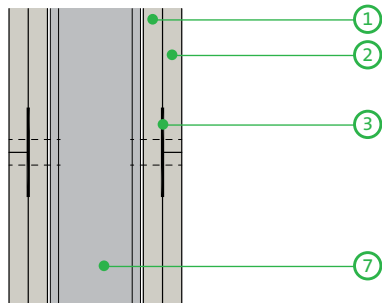
- 5 Damper (by others). Weight of damper should not exceed 57kg. Size of damper should not exceed 1400 x 1200mm
- 6 Gypframe Folded Edge Standard Floor & Ceiling Channel cut and bent to form opening head and sill

25



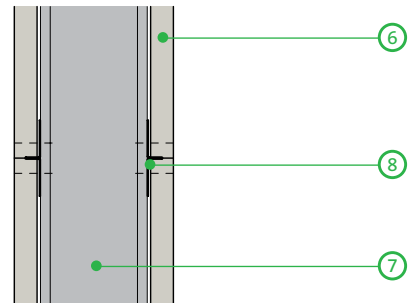
Board layout - typical configuration

26



Horizontal board joint - double layer

27



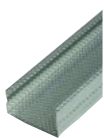
Horizontal board joint - single layer

- 1 Inner layer of Gyproc plasterboard
- 2 Outer layer of Gyproc plasterboard
- 3 Gypframe GFS1 Fixing Strap
- 4 Gypframe metal framing

- 5 Gyproc Drywall Screws or High Performance Screws
- 6 Gyproc plasterboard
- 7 Gypframe 'C' Stud
- 8 Gypframe GFT1 Fixing T (alternatively use Gypframe GSF1 Fixing Strap)

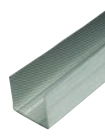
# GypWall system components

## Gypframe metal components



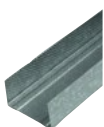
### Gypframe 'C' Studs (70 S 50, 70 S 60)

Vertical stud providing acoustic and structural performances designed to receive fixing of board to both sides.



### Gypframe Extra Deep Flange Floor & Ceiling Channels (72 EDC 80)

Floor and ceiling channels with extra deep flanges for retaining the Gypframe studs at floor and ceiling junctions for partitions over 8000mm high. Also used around openings and in deflection heads (maximum 50mm deflection).



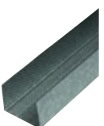
### Gypframe Folded Edge Standard Floor & Ceiling Channels (72 FEC 50)

Standard floor and ceiling channels for retaining the Gypframe studs at floor and ceiling junctions and around openings to heights not exceeding 4200mm.



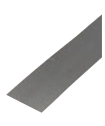
### Gypframe 99 FC 50 Fixing Channel

A versatile metal fixing channel used to support medium weight fixtures on walls.



### Gypframe Deep Flange Floor & Ceiling Channels (72 DC 80)

Floor and ceiling channels with deep flanges for retaining the Gypframe studs at floor and ceiling junctions for partitions 4200mm to 8000mm high. Also used around openings and in deflection heads (maximum 30mm deflection).



### Gypframe GFS1 Fixing Strap

Used to support horizontal board joints and within deflection heads.

## Board products



### Gyproc Habito

Gypsum plasterboard with a reinforced core providing enhanced sound insulation, impact resistance and fixing capability.



### Gyproc SoundBloc<sup>1</sup>

Gypsum plasterboard with a high density core for enhanced sound insulation performance.



### Gyproc FireLine<sup>1</sup>

Gypsum plasterboard with fire resistant additives.

## Fixing products



### Gyproc High Performance Drywall Screws

Corrosion resistant high performance screws designed for fixing Gyproc Habito plasterboard to metal and timber framing systems.



### Habito Winged Screw

The Gyproc Habito Winged screw is specifically used for Gyproc Habito installation on both Timber & Metal Stud. The wings at the tip of the screw burrow into Habito to allow the screw to sit flush with the board every time.

<sup>1</sup> Also available in a Moisture Resistant (MR) version. MR boards are specified in intermittent wet use areas.

## GypWall system components (continued)

### Plasterboard accessories

---

**Gyproc Jointing Materials**

Jointing compounds, ready mixes and adhesives for reinforcement and finishing of board joints.

**Gyproc Sealant**

Used to seal air paths for optimum sound insulation.

**Gyproc FireStrip**

A soft extruded linear intumescent gap sealer to maintain fire resistance located directly to the underside of the soffit when forming a deflection head.

**Gyproc Paper Joint Tape**

A paper tape designed for reinforcement of flat joints or internal angles.

**Gyproc Control Joint**

To accommodate structural movement of up to 7mm.

**Gyproc Drywall Primer**

Used to prepare for painting.  
Tub contents 10 litre.



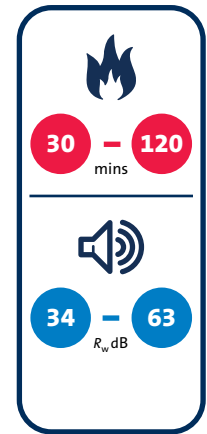
# Non-loadbearing timber stud

Traditional stud partitions



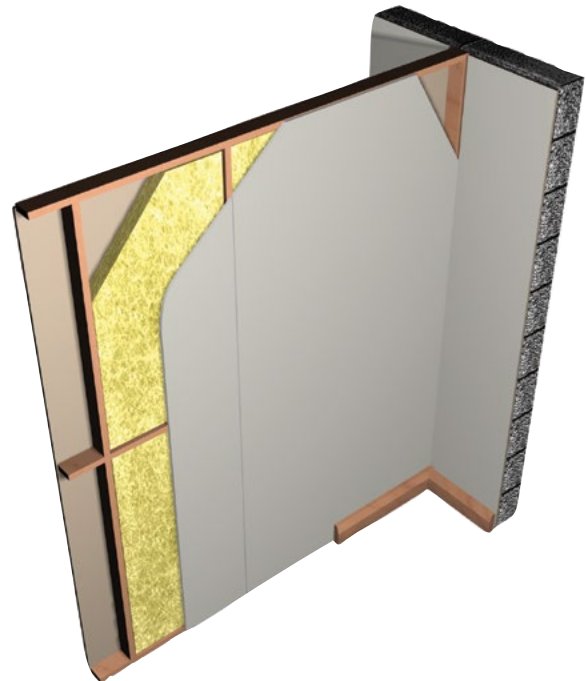
## Non-loadbearing timber stud

Timber stud partitions provide basic space division where speed of installation is considered to be a lower priority. A wide range of performances are available depending upon the specification of Gyproc linings, Gypframe metal components and Isover insulation.



### Key benefits

- High levels of acoustic performance are achievable through the use of a range of upgrades to the basic timber framework including Gypframe RB1 Resilient Bar, Gyproc SoundBloc and Isover Acoustic Roll
- Can achieve up to 2 hours fire resistance through the use of Gyproc FireLine plasterboard



### You may also be interested in...

#### GypWall QUIET

If you're looking for solutions with a higher level of acoustic and fire performance for use as a separating wall in a residential building, or other more onerous situations

- ▶ Refer to C04. S07. P219 – **GypWall QUIET**.

If you're looking for a Duty Rating in accordance with *BS 5234: Part 2: 1992*

- ▶ Refer to C04. S01. P108 – Partitions performance matrix.

# Non-loadbearing timber stud performance

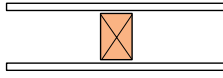
## 63mm and 75mm timber stud partitions

For details of when to specify fire resistance using EN  
 ▶ Refer to C02. S01. P18



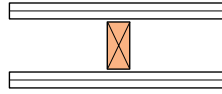
Table 1a — Solutions to satisfy the requirements of BS EN 1364-1: 1999 (Non-loadbearing)

①



One layer of board each side of timber studs at 600mm centres. Insulation and linings as in table.

②



Two layers of board each side of timber studs at 600mm centres. Insulation and linings as in table.

Detail	Partition thickness mm	Board type	Lining thickness mm	Stud size mm <sup>1</sup>	Sound insulation $R_w$ dB		System reference
					No insulation	With insulation	
<b>30 minutes fire resistance</b>							
①	88	Gyproc SoundBloc	1 x 12.5	63 x 38	-	40 <sup>2</sup>	A026009
①	93	Gyproc SoundBloc	1 x 15	63 x 38	40	-	A026008
①	93	Gyproc WallBoard	1 x 15	63 x 38	-	40 <sup>2</sup>	A026010
①	105	Gyproc WallBoard	1 x 15	75 x 38	37	40 <sup>2</sup>	A026002/6
①	105	Gyproc SoundBloc	1 x 15	75 x 38	40	43 <sup>2</sup>	A026014/17
<b>60 minutes fire resistance</b>							
②	115	Glasroc F MULTIBOARD	2 x 10	75 x 38	38	-	G106004
②	125	Gyproc FireLine	2 x 12.5	75 x 38	38	42 <sup>2</sup>	A026028/9
<b>90 minutes fire resistance</b>							
②	125	Glasroc F MULTIBOARD	2 x 12.5	75 x 38	37	-	G106005
②	135	Gyproc FireLine	2 x 15	75 x 38	38	42 <sup>2</sup>	A026030/1

▶ For further assistance in choosing the right solution for your project, try our System Selector; an online tool that enables quick and easy filtering by performance criteria. It provides system specific information downloads including BIM (Revit) objects. Go to [gyproc.ie](http://gyproc.ie)

<sup>1</sup> Stud sizes quoted are minimum.

<sup>2</sup> 25mm Isover Acoustic Roll insulation.

**NB** The fire resistance and sound insulation performances are for imperforate partitions, walls and ceilings incorporating boards with all joints taped and filled, or skimmed according to Gyproc's recommendations. The quoted performances are achieved only if Gyproc and Isover components are used throughout, and the Company's fixing recommendations are strictly observed. Any variation in the specifications should be checked with Gyproc.

**NB** The maximum substantiated height when a fire resistance is required is 3000mm, for any heights greater than this please contact our Technical Department.

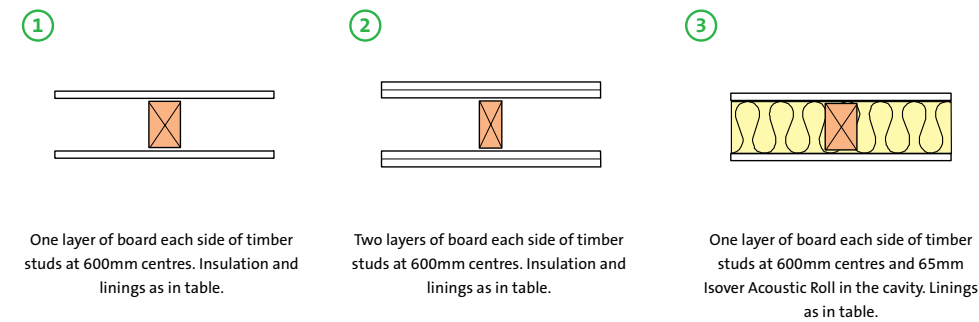
## Non-loadbearing timber stud performance (continued)

### 63mm, 75mm and 100mm timber stud partitions

For details of when to specify fire resistance using BS  
 ▶ Refer to C02. S01. P18



Table 1b — Solutions to satisfy requirements of BS 476: Part 22: 1987 (Non-loadbearing)



Detail	Partition thickness mm	Board type	Lining thickness mm	Stud size mm <sup>1</sup>	Sound insulation $R_w$ dB		System reference
					No insulation	With insulation	
<b>30 minutes fire resistance</b> (BS)							
①	88	Gyproc SoundBloc	1 x 12.5	63 x 38	-	40 <sup>2</sup>	A026009
③	88	Gyproc WallBoard	1 x 12.5	63 x 38	-	41	A026012
①	93	Gyproc SoundBloc	1 x 15	63 x 38	40	-	A026008
①	93	Gyproc WallBoard	1 x 15	63 x 38	-	40 <sup>2</sup>	A026010
①	100	Gyproc WallBoard	1 x 12.5	75 x 38	35	36 <sup>2</sup>	A026001/005
①	100	Gyproc SoundBloc	1 x 12.5	75 x 38	38	40 <sup>2</sup>	A026011/016
①	105	Gyproc SoundBloc	1 x 15	75 x 38	40	43 <sup>2</sup>	A026014/017
<b>60 minutes fire resistance</b> (BS)							
①	100	Glasroc F MULTIBOARD	1 x 12.5	75 x 50	34	-	G106003
②	115	Glasroc F MULTIBOARD	2 x 10	75 x 50	38	-	G106004
②	125	Gyproc WallBoard	2 x 12.5	75 x 38	38	42 <sup>2</sup>	A026003/007
②	125	Gyproc SoundBloc	2 x 12.5	75 x 38	44	46 <sup>2</sup>	A026015/018
①	130	Gyproc FireLine	1 x 15	100 x 50	38	-	A026023
<b>90 minutes fire resistance</b> (BS)							
②	125	Glasroc F MULTIBOARD	2 x 12.5	75 x 38	37	-	G106005
<b>120 minutes fire resistance</b> (BS)							
②	160	Gyproc FireLine	2 x 15	100 x 50	41	-	A026025

▶ For further assistance in choosing the right solution for your project, try our System Selector; an online tool that enables quick and easy filtering by performance criteria. It provides system specific information downloads including BIM (Revit) objects. Go to [gyproc.ie](http://gyproc.ie)

<sup>1</sup> Stud sizes quoted are minimum.

<sup>2</sup> 25mm Isover Acoustic Roll insulation.

**(NB)** The fire resistance and sound insulation performances are for imperforate partitions, walls and ceilings incorporating boards with all joints taped and filled, or skimmed according to Gyproc's recommendations. The quoted performances are achieved only if Gyproc and Isover components are used throughout, and the Company's fixing recommendations are strictly observed. Any variation in the specifications should be checked with Gyproc.

## Non-loadbearing timber stud performance (continued)

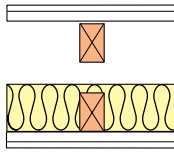
### 75mm and 89mm timber stud walls

For details of when to specify fire resistance using EN  
 ▶ Refer to C02. S01. P18



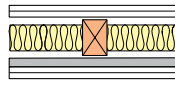
Table 2a — Solutions to satisfy the requirements of BS EN 1364-1: 1999 (Non-loadbearing)

①



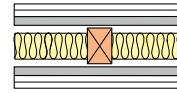
Two separate timber frames spaced 50mm apart, consisting of 89mm x 38mm timber studs at 600mm centres with noggings. Two layers of board each side. 100mm Isover Acoustic Roll between the studs on one side. Linings as in table.

②



Two layers of board each side of 75mm x 38mm timber studs at 600mm centres with Gypframe RB1 Resilient Bars fixed horizontally to one side at 600mm centres. 50mm Isover Acoustic Roll in the cavity. Linings as in table.

③



Two layers of board each side of 75mm x 38mm timber studs at 600mm centres with Gypframe RB1 Resilient Bars fixed horizontally to both sides at 600mm centres. 50mm Isover Acoustic Roll in the cavity. Linings as in table.

Detail	Partition thickness mm	Board type	Lining thickness mm	Stud size mm	Sound insulation $R_w (R_w + C_{tr})$ dB	System reference
<b>60 minutes fire resistance</b>						
②	141	Gyproc SoundBloc	2 x 12.5	75 x 38	56 (48)	A046005
③	157	Gyproc SoundBloc	2 x 12.5	75 x 38	59 (51)	A046006
①	293	Gyproc Plank + Gyproc FireLine	1 x 19 + 1 x 12.5	89 x 38	63 (51)	A036003

▶ For further assistance in choosing the right solution for your project, try our System Selector; an online tool that enables quick and easy filtering by performance criteria. It provides system specific information downloads including BIM (Revit) objects. Go to [gyproc.ie](http://gyproc.ie)

**NB** The fire resistance and sound insulation performances are for imperforate partitions, walls and ceilings incorporating boards with all joints taped and filled, or skimmed according to Gyproc's recommendations. The quoted performances are achieved only if Gyproc and Isover components are used throughout, and the Company's fixing recommendations are strictly observed. Any variation in the specifications should be checked with Gyproc.

**NB** The maximum substantiated height when a fire resistance is required is 3000mm, for any heights greater than this please contact our Technical Department.

## Non-loadbearing timber stud performance (continued)

### 75mm and 89mm timber stud walls

For details of when to specify fire resistance using BS  
 ▶ Refer to C02. S01. P18



Table 2b — Solutions to satisfy requirements of BS 476: Part 22: 1987 (Non-loadbearing)

Detail	Partition thickness mm	Board type	Lining thickness mm	Stud size mm	Sound insulation $R_w (R_w + C_{tr})$ dB	System reference
<b>60 minutes fire resistance</b> <b>BS</b>						
③	141	Gyproc SoundBloc	2 x 12.5	75 x 38	56 (48)	A046005
④	157	Gyproc SoundBloc	2 x 12.5	75 x 38	59 (51)	A046006
②	290	Gyproc SoundBloc <sup>1</sup>	2 x 15	89 x 38	61 (53)	A036002
①	293	Gyproc Plank + Gyproc WallBoard	1 x 19 + 1 x 12.5	89 x 38	63 (51)	A046022
<b>90 minutes fire resistance</b> <b>BS</b>						
③	151	Gyproc SoundBloc	2 x 15	75 x 38	58 (51)	A046007
④	167	Gyproc SoundBloc	2 x 15	75 x 38	60 (52)	A046008
④	170	Gyproc Plank + Gyproc SoundBloc	1 x 19 + 1 x 12.5	75 x 38	60 (52)	A046024

▶ For further assistance in choosing the right solution for your project, try our System Selector; an online tool that enables quick and easy filtering by performance criteria. It provides system specific information downloads including BIM (Revit) objects. Go to [gyproc.ie](http://gyproc.ie)

<sup>1</sup> Test conducted to BS 476: Part 21: 1987 (loadbearing)

**NB** The fire resistance and sound insulation performances are for imperforate partitions, walls and ceilings incorporating boards with all joints taped and filled, or skimmed according to Gyproc's recommendations. The quoted performances are achieved only if Gyproc and Isover components are used throughout, and the Company's fixing recommendations are strictly observed. Any variation in the specifications should be checked with Gyproc.

# Non-loadbearing timber stud design

## Planning – key factors

The position of services and heavy fixtures should be pre-determined and their installation planned into the frame erection stage. If a plastered finish is specified, the thickness of the door or glazing frame must allow for the thickness of the plaster finish.

To minimise the risk of cracking at the plasterboard joints, seasoned timber with a moisture content not exceeding that recommended in BS 5268 should be used. The contractor should ensure that timber supports are accurately spaced, aligned, and levelled.

## Cavity fire barriers

Where required to maintain fire performance, suitable fire stopping (by others) should be installed full filled within the partition cavity to form a suitable closure.

► Refer to C06. S06. P422 – Cavity fire barriers.

## Services

### Penetrations

Penetrations of fire resistant constructions for services need careful consideration to ensure that the integrity of the element is not impaired and also that the services themselves do not act as the mechanism of fire spread.

► Refer to C02. S01. P41 – Service installations.

### Electrical

Electrical and other small service runs can be routed within the timber stud cavity. The installation of electrical services should be carried out in accordance with BS 7671. Switch boxes and socket outlets can be supported from timber stud noggings.

## Strength and robustness

Timber should be aligned and level, and should meet the requirements of BS 5268. The dimensions and assembly of timber supports should be sufficient to allow positive fixing of plasterboard without bounce or undue deflection. When the above fixing conditions cannot be met, a timber batten should be securely fixed to the side of the timber support to increase the bearing surface.

Where boards are fixed at maximum centres in adverse conditions, the standard of lining can be affected. Adverse conditions can generally be described as conditions where high humidity occurs, principally in the cold, damp, autumn / winter period. They also refer to buildings under construction over this period, where both the structure and wet applications, such as plastering and screeding, are subject to slow drying conditions (refer to table 3).

**Table 3 – Gyproc plasterboard or Glasroc F specialist board fixed direct to timber supports**

Board type	Thickness mm	Width mm	Maximum recommended stud centres mm
Gyproc WallBoard	12.5	900	450
		1200	600
	15	900	450
		1200	600
Gyproc FireLine	12.5	900	450
		1200	600
	15	900	450
		1200	600
Gyproc Plank	19	600	600
Gyproc SoundBloc	12.5	1200	600
	15	1200	600
Glasroc F MULTIBOARD	10	1200	600
	12.5	1200	600

## Partition junctions

At a 'T' junction, a ladder frame should be constructed between studs to provide fixing points for the abutting partition, and to support the lining (refer to construction detail 2). The horizontal members of the frame should be at 600mm maximum centres.

## Fixing to super-dried timber

It has been established by test that Gyproc Drywall Screws are the preferred solution for fixing to standard softwood or superdried timber (approximately 12% moisture content).

## Nail popping

Loosening of nails in timber can occur through timber shrinkage, or as a result of fixing boards to misaligned or twisted framing.

To reduce the risks, boards should be fixed tight to framing members, using Gyproc Drywall Screws.

## Non-loadbearing timber stud design (continued)

### Fixtures

Lightweight fixtures can be made directly to the partitions. Medium weight, or heavyweight fixtures such as cisterns, radiators or wash basins, can be made directly into the timber supports.

Additional studs or timber noggings should be installed as appropriate.

### Board finishing

► Refer to C08. S01. P483 – Finishes.

### Tiling

Tiles up to 32kg/m<sup>2</sup> can be applied to the surface of lightweight partition systems.

► Refer to C08. S04. P498 – Tiling.

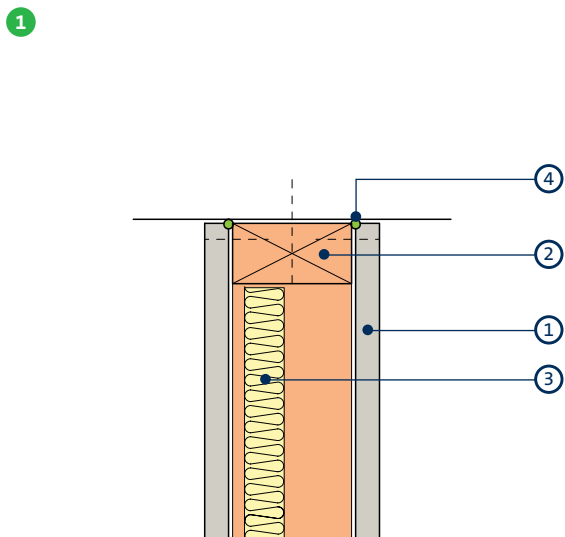


### Important information

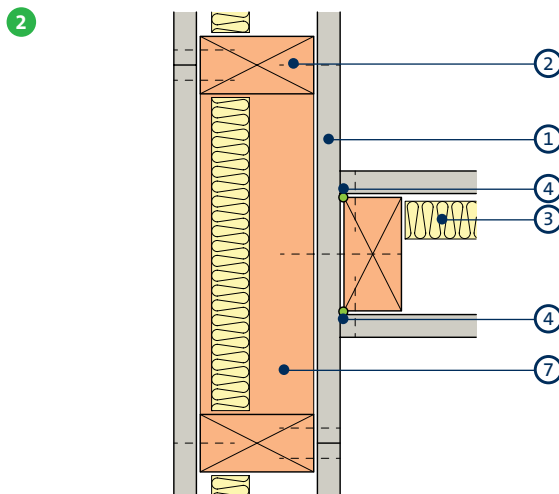
Ensure Gyproc Drywall Screws have a minimum of 25mm penetration into the timber frame.

When using Gypframe RB1 Resilient Bar specifications, screw length selection is critical. Ensure the size of Gyproc Drywall Screws selected to fix the lining to the Gypframe RB1 Resilient Bar do not penetrate the timber frame and therefore compromise the partition's acoustic performance.

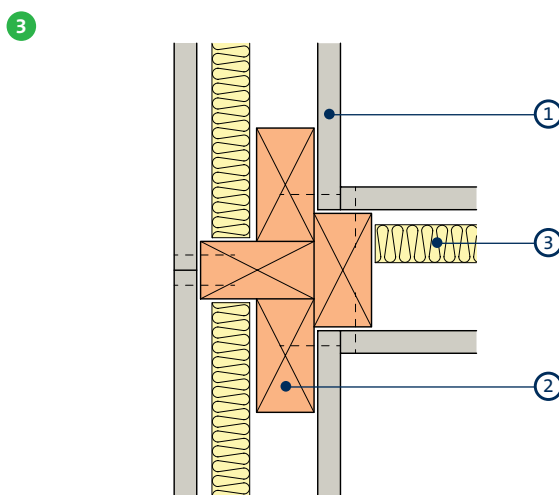
# Non-loadbearing timber stud construction details



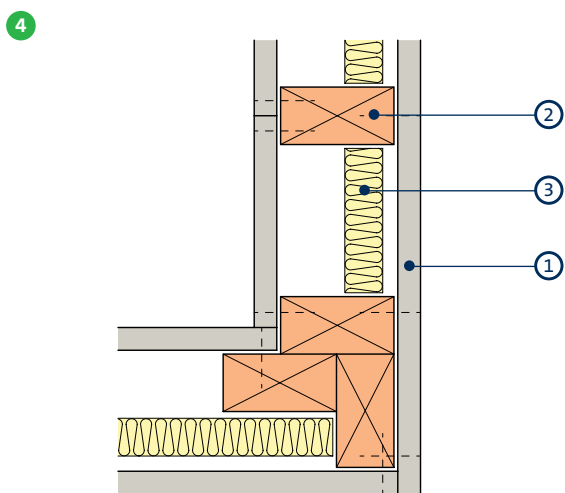
Head and base



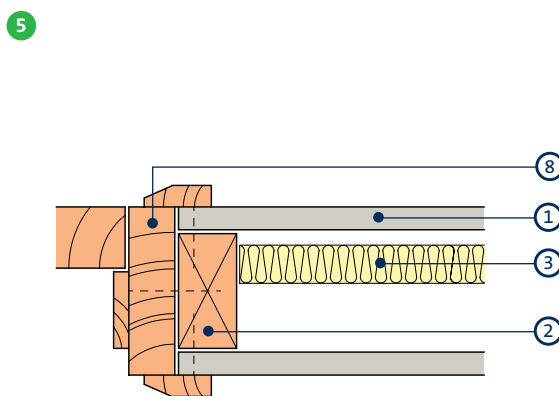
'T' junction between studs



'T' junction at stud



Internal / external corner



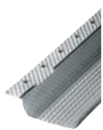
Door jamb

- 1 Gyproc plasterboard
- 2 Timber framing
- 3 Isover insulation
- 4 Gyproc Sealant

- 5 Bulk fill with Gyproc jointing materials (where gap exceeds 5mm)
- 6 Skirting
- 7 Timber noggings at 600mm centres
- 8 Timber door frames and architrave

# Non-loadbearing timber stud system components

## Gypframe metal components



### Gypframe RB1 Resilient Bar

Acoustically engineered channel to separate board fixing from the primary frame. Fixed horizontal to face of studs.

### Timber (by others)

Typically 63mm to 100mm depth; 30mm to 50mm width.

## Board products (continued)



### Gyproc WallBoard

Standard gypsum plasterboard.



### Gyproc Plank

Standard gypsum plasterboard located as an inner layer.



### Gyproc DuraLine<sup>1</sup>

Gypsum plasterboard with fire resistant additives and a high density core for enhanced sound insulation and impact resistance performance.



### Gyproc Moisture Resistant

Gypsum plasterboard with moisture resistant additives in the core and special green lining paper for easy recognition. Used as outer layer.



### Glasroc F MULTIBOARD

Non-combustible glass-reinforced gypsum board.



### Gyproc FireLine<sup>1</sup>

Gypsum plasterboard with fire resistant additives.



### Glasroc H TILEBACKER

Non-combustible glass-reinforced gypsum board with a water resistant pre-primed acrylic coating to receive tiling.



### Gyproc SoundBloc<sup>1</sup>

Gypsum plasterboard with a high density core for enhanced sound insulation performance.

<sup>1</sup> Also available in a Moisture Resistant (MR) version. MR boards are specified in intermittent wet use areas.

## Fixing products



### Gyproc Drywall Screws

Corrosion resistant self-tapping steel screws for fixing board-to-timber and board-to-metal framing less than 0.8mm thick



### Gyproc Collated Drywall Screws

Corrosion resistant self-tapping steel screws for fixing board-to-timber and board-to-metal framing less than 0.8mm thick.

## Non-loadbearing timber stud components (continued)

### Plasterboard accessories



#### Gyproc Jointing Material

Jointing compounds, ready mixes and adhesives for reinforcement and finishing of board joints.



#### Gyproc Sealant

Used to seal air paths for optimum sound insulation.



#### Gyproc Corner Tape

A paper tape bonded to two corrosion resistant steel strips.



#### Gyproc Drywall Primer

Used to prepare for painting.  
Tub contents 10 litre



#### Gyproc Paper Joint Tape

A paper tape designed for reinforcement of flat joints or internal angles.

### Finishing products



#### Gyproc Skimcoat

To provide a plaster skim finish on most common backgrounds including undercoat plasters and plasterboard. Can provide enhanced acoustic performance.



#### Gyproc Carlite Finish

To provide a plaster skim finish on most common backgrounds including undercoat plasters and plasterboard. Can provide enhanced acoustic performance.



#### Gyproc Carlite Ultra Finish

Offers all the benefits of Gyproc Skimcoat and Gyproc Carlite Finish with a reduced set time of 90-120mins, making it ideal for smaller jobs.



#### Plaster accessories

Designed for the reinforcement and finishing of board joints before plaster skimming.

### Insulation products



#### Isover Acoustic Roll

Glass mineral wool for enhanced acoustic and thermal performance.

## Non-loadbearing timber stud installation overview

This is intended to be a basic description of how the system is built.



Timber framing is fixed to the perimeter, abutments, and to frame any openings, using suitable fixings. Timber studs are fixed at specified centres.



Door openings are formed by fixing full height timber studs to each side, together with a timber head piece. Door casings are then fixed to the timber ground. Additional framing is installed as required to support heavy fixtures.



M&E services can be located within the partition cavity before the partition has been boarded. Timber noggings are fixed to support recessed switch boxes / socket outlets.



Where Gypframe RB1 Resilient Bars are required, these are fixed horizontally to the timber studs to one or both sides as specified.



Isover insulation can also be added to the partition cavity for increased acoustic performance.



The perimeter of the partition is sealed on both sides with Gyproc Sealant.



Gyproc plasterboards are screw-fixed to all timber supports with Gyproc Drywall Screws, or to the Gypframe RB1 Resilient Bars with Gyproc Drywall Screws.



Horizontal board joints are backed with timber noggings or Gypframe RB1 Resilient Bars as required.

**NB** The correct length of fixings must be used when installing the Gyproc board to the Gypframe RB1 Resilient Bars to ensure that the acoustic performance is not compromised.



### Additional information

For full installation details, refer to the **Gyproc Installation Guide**, available to download from [gyproc.ie](http://gyproc.ie)



# C05

Specialist partitions

## Specialist partitions






This section details specialist lightweight systems where high-security, curved, fire or blast resistant partitions are required



## Specialist partitions

This section contains our solutions that have performances above and beyond the usual project requirements. Examples are enhanced security, aesthetic appeal and explosion protection.

The systems included in this section are:

Specific performance	System	Description	Page
	ShaftWall	Lightweight, fire resistant structure to protect vertical or horizontal elements in confined spaces, where access is limited to one side only	C05. S02. P291
	FireWall	Lightweight wall capable of providing up to 240 minutes fire resistance	C05. S03. P321
	GypWall <b>CURVE</b>	Specifically designed to provide curved walls and linings with a high degree of design flexibility. Ideal for creating imaginative spaces with great aesthetic impact	C05. S04. P329
	GypWall <b>SECURE</b>	Lightweight security wall, offering high resistance to determined attack	C05. S05. P339
	BlastWall	High performance blast refuge system offering resistance to explosive devices	C05. S06. P343

# ShaftWall

Shaft and duct encasement system

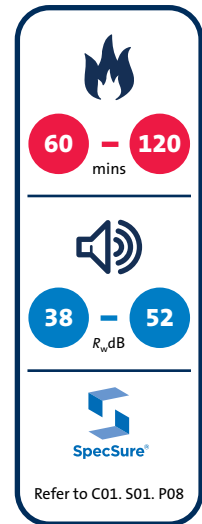


# ShaftWall

ShaftWall provides a lightweight, fire resistant structure to protect elements in confined spaces wherever access is limited to one side only.

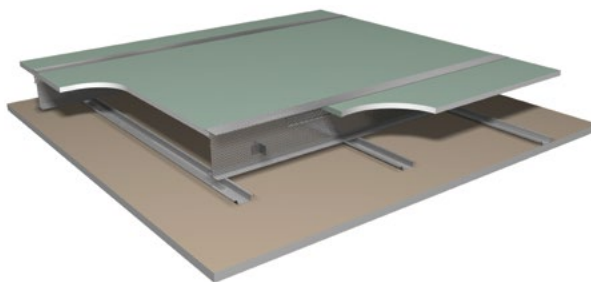
The system provides a protective structure which can be incorporated at an early stage of the construction without the need for scaffolding.

The system can also be built horizontally to provide a fire rated membrane.



## Key benefits

- Horizontal membranes are built entirely from below
- A ShaftWall variant with non-combustible Glasroc F FIRECASE board linings is available
- High level commonality with GypWall partition components, particularly 70mm stud solutions
- Higher certainty of installed acoustic performance due to laboratory tests incorporating deflection heads
- Can be used where access is limited to one side at the head, e.g. M & E cages already installed in corridors



## You may also be interested in...

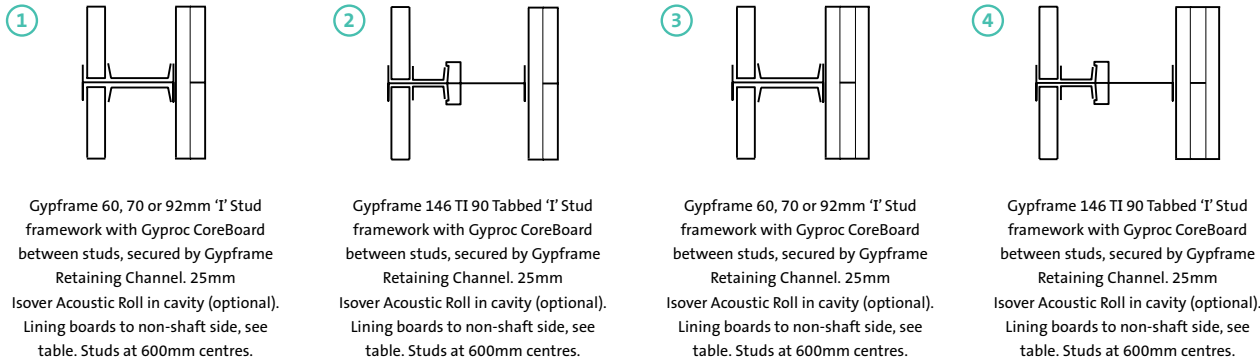
For assistance in choosing the right solution for your project, try our **System Selector**; an online tool that enables quick and easy filtering by performance criteria. It provides system specific downloads including:

- BIM (Revit) objects
- Specification Clauses
- System and product data sheets

► Refer to [gyproc.ie](http://gyproc.ie)



**Table 1a — Solutions to satisfy the requirements of BS EN 1364-1: 1999**



Detail	Partition thickness mm	Lining boards to non-shaft side <sup>1</sup>		Max. partition height <sup>2</sup> mm	Stud size mm	Sound insulation $R_w$ dB <sup>3</sup>		Duty rating <sup>5</sup>	Approx. weight kg/m <sup>2</sup>	System reference
		Board type	Lining thickness mm			No insulation	Sealed structure plus 25mm Isover Acoustic Roll <sup>4</sup>			
<b>60 minutes fire resistance</b>										
①	87	Gyproc FireLine	2 x 12.5	4400	60	40	44	Severe	39	A306002/012
①	97	Gyproc FireLine	2 x 12.5	4400	70	40	44	Severe	39	A306002/012
①	119	Gyproc FireLine	2 x 12.5	6000	92	45	47	Severe	40	A306005/014
②	173	Gyproc FireLine	2 x 12.5	6000	146	48	52	Severe	42	A306008/020
<b>90 minutes fire resistance</b>										
①	92	Gyproc FireLine	2 x 15	4500	60	42	45	Severe	43	A306003/023
①	102	Gyproc FireLine	2 x 15	4500	70	42	45	Severe	43	A306003/023
①	124	Gyproc FireLine	2 x 15	6000	92	44	46	Severe	44	A306006/025
②	178	Gyproc FireLine	2 x 15	6000	146	48	50	Severe	46	A306009/028
<b>120 minutes fire resistance</b>										
③	107	Gyproc FireLine	3 x 15	4500	60	43	45	Severe	55	A306030/035
③	117	Gyproc FireLine	3 x 15	4500	70	43	45	Severe	55	A306030/035
③	139	Gyproc FireLine	3 x 15	6000	92	45	46	Severe	56	A306031/036
④	193	Gyproc FireLine	3 x 15	6000	146	49	50	Severe	58	A306032/033

▶ For further assistance in choosing the right solution for your project, try our System Selector; an online tool that enables quick and easy filtering by performance criteria. It provides system specific information downloads including BIM (Revit) objects. Go to [gyproc.ie](http://gyproc.ie)

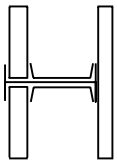
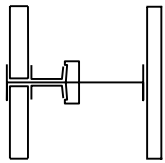
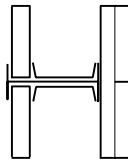
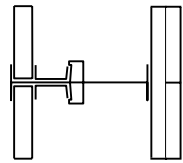
<sup>1</sup> For improved durability and impact resistance, the outer layer of Gyproc FireLine can be replaced with a layer of 15mm Glasroc F FIRECASE.  
<sup>2</sup> The maximum heights quoted are limited by the fire state field of application or by limiting deflection of L/240 at 200 Pa, whichever is the more onerous.  
<sup>3</sup> The acoustic performance figures quoted include ShaftWall partitions with deflection heads.  
<sup>4</sup> Gyproc CoreBoard and first layer of lining board are bedded onto Gyproc Sealant, as required for pressurised air shafts, in addition to normal sealing.  
<sup>5</sup> Estimated rating from non-shaft side only.

**NB** The fire resistance and sound insulation performances are for imperforate partitions, but incorporating deflection heads, with all joints taped and filled, or skimmed according to Gyproc's recommendations. The quoted performances are achieved only if Gyproc and Isover components are used throughout, and the Company's fixing recommendations are strictly observed. Any variation in the specifications should be checked with Gyproc.

**NB** Gyppframe Extra Deep Flange Floor & Ceiling Channel or Gyppframe 'J' Channel should be used at the head. For the base Gyppframe Folded Edge Standard Floor & Ceiling Channel should be used for heights up to 4200mm, Gyppframe Deep Flange Floor & Ceiling Channel should be used for heights between 4200mm and 8000mm, Gyppframe Extra Deep Flange Floor & Ceiling Channel should be used for heights in excess of 8000mm.



**Table 1b — Solutions to satisfy requirements of BS 476: Part 22: 1987**

<p>①</p> 	<p>②</p> 	<p>③</p> 	<p>④</p> 
--	--	---	--

Detail	Partition thickness mm	Lining boards to non-shaft side <sup>1</sup>		Max. partition height <sup>2</sup> mm	Stud size mm	Sound insulation $R_w$ dB <sup>3</sup>		Duty rating <sup>5</sup>	Approx. weight kg/m <sup>2</sup>	System reference
		Board type	Lining thickness mm			No insulation	Sealed structure plus 25mm Isover Acoustic Roll <sup>4</sup>			
<b>(60)/30 minutes fire resistance (BS) (exposure to fire from shaft side)</b>										
①	77	Gyproc FireLine	1 x 15	4200	60	39	42	Heavy	30	A306001/010
①	87	Gyproc FireLine	1 x 15	4200	70	39	42	Heavy	30	A306001/010
①	109	Gyproc FireLine	1 x 15	6000	92	40	43	Heavy	31	A306004/011
②	163	Gyproc FireLine	1 x 15	7700	146	43	46	Heavy	33	A306007/013
<b>(90)/60 minutes fire resistance (BS) (exposure to fire from shaft side)</b>										
①	87	Gyproc FireLine	2 x 12.5	4400	60	40	44	Severe	39	A306002/012
①	97	Gyproc FireLine	2 x 12.5	4400	70	40	44	Severe	39	A306002/012
①	119	Gyproc FireLine	2 x 12.5	6400	92	45	47	Severe	40	A306005/014
②	173	Gyproc FireLine	2 x 12.5	7900	146	48	52	Severe	42	A306008/020
<b>(120)/90 minutes fire resistance (BS) (exposure to fire from shaft side)</b>										
③	92	Gyproc FireLine	2 x 15	4500	60	42	45	Severe	43	A306003/023
③	102	Gyproc FireLine	2 x 15	4500	70	42	45	Severe	43	A306003/023
③	124	Gyproc FireLine	2 x 15	6700	92	44	46	Severe	44	A306006/025
④	178	Gyproc FireLine	2 x 15	7900	146	48	50	Severe	46	A306009/028

▶ For further assistance in choosing the right solution for your project, try our System Selector; an online tool that enables quick and easy filtering by performance criteria. It provides system specific information downloads including BIM (Revit) objects. Go to [Gyproc.ie](http://Gyproc.ie)

<sup>1</sup> For improved durability and impact resistance, the outer layer of Gyproc FireLine can be replaced with a layer of 15mm Glasroc F FIRECASE.

<sup>2</sup> Based on limiting deflection of L/240 at 200 Pa.

<sup>3</sup> The acoustic performance figures quoted include ShaftWall partitions with deflection heads.

<sup>4</sup> Gyproc CoreBoard and first layer of lining board are bedded onto Gyproc Sealant, as required for pressurised air shafts, in addition to normal sealing.

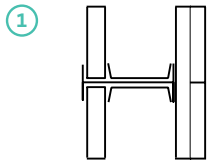
<sup>5</sup> Estimated rating from non-shaft side only.

**(NB)** The fire resistance and sound insulation performances are for imperforate partitions, but incorporating deflection heads, with all joints taped and filled, or skimmed according to Gyproc's recommendations. The quoted performances are achieved only if Gyproc and Isover components are used throughout, and the Company's fixing recommendations are strictly observed. Any variation in the specifications should be checked with Gyproc.

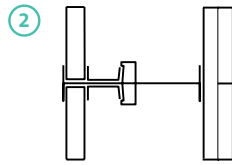
**(NB)** Gyproframe Extra Deep Flange Floor & Ceiling Channel or Gyproframe 'J' Channel should be used at the head. For the base Gyproframe Folded Edge Standard Floor & Ceiling Channel should be used for heights up to 4200mm, Gyproframe Deep Flange Floor & Ceiling Channel should be used for heights between 4200mm and 8000mm, Gyproframe Extra Deep Flange Floor & Ceiling Channel should be used for heights in excess of 8000mm.



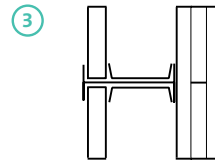
Table 2a — Solutions to satisfy the requirements of BS EN 1364-1: 1999



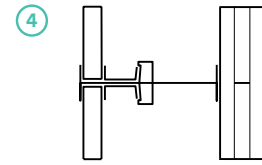
Gyprock 60, 70 or 92mm 'I' Stud framework with 20mm Glasroc F FIRECASE between studs, secured by Gyprock Retaining Channel. 25mm  
 Isover Acoustic Roll in cavity (optional).  
 Lining boards to non-shaft side, see table. Studs at 600mm centres.



Gyprock 146 TI 90 Tabbled 'I' Stud framework with 20mm Glasroc F FIRECASE between studs, secured by Gyprock Retaining Channel. 25mm  
 Isover Acoustic Roll in cavity (optional).  
 Lining boards to non-shaft side, see table. Studs at 600mm centres.



Gyprock 60, 70 or 92mm 'I' Stud framework with 20mm Glasroc F FIRECASE between studs, secured by Gyprock Retaining Channel. 25mm  
 Isover Acoustic Roll in cavity (optional).  
 Lining boards to non-shaft side, see table. Studs at 600mm centres.



Gyprock 146 TI 90 Tabbled 'I' Stud framework with 20mm Glasroc F FIRECASE between studs, secured by Gyprock Retaining Channel. 25mm  
 Isover Acoustic Roll in cavity (optional).  
 Lining boards to non-shaft side, see table. Studs at 600mm centres.

Detail	Partition thickness mm	Lining boards to non-shaft side		Max. partition height <sup>1</sup> mm	Stud size mm	Sound insulation $R_w$ dB <sup>2</sup>		Duty rating <sup>4</sup>	Approx. weight kg/m <sup>2</sup>	System reference
		Board type	Lining thickness mm			No insulation	Sealed structure plus 25mm Isover Acoustic Roll <sup>3</sup>			
<b>90 minutes fire resistance</b> (EN)										
1	92	Glasroc F FIRECASE	2 x 15	4500	60	41	44	Severe	46	G306003/023
1	102	Glasroc F FIRECASE	2 x 15	4500	70	41	44	Severe	46	G306003/023
1	124	Glasroc F FIRECASE	2 x 15	6000	92	43	45	Severe	47	G306006/025
2	178	Glasroc F FIRECASE	2 x 15	6000	146	47	49	Severe	49	G306009/028
<b>120 minutes fire resistance</b> (EN)										
3	107	Glasroc F FIRECASE	3 x 15	4500	60	42	44	Severe	59	G306030/035
3	117	Glasroc F FIRECASE	3 x 15	4500	70	42	44	Severe	59	G306030/035
3	139	Glasroc F FIRECASE	3 x 15	6000	92	44	45	Severe	60	G306031/036
4	193	Glasroc F FIRECASE	3 x 15	6000	146	48	49	Severe	62	G306032/033

▶ For further assistance in choosing the right solution for your project, try our System Selector; an online tool that enables quick and easy filtering by performance criteria. It provides system specific information downloads including BIM (Revit) objects. Go to [gyproc.ie](http://gyproc.ie)

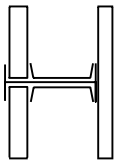
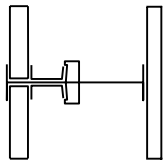
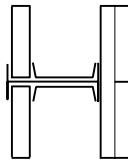
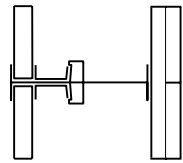
<sup>1</sup> The maximum heights quoted are limited by the fire state field of application or by limiting deflection of L/240 at 200 Pa, whichever is the more onerous.  
<sup>2</sup> The acoustic performance figures quoted include ShaftWall partitions with deflection heads.  
<sup>3</sup> 20mm Glasroc F FIRECASE and first layer of lining board are bedded onto Gyproc Sealant, as required for pressurised air shafts, in addition to normal sealing.  
<sup>4</sup> Estimated rating from non-shaft side only.

**(NB)** The fire resistance and sound insulation performances are for imperforate partitions, but incorporating deflection heads, with all joints taped and filled, or skimmed according to Gyproc's recommendations. The quoted performances are achieved only if Gyproc and Isover components are used throughout, and the Company's fixing recommendations are strictly observed. Any variation in the specifications should be checked with Gyproc.

**(NB)** Gyprock Extra Deep Flange Floor & Ceiling Channel or Gyprock 'J' Channel should be used at the head. For the base Gyprock Folded Edge Standard Floor & Ceiling Channel should be used for heights up to 4200mm. Gyprock Deep Flange Floor & Ceiling Channel should be used for heights between 4200mm and 8000mm, Gyprock Extra Deep Flange Floor & Ceiling Channel should be used for heights in excess of 8000mm.



**Table 2b — Solutions to satisfy requirements of BS 476: Part 22: 1987**

<p>①</p> 	<p>②</p> 	<p>③</p> 	<p>④</p> 
--	--	---	--

Detail	Partition thickness mm	Lining boards to non-shaft side		Max. partition height <sup>1</sup> mm	Stud size mm	Sound insulation $R_w$ dB <sup>2</sup>		Duty rating <sup>4</sup>	Approx. weight kg/m <sup>2</sup>	System reference
		Board type	Lining thickness mm			No insulation	Sealed structure plus 25mm Isover Acoustic Roll <sup>3</sup>			
<b>(60)/30 minutes fire resistance (BS) (exposure to fire from shaft side)</b>										
①	77	Glasroc F FIRECASE	1 x 15	4200	60	38	41	Heavy	32	G306001/010
①	87	Glasroc F FIRECASE	1 x 15	4200	70	38	41	Heavy	32	G306001/010
①	109	Glasroc F FIRECASE	1 x 15	6000	92	39	42	Heavy	33	G306004/011
②	163	Glasroc F FIRECASE	1 x 15	7700	146	42	45	Heavy	35	G306007/013
<b>(90)/60 minutes fire resistance (BS) (exposure to fire from shaft side)</b>										
①	92	Glasroc F FIRECASE	2 x 15	4500	60	41	44	Severe	46	G306003/023
①	102	Glasroc F FIRECASE	2 x 15	4500	70	41	44	Severe	46	G306003/023
①	124	Glasroc F FIRECASE	2 x 15	6400	92	43	45	Severe	47	G306006/025
②	178	Glasroc F FIRECASE	2 x 15	7900	146	47	49	Severe	49	G306009/028
<b>(120)/90 minutes fire resistance (BS) (exposure to fire from shaft side)</b>										
③	92	Glasroc F FIRECASE	2 x 15	4500	60	41	44	Severe	46	G306003/023
③	102	Glasroc F FIRECASE	2 x 15	4500	70	41	44	Severe	46	G306003/023
③	124	Glasroc F FIRECASE	2 x 15	6700	92	43	45	Severe	47	G306006/025
④	178	Glasroc F FIRECASE	2 x 15	7900	146	47	49	Severe	49	G306009/028

▶ For further assistance in choosing the right solution for your project, try our System Selector; an online tool that enables quick and easy filtering by performance criteria. It provides system specific information downloads including BIM (Revit) objects. Go to [gyproc.ie](http://gyproc.ie)

<sup>1</sup> Based on limiting deflection of L/240 at 200 Pa.

<sup>2</sup> The acoustic performance figures quoted include ShaftWall partitions with deflection heads.

<sup>3</sup> 20mm Glasroc F FIRECASE and first layer of lining board are bedded onto Gyproc Sealant, as required for pressurised air shafts, in addition to normal sealing.

<sup>4</sup> Estimated rating from non-shaft side only.

**(NB)** The fire resistance and sound insulation performances are for imperforate partitions, but incorporating deflection heads, with all joints taped and filled, or skimmed according to Gyproc's recommendations. The quoted performances are achieved only if Gyproc and Isover components are used throughout, and the Company's fixing recommendations are strictly observed. Any variation in the specifications should be checked with Gyproc.

**(NB)** Gypframe Extra Deep Flange Floor & Ceiling Channel or Gypframe 'J' Channel should be used at the head. For the base Gypframe Folded Edge Standard Floor & Ceiling Channel should be used for heights up to 4200mm, Gypframe Deep Flange Floor & Ceiling Channel should be used for heights between 4200mm and 8000mm, Gypframe Extra Deep Flange Floor & Ceiling Channel should be used for heights in excess of 8000mm.

## ShaftWall performance (continued)

## Vertical elements

Table 3 — Limiting heights at various air pressure and allowable deflections

Detail	System	Allowable deflection	Limiting height (mm) at stated air pressure (Pa)									System reference
			200	240	300	360	400	480	500	600	650	
①	ShaftWall	L/125	5000	4700	4400	4100	4000	3800	3700	3500	3400	A306001/010
		L/240	4200	4000	3700	3500	3300	3200	3100	2900	2800	
		L/360	3700	3500	3300	3100	2900	2800	2700	2600	2500	
②	ShaftWall	L/125	5000	4700	4400	4100	4000	3800	3700	3500	3400	Based on A306001/010
		L/240	4200	4000	3700	3500	3300	3200	3100	2900	2800	
		L/360	3700	3500	3300	3100	2900	2800	2700	2600	2500	
③	ShaftWall	L/125	7500	7100	6600	6200	6000	5700	5500	5200	5100	A306004/011
		L/240	6000	5700	5300	5000	4800	4600	4400	4200	4100	
		L/360	5200	4900	4600	4300	4200	4000	3900	3600	3500	
④	ShaftWall	L/125	5200	4900	4600	4300	4200	4000	3800	3600	3500	A306002/012
		L/240	4400	4100	3800	3600	3500	3300	3200	3000	2900	
		L/360	3800	3600	3300	3100	3000	2900	2800	2600	2500	
⑤	ShaftWall	L/125	5200	4900	4600	4300	4200	4000	3800	3600	3500	Based on A306002/012
		L/240	4400	4100	3800	3600	3500	3300	3200	3000	2900	
		L/360	3800	3600	3300	3100	3000	2900	2800	2600	2500	
⑥	ShaftWall	L/125	7900	7400	6900	6500	6300	5900	5800	5500	5300	A306005/014
		L/240	6400	6000	5600	5200	5000	4800	4700	4400	4300	
		L/360	5600	5200	4900	4600	4400	4200	4100	3900	3800	
⑦	ShaftWall	L/125	9800	9200	8600	8100	7800	7300	7200	6800	6600	A306008/020
		L/240	7900	7400	6900	6500	6200	6000	5800	5500	5300	
		L/360	6900	6500	6000	5600	5500	5200	5100	4800	4600	

► For further assistance in choosing the right solution for your project, try our System Selector; an online tool that enables quick and easy filtering by performance criteria. It provides system specific information downloads including BIM (Revit) objects. Go to [gyproc.ie](http://gyproc.ie)

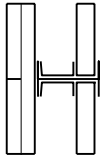
<sup>1</sup> Gyproc FireLine can be replaced with Glasroc F FIRECASE.

## ShaftWall performance (continued)

### Vertical elements

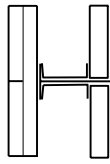
Table 3 — Limiting heights at various air pressure and allowable deflections (continued)

8



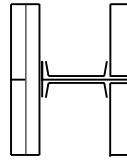
Gypframe 60 I 70 'I' Stud framework with two layers of 15mm Gyproc FireLine<sup>1</sup>.

9



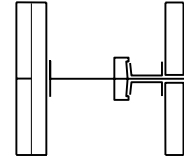
Gypframe 70 I 70 'I' Stud framework with two layers of 15mm Gyproc FireLine<sup>1</sup>.

10



Gypframe 92 I 90 'I' Stud framework with two layers of 15mm Gyproc FireLine<sup>1</sup>.

11



Gypframe 146 TI 90 Tabbed 'I' Stud framework with two layers of 15mm Gyproc FireLine<sup>1</sup>.

Detail	System	Allowable deflection	Limiting height (mm) at stated air pressure (Pa)									System reference
			200	240	300	360	400	480	500	600	650	
8	ShaftWall	L/125	5200	4900	4600	4300	4100	4000	3800	3600	3500	A306003/023
		L/240	4500	4200	3900	3700	3500	3400	3300	3100	3000	
		L/360	3900	3700	3400	3200	3100	3000	2900	2700	2600	
9	ShaftWall	L/125	5200	4900	4600	4300	4100	4000	3800	3600	3500	Based on A306003/023
		L/240	4500	4200	3900	3700	3500	3400	3300	3100	3000	
		L/360	3900	3700	3400	3200	3100	3000	2900	2700	2600	
10	ShaftWall	L/125	8400	7900	7300	6900	6600	6300	6200	5800	5600	A306006/025
		L/240	6700	6300	5900	5500	5300	5100	5000	4700	4500	
		L/360	5600	5300	4900	4600	4500	4200	4100	3900	3800	
11	ShaftWall	L/125	9900	9300	8600	8100	7800	7400	7200	6800	6600	A306009/028
		L/240	7900	7400	6900	6500	6300	6000	5800	5500	5300	
		L/360	6900	6500	6000	5700	5500	5200	5100	4800	4700	

► For further assistance in choosing the right solution for your project, try our System Selector; an online tool that enables quick and easy filtering by performance criteria. It provides system specific information downloads including BIM (Revit) objects. Go to [gyproc.ie](http://gyproc.ie)

These tables give the limiting heights for ShaftWall systems when subjected to air pressures ranging from 200 Pa through to 650 Pa and at three allowable deflection levels - L/125, L/240, L/360. Partition heights are normally quoted for air pressures of 200 Pa at an allowable deflection of L/240.

When the fire performance of ShaftWall is specified in terms of EN 1364-1: 1999, then the maximum height cannot exceed that given in the relevant table in this book, irrespective of air pressure or allowable deflection.

<sup>1</sup> Gyproc FireLine can be replaced with Glasroc F FIRECASE.

**NB** Gypframe Extra Deep Flange Floor & Ceiling Channel or Gypframe 'J' Channel should be used at the head. For the base Gypframe Folded Edge Standard Floor & Ceiling Channel should be used for heights up to 4200mm, Gypframe Deep Flange Floor & Ceiling Channel should be used for heights between 4200mm and 8000mm, Gypframe Extra Deep Flange Floor & Ceiling Channel should be used for heights in excess of 8000mm.

## ShaftWall performance (continued)

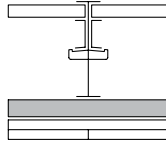
## Horizontal elements

For details of when to specify fire resistance using EN  
 ▶ Refer to C02. S01. P18



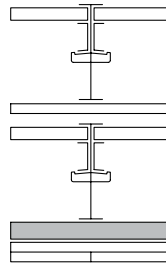
Table 4a – Solutions to satisfy the requirements of BS EN 1364-2: 1999

①



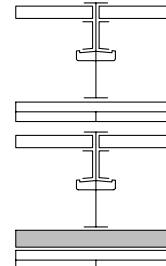
Gypframe 60, 70 or 92mm 'I' Stud or Gypframe 146 TI 90 Tabbed 'I' Stud frames at 600mm centres with Gyproc CoreBoard between studs, secured by Gyproc Retaining Channel. 25mm Isover Acoustic Roll in cavity (optional). Gypframe MF5 Ceiling Sections fixed to ceiling side at 450mm centres. Lining boards to ceiling side, see table.

②



Two Gypframe 146 TI 90 Tabbed 'I' Stud frames at 600mm centres with Gyproc CoreBoard between studs, secured by Gyproc Retaining Channel. 25mm Isover Acoustic Roll in cavity (optional). On the lower framework only, Gypframe MF5 Ceiling Sections fixed to ceiling side at 450mm centres. Lining boards to ceiling side, see table.

③



Two Gypframe 146 TI 90 Tabbed 'I' Stud frames at 600mm centres with Gyproc CoreBoard between studs, secured by Gyproc Retaining Channel. 25mm Isover Acoustic Roll in cavity (optional). On the lower framework only, Gypframe MF5 Ceiling Sections fixed to ceiling side at 450mm centres. Lining boards to ceiling side, see table.

Detail	Thickness mm	Lining boards to non-shaft side		Max. span <sup>1</sup> mm	Stud size mm	Sound insulation $R_w$ dB		Approx. weight kg/m <sup>2</sup>	System reference
		Board type	Lining thickness mm			No insulation	Sealed structure plus 25mm Isover Acoustic Roll		
<b>60 minutes fire resistance</b> (EN)									
①	120	Gyproc FireLine	2 x 15	2500	60	42	45	39	C106053
①	130	Gyproc FireLine	2 x 15	2800	70	42	45	39	C106053
①	152	Gyproc FireLine	2 x 15	3000	92	44	46	39	C106054
①	206	Gyproc FireLine	2 x 15	4000	146	48	50	39	C106055
<b>90 minutes fire resistance</b> (EN)									
②	397	{ Gyproc FireLine upper frame Gyproc FireLine lower frame	{ 1 x 15 2 x 15 }	4400	146	48	50	77	C106057
<b>120 minutes fire resistance</b> (EN)									
③	422	{ Gyproc FireLine upper frame Gyproc FireLine lower frame	{ 2 x 15 2 x 15 }	4000	146	48	50	88	C106056

▶ For further assistance in choosing the right solution for your project, try our System Selector; an online tool that enables quick and easy filtering by performance criteria. It provides system specific information downloads including BIM (Revit) objects. Go to [gyproc.ie](http://gyproc.ie)

<sup>1</sup> Based on fire state field of application, or by a limiting deflection of L/400, whichever is greater.

**(NB)** The fire resistance and sound insulation performances are for imperforate ceilings incorporating boards, with all joints taped and filled, or skimmed according to Gyproc's recommendations. The quoted performances are achieved only if Gyproc and Isover components are used throughout, and the Company's fixing recommendations are strictly observed. Any variation in the specifications should be checked with Gyproc.

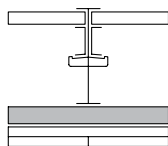
**(NB)** ShaftWall used horizontally should not be used for materials storage or access for personnel, or to provide support to services.

**(NB)** Gypframe Extra Deep Flange Floor & Ceiling Channel or Gypframe 'J' Channel should be used at perimeter.



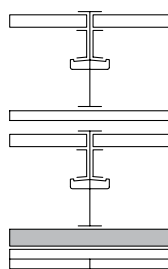
Table 4b – Solutions to satisfy requirements of BS 476: Part 22: 1987

①



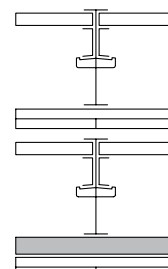
Gypframe 60, 70 or 92mm 'I' Stud or Gypframe 146 TI 90 Tabbed 'I' Stud frames at 600mm centres with Gyproc CoreBoard between studs, secured by Gyproc Retaining Channel. 25mm Isover Acoustic Roll in cavity (optional). Gypframe MF5 Ceiling Sections fixed to ceiling side at 450mm centres. Lining boards to ceiling side, see table.

②



Two Gypframe 146 TI 90 Tabbed 'I' Stud frames at 600mm centres with Gyproc CoreBoard between studs, secured by Gyproc Retaining Channel. 25mm Isover Acoustic Roll in cavity (optional). On the lower framework only, Gypframe MF5 Ceiling Sections fixed to ceiling side at 450mm centres. Lining boards to ceiling side, see table.

③



Two Gypframe 146 TI 90 Tabbed 'I' Stud frames at 600mm centres with Gyproc CoreBoard between studs, secured by Gyproc Retaining Channel. 25mm Isover Acoustic Roll in cavity (optional). On the lower framework only, Gypframe MF5 Ceiling Sections fixed to ceiling side at 450mm centres. Lining boards to ceiling side, see table.

Detail	Thickness mm	Lining boards to non-shaft side		Max. span <sup>1</sup> mm	Stud size mm	Sound insulation $R_w$ dB		Approx. weight kg/m <sup>2</sup>	System reference
		Board type	Lining thickness mm			No insulation	Sealed structure plus 25mm Isover Acoustic Roll		
<b>60 minutes fire resistance</b>									
①	120	Gyproc FireLine	2 x 15	2500	60	42	45	39	C106053
①	130	Gyproc FireLine	2 x 15	2800	70	42	45	39	C106053
①	152	Gyproc FireLine	2 x 15	3700	92	44	46	39	C106054
①	206	Gyproc FireLine	2 x 15	5100	146	48	50	39	C106055
<b>90 minutes fire resistance</b>									
②	397	{ Gyproc FireLine upper frame Gyproc FireLine lower frame	{ 1 x 15 2 x 15 }	5100	146	48	50	77	C106057
<b>120 minutes fire resistance</b>									
③	422	{ Gyproc FireLine upper frame Gyproc FireLine lower frame	{ 2 x 15 2 x 15 }	5100	146	48	50	88	C106056

▶ For further assistance in choosing the right solution for your project, try our System Selector; an online tool that enables quick and easy filtering by performance criteria. It provides system specific information downloads including BIM (Revit) objects. Go to [gyproc.ie](http://gyproc.ie)

<sup>1</sup>Based on a limiting deflection of L/400.

**NB** The fire resistance and sound insulation performances are for imperforate ceilings incorporating boards, with all joints taped and filled, or skimmed according to Gyproc's recommendations. The quoted performances are achieved only if Gyproc and Isover components are used throughout, and the Company's fixing recommendations are strictly observed. Any variation in the specifications should be checked with Gyproc.

**NB** ShaftWall used horizontally should not be used for materials storage or access for personnel, or to provide support to services.

**NB** Gypframe Extra Deep Flange Floor & Ceiling Channel or Gypframe 'J' Channel should be used at perimeter.

## Building design

ShaftWall comprises Gypframe 'I' Studs and Gypframe Starter Channels within Gypframe Floor & Ceiling Channels.

The shaft-side boards are retained between the Gypframe Floor & Ceiling Channels and adjacent studs using Gypframe Retaining Channels; which enables construction from the side only.

## Planning – key factors

The position of services should be pre-determined and their installation planned into the frame erection stage. Timber sole plates should be considered, if appropriate, where the floor is uneven.

► Refer to C02. S01. P41 – Service installations.



### Important information

When exposed to fire from the corridor side in accordance with *BS 476: Part 22*, an insulation failure will occur. If relaxation from Building Control is not given and a full fire rating (insulation and integrity) is required in both directions, the following options are available:

- Use equivalent *EN 1364-1* specification, e.g. if 60 minutes *BS 476: Part 22* performance is required, use a 60 minutes *EN 1364-1* specification
- Specify the next level of fire performance from BS table, e.g. if 60 minutes *BS 476: Part 22* performance is required, use a 90 minute *BS 476: Part 22* specification<sup>1</sup>

It is important that a good standard of control is exercised on site to ensure that the adoption of drylining techniques at such an early stage of construction is fully integrated into the site planning programme. If the building envelope is left unsealed while ShaftWall is under construction, Gyproc FireLine MR or Glasroc F FIRECASE should be used for the lining. All penetrations will need to be adequately fire-stopped.



### Important information

For ShaftWall systems utilising Gypframe 60 I 70 'I' Studs, Gypframe 62 JC 70 'J' Channel with its asymmetrical legs is needed at the head to facilitate the installation of the Gyproc CoreBoard. The shorter leg is installed facing the non-shaft side. For ShaftWall systems that use wider Gypframe 'I' studs, the appropriate Gypframe Extra Deep Flange Floor and Ceiling Channel should be used.

## Fixing the floor channel

The floor channel must have continuous support along its length to maintain specified performance levels. If continuous support is not provided by the structure, e.g. Z-sections running transverse to a steel beam, the designer should detail the installation of a rigid non-combustible material between the Z-sections. Z-sections need to be protected and remain in-situ in the event of a fire, taking into account any loads they are supporting.

In situations where the floor channel is fixed to diagonal structural steel, the studs should be accurately scribed to the rake of the channel to maintain the full bearing surface.

## Fixing to metal decking

Where ShaftWall is to be located transverse to the profiles of the decking, all slots or perforations above the head channel should be sealed using a proprietary fire barrier or fire spray. Fire-stopping material can be applied prior to the head channel being positioned, providing that any surplus is removed flush with the steel decking.

## Fixing to structural steel encasements

Where ShaftWall abuts a column or beam encasement, the framing will generally require fixing to the structural steelwork.

Where ShaftWall abuts the web of the steelwork a Z-section can be located to provide a fixing point level with the flanges of the steelwork. With FireCase encasements, where fire resistance up to 60 minutes and a Light or Medium Duty Rating to *BS 5234* is required, it is possible to fix directly to the board cladding subject to fire resistance and loading criteria.

► Refer to C03. S02. P84 – FireCase construction details.



### Handy hint

Where the floor channel is not fully supported, e.g. at the edge of a floor slab, Gypframe Extra Deep Flange Floor & Ceiling Channel or Gypframe 'J' Channel must be used with a continuous 19mm Gyproc CoreBoard fire stop inserted into the base of the channel. The maximum allowable overhang is 25% of the floor channel width.

## Limiting heights at different air pressures

The maximum heights quoted in the performance tables for vertical elements are based on a limiting deflection of L/240 at 200 Pa, or by the fire state field of application. In practice, deflection from L/125 to L/360 may be allowed and pressure conditions between 200 Pa and 650 Pa may be encountered. These variations will affect the maximum wall height. Refer to table 3.

<sup>1</sup> Where 120 mins is required to *BS 476: Part 22*, replace the inner layer of 15mm Gyproc FireLine (corridor side) with 19mm Gyproc CoreBoard, fixed horizontally.

## ShaftWall design (continued)

### Connection to the structure

Structural steelwork and its associated connections often result in complex junctions around shafts. If **ShaftWall** is built on the same line as the beamwork framing the shaft, problems may arise in trying to seal the wall up to the steelwork. It is recommended that, wherever possible, the wall should be located to one side of the beams, and fixed from structural floor to structural soffit.

### Partition to structural steelwork junctions

When designing the layout of rooms requiring separation by sound insulating walls abutting structural steelwork, consideration should be given to the potential loss of sound insulation performance through the steelwork.

► Refer to C02. S01. P21 – Building acoustics.

### Door openings

In the case of both normal access doors and lift doors, the door and frame assembly must have been shown by a fire resistance test to achieve the required standard of performance in this form of construction.

Lift doors must be substantiated in conjunction with **ShaftWall** complete with their framing members and transom panels. To achieve a satisfactory level of compatibility, a suitable starter channel should be mechanically fixed to the door frame at 300mm centres.

► Refer to construction details 23-25 within this section.

### Pressurised airshafts and service ducts

The use of pressure conditions in various types of shaft / duct requires that the boards should be sealed into the framing members using Gyproc Sealant in addition to the normal sealing of the framing to adjoining structures. It is essential that these areas are identified at a very early stage of the contract, and that other trades are instructed to recognise the need for the application of sealant and its replacement if subsequently damaged or removed. In order that the integrity of the pressurised system can be maintained, Gyproc Sealant should be specified for all board-to-metal applications, and the sealing of Gyproc CoreBoard (or Glasroc F FIRECASE) to the framing.

► Refer to construction details 17-20 within this section.

### Control joints

Control joints may need to be considered in conditions where excessive movement is likely to occur, or to coincide with constructional expansion joints. In order that the deflection criteria can be maintained throughout the building, it is necessary to introduce horizontal movement joints in the lining where this would normally be required to extend through the height of the building, e.g. stairwells.

The horizontal movement joint can be accommodated adjacent to the floor slab.

► Refer to construction detail 28 within this section.

### Deflection heads

Deflection heads, by definition, must be able to move and, therefore, achieving an airtight seal is difficult. Inevitably, this will have a detrimental effect on the acoustic performance of any wall that incorporates deflection at the head. In most cases, a suspended ceiling will assist in minimising loss of performance.

► Refer to construction details 11-17 for standard head details.

Gyproc FireStrip must be applied as a continuous seal where indicated to maintain fire performance. Also, board fixings must not be inserted above the uppermost line depicted by the red arrow in each drawing. Designs incorporating Gypframe Retaining Clips are not suitable for live loads. Where greater deflection needs to be accommodated, contact the Gyproc Technical Department for further guidance.

### Deflection criteria

Partitions built to a maximum height based on L/125 at 200 Pa will exhibit greater deflection compared to partitions built to a maximum height based on L/240 at 200 Pa. Partitions with deflection characteristics outside the standard L/240 criteria will exhibit more flex during installation and in general use, and therefore we recommend you verify the acceptability of the deflections with the relevant interested parties before specifying / installing partitions based on L/125 criteria.

### Services

#### Penetrations

Penetrations of fire-resistant constructions for services should be minimised, however if essential, careful consideration should be given to ensure that the integrity of the element is not impaired, and that the services themselves do not act as the mechanism of fire spread.

► Refer to C02. S01. P41 – Service installations.

#### Independent support

When designing for the installation of services such as fire dampers and associated ductwork through **ShaftWall**, consideration should be given to the size and weight of the damper – this will determine whether it can be supported directly from the partition or needs to be independently supported from the structure.

► Refer to C04. S01. P122 – Partitions introduction, construction details 29-31.

#### Openings bridging studs

Openings should be constructed using channels for the trimming members. The web of the channel should be rebated to allow the flanges to oversail the stud. The flanges are secured with two fixings. Channels are cut and inserted to maintain the 25mm gap surround and fixed to the trimming channels.

► Refer to construction detail 21 within this section.



### Important information

The quoted sound insulation performances of **ShaftWall**, detailed in the preceding performance tables, incorporate a deflection head as part of the tested construction. Therefore, this effectively downgrades the sound insulation performance of the system. To minimise the loss, install Gypframe GA4 Steel Angle at the head, which will improve the performance by approximately 2-3dB, refer to C02. S01. P21 – Building acoustics. The installation of a Gypframe RB1 Resilient Bar may further improve performance, contact the Gyproc Technical Department for further information.

#### Openings between studs

The opening is constructed using channels for the trimming members. The web should be rebated and the flanges allowed to oversail the studs. The stud is secured with two fixings. Channels are cut and inserted with the webs folded to provide fixings. A plasterboard packer is inserted adjacent to the stud.

► Refer to construction detail 22 within this section.

#### Electrical services

The installation of electrical services should be carried out in accordance with BS 7671. The positions for light switches and other electrical outlets should be pre-determined in order that provision can be made for support, and also for the fire integrity of the system.

Gypframe 99 FC 50 Fixing Channel should be cut to bridge adjoining studs, with the edges flattened to permit fixing. The fixing channel should be backed with stone mineral wool. Gyproc FireLine (or Glasroc FIRECASE) linings should be cut to allow a close fitting entry of the switch box which can be secured to the fixing channel.

► Refer to construction detail 7 within this section.

#### Access for maintenance

For access doors, openings should be framed to avoid impairing the structural or fire-resistant properties of **ShaftWall**. To provide an opening ready to receive a door set, the jambs to storey height should be capped with Gypframe 'J' Channel incorporating a plasterboard packer. A pre-formed spandrel panel assembled between starter channels should be inserted between jambs and engaged into the head channel, retaining the 15mm gap for deflection at the head.

► Refer to construction detail 23 within this section.

Support is provided by a Gypframe 'J' Channel transom. The door frame is secured to both Gypframe 'I' Stud and Gypframe 'J' Channel jambs and also to the transom member.

► Refer to construction detail 25 within this section.

A range of Gyproc Profilex Access Panels providing fire integrity is available. Please contact the Gyproc Technical Department for further information:

ROI: 1800 744480

NI: 0845 3990159

Email: tech.ie@saint-gobain.com

#### Board finishing

► Refer to C08. S01. P483 – Finishes.

#### Tiling

Tiles can be applied to the surface of lightweight partition systems.

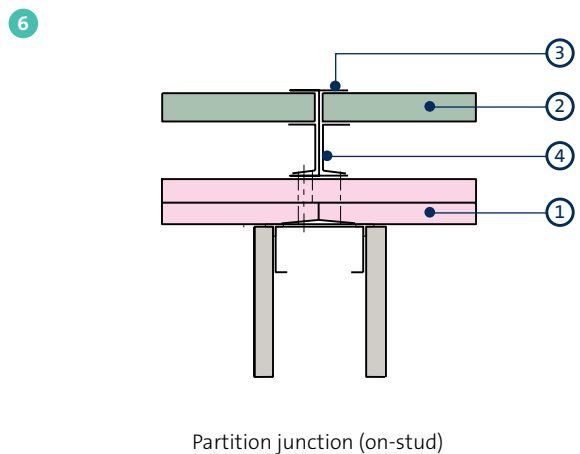
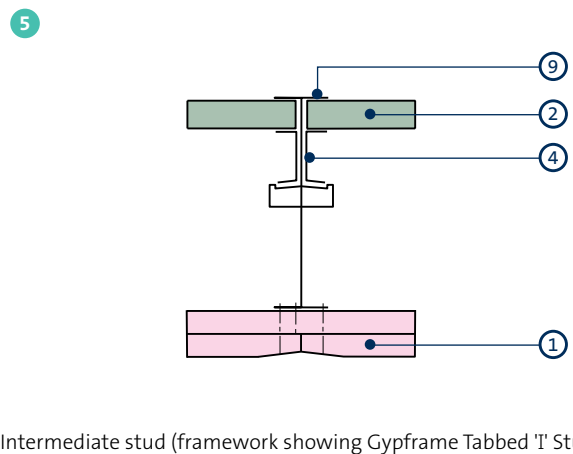
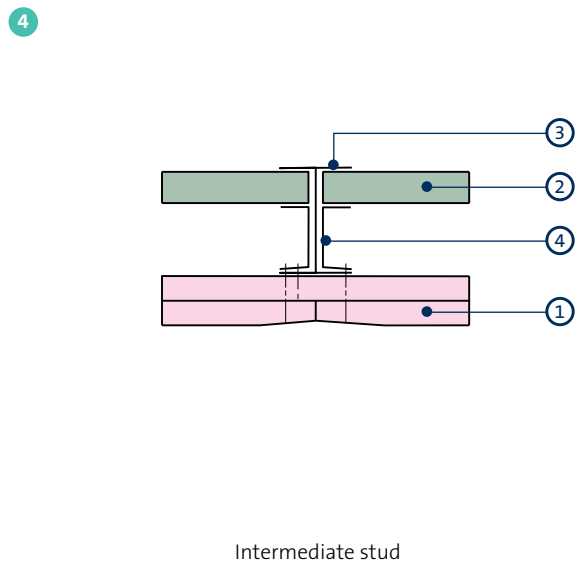
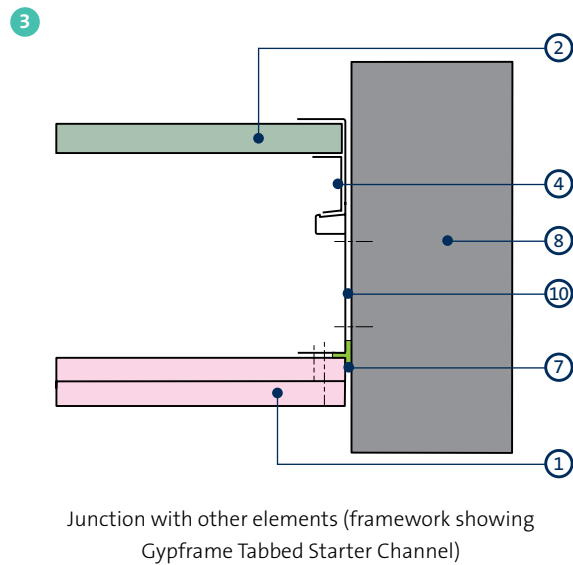
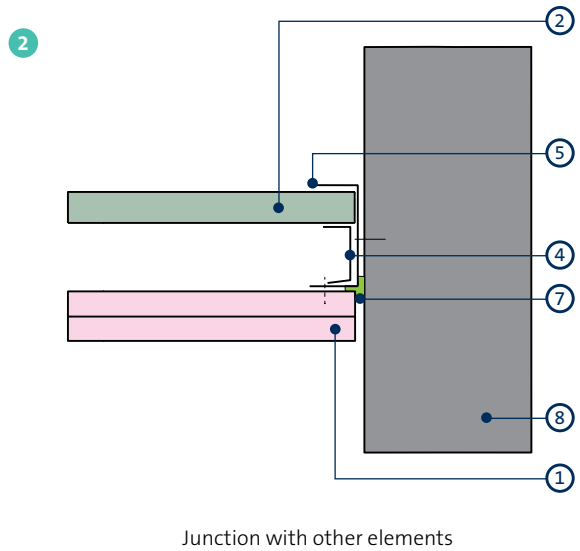
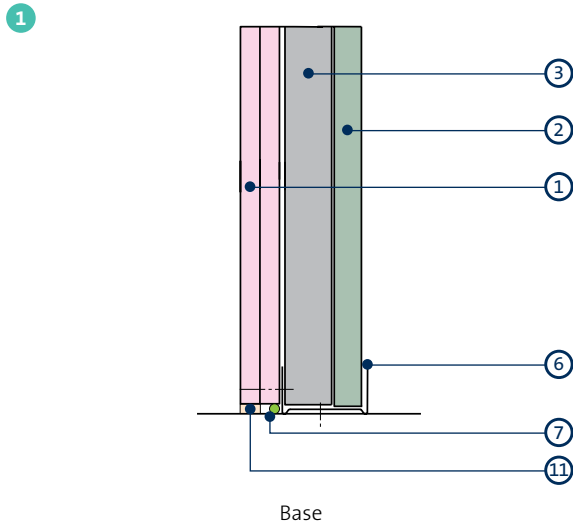
► Refer to C08. S04. P498 – Tiling.

#### Horizontal ShaftWall

**ShaftWall** can be specified for horizontal applications as a free-spanning membrane with no support from the soffit. The membrane can be constructed entirely from below and can achieve spans up to 5100mm and fire resistance up to 120 minutes. A typical application is for fire escape corridors. Services should be independently supported from the building structure.

Supporting partitions should be of at least the same fire resistance period as the horizontal **ShaftWall**.

# ShaftWall construction details



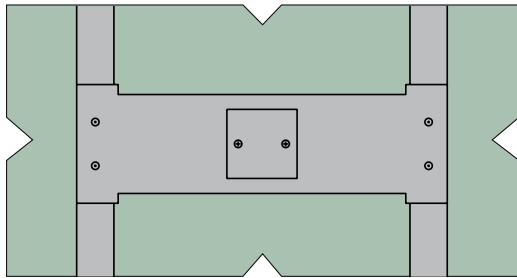
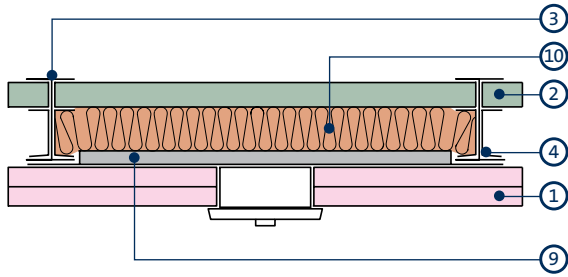
- 1 Gyproc FireLine<sup>1</sup>
- 2 Gyproc CoreBoard<sup>2</sup>
- 3 Gypframe 'T' Stud
- 4 Gypframe Retaining Channel
- 5 Gypframe Starter Channel
- 6 Gypframe Folded Edge Standard Floor & Ceiling Channel

- 7 Gyproc Sealant
- 8 Structure
- 9 Gypframe Tabbed 'T' Stud
- 10 Gypframe Tabbed Starter Channel
- 11 Bulk fill with Gyproc jointing materials (where gap exceeds 5mm)

<sup>1</sup> Replace with 15mm Glasroc F FIRECASE for systems with non-combustible linings.  
<sup>2</sup> Replace with 20mm Glasroc F FIRECASE for systems with non-combustible linings.

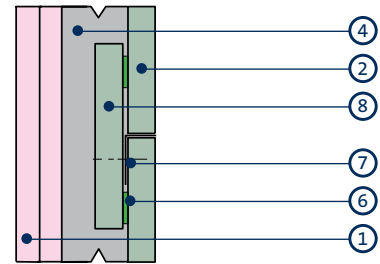
## ShaftWall construction details (continued)

7



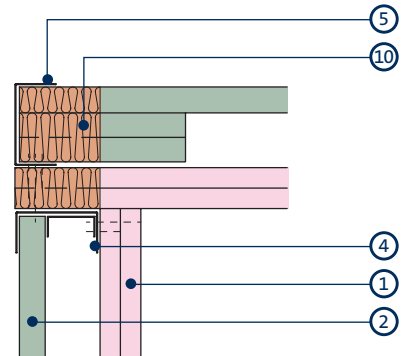
Socket box

8



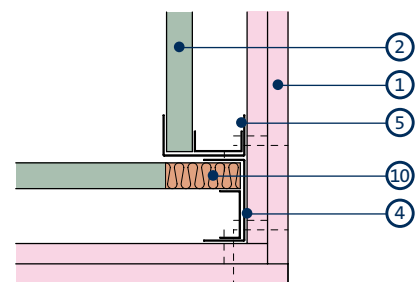
Horizontal Gyproc CoreBoard joints

9



Internal corner

10



External corner

- 1 Gyproc FireLine<sup>1</sup>
- 2 Gyproc CoreBoard<sup>2</sup>
- 3 Gypframe T Stud
- 4 Gypframe Retaining Channel
- 5 Gypframe Starter Channel

- 6 Gyproc Sealant
- 7 Gypframe GA3 Steel Angle
- 8 Gyproc CoreBoard strip (cut on site)<sup>2</sup>
- 9 Gypframe 99 FC 50 Fixing Channel
- 10 Stone mineral wool (100kg/m<sup>3</sup> - by others)

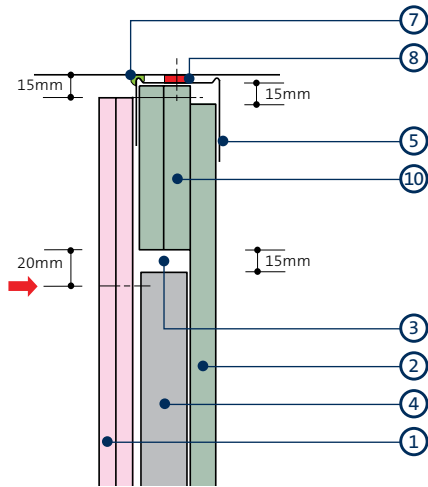
<sup>1</sup> Replace with 15mm Glasroc F FIRECASE for systems with non-combustible linings.

<sup>2</sup> Replace with 20mm Glasroc F FIRECASE for systems with non-combustible linings.

## ShaftWall construction details (continued)

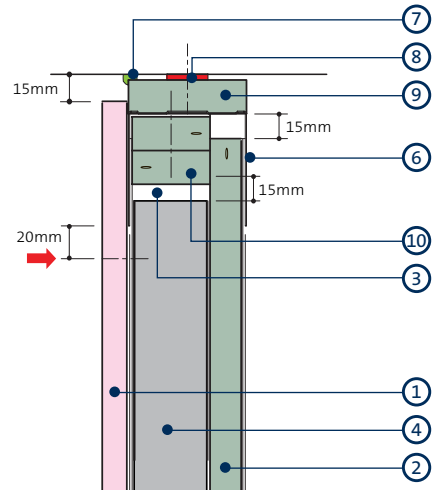
### Head details incorporating 15mm downward deflection

11



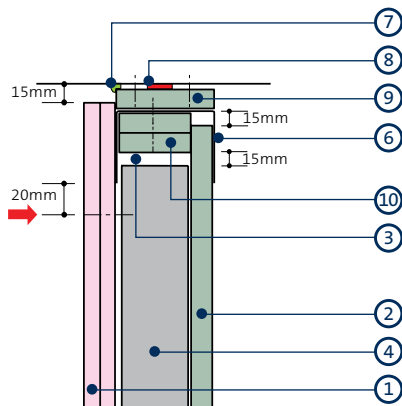
60mm framework (live loads)<sup>3</sup>  
- BS 476 Part 22: 1987

12



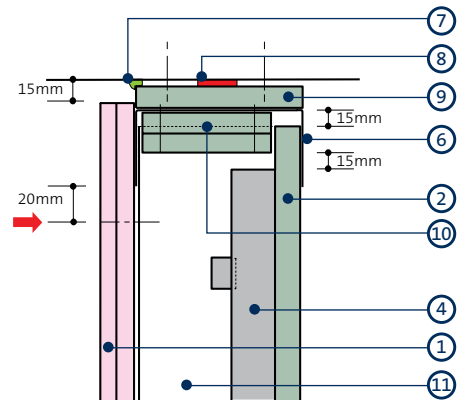
70mm framework (live loads)  
- BS 476 Part 22: 1987

13



92mm framework (live loads)  
- BS 476 Part 22: 1987

14



146mm framework (live loads)  
- BS 476 Part 22: 1987

- 1 Gyproc FireLine<sup>1</sup>
- 2 Gyproc CoreBoard<sup>2</sup>
- 3 Gypframe 'I' Stud
- 4 Gypframe Retaining Channel
- 5 Gypframe 'J' Channel
- 6 Gypframe Extra Deep Flange Floor & Ceiling Channel

- 7 Gyproc Sealant
- 8 Gyproc FireStrip
- 9 Gyproc CoreBoard<sup>2</sup>
- 10 Gyproc CoreBoard fire-stop<sup>2</sup>
- 11 Gypframe Tabbed 'I' Stud

<sup>1</sup> Replace with 15mm Glasroc F FIRECASE for systems with non-combustible linings.

<sup>2</sup> Replace with 20mm Glasroc F FIRECASE for systems with non-combustible linings.

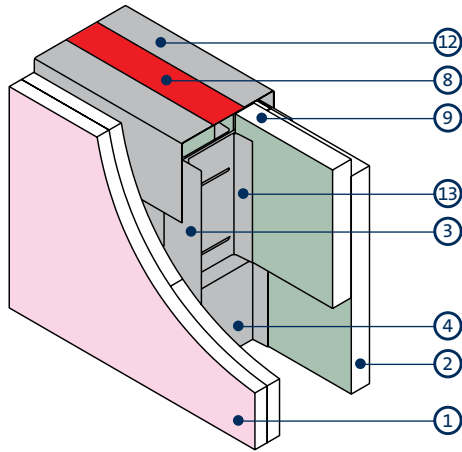
<sup>3</sup> Vertical fire-stops are not recommended for non-combustible linings, use horizontal fire-stops similar to detail 12.

**NB** No fixings should be made through the boards into the flanges of the head channel. The arrow (➡) denotes the position of the uppermost board fixing.

## ShaftWall construction details (continued)

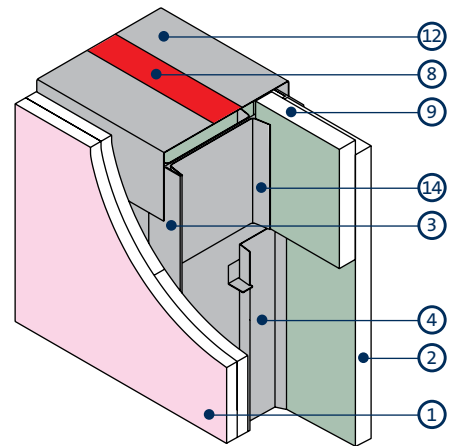
### Head details with Retaining Clips

15



Head incorporating Gypframe G108 Retaining Clip (92mm)  
- BS 476 Part 22: 1987

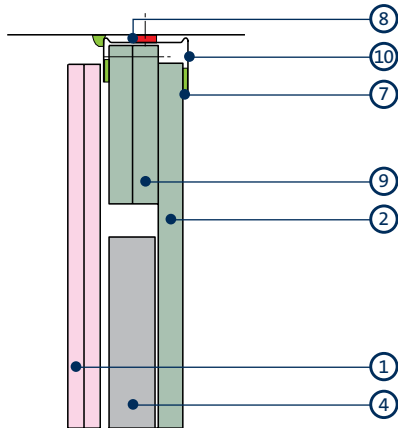
16



Head incorporating Gypframe G109 Retaining Clip (146mm)  
- BS 476 Part 22: 1987

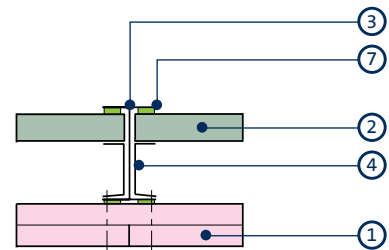
### Sealing pressurised air shafts and service ducts

17



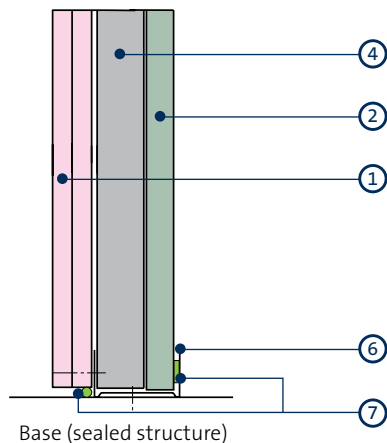
Head (sealed structure). Example shows 60mm stud<sup>3</sup>  
- BS 476 Part 22: 1987

18



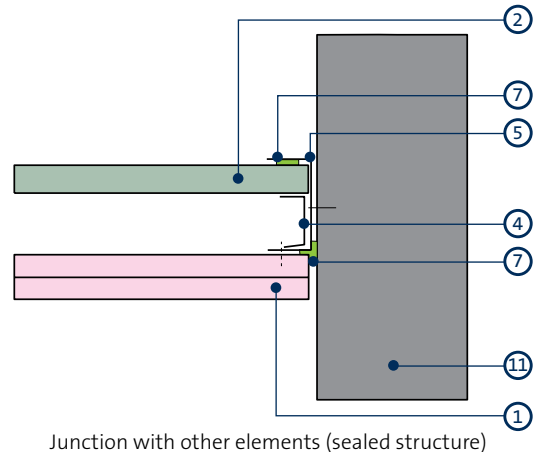
Intermediate stud (sealed structure)

19



Base (sealed structure)

20



Junction with other elements (sealed structure)

- 1 Gyproc FireLine<sup>1</sup>
- 2 Gyproc CoreBoard<sup>2</sup>
- 3 Gypframe 'I' Stud
- 4 Gypframe Retaining Channel
- 5 Gypframe Starter Channel
- 6 Gypframe Folded Edge Standard Floor & Ceiling Channel
- 7 Gyproc Sealant

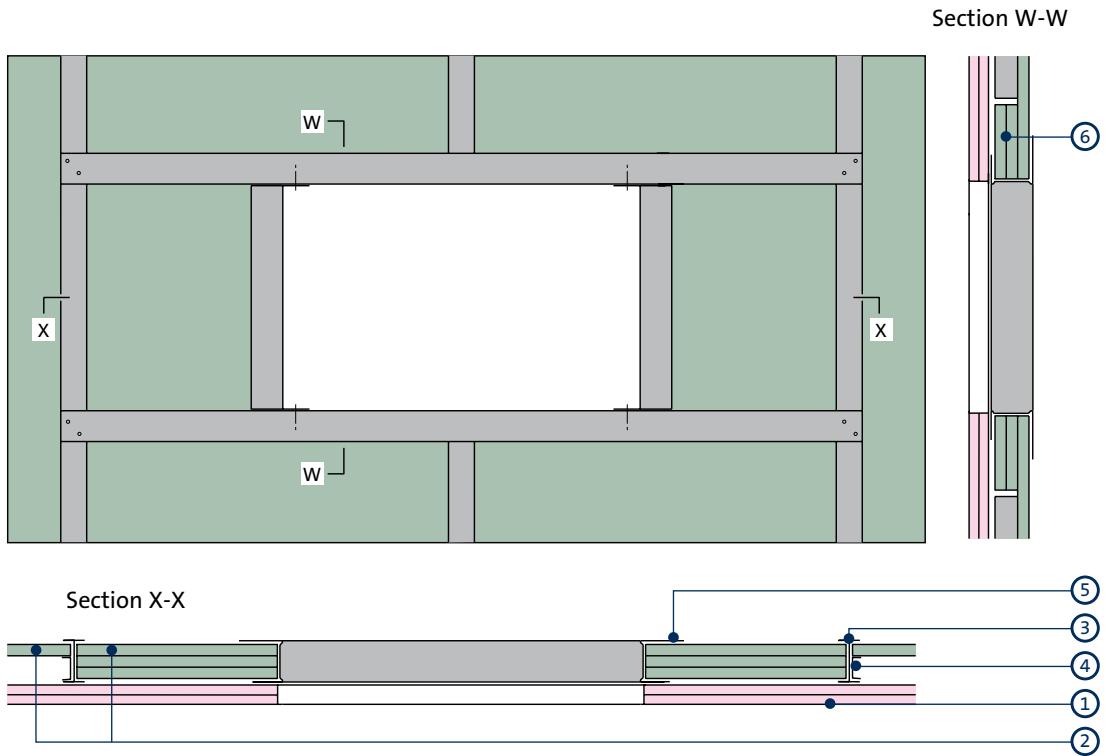
- 8 Gyproc FireStrip
- 9 Gyproc CoreBoard fire-stop (cut on site)<sup>2</sup>
- 10 Gypframe 'I' Channel
- 11 Structure
- 12 Gypframe Extra Deep Flange Floor & Ceiling Channel
- 13 Gypframe G108 Retaining Clip
- 14 Gypframe G109 Retaining Clip

<sup>1</sup> Replace with 15mm Glasroc F FIRECASE for systems with non-combustible linings.

<sup>2</sup> Replace with 20mm Glasroc F FIRECASE for systems with non-combustible linings.

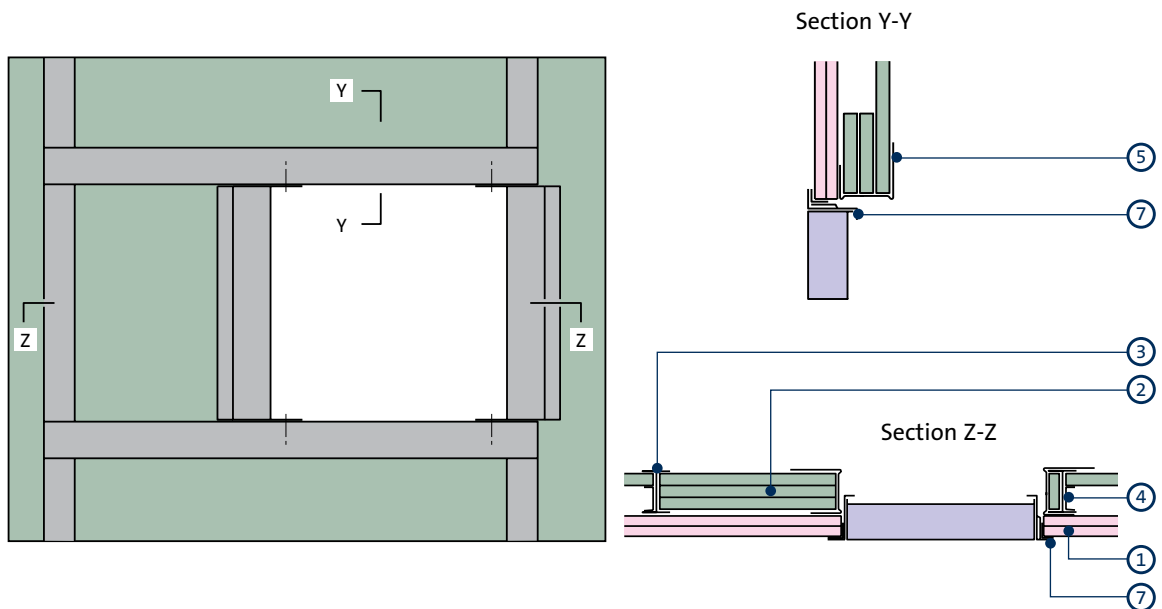
<sup>3</sup> Use alternative deflection head detail for systems with non-combustible linings.

21



Opening bridging studs. Example shows 60mm stud

22



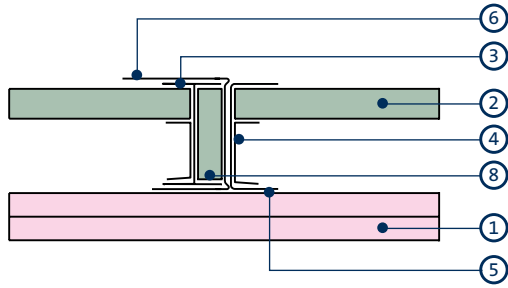
Opening between studs. Example shows 60mm stud

- 1 Gyproc FireLine
- 2 Gyproc CoreBoard
- 3 Gypframe 'T' Studs
- 4 Gypframe Retaining Channel

- 5 Gypframe 'J' Channel
- 6 Gyproc CoreBoard fire-stops (cut on site)
- 7 Access panel frame (by others)

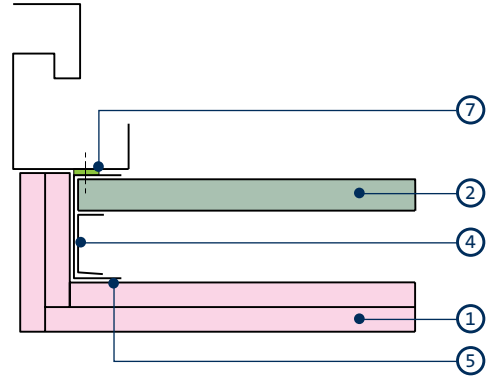
## ShaftWall construction details (continued)

23



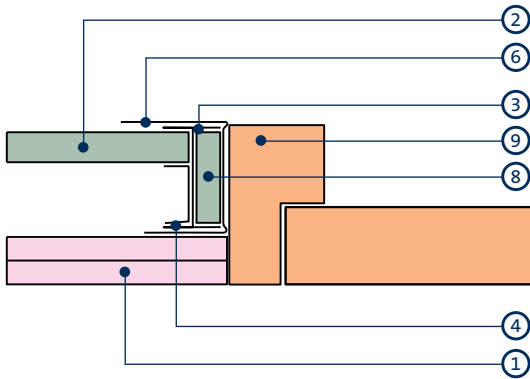
Access door - spandrel panel

24



Lift door (Gypframe Starter Channel mechanically fixed to frame)

25



Access door jamb

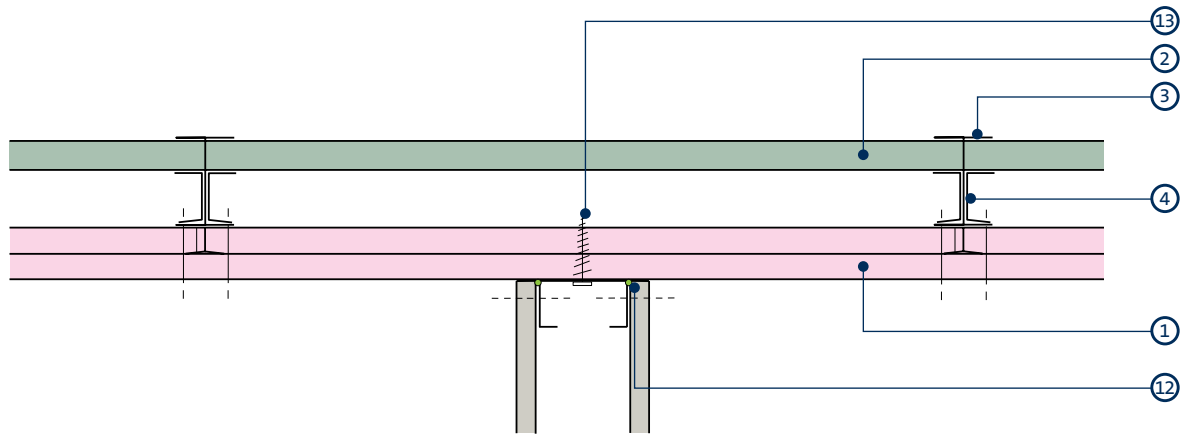
- 1 Gyproc FireLine<sup>1</sup>
- 2 Gyproc CoreBoard<sup>2</sup>
- 3 Gypframe 'T' Stud
- 4 Gypframe Retaining Channel
- 5 Gypframe Starter Channel

- 6 Gypframe 'J' Channel
- 7 Gyproc Sealant
- 8 Gyproc CoreBoard packer (cut on site)<sup>2</sup>
- 9 Door frame

<sup>1</sup> Replace with 15mm Glasroc F FIRECASE for systems with non-combustible linings.

<sup>2</sup> Replace with 20mm Glasroc F FIRECASE for systems with non-combustible linings.

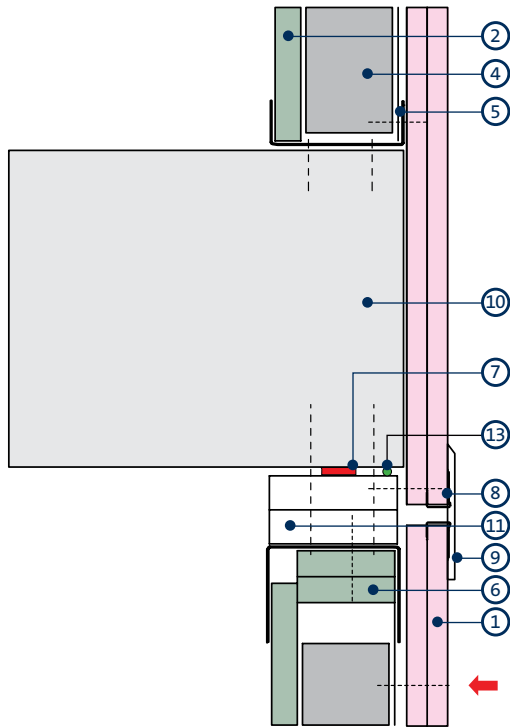
26



Retro-fit non-performance partition junction

## Connection to the structure

27



Control joint at floor slab junction where lining boards continue  
- BS 476 Part 22: 1987

- |   |  |
|---|--|
| <ul style="list-style-type: none"> <li>1 Gyproc FireLine<sup>1</sup></li> <li>2 Gyproc CoreBoard<sup>2</sup></li> <li>3 Gypframe 'T' Stud</li> <li>4 Gypframe Retaining Channel</li> <li>5 Gypframe Floor &amp; Ceiling Channel</li> <li>6 Gyproc CoreBoard fire-stops<sup>2</sup></li> <li>7 Gyproc FireStrip</li> </ul> | <ul style="list-style-type: none"> <li>8 Gyproc Edge Bead - if no cover strip is used</li> <li>9 Cover strip (by others)</li> <li>10 Structure</li> <li>11 Glasroc F FIRECASE</li> <li>12 Gyproc Sealant</li> <li>13 Suitable metal self-drive fixing (by others)</li> </ul> |
|---|--|

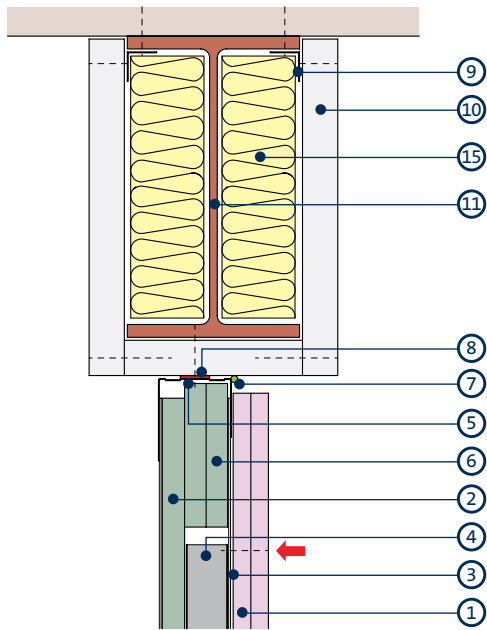
<sup>1</sup> Replace with 15mm Glasroc F FIRECASE for systems with non-combustible linings.

<sup>2</sup> Replace with 20mm Glasroc F FIRECASE for systems with non-combustible linings.

**NB** No fixings should be made through the boards into the flanges of the head channel. The arrow (←) denotes the position of the uppermost board fixing.

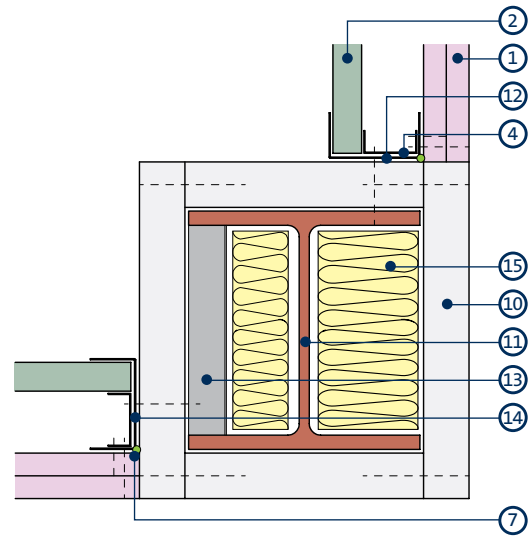
## ShaftWall construction details (continued)

29



Beam encasement and partition junction for partitions to satisfy  
*BS 5234: Parts 1 & 2: 1992 Heavy and Severe Duty Rating*  
 - BS 476 Part 22: 1987

30



Column encasement and partition junction for partitions up to  
 120 minutes fire resistance and *BS 5234 Parts 1 & 2: 1992*  
 Heavy and Severe Duty Rating

- 1 Gyproc FireLine<sup>1</sup>
- 2 Gyproc CoreBoard<sup>2</sup>
- 3 Gypframe 'I' Stud
- 4 Gypframe Retaining Channel
- 5 Gypframe 'J' Channel suitably fixed through encasement to structure
- 6 Gyproc CoreBoard fire-stops<sup>2</sup>
- 7 Gyproc Sealant
- 8 Gyproc FireStrip
- 9 Gypframe GA1 Steel Angle

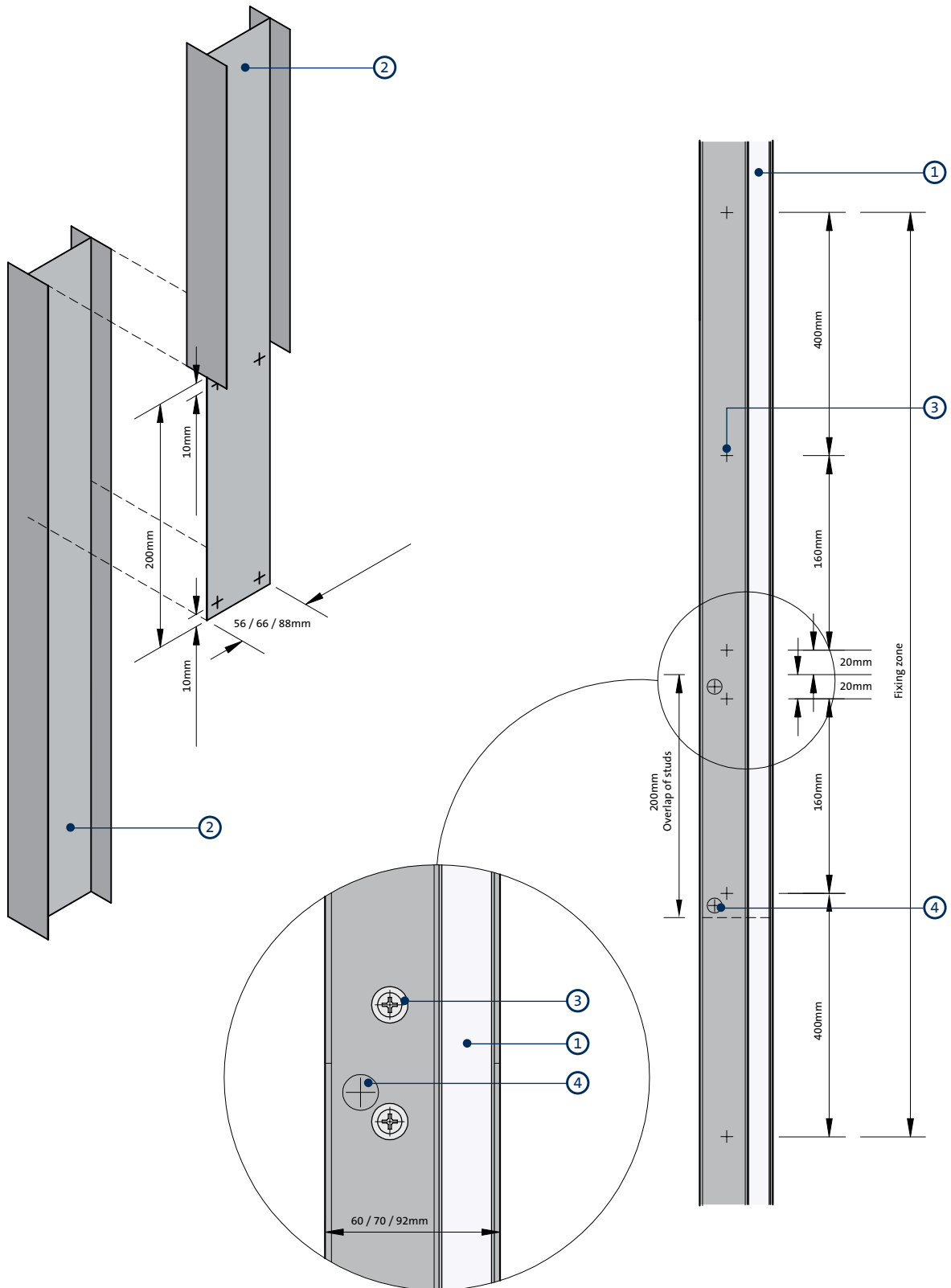
- 10 Glasroc F FIRECASE
- 11 Structural steel
- 12 Gypframe Starter Channel suitably fixed through Glasroc F FIRECASE to column at 600mm centres (in two lines staggered by 300mm for studs wider than 75mm)
- 13 Suitable size Z-section (by others) fixed between column flanges at 600mm centres
- 14 Gypframe Starter Channel suitably fixed through Glasroc F FIRECASE to Z-sections (in two lines staggered by 300mm for studs wider than 75mm).
- 15 Isover insulation if required to minimise acoustic downgrade

<sup>1</sup> Replace with 15mm Glasroc F FIRECASE for systems with non-combustible linings.

<sup>2</sup> Replace with 20mm Glasroc F FIRECASE for systems with non-combustible linings.

**NB** No fixings should be made through the boards into the flanges of the head channel. The arrow (←) denotes the position of the uppermost board fixing.

31



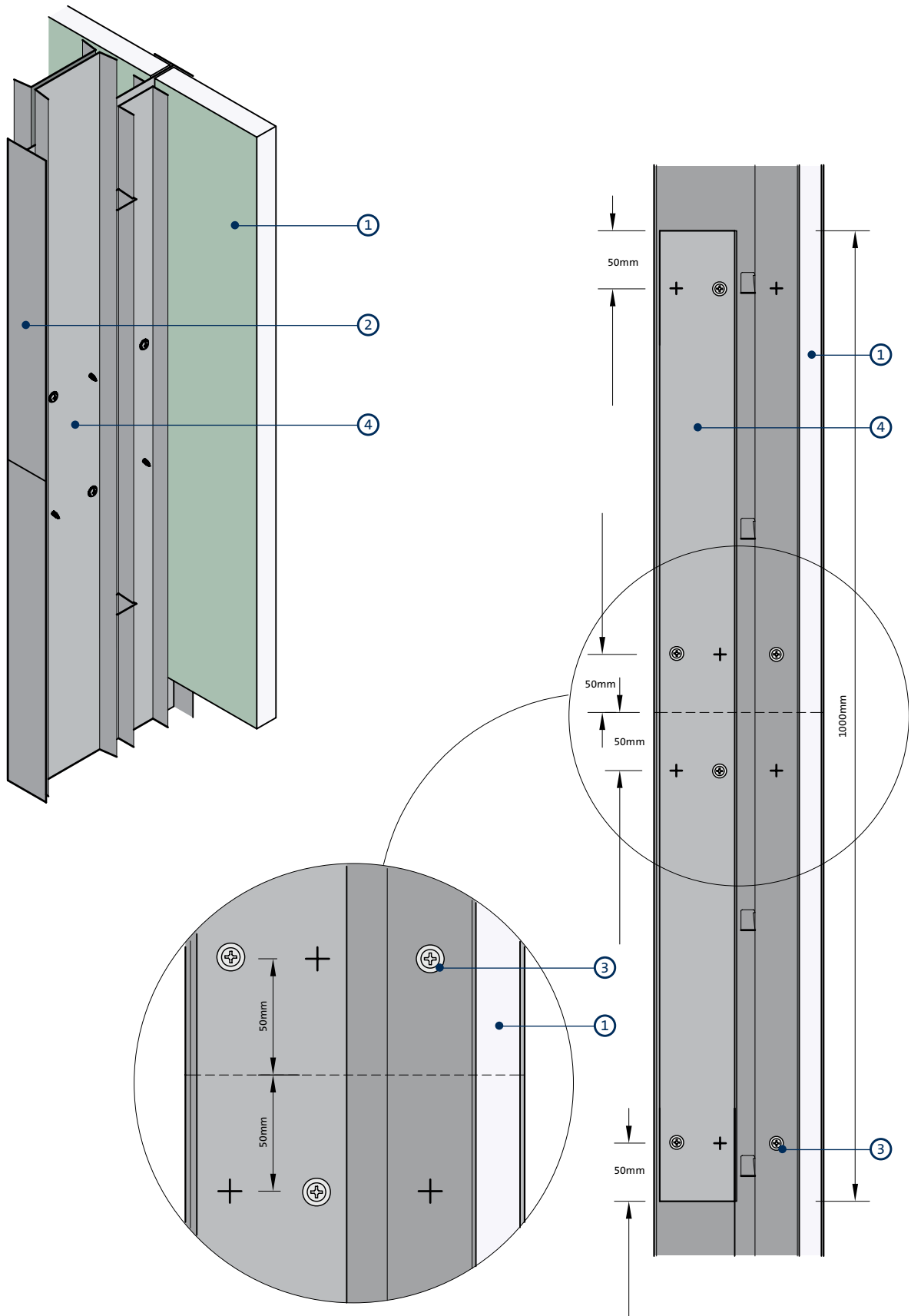
60 / 70 / 92mm T Stud splicing detail

- 1 Gyproc CoreBoard
- 2 Gypframe T Stud

- 3 Gyproc Wafer Head Jack-Point Screw
- 4 14mm dia. pre-drilled hole in Gypframe Retaining Channel to coincide and clear screws connecting overlap of T Studs

## ShaftWall construction details (continued)

32



146mm 'I' Stud splicing detail

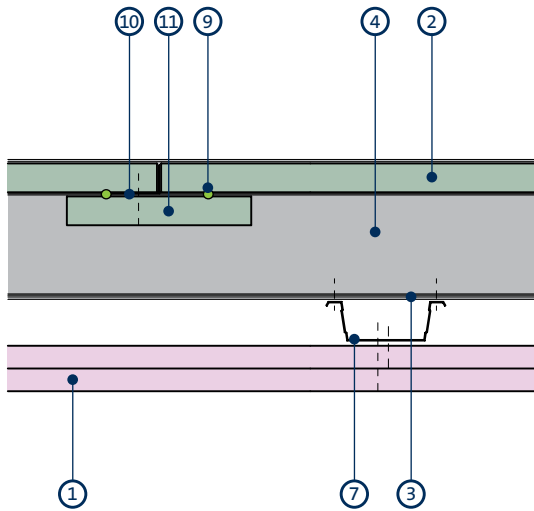
- 1 Gyproc CoreBoard
- 2 Gypframe 'I' Stud

- 3 Gyproc Wafer Head Jack-Point Screw
- 4 Gypframe G105 Retaining Channel

## ShaftWall construction details (continued)

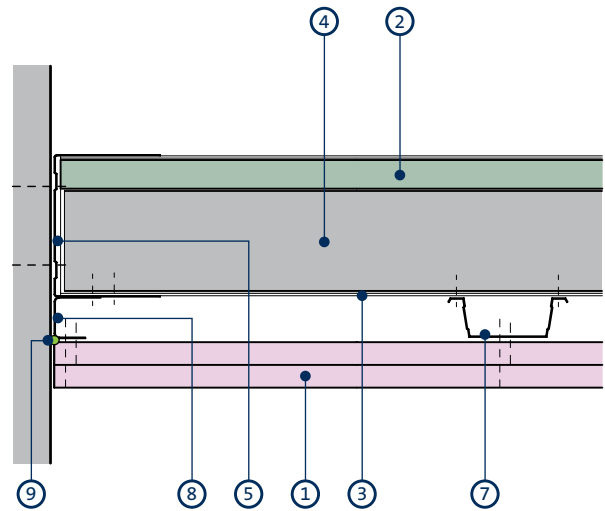
Horizontal ShaftWall (ShaftWall used horizontally should not be used for material storage or access for personnel)

33



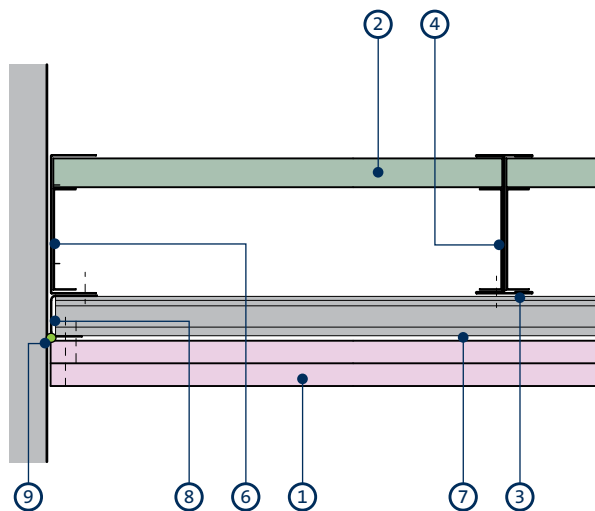
Gyproc CoreBoard joint

34



Perimeter detail 1

35



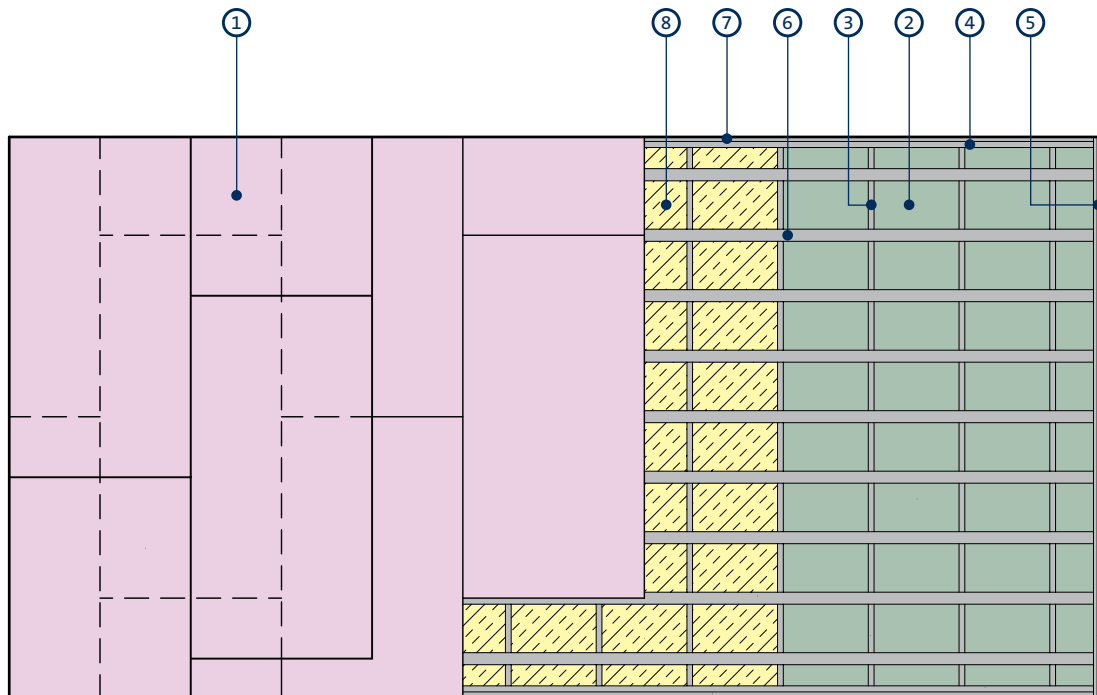
Perimeter detail 2

- |  |   |
|--|---|
| <ul style="list-style-type: none"> <li>1 Gyproc FireLine</li> <li>2 Gyproc CoreBoard</li> <li>3 Gypframe 'T' Stud</li> <li>4 Gypframe Retaining Channel</li> <li>5 Gypframe Extra Deep Flange Floor &amp; Ceiling Channel or Gypframe 'J' Channel</li> </ul> | <ul style="list-style-type: none"> <li>6 Gypframe Starter Channel</li> <li>7 Gypframe MF5 Ceiling Section</li> <li>8 Gypframe MF6 Perimeter Channel</li> <li>9 Gyproc Sealant</li> <li>10 Gypframe GA3 Steel Angle</li> <li>11 122mm wide strip of 19mm Gyproc CoreBoard</li> </ul> |
|--|---|

## ShaftWall construction details (continued)

Horizontal ShaftWall (ShaftWall used horizontally should not be used for material storage or access for personnel)

36

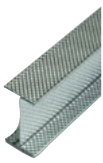


Reflected ceiling

- 1 Gyproc FireLine
- 2 Gyproc CoreBoard
- 3 Gyframe 'T' Stud
- 4 Gyframe Extra Deep Flange Floor & Ceiling Channel or Gyframe 'J' Channel

- 5 Gyframe Starter Channel
- 6 Gyframe MF5 Ceiling Section
- 7 Gyframe MF6 Perimeter Channel
- 8 Isover Acoustic Insulation

## Gypframe metal components



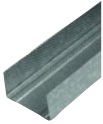
### Gypframe 'I' Studs (60 I 70, 70 I 70, 92 I 90, 146 TI 90 Tabbed)

Enhanced strength stud that allows for partition height, without increasing partition width. Designed to receive fixing of board to one side (face fixed) and to accommodate Gyproc CoreBoard within its flange.



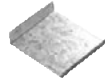
### Gypframe Retaining Channel (G102, G105, G110)

Insert channel to provide support for the Gyproc CoreBoard located within the Gypframe 'I' stud. G102 for 60 I 70 and 146 TI 90 'I' Studs. G105 for 92 I 90 'I' Studs. G110 for 70 I 70 'I' Studs.



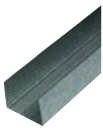
### Gypframe Folded Edge Standard Floor & Ceiling Channels (62 FEC 50, 72 FEC 50, 94 FEC 50, 148 FEC 50)

Standard floor channels for retaining the Gypframe studs at floor junctions for heights not exceeding 4200mm.



### Gypframe Retaining Clips (G108, G109)

Used within Gypframe 'I' studs at deflection heads. G108 for 92 I 90 'I' Studs. G109 for 146 TI 90 'I' Studs.



### Gypframe Deep Flange Floor & Ceiling Channels (62 DC 60, 72 DC 60, 94 DC 60, 148 DC 60)

Floor and ceiling channels with deep flanges for retaining the Gypframe studs at floor and ceiling junctions for partitions 4200mm to 8000mm high. Also used around openings and in deflection heads (maximum 30mm deflection). Also accommodates Gypframe Retaining Clips / Channels and where applicable used around the perimeter in horizontal applications.



### Gypframe GA3 Steel Angle

Steel angle providing framing stability and board support. Used at horizontal joints of Gyproc CoreBoard.



### Gypframe 99 FC 50 Fixing Channel

A versatile metal fixing channel used to support medium weight fixtures on walls.



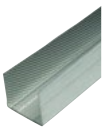
### Gypframe 'J' Channel (62 JC 70)

Channels with uneven flanges for retaining the Gypframe studs at ceiling junctions. Also used around openings and in deflection heads.



### Gypframe GFS1 Fixing Strap

Used to support horizontal board joints.



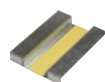
### Gypframe Extra Deep Flange Floor & Ceiling Channels (72 EDC 80, 94 EDC 70, 148 EDC 80)

Floor and ceiling channels with extra deep flanges for retaining the Gypframe studs at floor and ceiling junctions for partitions over 8000mm high. Also used around openings and in deflection heads (maximum 50mm deflection). Also accommodates Gypframe Retaining Clips / Channels and where applicable used around the perimeter in horizontal applications.



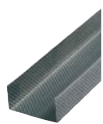
### Gypframe GFT1 Fixing T

Used to support horizontal board joints.



### Gypframe Service Support Plate

For installation of 18mm plywood within a partition cavity to support medium to heavyweight fixtures.



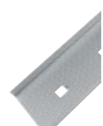
### Gypframe Starter Channels (60 SC 50 at 3600mm, 70 SC 70 at 3600mm or 4200mm, 92 SC 90 at 5000mm or 6000mm)

Vertical stud used at abutments and openings to receive fixing of board.



### Gypframe MF5 Ceiling Section

Secondary section to support fixing of board.



### Gypframe Tabbed Starter Channel (146 TSC 90)

Vertical stud used at abutments and openings to receive fixing of board.



### Gypframe MF6 Perimeter Channel

Perimeter section to support Gypframe MF5 Ceiling Section and fixing of board.

## ShaftWall system components (continued)

### Board products



#### Gyproc FireLine<sup>2</sup>

Gypsum plasterboard with fire resistant additives.



#### Gyproc DuraLine<sup>2</sup>

Gypsum plasterboard with fire resistant additives and a high density core for enhanced sound insulation and impact resistance performance.



#### Gyproc CoreBoard

Gypsum plasterboard with fire and moisture resistant additives. Retained within studs and to form deflection head.



#### Glasroc F FIRECASE<sup>1</sup>

Non-combustible glass-reinforced gypsum board. Also used to form deflection head.

<sup>1</sup> Glasroc F FIRECASE boards used to replace Gyproc CoreBoard on the shaft side of the system must be cut to 598mm wide (+0mm / -3mm).

<sup>2</sup> Also available in a Moisture Resistant (MR) version. MR boards are specified in intermittent wet use areas.

### Fixing products



#### Gyproc Drywall Screws

Corrosion resistant self-tapping steel screws for fixing board-to-timber and board-to-metal framing less than 0.8mm thick ('I' Studs less than 0.6mm thick).



#### Gyproc Jack-Point Screws

Corrosion resistant self-tapping steel screws for fixing board to metal framing 0.8mm thick and greater ('I' Studs 0.6mm thick and greater).



#### Gyproc Collated Drywall Screws

Corrosion resistant self-tapping steel screws for fixing board-to-timber and board-to-metal framing less than 0.8mm thick ('I' Studs less than 0.6mm thick).



#### Gyproc Wafer Head Jack-Point Screws

Corrosion resistant self-tapping steel screws for fixing metal to metal framing 0.8mm thick and greater ('I' Studs 0.6mm thick and greater).



#### Gyproc Wafer Head Drywall Screws

Corrosion resistant self-tapping steel screws for fixing metal to metal framing less than 0.8mm thick ('I' Studs less than 0.6mm thick).

### Plasterboard accessories



#### Gyproc Jointing Materials

Jointing compounds, ready mixes and adhesives for reinforcement and finishing of board joints.



#### Gyproc Sealant

Used to seal air paths for optimum sound insulation.



#### Gyproc FireStrip

A soft extruded linear intumescent gap sealer to maintain fire resistance located directly to the underside of the soffit when forming a deflection head.



#### Gyproc Paper Joint Tape

A paper tape designed for reinforcement of flat joints or internal angles.



#### Gyproc Corner Tape

A paper tape bonded to two corrosion resistant steel strips.



#### Gyproc Drywall Primer

Used to prepare for painting. Tub contents 10 litre.

## ShaftWall system components (continued)

### Finishing products

---

**Gyproc Skimcoat**

To provide a plaster skim finish on most common backgrounds including undercoat plasters and plasterboard.

**Gyproc Carlite Finish**

To provide a plaster skim finish on most common backgrounds including undercoat plasters and plasterboard.

**Gyproc Carlite Ultra Finish**

Offers all the benefits of Gyproc Skimcoat and Gyproc Carlite Finish with a reduced set time of 90-120mins, making it ideal for smaller jobs.

**Plaster accessories**

Designed for the reinforcement and finishing of board joints before plaster skimming.

### Insulation products

---

**Isover Acoustic Roll**

Glass mineral wool for enhanced acoustic and thermal performance.

## ShaftWall installation overview

This is intended to be a basic description of how the system is built.



The appropriate Gypframe channels, are suitably fixed to the floor and soffit of the structure. Gyproc FireStrip is used on the channel at the soffit.



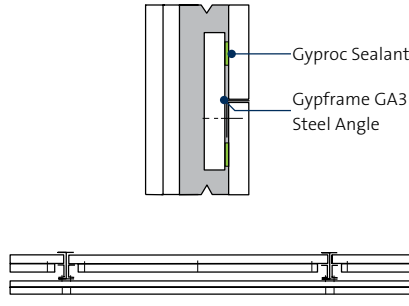
Gypframe Starter Channels are suitably fixed to vertical abutments. The perimeter of the partition is sealed with Gyproc Sealant.



Gypframe 'I' Studs or Gypframe Tabbed 'I' Studs are friction fitted into the channels at 600mm required centres. Gyproc CoreBoard or 20mm Glasroc F FIRECASE is fitted between the studs on the shaft side, and held in place with appropriate Gypframe Retaining Channels. Door openings are formed to the ShaftWall Access Door Details.



Pressurised shafts and service ducts are sealed using Gyproc Sealant. This is applied to all board-to-metal junctions.



Horizontal board joints are fire stopped using Gypframe GA3 Angle and strips of Gyproc CoreBoard from the non-shaft side.



Isover Acoustic Roll can be added to the partition cavity for increased acoustic performance.



Gyproc plasterboard or Glasroc F FIRECASE are then fixed to the Gypframe framework with Gyproc Drywall Screws or Gyproc Jack-Point Screws.



### Additional information

For full installation details, refer to the **Gyproc Installation Guide**, available to download from [gyproc.ie](http://gyproc.ie)



# FireWall

High performance fire-resistant wall system

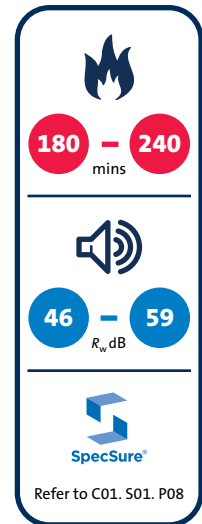


## FireWall

**FireWall** is a lightweight, non-loadbearing wall capable of providing up to 240 minutes fire resistance. It is commonly specified in areas that contain business-critical items such as computer servers or data storage equipment. It is also specified where fire-spread containment is required, for example, in plant rooms.

### Key benefits

- Satisfies insurance company requirements for enhanced performance
- Reduction of the structural load is achieved through this lightweight alternative solution to traditional masonry construction
- Increased fire resistance is achieved without compromising partition thickness through the use of non-combustible Glasroc F glass-reinforced gypsum boards
- No additional framing components required on site due to the use of standard Gypframe metal products that are widely used in other Gyproc partition solutions



### You may also be interested in...

For assistance in choosing the right solution for your project, try our **System Selector**; an online tool that enables quick and easy filtering by performance criteria. It provides system specific downloads including:

- BIM (Revit) objects
- Specification Clauses
- System and product data sheets

► Refer to [gyproc.ie](http://gyproc.ie)

## FireWall performance (continued)

### Gypframe 70mm and 146mm 'C' Studs and Gypframe 92mm 'I' Studs - two and three layer board linings

For details of when to specify fire resistance using EN / BS  
 ▶ Refer to C02, S01, P18



Table 1 — Solutions to satisfy requirements of BS EN 1364-1: 1999 and BS 476: Part 22: 1987

①	②	③	④
Three layers of board each side of 70 S 50 Gypframe 'C' Studs at 600mm centres. Linings as in table.	Three layers of board each side of 146 S 50 Gypframe 'C' Studs at 600mm centres. Linings as in table.	Two layers of board each side of Gypframe 92 I 90 'I' Studs at 600mm centres and located in Gypframe Extra Deep Flange Floor & Ceiling Channel. 90mm thickness of stone mineral wool 100kg/m <sup>3</sup> (40mm & 50mm batts) in the cavity. Linings as in table.	Three layers of board each side of Gypframe 92 I 90 'I' Studs at 600mm centres and located in Gypframe Extra Deep Flange Floor & Ceiling Channel. 90mm thickness of stone mineral wool 100kg/m <sup>3</sup> (40mm & 50mm batts) in the cavity. Linings as in table.

Detail	Partition thickness mm	Board type	Lining thickness mm	Maximum partition height <sup>1</sup> mm	Sound insulation R <sub>w</sub> dB	Duty rating	Approx. weight kg/m <sup>2</sup>	System reference
<b>180 minutes fire resistance (EN)</b>								
①	162	Gyproc FireLine	3 x 15	4000	46	Severe	73	A206252
②	238	Gyproc FireLine	3 x 15	4000	50	Severe	73	A206256
<b>180 minutes fire resistance (BS)</b>								
③	154	Glasroc F FIRECASE	2 x 15 <sup>2</sup>	6900 <sup>3</sup>	56	Severe	60	G106I019
①	162	Gyproc FireLine	3 x 15	4900 <sup>4</sup>	46	Severe	73	A206252
②	238	Gyproc FireLine	3 x 15	7900 <sup>4</sup>	50	Severe	73	A206256
<b>240 minutes fire resistance (BS)</b>								
④	166	Glasroc F FIRECASE + Glasroc F MULTIBOARD	2 x 15 + 1 x 6	6900 <sup>3</sup>	59	Severe	73	G106I018

▶ For further assistance in choosing the right solution for your project, try our System Selector; an online tool that enables quick and easy filtering by performance criteria. It provides system specific information downloads including BIM (Revit) objects. Go to [gyproc.ie](http://gyproc.ie)

<sup>1</sup> Maximum wall heights quoted are limited by the fire state field of application or by limiting deflection of L/240 at 200 Pa, whichever is more onerous.

<sup>2</sup> Actual test result gave 240 mins integrity : 222 mins insulation.

<sup>3</sup> Gypframe Extra Deep Flange Floor & Ceiling Channel should be used at the head. For heights between 4200mm and 7600mm Gypframe Deep Flange Floor & Ceiling Channel should be used at the base.

<sup>4</sup> For heights between 4200mm and 7600mm, Gypframe Deep Flange Floor & Ceiling Channel should be used at base and at head (subject to deflection criteria). For heights above 7600mm Gypframe Extra Deep Flange Floor & Ceiling Channel should be used at the base and at the head.

**(NB)** The fire resistance and sound insulation performances are for imperforate partitions, walls and ceilings incorporating boards with all joints taped and filled, or skimmed according to Gyproc's recommendations. The quoted performances are achieved only if Gyproc and Isover components are used throughout, and the Company's fixing recommendations are strictly observed. Any variation in the specifications should be checked with Gyproc.

# FireWall design

## Building design

FireWall comprises Gypframe 'C' or 'I' Studs within Gypframe Floor & Ceiling Channels. The position of services should be pre-determined and their installation planned into the frame erection stage.

## Fixing floor and ceiling channels

Gypframe Floor & Ceiling Channels must be securely fixed with a row of fixings at 600mm maximum centres. For 94mm channels and above, two rows of staggered fixings are required, each row at 600mm centres and each fixing 25mm in from the flange. If the floor is uneven, a 38mm thick timber sole plate equal to the width of the channel should be used.

If the concrete or screeded floor is new, consideration should be given to the installation of a damp-proof membrane between the floor surface and the channel or sole plate.

## Splicing

To extend studs, overlap by 600mm (minimum). Fix together using Gyproc Wafer Head Drywall Screws or steel pop rivets (two to each flange).

▶ Refer to C04. S01. P110 – Partitions introduction, construction detail 1.

## Partition to structural steelwork junctions

When designing the layout of rooms requiring separation by sound insulating walls abutting structural steelwork, consideration should be given to the potential loss of sound insulation performance through the steelwork.

▶ Refer to C02. S01. P21 – Building acoustics.

## Openings

FireWall is used to divide space into fire compartments and, as such, openings are generally not required. If openings are to be specified they must be shown by fire test to maintain the fire performance of the wall.

## Cavity fire barriers

Where required to maintain fire performance, suitable fire stopping (by others) should be installed full filled within the partition cavity to form a suitable closure.

▶ Refer to C06. S06. P422 – Cavity fire barriers.

## Deflection heads

Partition head deflection designs may be necessary to accommodate deflections in the supporting floor. Deflection heads may also be required to the underside of roof structures subjected to positive and negative pressures (see construction detail 1).

▶ Refer to C04. S01. P116 – Partitions introduction, construction details 15-21.

## Services

### Penetrations

Penetrations of fire-resistant or sound-insulating constructions for services need careful consideration to ensure that the performance of the element is not downgraded and also that the services themselves do not act as the mechanism of fire spread or sound transmission.

▶ Refer to C02. S01. P41 – Service installations.

## Electrical

The installation of electrical services should be carried out in accordance with BS 7671. The cut-outs in the studs can be used for routing electrical and other small services.

▶ Refer to C04. S01. P110 – Partitions introduction, construction detail 2.

Switch boxes and socket outlets can be supported from Gypframe 99 FC 50 Fixing Channel fixed horizontally between studs, or a high performance socket box detail where higher acoustic performance is required i.e. chosen socket solution must be able to provide fire resistance to match the partition system.

## Independent support

When designing for the installation of services such as fire dampers and associated ductwork through a FireWall partition, consideration should be given to the size and weight of the damper - this will determine whether it can be supported directly from the partition or needs to be independently supported from the structure.

▶ Refer to C04. S01. P122 – Partitions introduction, construction details 29-31.

## Fixtures

Lightweight fixtures can be made directly to the partitions. Medium weight fixtures can be made to Gypframe 99 FC 50 Fixing Channel. Heavyweight fixtures (to BS 5234), such as wash basins and wall cupboards, can be fixed to plywood using Gypframe Service Support Plates.

▶ Refer to C02. S01. P41 – Service installations.

## Board finishing

▶ Refer to C08. S01. P483 – Finishes.

## Tiling

Tiles can be applied to the surface of lightweight partition systems.

▶ Refer to C08. S04. P498 – Tiling.

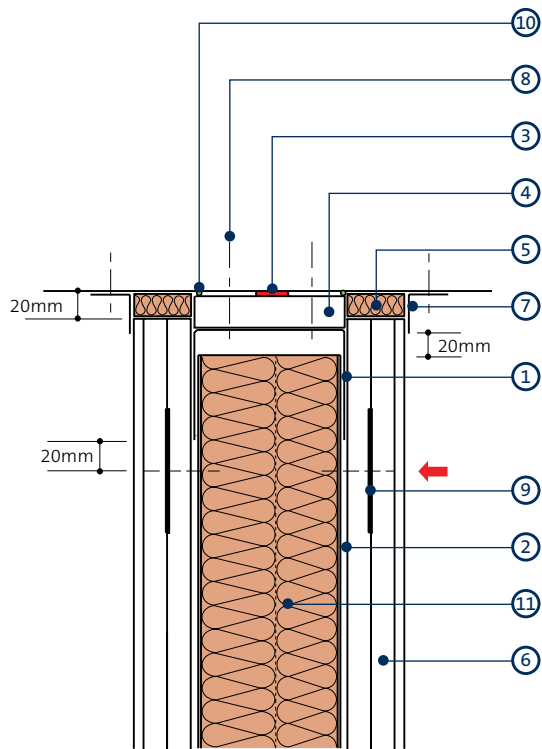


## Handy hint

If horizontal board joints are necessary, they should be staggered between layers by a minimum of 600mm to avoid downgrading performance.

## FireWall construction details

1



Deflection head for 15mm downward movement  
up to 240 minutes fire resistance  
- BS 476 Part 22: 1987

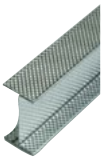
- 1 Gypframe Extra Deep Flange Floor & Ceiling Channel
- 2 Gypframe 'T' Stud
- 3 Gyproc FireStrip (continuous line)
- 4 30mm Glasroc F FIRECASE forming fire-stop
- 5 Stone mineral wool (by others)
- 6 Glasroc specialist boards / Gyproc fire boards

- 7 Gypframe GA4 Steel Angle
- 8 Staggered rows of fixings through fire-stop
- 9 Gypframe GFS1 Fixing Strap
- 10 Gyproc Sealant
- 11 Stone mineral wool (by others) if required

**NB** No fixings should be made through the boards into the flanges of the head channel. The arrow (←) denotes the position of the uppermost board fixing which should be made into Gypframe GFS1 Fixing Strap. Continuous Gyproc FireStrip must be installed as shown to maintain fire performance.

# FireWall system components

## Gypframe metal components



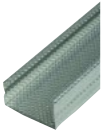
### Gypframe 'I' Studs (92 I 90)

Enhanced strength stud that allows for greater partition height, without increasing partition width. Designed to receive fixing of board to both sides and enhance the fire performance of the partition.



### Gypframe 99 FC 50 Fixing Channel

A versatile metal fixing channel used to support medium weight fixtures on walls.



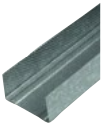
### Gypframe 'C' Studs (70 S 50, 92 S 50, 146 S 50)

Vertical stud providing acoustic and structural performances designed to receive fixing of board to both sides.



### Gypframe GFS1 Fixing Strap

Used to support horizontal board joints and within deflection heads.



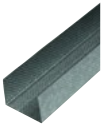
### Gypframe Folded Edge Standard Floor & Ceiling Channels (72 FEC 50, 94 FEC 50, 148 FEC 50)

Standard floor channels for retaining the Gypframe studs at floor junctions and around openings to heights not exceeding 4200mm.



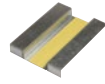
### Gypframe GA4 Steel Angle

Steel angle providing framing stability and board support. Used at deflection head.



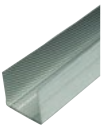
### Gypframe Deep Flange Floor & Ceiling Channels (72 DC 60, 94 DC 60, 148 DC 60)

Floor and ceiling channels with deep flanges for retaining the Gypframe studs at floor and ceiling junctions for partitions 4200mm to 8000mm high.



### Gypframe Service Support Plate

For installation of 18mm plywood within a partition cavity to support medium to heavyweight fixtures.



### Gypframe Extra Deep Flange Floor & Ceiling Channels (72 EDC 80, 94 EDC 70, 148 EDC 80)

Floor and ceiling channels with extra deep flanges for retaining the Gypframe studs at floor and ceiling junctions for partitions over 8000mm high.

## Board products



### Glasroc F FIRECASE

Non-combustible glass-reinforced gypsum board. Also used to form deflection heads.



### Gyproc FireLine<sup>1</sup>

Gypsum plasterboard with fire resistant additives.



### Glasroc F MULTIBOARD

Non-combustible glass-reinforced gypsum board.

<sup>1</sup>Also available in a Moisture Resistant (MR) version. MR boards are specified in intermittent wet use areas.

## Fixing products



### Gyproc Drywall Screws

Corrosion resistant self-tapping steel screws for fixing board-to-timber and board-to-metal framing less than 0.8mm thick ('I' studs less than 0.6mm thick).



### Gyproc Jack-Point Screws

Corrosion resistant self-tapping steel screws for fixing board to metal framing 0.8mm thick and greater.



### Gyproc Collated Drywall Screws

Corrosion resistant self-tapping steel screws for fixing board-to-timber and board-to-metal framing less than 0.8mm thick ('I' studs less than 0.6mm thick).



### Gyproc Wafer Head Jack-Point Screws

Corrosion resistant self-tapping steel screws for fixing metal to metal framing 0.8mm thick and greater ('I' studs 0.6mm thick and greater).



### Gyproc Wafer Head Drywall Screws

Corrosion resistant self-tapping steel screws for fixing metal to metal framing less than 0.8mm thick ('I' studs less than 0.6mm).



### Glasroc F FIRECASE Screws

Corrosion resistant self-tapping steel screws for fixing 6mm Glasroc F MULTIBOARD to Glasroc F FIRECASE.

## FireWall system components (continued)

### Plasterboard accessories



#### Gyproc Jointing Materials

Jointing compounds, ready mixes and adhesives for reinforcement and finishing of board joints.



#### Gyproc FireStrip

A soft extruded linear intumescent gap sealer to maintain fire resistance located directly to the underside of the soffit when forming a deflection head.



#### Gyproc Corner Tape

A paper tape bonded to two corrosion resistant steel strips.



#### Gyproc Sealant

Used to seal air paths for optimum sound insulation.



#### Gyproc Paper Joint Tape

A paper tape designed for reinforcement of flat joints or internal angles.



#### Gyproc Drywall Primer

Used to prepare for painting. Tub contents 10 litre.

### Finishing products



#### Gyproc Skimcoat

To provide a plaster skim finish on most common backgrounds including undercoat plasters and plasterboard.



#### Gyproc Carlite Finish

To provide a plaster skim finish and provide up to 60% tougher resistance to accidental damage.



#### Gyproc Carlite Ultra Finish

Offers all the benefits of Gyproc Skimcoat and Gyproc Carlite Finish with a reduced set time of 90-120mins, making it ideal for smaller jobs.



#### Gyproc Magnetic Plaster

To provide a plaster skim finish that provides an attraction to magnets used to finish a wide range of backgrounds, including undercoat plasters and plasterboard.

### Insulation products

#### Stone Mineral Wool (100kg/m<sup>3</sup> by others)

For fire stopping.

## FireWall installation overview

This is intended to be a basic description of how the system is built.



Gypframe Floor & Ceiling Channels are suitably fixed to the floor and soffit.



Gypframe 'C' Studs are suitably fixed to abutments and at openings.



Gypframe 'I' Studs or 'C' Studs are then friction fitted into the Gypframe Channels at required centres.



Door openings are constructed to the Heavy and Severe Duty Rating.



The perimeter of the partition is then sealed on both sides with Gyproc Sealant.



M&E services can be located within the partition cavity.



Stone mineral wool insulation (by others) may also be added to the partition cavity for increased performance.



The appropriate lining boards are screw-fixed to framing members to form the lining, except 6mm Glasroc F MULTIBOARD, which is screw-fixed to the Glasroc F FIRECASE linings.



### Additional information

For full installation details, refer to the **Gyproc Installation Guide**, available to download from [gyproc.ie](http://gyproc.ie)

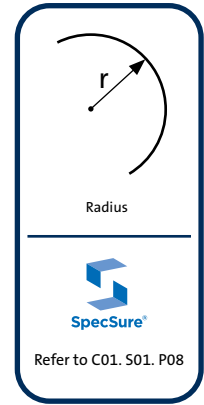
# GypWall CURVE

Curved partition and wall lining system



# GypWall CURVE

**GypWall CURVE** is a lightweight system specifically designed to provide curved walls and linings down to a radius of 600mm. This system provides a high degree of design flexibility and can be used to create imaginative spaces with great aesthetic impact.



## Key benefits

- Cost-effective and easy-to-install solution compared to other forms of construction due to the innovative Gypframe 72 EDCL 80 Curveliner Channel and its expandable outer flange
- Compatible with other **GypWall** partition systems - only the Gypframe 72 EDCL 80 Curveliner Channel is unique to this system, minimising the number of components required on site
- No need for a curved timber template for laying out
- Can be installed as a lining to existing structures by using Gypframe 'I' Studs and boarding to one side only
- A smooth seamless finish is achieved through the use of our range of Gyproc Finish Plasters



# GypWall CURVE performance

**Table 1 – Minimum bending radii and stud centres**

Board type	Thickness mm	Minimum radius mm <sup>1</sup>	Stud centres mm <sup>2</sup>
Glasroc F MULTIBOARD	6	600	300
	10	2500	300
	12 (2 x 6)	600	300
	12.5	2700	300
Gyproc WallBoard	9.5	1800	300
	12.5	3600	300
	15	4800	300
Gyproc FireLine	12.5	4800	300
	15	5700	400
Gyproc SoundBloc	12.5	2900	300
	15	3600	300
Gyproc DuraLine	15	5700	400

<sup>1</sup> Concave or convex.

<sup>2</sup> For any radius 7000mm or more, studs can be installed at 600mm centres irrespective of board type with the exception of 6mm Glasroc F MULTIBOARD.

**NB** Double layer specifications can be used if required to meet specific performance criteria.

**Table 2 – Recommended maximum heights using Glasroc F MULTIBOARD**

Stud type	1 x 6mm each side <sup>1</sup>	2 x 6mm each side	1 x 10mm each side	2 x 10mm each side
Single 70 S 50	3400	3600	3500	4200
Boxed 70 S 50	3700	3900	3800	4500
Single 70 S 60	3600	3700	3700	4400
Single 70 AS 50	3700	3800	3800	4400
Boxed 70 S 60	3900	4100	4000	4600
Boxed 70 AS 50	4000	4100	4100	4700
Single 70 I 50	3900	4100	4000	4600
Single 70 I 70	4500	4500	4500	5000

<sup>1</sup> Studs at maximum 300mm centres. Gypframe 72 EDCL 80 should be used at head and base. Refer to table 1 for minimum bending radii and stud centres.



## Important information

When installing a curve lining with board to one side only, Gypframe 'I' Studs must be used. Gypframe 'C' Studs may only be used when board is installed to both sides.

▶ Refer to C07. S05. P468 – GypLyner iwL

## Building design

GypWall CURVE comprises 70mm Gypframe Studs within Gypframe 72 EDCL 80 Curvelynner Channel.

## Planning – key factors

The positioning of vertical board joints on exposed board layers at the apex of the curve should be avoided. The positioning of all studs, therefore, needs to be determined at the design stage. Where straight runs occur within curved partitions or linings, stud centres can be increased as determined by the specification, once 600mm off the curve.

## Fixing floor and ceiling channels

Gypframe 72 EDCL 80 Curvelynner Channels must be securely fixed in two lines at 300mm centres in each line. If the floor is uneven, a 38mm thick timber sole plate equal to the width of the channel should be used.

If the concrete or screeded floor is new, consideration should be given to the installation of a damp-proof membrane between the floor surface and the channel or sole plate.

## Splicing

To extend studs, overlap by 600mm (minimum). Fix together using Gyproc Wafer Head Drywall Screws or steel pop rivets (two to each flange).

▶ Refer to Partitions introduction C04. S01. P110 – construction detail 1.

## Partition to structural steelwork junctions

When designing the layout of rooms requiring separation by sound insulating walls abutting structural steelwork, consideration should be given to the potential loss of sound insulation performance through the steelwork.

▶ Refer to C02. S01. P21 – Building acoustics.

## Moisture resistance

Glasroc H TILEBACKER can be used as a substrate for tiling, but should not be exposed to running water. Care should be taken not to over tighten screws when fixing boards and all screw heads should be fully filled with adhesive.

## Fire resistance

There is no specific standard against which to test curved walls and linings, but adhoc testing has been carried out which indicates that a slight downgrade in performance may occur compared to that claimed for the straight partition. This will depend on the system selected, e.g. board specification and radius, and in some instances a downgrade in resistance level may not occur. For specification purposes the worst case scenario is a 30 minute downgrade, e.g. for 30 minutes select a 60 minutes board specification.

## Impact resistance

Glasroc F MULTIBOARD offers a high degree of impact resistance. It also has excellent mechanical properties, is not brittle and therefore is not prone to cracking or shattering when handled.

## Degree of curvature

In common with other sheet materials, board-ends have a tendency to remain straight. The minimum radius, therefore, will be influenced by the board characteristics, the length of curve, the support centres, and the occurrence of board joints.

## Sound insulation

Reducing the centres of the metal studs within GypWall CURVE can have a detrimental effect on sound insulation. Include 25mm Isover Acoustic Roll in the cavity for optimised acoustic performance.

▶ Refer to C02. S01. P37 – Robustness.

## Services

### Penetrations

Penetrations of fire-resistant or sound-insulating constructions for services need careful consideration to ensure that the performance of the element is not downgraded. Consideration also needs to be given to the services themselves so they do not act as the mechanism of fire spread or sound transmission.

▶ Refer to C02. S01. P41 – Service installations.

### Electrical

The installation of electrical services should be carried out in accordance with BS 7671. The cut-outs in the studs can be used for routing electrical and other small services.

▶ Refer to Partitions Introduction C04. S01. P110 – construction detail 2.

Where Gypframe AcouStuds are used, services are routed through 50mm x 28mm 'H' shaped push-outs, at the same centres as shown in Partitions Introduction C04. S01. P110 – construction detail 2a for conventional cut-outs. Cables should be protected by conduit, or other suitable precautions taken to prevent abrasion when they pass through the metal frame.

### Independent support

When designing for the installation of services such as fire dampers and associated ductwork through a GypWall partition, consideration should be given to the size and weight of the damper - this will determine whether it can be supported directly from the partition or needs to be independently supported from the structure.

▶ Refer to Partitions introduction C04. S01. P122 – construction details 29-31.

## GypWall CURVE design (continued)

### Fixtures

Lightweight fixtures can be made directly to the partition linings.

- ▶ Refer to C02. S01. P41 – Service installations.

### Board finishing

A superior finish is easily achieved by applying Gyproc Finish Plasters.

- ▶ Refer to C08. S01. P483 – Finishes.

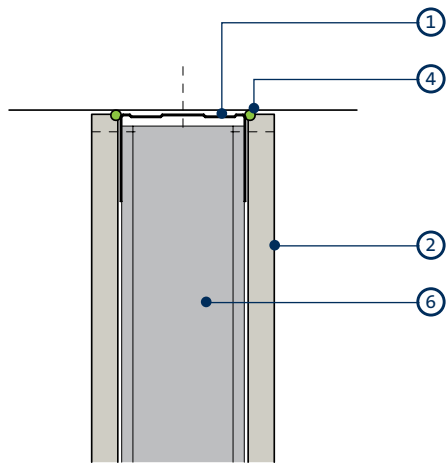
### Tiling

Tiles up to 32kg/m<sup>2</sup> can be applied to the surface of lightweight partition systems.

- ▶ Refer to C08. S04. P498 – Tiling.

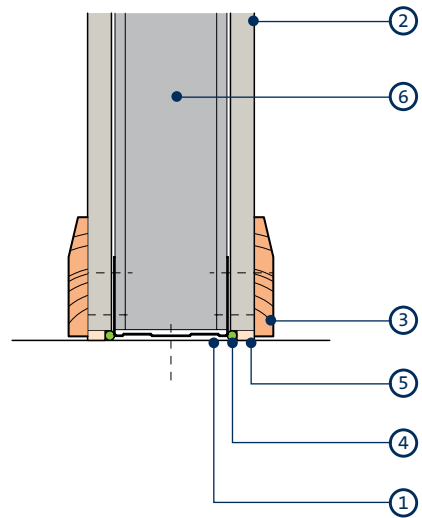
# GypWall CURVE construction details

1



Head

2



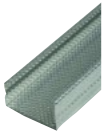
Base

- 1 Gypframe 72 EDCL 80 Curvelyner Channel
- 2 Gyproc plasterboard or Glasroc F MULTIBOARD
- 3 Skirting
- 4 Gyproc Sealant
- 5 Bulk fill with Gyproc jointing materials (where gap exceeds 5mm)

- 6 Gyframe Studs

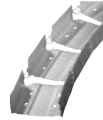
# GypWall curve system components

## Gypframe metal components



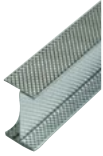
### Gypframe 'C' Studs (70 S 50, 70 S 60)

Vertical stud providing acoustic and structural performances designed to receive fixing of board to both sides.



### Gypframe 72 EDCL 80 Curvelyner Channel

A flexible metal channel with expandable outer flanges for retaining wall studs at floor and ceiling junctions (maximum 50mm total deflection).



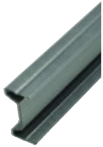
### Gypframe 'I' Studs (70 I 50, 70 I 70)

Enhanced strength stud that allows for greater partition height, without increasing partition width. Designed to receive fixing of board.



### Gypframe GFS1 Fixing Strap

Used to support horizontal board joints.



### Gypframe AcouStud (70 AS 50)

Acoustically enhanced vertical stud designed to receive fixing of board to both sides.

## Board products



### Glasroc F MULTIBOARD

Non-combustible glass-reinforced gypsum board.



### Gyproc FireLine<sup>1</sup>

Gypsum plasterboard with fire resistant additive.



### Gyproc DuraLine<sup>1</sup>

Gypsum plasterboard with fire resistant additives and a high density core for enhanced sound insulation and impact resistance performance.



### Gyproc SoundBloc<sup>1</sup>

Gypsum plasterboard with a high density core for enhanced sound insulation performance.



### Glasroc F FIRECASE

Non-combustible glass-reinforced gypsum board used to form deflection head.



### Gyproc WallBoard

Standard gypsum plasterboard.

<sup>1</sup> Also available in a Moisture Resistant (MR) version. MR boards are specified in intermittent wet use areas.

## GypWall CURVE system components (continued)

### Fixing products



#### Gyproc Drywall Screws

Corrosion resistant self-tapping steel screws for fixing board-to-timber and board-to-metal framing less than 0.8mm thick ('I' studs less than 0.6mm thick).



#### Gyproc Jack-Point Screws

Corrosion resistant self-tapping steel screws for fixing board to metal framing 0.8mm thick and greater ('I' studs 0.6mm thick and greater).



#### Gyproc Collated Drywall Screws

Corrosion resistant self-tapping steel screws for fixing board-to-timber and board-to-metal framing less than 0.8mm thick ('I' studs less than 0.6mm thick).



#### Gyproc Wafer Head Jack-Point Screws

Corrosion resistant self-tapping steel screws for fixing metal to metal framing 0.8mm thick and greater ('I' studs 0.6mm thick and greater).



#### Gyproc Wafer Head Drywall Screws

Corrosion resistant self-tapping steel screws for fixing metal to metal framing less than 0.8mm thick ('I' studs less than 0.6mm thick).

### Plasterboard accessories



#### Gyproc FireStrip

A soft extruded linear intumescent gap sealer to maintain fire resistance located directly to the underside of the soffit when forming a deflection head.



#### Gyproc Sealant

Used to seal air paths for optimum sound insulation.



#### Gyproc Paper Joint Tape

A paper tape designed for reinforcement of flat joints or internal angles.

### Finishing products



#### Gyproc Skimcoat

To provide a plaster skim finish on most common backgrounds including undercoat plasters and plasterboard.



#### Gyproc Carlite Finish

To provide a plaster skim finish on most common backgrounds including undercoat plasters and plasterboard.



#### Gyproc Carlite Ultra Finish

Offers all the benefits of Gyproc Skimcoat and Gyproc Carlite Finish with a reduced set time of 90-120mins, making it ideal for smaller jobs.



#### Gyproc Magnetic Plaster

To provide a plaster skim finish that provides an attraction to magnets used to finish a wide range of backgrounds, including undercoat plasters and plasterboard.

## GypWall CURVE system components (continued)

### Finishing products

---



#### **Plaster accessories**

Designed for the reinforcement and finishing of board joints before plaster skimming.

---

### Insulation products

---



#### **Isover Acoustic Roll**

Glass mineral wool for enhanced acoustic and thermal performance.

---

# GypWall curve installation overview

This is intended to be basic description of how the system is built.



Gypframe 72 EDCL 80 Curvellyner Channels are suitably fixed to the floor and soffit, bent by hand to suit the required radius.



Gypframe 'C' Studs are suitably fixed to abutments.



The perimeter of the partition is then sealed on both sides with Gyproc Sealant.



Gypframe studs are fitted and fixed into the Gypframe 72 EDCL 80 Curvellyner Channels at the required centres.



M&E services can be located within the partition cavity.



Isover Acoustic Roll insulation can also be included within the partition cavity for optimised acoustic performance.



Gyproc plasterboards or Glasroc specialist boards are then fixed to the Gypframe framework with Gyproc Drywall or Jack-Point Screws. The plasterboards are fixed horizontally, with all joints staggered. Additional studs may be required where multiple layers are specified to account for the difference that arises between inner and outer radii.



For best results Gyproc plaster is applied with firm pressure, built out to the required thickness in two applications and trowelled to a smooth matt finish. Good site practice should be followed, as outlined in *BS EN 13914 - 2: Design Considerations and Essential Principles for Internal Plastering*.



## Additional information

For full installation details, refer to the **Gyproc Installation Guide**, available to download from [gyproc.ie](http://gyproc.ie)

# GypWall SECURE

Attack-resistant security wall system

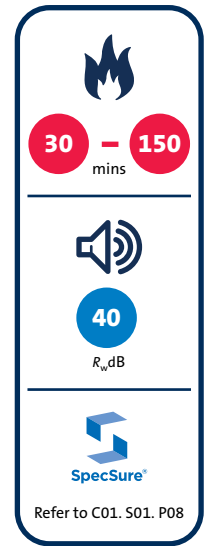


# GypWall SECURE

**GypWall SECURE** is a lightweight, non-loadbearing security wall, offering high resistance to determined attack using hand tools, making it ideal for cash desks, data centres and pharmacy stores.

## Key benefits

- If an increased level of security is required, additional steel sheets can easily be incorporated into the system
- Enhanced fire performance through non-combustible Glasroc F MULTIBOARD linings
- Floor area is maximised due to the system's narrow footprint of only 70mm
- Reduction of the structural load is achieved through this lightweight alternative solution to traditional masonry construction



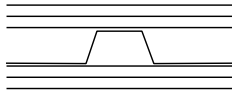
# GypWall SECURE performance

For details of when to specify fire resistance using EN  
 ▶ Refer to C02. S01. P18



**Table 1a — Solutions to satisfy requirements of BS EN 1364-1: 1999**

①



Two layers of board each side of Gypframe Security Sheet. Linings as in table.

Detail	Partition thickness mm	Board type	Lining thickness mm	Maximum partition height <sup>1</sup> mm	Sound insulation $R_w$ dB	Duty rating	Approx. weight kg/m <sup>2</sup>	System reference
<b>30 minutes fire resistance</b> (EN)								
①	70	Glasroc F MULTIBOARD	2 x 10	3700 <sup>2</sup>	40	Severe	50	G100001
<b>120 minutes fire resistance</b> (EN)								
①	70	Glasroc F MULTIBOARD	2 x 10	3000	40	Severe	50	G100001

▶ For further assistance in choosing the right solution for your project, try our System Selector; an online tool that enables quick and easy filtering by performance criteria. It provides system specific information downloads including BIM (Revit) objects. Go to [gyproc.ie](http://gyproc.ie)

<sup>1</sup> The maximum heights quoted are limited by the fire state field of application or by limiting deflection of L/240 at 200 Pa, whichever is the more onerous.

<sup>2</sup> Maximum recommended height is 3000mm based on using single sheets of Gypframe Security Sheet with no horizontal overlap. Heights of 3700mm are achievable. Contact the Gyproc Technical Department for further guidance.

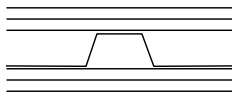
**(NB)** The fire resistance and sound insulation performances are for imperforate partitions, walls and ceilings incorporating boards with all joints taped and filled, or skimmed according to Gyproc's recommendations. The quoted performances are achieved only if Gyproc and Isover components are used throughout, and the Company's fixing recommendations are strictly observed. Any variation in the specification should be checked with Gyproc

For details of when to specify fire resistance using BS  
 ▶ Refer to C02. S01. P18



**Table 1b — Solutions to satisfy requirements of BS 476: Part 22: 1987**

①



Two layers of board each side of Gypframe Security Sheet. Linings as in table.

Detail	Partition thickness mm	Board type	Lining thickness mm	Maximum partition height <sup>1</sup> mm	Sound insulation $R_w$ dB	Duty rating	Approx. weight kg/m <sup>2</sup>	System reference
<b>150 minutes fire resistance</b> (BS)								
①	70	Glasroc F MULTIBOARD	2 x 10	3700 <sup>2</sup>	40	Severe	50	G100001

▶ For further assistance in choosing the right solution for your project, try our System Selector; an online tool that enables quick and easy filtering by performance criteria. It provides system specific information downloads including BIM (Revit) objects. Go to [gyproc.ie](http://gyproc.ie)

<sup>1</sup> The maximum height quoted is based on a limiting deflection of L/240 at 200 Pa.

<sup>2</sup> Maximum recommended height is 3000mm based on using single sheets of Gypframe Security Sheet with no horizontal overlap. Heights of 3700mm are achievable. Contact the Gyproc Technical Department for further guidance.

**(NB)** The fire resistance and sound insulation performances are for imperforate partitions, walls and ceilings incorporating boards with all joints taped and filled, or skimmed according to Gyproc's recommendations. The quoted performances are achieved only if Gyproc and Isover components are used throughout, and the Company's fixing recommendations are strictly observed. Any variation in the specification should be checked with Gyproc.

# GypWall **SECURE** design

## Security

The excellent mechanical properties of Glasroc F MULTIBOARD, combined with the stiffness and resilience of Gypframe Security Sheet, make GypWall **SECURE** a formidable barrier to entry. It has a high resistance to 'determined attack' using hand tools, and good resistance to attack using power tools.

Adhoc tests have been carried out at the Building Test Centre. A 'determined attack' by a team of four using hand tools did not achieve through-penetration for approximately 10 minutes. Where even greater resistance to attack is required, 0.7mm flat galvanised steel sheet (by others) should be fixed to the risk side of the security sheet prior to boarding.

## Planning - key factors

Vertical service runs can be accommodated within the profile of the security sheet.

## Head and base fixing

Gypframe GA4 Steel Angles are fixed to the structure at 300mm centres. Contact the Gyproc Technical Department for further guidance.

## Services

Services and penetrations should be avoided in this system.

## Fixtures

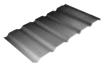
Lightweight fixtures can be made directly into Glasroc F MULTIBOARD. Medium weight fixtures can be made through the lining into the 'high points' of the security sheet core.

## Board finishing

► Refer to C08. S01. P483 – Finishes.

# GypWall SECURE system components

## Gypframe metal components



### Gypframe Security Sheet

Engineered to support the board in the cavity and to provide additional resistance to attack.



### Gypframe GA4 Steel Angle

Used to provide support to the Gypframe Security Sheet.

## Metal products (by others)

### Flat galvanised steel sheet (optional)

0.7mm thickness for additional resistance to attack.

## Board products



### Glasroc F MULTIBOARD

High performance, non combustible glass reinforced plasterboard. Also provides impact resistance.

## Fixing products



### Gyproc Wafer Head Jack-Point Screws

Fixing lapped Gyprame Security Sheet together, and to fix optional flat galvanised steel sheet to Gypframe Security Sheet.

### M8 Through bolt (by others)

M8 diameter bolt, for fixing Gypframe GA4 Steel Angles to structure.



### Gyproc Jack-Point Screws

Fixing boards to Gypframe Security Sheet.

## Plasterboard accessories



### Gyproc Jointing Materials

Jointing compounds, ready mixes and adhesives for reinforcement and finishing of board joints.



### Gyproc Paper Joint Tape

A paper tape designed for reinforcement of flat joints or internal angles.



### Gyproc Drywall Primer

Used to prepare for painting.  
Tub contents 10 litre.

## Finishing products



### Gyproc Skimcoat

To provide a plaster skim finish on most common backgrounds including undercoat plasters and plasterboard.



### Gyproc Carlite Finish

To provide a plaster skim finish on most common backgrounds including undercoat plasters and plasterboard.



### Gyproc Carlite Ultra Finish

Offers all the benefits of Gyproc Skimcoat and Gyproc Carlite Finish with a reduced set time of 90-120mins, making it ideal for smaller jobs.

# BlastWall

**BlastWall** offers resistance to explosive devices and can be specified in areas such as post rooms and blast refuge areas.



The system has been tested by Government departments. Specifications are determined on an individual basis following consultation with Gyproc and specialist blast design consultants as to the performance requirements.

For detailed information on the **BlastWall** system, please contact the Gyproc Technical Department.

## Key benefits

- Lightweight alternative to traditional constructions
- Highly resistant to explosions
- Shatter-resistant Glasroc F MULTIBOARD linings reduce the risk of injury from flying shards
- Beyond BS 5234 requirements
  - ▶ Refer to C02. S01. P37 - Robustness





# C06

## Floors and ceilings

## Floors and ceilings

This section details floors and ceilings systems which cover a multitude of performance requirements in all sectors





## Floors and ceilings

Gyproc offers a full range of specifications from simple plasterboard ceilings through to a range of gypsum-based, acoustic suspended ceilings and lay-in grid systems. They cover all building categories, including private and social housing, apartments, healthcare, educational facilities, recreational and industrial properties in both new-build and refurbishment and can satisfy the most demanding performance requirements.

When specifying floor and ceiling solutions, a number of performance characteristics are normally used to determine the required solution. Depending on the project or construction type, these performance parameters could be set by minimum regulatory standards, or a client or customer requirement, for buildings that offer the highest standards of performance and comfort.

Our quick-reference floors and ceilings system guide, below, allows you to simply select the performance categories of interest and identify the Gyproc floor and ceiling systems which best satisfy your project requirements.

 Fire performance mins	Installed cavity depth mm	 Acoustic performance				System	Page
		$R_w$ dB	$R_w + C_{tr}$ dB	$L_{n,w}$ dB	$\alpha_w$		
30 - 120	≥100	56 - 66	50 - 55	68 - 50	0.35 - 0.85	CasoLine MF	C06. S02. P355
30 - 90	25 - 175	52 - 63	50	66 - 55	0.35 - 0.85	GypLyner	C06. S06. P401
30 - 90	-	54 - 63	47 - 51	63 - 55	-	GypFloor SILENT <sup>1</sup>	C06. S07. P415
30 - 120	-	36 - 66	50 - 55	78 - 48	-	Timber floors	C06. S08. P427
30 - 60	-	-	-	-	-	Cavity fire barriers	C06. S09. P447

<sup>1</sup> Where the floor can only be accessed from above, the fire and acoustic performances can be upgraded with the GypFloor SILENT system.

<sup>2</sup> Indicative first test performance only.

## Acoustic performance

### Good practice specification guidance

Gyproc's systems are designed and tested to meet every performance requirement.

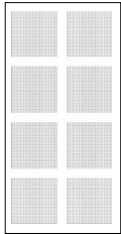
This means that when our systems are installed following our guidance they will achieve every performance claim we make, and if they don't then we'll put it right. To maximise the performance achieved on site, consider the following good practice specification guidance:

- Consider flanking transmission at the design stage and ensure construction detailing is specified to eliminate, or at least to minimise, any downgrading of the acoustic performance. The sound insulation values quoted in system performance tables are laboratory values and the practicalities of construction will mean that acoustic performances measured in the laboratory will be difficult to achieve on site
- Small openings such as gaps, cracks or holes will conduct airborne sounds and can significantly reduce the sound insulation of a construction. For optimum sound insulation a construction must be airtight
- When designing spaces requiring separation by sound insulating floors and ceilings abutting structural steelwork, consideration should be given to the potential loss of sound insulation performance through the steelwork
- We therefore recommend that design performance levels for Airborne sound are approximately 10dB higher and Impact sound performances are 5-10dB lower than the desired site test result

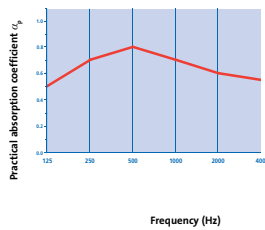


Table 1 – Sound absorption data for Gyptone boards

## QUATTRO 41



Sound absorption coefficient  $\alpha_p$



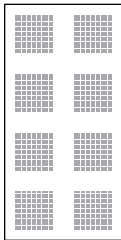
System reference ■ C10A091

■ Gyptone QUATTRO 41 (plenum depth 187mm)

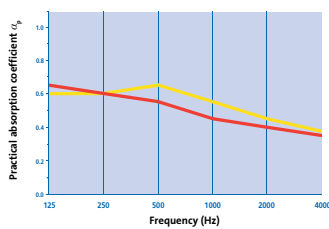
Practical absorption coefficient  $\alpha_p$

125	250	500	1k	2k	4k	$\alpha_w$	AC <sup>1</sup>	NRC <sup>2</sup>
0.50	0.70	0.80	0.70	0.60	0.55	<b>0.65</b>	<b>C</b>	<b>0.70</b>

## QUATTRO 46



Sound absorption coefficient  $\alpha_p$



System reference ■ C10A014  
■ C10A015

■ Gyptone QUATTRO 46 (plenum depth 400mm)  
■ Gyptone QUATTRO 46 (plenum depth 400mm plus 100mm Isover Spacesaver Ready-Cut)

Practical absorption coefficient  $\alpha_p$

125	250	500	1k	2k	4k	$\alpha_w$	AC <sup>1</sup>	NRC <sup>2</sup>
0.65	0.60	0.55	0.45	0.40	0.35	<b>0.45(L)</b>	<b>D</b>	<b>0.50</b>
0.60	0.60	0.65	0.55	0.45	0.40	<b>0.50(L)</b>	<b>D</b>	<b>0.55</b>

<sup>1</sup> AC - Absorption Class.

<sup>2</sup> NRC - Noise Reduction Coefficient.

<sup>3</sup> Due to installation limitations the minimum cavity size that can be constructed with CasoLine mf system is 100mm. The sound absorption performance for these systems is estimated to be equivalent to that of the same system built with a 50mm plenum.

**NB** All products have been tested to BS EN 20354 and ISO 354. The single figure rating practical sound absorption coefficient  $\alpha_w$  is calculated in accordance with EN ISO 11654. Suffix letters indicate where performance is limited at either low, medium or high frequencies.

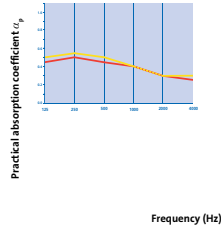
## Gyptone performance (continued)

Table 1 (continued) – Sound absorption data for Gyptone boards

### QUATTRO 47



#### Sound absorption coefficient $\alpha_p$



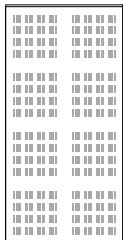
System reference ■ C10A016  
■ C10A017

- Gyptone **QUATTRO 47** (plenum depth 400mm)
- Gyptone **QUATTRO 47** (plenum depth 400mm plus 50mm Isover Roll)

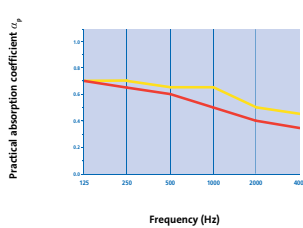
#### Practical absorption coefficient $\alpha_p$

	125	250	500	1k	2k	4k	$\alpha_w$	AC <sup>1</sup>	NRC <sup>2</sup>
<span style="color: red;">■</span>	0.45	0.50	0.45	0.40	0.30	0.25	<b>0.35(L)</b>	D	<b>0.40</b>
<span style="color: yellow;">■</span>	0.50	0.55	0.50	0.40	0.30	0.30	<b>0.40(L)</b>	D	<b>0.45</b>

### LINE 6



#### Sound absorption coefficient $\alpha_p$



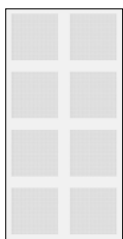
System reference ■ C10A001  
■ C10A002

- Gyptone **LINE 6** (plenum depth 400mm)
- Gyptone **LINE 6** (plenum depth 400mm plus 100mm Isover Spacesaver Ready-Cut)

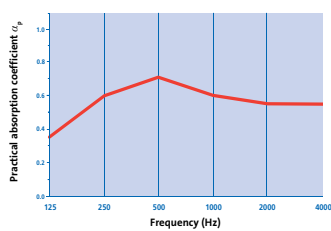
#### Practical absorption coefficient $\alpha_p$

	125	250	500	1k	2k	4k	$\alpha_w$	AC <sup>1</sup>	NRC <sup>2</sup>
<span style="color: red;">■</span>	0.70	0.65	0.60	0.50	0.40	0.35	<b>0.45(L)</b>	D	<b>0.55</b>
<span style="color: yellow;">■</span>	0.70	0.70	0.65	0.65	0.50	0.45	<b>0.55(L)</b>	D	<b>0.65</b>

### SIXTO 63



#### Sound absorption coefficient $\alpha_p$



System reference ■ C10A115

- Gyptone **SIXTO 63** (plenum depth 200mm)

#### Practical absorption coefficient $\alpha_p$

	125	250	500	1k	2k	4k	$\alpha_w$	AC <sup>1</sup>	NRC <sup>2</sup>
<span style="color: red;">■</span>	0.35	0.60	0.70	0.60	0.55	0.55	<b>0.60</b>	C	<b>0.60</b>

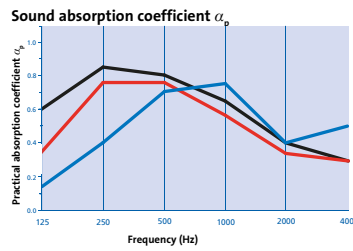
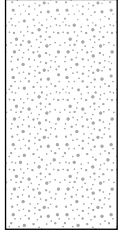
<sup>1</sup> AC - Absorption Class.

<sup>2</sup> NRC - Noise Reduction Coefficient.

**(NB)** All products have been tested to *BS EN 20354* and *ISO 354*. The single figure rating practical sound absorption coefficient  $\alpha_w$  is calculated in accordance with *EN ISO 11654*. Suffix letters indicate where performance is limited at either low, medium or high frequencies.

Table 2 – Sound absorption data for Rigitone boards

## 8-15-20 SUPER



System reference

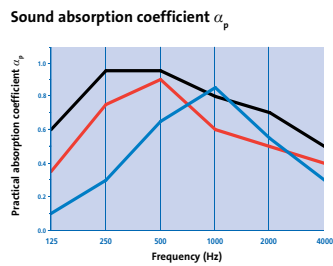
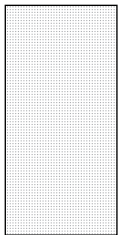
- C10A058
- C10A059
- C10A069

- Rigitone 8-15-20 SUPER (plenum depth 50mm)<sup>3</sup>
- Rigitone 8-15-20 SUPER (plenum depth 200mm)
- Rigitone 8-15-20 SUPER (plenum depth 200mm plus 50mm Isover Frame Batt 32)

### Practical absorption coefficient $\alpha_p$

	125	250	500	1k	2k	4k	$\alpha_w$	AC <sup>1</sup>	NRC <sup>2</sup>
<span style="color: blue;">■</span>	0.15	0.40	0.70	0.75	0.45	0.40	<b>0.50(M)</b>	D	<b>0.55</b>
<span style="color: red;">■</span>	0.35	0.75	0.75	0.55	0.40	0.30	<b>0.45(LM)</b>	D	<b>0.60</b>
<span style="color: black;">■</span>	0.60	0.85	0.80	0.65	0.45	0.30	<b>0.45(LM)</b>	D	<b>0.70</b>

## 8/18



System reference

- C10A036
- C10A037
- C10A060

- Rigitone 8/18 (plenum depth 50mm)<sup>3</sup>
- Rigitone 8/18 (plenum depth 200mm)
- Rigitone 8/18 (plenum depth 200mm plus 50mm Isover Frame Batt 32)

### Practical absorption coefficient $\alpha_p$

	125	250	500	1k	2k	4k	$\alpha_w$	AC <sup>1</sup>	NRC <sup>2</sup>
<span style="color: blue;">■</span>	0.10	0.30	0.65	0.85	0.55	0.30	<b>0.50(M)</b>	D	<b>0.55</b>
<span style="color: red;">■</span>	0.35	0.75	0.90	0.60	0.50	0.40	<b>0.55(LM)</b>	D	<b>0.70</b>
<span style="color: black;">■</span>	0.60	0.95	0.95	0.80	0.70	0.50	<b>0.70(LM)</b>	C	<b>0.85</b>

<sup>1</sup> AC - Absorption Class.

<sup>2</sup> NRC - Noise Reduction Coefficient.

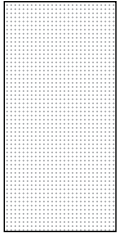
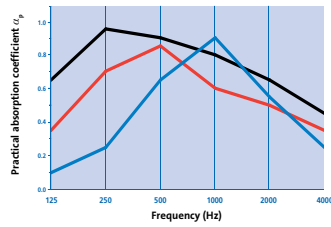
<sup>3</sup> Due to installation limitations the minimum cavity size that can be constructed with **CasoLine MF** system is 100mm. The sound absorption performance for these systems is estimated to be equivalent to that of the same system built with a 50mm plenum.

**(NB)** All products have been tested to *BS EN 20354* and *ISO 354*. The single figure rating practical sound absorption coefficient  $\alpha_w$  is calculated in accordance with *EN ISO 11654*. Suffix letters indicate where performance is limited at either low, medium or high frequencies.

## Rigitone performance (continued)

Table 2 (continued) - Sound absorption data for Rigitone boards

## 10/23

Sound absorption coefficient  $\alpha_p$ 

System reference

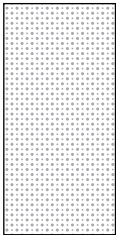
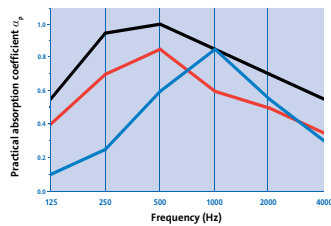
- C10A038
- C10A039
- C10A061

- Rigitone 10/23 (plenum depth 50mm)<sup>3</sup>
- Rigitone 10/23 (plenum depth 200mm)
- Rigitone 10/23 (plenum depth 200mm plus 50mm Isover Frame Batt 32)

Practical absorption coefficient  $\alpha_p$ 

125	250	500	1k	2k	4k	$\alpha_w$	AC <sup>1</sup>	NRC <sup>2</sup>
0.10	0.25	0.65	0.90	0.55	0.25	<b>0.45(M)</b>	<b>D</b>	<b>0.60</b>
0.35	0.70	0.85	0.60	0.50	0.35	<b>0.50(LM)</b>	<b>D</b>	<b>0.65</b>
0.65	0.95	0.90	0.80	0.65	0.45	<b>0.65(LM)</b>	<b>C</b>	<b>0.80</b>

## 12-20/66

Sound absorption coefficient  $\alpha_p$ 

System reference

- C10A042
- C10A043
- C10A063

- Rigitone 12-20/66 (plenum depth 50mm)<sup>3</sup>
- Rigitone 12-20/66 (plenum depth 200mm)
- Rigitone 12-20/66 (plenum depth 200mm plus 50mm Isover Frame Batt 32)

Practical absorption coefficient  $\alpha_p$ 

125	250	500	1k	2k	4k	$\alpha_w$	AC <sup>1</sup>	NRC <sup>2</sup>
0.10	0.25	0.60	0.85	0.55	0.30	<b>0.45(M)</b>	<b>D</b>	<b>0.55</b>
0.40	0.70	0.85	0.60	0.50	0.35	<b>0.50(LM)</b>	<b>D</b>	<b>0.65</b>
0.55	0.95	1.00	0.85	0.70	0.55	<b>0.70(LM)</b>	<b>C</b>	<b>0.90</b>

<sup>1</sup> AC – Absorption Class.

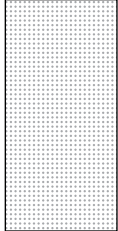
<sup>2</sup> NRC – Noise Reduction Coefficient.

<sup>3</sup> Due to installation limitations the minimum cavity size that can be constructed with CasoLine mf system is 100mm. The sound absorption performance for these systems is estimated to be equivalent to that of the same system built with a 50mm plenum.

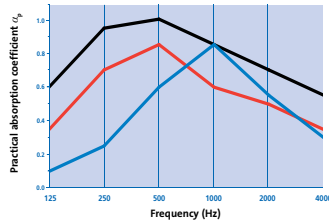
**(NB)** All products have been tested to BS EN 20354 and ISO 354. The single figure rating practical sound absorption coefficient  $\alpha_w$  is calculated in accordance with EN ISO 11654. Suffix letters indicate where performance is limited at either low, medium or high frequencies.

Table 2 (continued) – Sound absorption data for Rigitone boards

15/30



Sound absorption coefficient  $\alpha_p$



System reference

- C10A040
- C10A041
- C10A062

- Rigitone 15/30 (plenum depth 50mm)<sup>3</sup>
- Rigitone 15/30 (plenum depth 200mm)
- Rigitone 15/30 (plenum depth 200mm plus 50mm Isover Frame Batt 32)

Practical absorption coefficient  $\alpha_w$

	125	250	500	1k	2k	4k	$\alpha_w$	AC <sup>1</sup>	NRC <sup>2</sup>
<span style="color: blue;">■</span>	0.10	0.25	0.60	0.85	0.55	0.30	<b>0.45(M)</b>	D	<b>0.55</b>
<span style="color: red;">■</span>	0.35	0.70	0.85	0.60	0.50	0.35	<b>0.50(LM)</b>	D	<b>0.65</b>
<span style="color: black;">■</span>	0.60	0.95	1.00	0.85	0.70	0.55	<b>0.70(LM)</b>	C	<b>0.85</b>

<sup>1</sup> AC – Absorption Class.

<sup>2</sup> NRC – Noise Reduction Coefficient.

<sup>3</sup> Due to installation limitations the minimum cavity size that can be constructed with CasoLine MF system is 100mm. The sound absorption performance for these systems is estimated to be equivalent to that of the same system built with a 50mm plenum.

**(NB)** All products have been tested to BS EN 20354 and ISO 354. The single figure rating practical sound absorption coefficient  $\alpha_w$  is calculated in accordance with EN ISO 11654. Suffix letters indicate where performance is limited at either low, medium or high frequencies.

# Casoline MF

Concealed monolithic metal frame suspended ceiling system



## Casoline MF

**Casoline MF** is a suspended ceiling system suitable for most internal drylining applications. The fully concealed grid and ceiling lining can be used in conjunction with Gyproc plasterboards and Gyptone and Rigitone acoustic ceiling boards to create a seamless, monolithic appearance.

### Key benefits

- High level of design flexibility; bulkheads, gradients and changes in height can all be fully integrated
- Services inspection and access points are easily included during design or installation
- Adaptable metal framing system fully compatible with a wide range of Gyproc lining solutions to achieve a variety of performances tailored to meet individual project requirements
- Improvement to acoustic and fire performance can be achieved without the need to access the room above
- Partition heights can be reduced as the partition channel can be supported by the ceiling framework rather than the soffit

30 – 120 mins

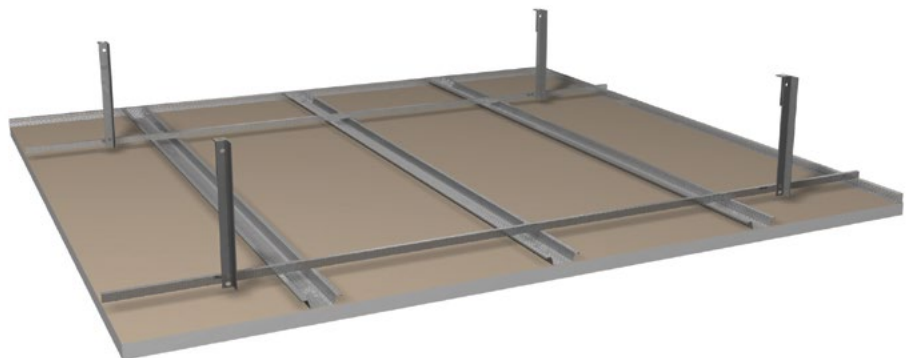
0.35 – 0.85  $\alpha_w$

56 – 66  $R_w$  dB

68 – 50  $L_{E,w}$  dB

SpecSure®

Refer to C01. S01. P08



### You may also be interested in...

#### ShaftWall

To achieve up to a full 120 minutes fire resistance to a ceiling void.

► Refer to C05. S02. P298 – horizontal ShaftWall.

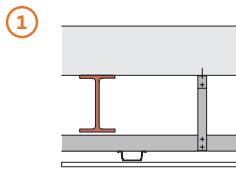
# CasoLine MF performance

## Fire protection to steel beams supporting concrete floors<sup>1</sup>

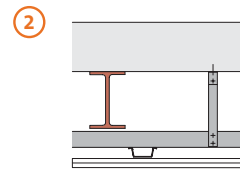
For details of when to specify fire resistance using BS  
 ▶ Refer to C02. S01. P18



Table 1 – Solutions to satisfy requirements of BS 476: Part 23: 1987



1 CasoLine MF ceiling suspended beneath steel beams supporting a concrete floor. Ceiling linings as in table.



2 CasoLine MF ceiling suspended beneath steel beams supporting a concrete floor. Ceiling linings as in table.

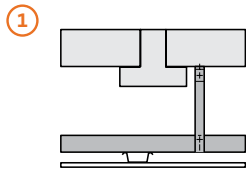
Detail	Board type	Ceiling lining thickness mm	Approx. weight kg/m <sup>2</sup>	MF5 support centres mm	MF7 support centres mm	System reference
<b>30 minutes fire resistance</b> BS						
2	Gyproc WallBoard	2 x 12.5	18	450	1200	C100013
<b>60 minutes fire resistance</b> BS						
1	Gyproc FireLine	1 x 12.5	11	450	1200	C100014
1	Glasroc F MULTIBOARD	1 x 12.5	12	600	1200	G100036
<b>120 minutes fire resistance</b> BS						
2	Glasroc F MULTIBOARD	2 x 10	20	400	1200	G100038
2	Gyproc FireLine	2 x 15	25	400	900	C100015

▶ For further assistance in choosing the right solution for your project, try our System Selector; an online tool that enables quick and easy filtering by performance criteria. It provides system specific information downloads including BIM (Revit) objects. Go to [gyproc.ie](http://gyproc.ie)

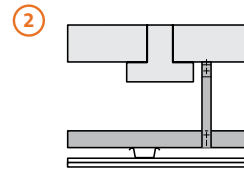
<sup>1</sup> Concrete floors as described in BS 476: Part 23: 1987. The steel beams subjected to test had a section factor A/V (Hp/A) of 205m<sup>-1</sup> calculated on the basis of three sided profiled exposure. The suspended ceiling will also provide adequate protection to steel beams with a lower section factor.

## Sound insulation

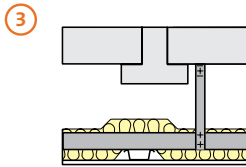
Table 2 – CasoLine MF upgrading the sound insulation of concrete floors<sup>1</sup>



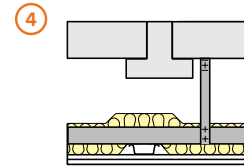
① CasoLine MF ceiling suspended beneath basic floor to give 240mm cavity. Ceiling linings as in table.



② CasoLine MF ceiling suspended beneath basic floor to give 240mm cavity. Ceiling linings as in table.



③ CasoLine MF ceiling suspended beneath basic floor to give 240mm cavity, with 100mm Isover Spacesaver Ready-Cut in cavity. Ceiling linings as in table.



④ CasoLine MF ceiling suspended beneath basic floor to give 240mm cavity, with 100mm Isover Spacesaver Ready-Cut in cavity. Ceiling linings as in table.

Detail	Board type	Ceiling lining thickness mm	Approx. weight kg/m <sup>2</sup>	Sound insulation		System reference
				Airborne $R_w (R_w + C_{tr})$ dB	Impact $L_{n,w}$ dB	
①	Gyproc WallBoard	1 x 12.5	9	56 (50)	68	C100016
②	Gyproc FireLine	2 x 12.5	21	58 (51)	66	C100017
③	Gyproc SoundBloc	1 x 12.5	12	61 (51)	60	C100018
④	Gyproc SoundBloc	2 x 12.5	23	64 (55) <sup>2</sup>	57	C100019

► For further assistance in choosing the right solution for your project, try our System Selector; an online tool that enables quick and easy filtering by performance criteria. It provides system specific information downloads including BIM (Revit) objects. Go to [gyproc.ie](http://gyproc.ie)

<sup>1</sup> Basic floor construction is lightweight concrete joist floor with insulated concrete infill panel (surface density of infill is 90kg/m<sup>2</sup>) and total depth 150mm. Sound insulation is  $R_w$  35dB (airborne) and  $L_{n,w}$  91dB (impact).

<sup>2</sup> This Gyproc Approved System is designed to achieve minimum  $D_{nT,w} + C_{tr}$  45dB and  $L'_{nT,w}$  62dB subject to Pre-Completion Testing.

**NB** The fire resistance and sound insulation performances are for imperforate partitions, walls and ceilings incorporating boards with all joints taped and filled, or skimmed according to Gyproc's recommendations. The quoted performance (from the underside to the ceiling plenum only) are achieved only if Gyproc and Isover components are used throughout, and the Company's fixing recommendations are strictly observed. Any variation in the specification should be checked with Gyproc.

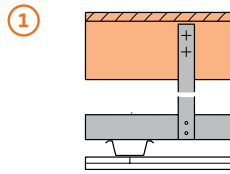
## Casoline MF performance (continued)

### Fire protection to timber floor construction

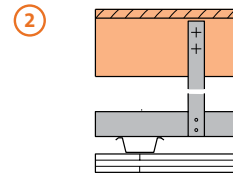
For details of when to specify fire resistance using EN  
 ▶ Refer to C02. S01. P18



Table 3a – Solutions to satisfy requirements of BS EN 1365-2: 2000



① Floor boarding of 21mm minimum t&g softwood or wood particle floor boarding. Solid timber joists 38 x 195mm at 600mm centres. Casoline MF suspended ceiling fixed to joists. Ceiling linings as in table.



② Floor boarding of 21mm minimum t&g softwood or wood particle floor boarding. Solid timber joists 38 x 195mm at 600mm centres. Casoline MF suspended ceiling fixed to joists. Ceiling linings as in table.

Detail	Board type	Ceiling lining thickness mm	Approx. weight kg/m <sup>2</sup>	MF5 support centres mm	MF7 support centres mm	System reference
<b>60 minutes fire resistance</b> (EN)						
①	Gyproc FireLine	2 x 12.5	21	450	1200	C106003
<b>90 minutes fire resistance</b> (EN)						
②	Glasroc F MULTIBOARD	3 x 10	30 <sup>1</sup>	450	1200 <sup>1</sup>	G106035

▶ For further assistance in choosing the right solution for your project, try our System Selector; an online tool that enables quick and easy filtering by performance criteria. It provides system specific information downloads including BIM (Revit) objects. Go to [gyproc.ie](http://gyproc.ie)

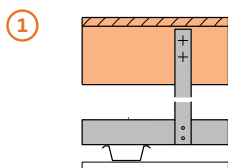
<sup>1</sup>This system is close to its maximum allocation weight. Refer to table 6 for solutions to increase the maximum recommended load.

**(NB)** The fire resistance and sound insulation performances are for imperforate partitions, walls and ceilings incorporating boards with all joints taped and filled, or skimmed according to Gyproc's recommendations. The quoted performance (from the underside to the ceiling plenum only) are achieved only if Gyproc and Isover components are used throughout, and the Company's fixing recommendations are strictly observed. Any variation in the specification should be checked with Gyproc.

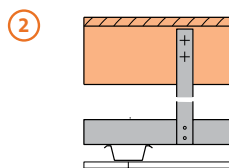
**(NB)** The maximum substantiated span on the above solid timber joist systems is 4000mm. For any spans greater than this please contact our Technical Department.



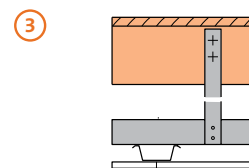
Table 3b – Solutions to satisfy the requirements of BS 476: Part 21: 1987



1 Floor boarding of 21mm minimum t&g softwood or wood particle floor boarding. Solid timber joists 38 x 195mm at 600mm centres. CasoLine MF suspended ceiling fixed to joists. Ceiling linings as in table.



2 Floor boarding of 21mm minimum t&g softwood or wood particle floor boarding. Solid timber joists 38 x 195mm at 600mm centres. CasoLine MF suspended ceiling fixed to joists. Ceiling linings as in table.



3 Floor boarding of 21mm minimum t&g softwood or wood particle floor boarding. Solid timber joists 38 x 195mm at 600mm centres. CasoLine MF suspended ceiling fixed to joists. Ceiling linings as in table.

Detail	Joist size mm	Board type	Ceiling lining thickness mm	Approx. weight kg/m <sup>2</sup>	MF5 support centres mm	MF7 support centres mm	System reference
<b>30 minutes fire resistance BS</b>							
1	38 x 225	Gyproc FireLine	1 x 12.5	11	450	1200	C106001
2	38 x 225	Gyproc WallBoard	2 x 12.5	18	450	1200	C106002
<b>60 minutes fire resistance BS</b>							
2	38 x 195	Gyproc FireLine	2 x 12.5	21	450	1200	C106003
<b>90 minutes fire resistance BS</b>							
2	38 x 175	Gyproc FireLine	2 x 15	25	450	900	C106004
<b>120 minutes fire resistance BS</b>							
3	38 x 175	Glasroc F MULTIBOARD	3 x 10	30 <sup>1</sup>	450	1200 <sup>1</sup>	G106035

▶ For further assistance in choosing the right solution for your project, try our System Selector; an online tool that enables quick and easy filtering by performance criteria. It provides system specific information downloads including BIM (Revit) objects. Go to [gyproc.ie](http://gyproc.ie)

<sup>1</sup> This system is close to its maximum weight. Refer to table 6 for solutions to increase the maximum recommended load.

**NB** The fire resistance and sound insulation performances are for imperforate partitions, walls and ceilings incorporating boards with all joints taped and filled, or skimmed according to Gyproc's recommendations. The quoted performance (from the underside to the ceiling plenum only) are achieved only if Gyproc and Isover components are used throughout, and the Company's fixing recommendations are strictly observed. Any variation in the specification should be checked with Gyproc.

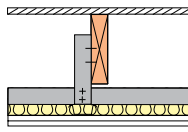
**NB** For non t&g floors, overlay with 6mm plywood and ensure all joints are staggered.

For details of when to specify fire resistance using BS/EN  
 ▶ Refer to C02. S01. P18



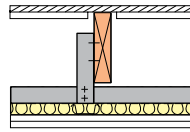
Table 4 – Solutions to satisfy requirements of EN 1365-2: 2000 (where applicable) and BS 476: Part 21: 1987

①



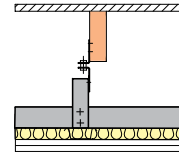
Casoline MF ceiling suspended beneath basic floor (ceiling removed) to give 277mm cavity. 100mm Isover Spacesaver Ready-Cut laid on ceiling boards. Ceiling linings as in table.

②



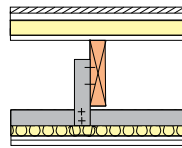
Casoline MF ceiling suspended beneath basic floor (ceiling removed) with a layer of Gyproc Plank fixed to the underside of the chipboard to give a 258mm cavity. 100mm Isover Spacesaver Ready-Cut laid on ceiling boards. Ceiling linings as in table.

③



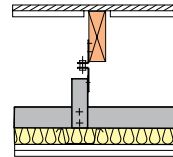
Casoline MF ceiling suspended beneath basic floor (ceiling removed) using Gyproframe Acoustic Hangers to give 277mm cavity. 100mm Isover Spacesaver Ready-Cut laid on ceiling boards. Ceiling linings as in table.

④



New floating floor<sup>2</sup> laid over joists. Casoline MF ceiling suspended beneath 195mm x 45mm timber joists at 600mm centres to give 277mm cavity. 100mm Isover Spacesaver Ready-Cut laid on ceiling boards. Ceiling linings as in table.

⑤



Casoline MF ceiling suspended beneath GypFloor SILENT using Gyproframe Acoustic Hangers to give 277mm cavity. 100mm Isover Spacesaver Ready-Cut laid on ceiling boards. Ceiling linings as in table.

Detail <sup>1</sup>	Board type	Ceiling lining thickness mm	Approx. weight kg/m <sup>2</sup>	Floor depth mm	Sound insulation		System reference
					Airborne R <sub>w</sub> (R <sub>w</sub> + C <sub>tr</sub> ) dB	Impact L <sub>n,w</sub> dB	
<b>30 minutes fire resistance</b> (BS)							
①	Gyproc SoundBloc	2 x 12.5	23	320	60	60	C106007
②	Gyproc SoundBloc	2 x 12.5	23	320	63 (51)	57	C106009
③	Gyproc SoundBloc	2 x 12.5	23	320	63 (55) <sup>4</sup>	54	C106013
④	Gyproc SoundBloc	2 x 12.5	23	376	66 (54) <sup>4</sup>	50	C106011
<b>60 minutes fire resistance</b> (EN) (BS)							
①	Gyproc SoundBloc	2 x 15	27	325	60	60	C106014
③	Gyproc FireLine	2 x 12.5	21	320	62 (53) <sup>4</sup>	55	C106022
③	Gyproc SoundBloc	2 x 15	27	325	63 (55) <sup>4</sup>	54	C106023
④	Gyproc SoundBloc	2 x 15	27	381	66 (54) <sup>4</sup>	50	C106025
⑤	Gyproc SoundBloc	2 x 15	27	336	63 (55) <sup>4</sup>	51	C106026
<b>90 minutes fire resistance</b> (BS)							
①	Gyproc FireLine	2 x 15 <sup>3</sup>	25	325	59	61	C106004
③	Gyproc FireLine	2 x 15 <sup>3</sup>	25	325	62 (53) <sup>4</sup>	55	C106024

▶ For further assistance in choosing the right solution for your project, try our System Selector; an online tool that enables quick and easy filtering by performance criteria. It provides system specific information downloads including BIM (Revit) objects. Go to [gyproc.ie](http://gyproc.ie)

<sup>1</sup> Basic floor construction is 45mm x 195mm timber joists at 600mm centres with 21mm t&g wood chipboard flooring.

<sup>2</sup> 18mm t&g wood chipboard spot bonded to Gyproc Plank on Isover Sound Deadening Floor Slab laid on overlining of 12mm plywood.

<sup>3</sup> Gyproframe MF7 Primary Support Channel at 900mm centres.

<sup>4</sup> These Gyproc Approved Systems are designed to achieve minimum D<sub>nT,w</sub> + C<sub>tr</sub> 45dB and L<sub>nT,w</sub> 62dB subject to Pre-Completion Testing.

**(NB)** The fire resistance and sound insulation performances are for imperforate partitions, walls and ceilings incorporating boards with all joints taped and filled, or skimmed according to Gyproc's recommendations. The quoted performance (from the underside to the ceiling plenum only) are achieved only if Gyproc and Isover components are used throughout, and the Company's fixing recommendations are strictly observed. Any variation in the specification should be checked with Gyproc.

**(NB)** The maximum substantiated span on the above solid timber joist systems is 4000mm. For any spans greater than this please contact our Technical Department.

## CasoLine MF performance (continued)

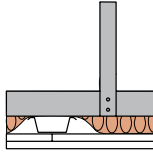
### Fire protection to floor or roof cavity above suspended ceiling<sup>1</sup>

For details of when to specify fire resistance using EN  
 ▶ Refer to C02. S01. P18



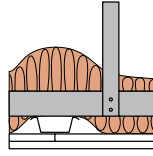
Table 5a – Solutions to satisfy requirements of EN 1364-2: 1999

①



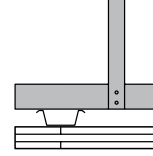
**CasoLine MF** suspended ceiling fixed to structure.  
 25mm stone mineral wool slabs (100kg/m<sup>3</sup>)  
 laid over Gyproframe MF5 Ceiling Section.  
 Ceiling linings as in table.

②



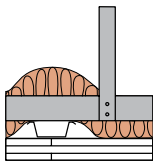
**CasoLine MF** suspended ceiling fixed to structure.  
 150mm stone mineral wool roll (24kg/m<sup>3</sup>)  
 laid over Gyproframe MF5 Ceiling Section.  
 Ceiling linings as in table.

③



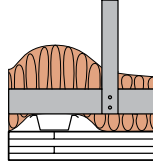
**CasoLine MF** suspended ceiling fixed to structure.  
 Ceiling linings as in table.

④



**CasoLine MF** suspended ceiling fixed to structure.  
 100mm stone mineral wool roll (24kg/m<sup>3</sup>)  
 laid over Gyproframe MF5 Ceiling Section.  
 Ceiling linings as in table.

⑤



**CasoLine MF** suspended ceiling fixed to structure.  
 150mm stone mineral wool roll (24kg/m<sup>3</sup>)  
 laid over Gyproframe MF5 Ceiling Section.  
 Ceiling linings as in table.

Detail	Board type	Ceiling lining thickness mm	Approx. weight kg/m <sup>2</sup>	MF5 support centres mm	MF7 support centres mm	System reference
<b>30 minutes fire resistance</b> (EN)						
①	Gyproc FireLine	2 x 12.5	22	450	1200	C106046
<b>60 minutes fire resistance</b> (EN)						
①	Glasroc F FIRECASE	2 x 15	28 <sup>2</sup>	450	1200 <sup>2</sup>	G106040
②	Gyproc FireLine	2 x 15	36 <sup>2</sup>	400	1200 <sup>2</sup>	C106060
③	Gyproc FireLine	3 x 15	45	400	600	C106061
<b>90 minutes fire resistance</b> (EN)						
④	Gyproc FireLine	3 x 15	50	400	600	C106062
<b>120 minutes fire resistance</b> (EN)						
⑤	Gyproc FireLine	4 x 15 <sup>3</sup>	64 <sup>2</sup>	400	600 <sup>2</sup>	C100038
③	GLASROC F FIRECASE	3 x 15	40 <sup>2</sup>	400	900 <sup>2</sup>	G100042

▶ For further assistance in choosing the right solution for your project, try our System Selector; an online tool that enables quick and easy filtering by performance criteria. It provides system specific information downloads including BIM (Revit) objects. Go to [gyproc.ie](http://gyproc.ie)

<sup>1</sup> The requirement for providing cavity barriers in the same plane as fire-resistant walls may not apply to cavities in floors and roofs if the ceiling beneath the floor or roof cavity provides a minimum of a full 30 minutes fire resistance (30 mins integrity : 30 mins insulation) in addition to satisfying other requirements. Refer to C06. S06. P422 – Cavity fire barriers.

<sup>2</sup> This system is close to its maximum allocation weight. Refer to table 6 for solutions to increase the maximum recommended load.

<sup>3</sup> An additional Gyproframe GFS1 fixing strap is required behind the longitudinal joints of the outer layer of 15mm Gyproc FireLine with fixings through the plasterboard into the Gyproframe GFS1 at 200mm centres.

**(NB)** The fire resistance and sound insulation performances are for imperforate partitions, walls and ceilings incorporating boards with all joints taped and filled, or skimmed according to Gyproc's recommendations. The quoted performance (from the underside to the ceiling plenum only) are achieved only if Gyproc and Isover components are used throughout, and the Company's fixing recommendations are strictly observed. Any variation in the specification should be checked with Gyproc.

## Building design

CasoLine MF comprises Gypframe MF7 Primary Support Channels and Gypframe MF5 Ceiling Sections which forms a suspended frame to which Gyproc, Gyptone, Rigitone and Glasroc boards can be fixed.

## Planning – key factors

The depth of the ceiling cavity is a minimum 100mm.

## Cavity fire barriers

Where cavity fire barriers are required, these can be formed using Gyproc FireLine or Glasroc F MULTIBOARD screw-fixed to a simple frame. The framing should be fixed to the structure to avoid undue loading of the ceiling suspension grid or, alternatively, additional hangers should be incorporated to support the ceiling alongside the cavity fire barrier.

► Refer to C06. S06. P422 – Cavity fire barriers.

## Relative humidity

CasoLine MF ceilings lined with Gyproc, Gyptone, Rigitone or Gyproc Specialist Boards are suitable for use under normal occupancy conditions. Buildings in which they are used should be dry, glazed and enclosed, with environmental conditions of no greater than 70% RH at 10°C to 20°C. For high humidity / high moisture conditions use Gyproc plasterboard MF variants or Glasroc F MULTIBOARD.

► Refer to C02. S01. P39 – Robustness.

## Vapour control

Isover Vario membranes may be used to provide vapour control to ceilings.

## Acoustic performance

Gyptone and Rigitone boards are perforated and designed to provide sound absorption when used in conjunction with an airspace behind the ceiling. Increased levels of sound absorption can be achieved by including insulation over the back of the ceiling. Where sound insulation room-to-room is required, sound attenuation  $D_{n,c,w}$  of 39dB can be achieved by the inclusion of 100mm Isover Spacesaver Ready-Cut over the back of the ceiling. Alternatively, other design considerations should be adopted such as extending adjoining partitions into the plenum void or installing a plenum barrier.

► Refer to C06. S01. P349 – Floors and ceilings introduction, tables 1 and 2.

## Thermal performance

Isover insulation can be laid over the suspension grid to provide the required standard of thermal insulation. Contact the Gyproc Technical Department for further guidance.

## Ceiling lift

Changes to Building Regulations Approved Document L, airtightness requirements within dwellings, can lead to greater changes in air pressure when a door is opened. The ceiling is normally the lightest fixed element in the room, and therefore most likely to be affected by this change in pressure.

This can cause the ceiling to lift, which may create a noise. Whilst this noise can be annoying to the occupier, it has no detrimental effect on the performance of the ceiling.

The designer should consider incorporating a pressure release system to minimise the risk of ceiling lift. Where sufficient 'pressure relief' cannot be designed in, it is recommended that the Gypframe MF5 Ceiling Section and the Gypframe MF7 Primary Support Channel should be screw-fixed together using two Gyproc Wafer Head Jack-Point Screws at each intersection, particularly where non-perforated board linings are specified.

## Imposed loads

Tables 6, 7 and 8 provide loading data for the suspension grid for Gyproc, Glasroc specialist, Gyptone and Rigitone boards respectively. Maximum loads will be reduced by 25% when Gypframe FEA1 Steel Angle is fixed directly to the soffit (modified loads are shown in brackets).

**Table 6 – Maximum recommended loads on CasoLine MF with Gyproc or Glasroc specialist board linings**

Maximum load including weight of board, any insulation and finish plaster MF5 <sup>1</sup> at 450mm centres kg/m <sup>2</sup> (modified load)	Suspension point centres mm	MF7 <sup>2</sup> channel centres mm
60	1200	600
40	1200	900
35	900	1200
30 (23)	1200	1200

<sup>1</sup> Gypframe MF5 Ceiling Section.

<sup>2</sup> Gypframe MF7 Primary Support Channel.

**Table 7 – Maximum recommended loads on CasoLine MF with Gyproc<sup>3</sup> or Gyptone board linings**

Maximum load including weight of board, and any insulation MF5 <sup>1</sup> at 600mm centres kg/m <sup>2</sup> (modified load)	Suspension point centres mm	MF7 <sup>2</sup> channel centres mm
55	1200	600
35	1200	900
25 (19)	1200	1200

<sup>1</sup> Gypframe MF5 Ceiling Section.

<sup>2</sup> Gypframe MF7 Primary Support Channel.

<sup>3</sup> Only applies to ceilings that have no fire resistance or acoustic insulation performance and single layer 15mm board.

**Table 8 – Maximum recommended loads on CasoLine MF with Rigitone board linings**

Maximum load including weight of board, and any insulation MF5 <sup>1</sup> at 330mm centres kg/m <sup>2</sup> (modified load)	Suspension point centres mm	MF7 <sup>2</sup> channel centres mm
30 (23)	900	1000

<sup>1</sup> Gypframe MF5 Ceiling Section.

<sup>2</sup> Gypframe MF7 Primary Support Channel.

## Casoline MF design (continued)

### Suspension – Gyproc, Glasroc specialist and Gyptone board linings

Fixing points for suspending the metal grid are commonly required at 1200mm centres in each direction. Suitable fixing devices should be employed when fixing to the structure.

The ceiling grid can be suspended from a concrete soffit using Gypframe MF12 Soffit Cleats and Gypframe MF8 Strap Hanger, or alternatively, Gypframe FEA1 Steel Angle. The latter provides a more robust suspension support, which restricts any flexing of the lining when pressure is applied from below. Gypframe FEA1 Steel Angle is therefore the preferred suspension option when a plaster finish is specified to Gyproc boards. If Gypframe FEA1 Steel Angle is used, it is recommended that it is fixed to the soffit via Gypframe MF12 Soffit Cleats.

For single board solutions only, Gypframe FEA1 Steel Angle can be used to fix direct to the soffit. The angle should be cut along the spine with both flanges bent over. However, this will reduce the maximum loads that the grid is capable of supporting by 25%. Fixing Gypframe FEA1 Steel Angles direct is also not suitable if the ceiling is likely to deflect due to varying pressures and is not suitable for fixing to a sloping substrate.

Gypframe Acoustic Hangers can be used to suspend the grid from timber joists to maximise the degree of acoustic isolation. In a comparative test a 3dB improvement in airborne sound insulation and a 6dB improvement in impact sound insulation were achieved. Refer to table 4 and construction detail 7, relating to double layer 12.5mm Gyproc SoundBloc linings. With concrete floors the high mass of the construction means that high levels of acoustic performance can be achieved when the Casoline MF ceiling is suspended by conventional means, i.e. Gypframe MF8 Strap Hangers or Gypframe FEA1 Steel Angle.

### Suspension – Rigitone board linings

Gypframe MF7 Primary Support Channels are fixed at 1000mm centres. Fixing points to the structure for the Gypframe MF7 Primary Support Channels are required at 900mm centres. In addition to this, the Gypframe MF5 Ceiling Section should be installed at nominal 330mm centres.

▶ Refer to the **Gyproc Installation Guide** for full details.

### Partition to suspended ceiling junction

Where a GypWall metal stud partition is fixed to the framework of a Casoline MF ceiling, in accordance with Gyproc's installation instructions, its permissible maximum height is equal to that of where it is fixed direct to a structural soffit of the same height.



### Handy hint

When designing the Casoline MF ceiling grid with a partition fixed to the underside, consideration should be given to ensure MF sections run parallel to the position, providing suitable restraint. This may result in additional Gypframe MF5 Ceiling Sections being required.

In situations where a GypWall metal stud partition passes through a Casoline MF ceiling, which is to both sides of the partition and appropriately fixed to both this partition and perimeter partitions / walls, consideration can be given to the lateral restraint provided by the ceiling when developing the partition specification.

The relevant maximum height is the greater of the floor to Casoline MF ceiling or ceiling to structural soffit height. Care should be taken during installation of tall partitions so as to not adversely affect their performance. Contact the Gyproc Technical Department for further guidance.

### Services

The plenum can be used to route all service requirements including ducting, pipework, electrical cables and conduit. All services should be independently supported from the building structure. Where light weight light fittings, access panels and similar components are incorporated as part of the design requirements, consideration must be given to maintaining the integrity of the ceiling to meet fire resistance and sound insulation requirements.

▶ Refer to tables 6, 7 or 8 for maximum recommended loads.

▶ Refer to the Gyproc Technical Department for Gyproc Profilex Access Panels.

### Fixtures

Fixings to the system should always be made into the metal grid or to supplementary framing. Some adjustment of the primary grid may be required to support heavier fixtures, refer to tables 6, 7 and 8. Where loads outside this range are anticipated, independent suspension should be provided from the structure.

### Control joints

Gyproc Control Joints may be required in the ceiling to relieve stresses induced by expansion and contraction of the structure. It is recommended that they coincide with movement joints within the surrounding structure.

### Rigitone expansion joints

Rigitone boards should be cut 10mm short of the perimeter wall and should not be fixed to the perimeter channel.

▶ Refer to construction details 12 - 13.

### Board finishing

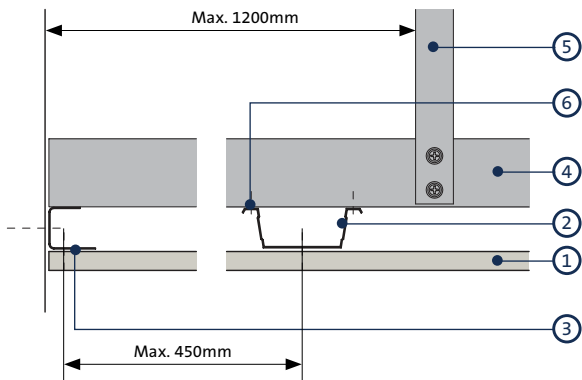
▶ Refer to C08. S01. P483 – Finishes.

Additional care and attention should be exercised when jointing Gyptone and Rigitone boards so as not to fill the perforations and impair the acoustic performance of the finished ceiling.

▶ Refer to the **Gyproc Installation Guide**.

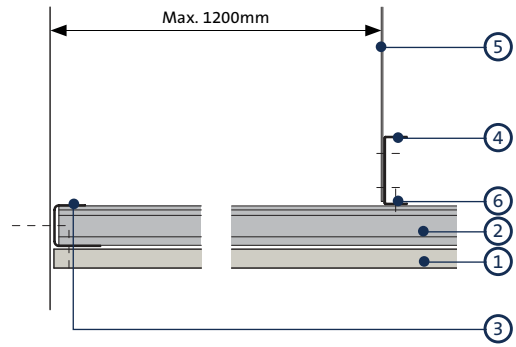
## Casoline MF construction details

1



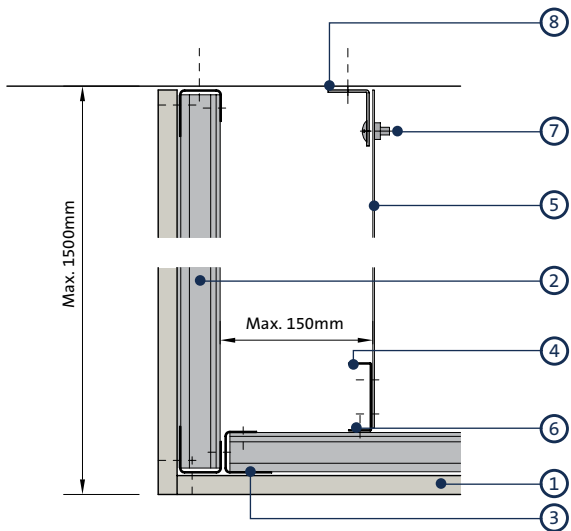
Perimeter parallel to Gypframe MF5 Ceiling Section  
- screw-fixed

2



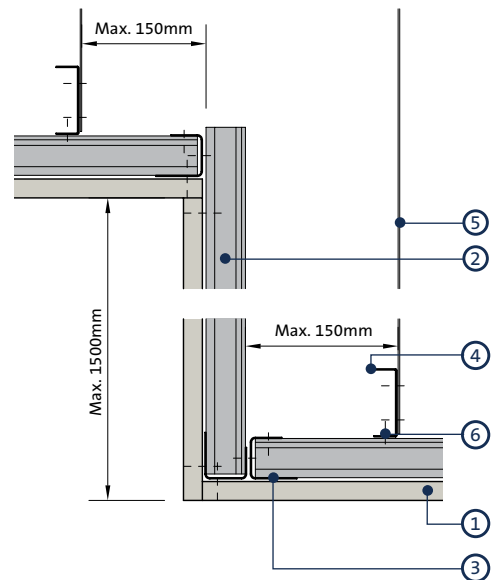
Perimeter perpendicular to Gypframe MF5 Ceiling Section  
- screw-fixed

3



Bulkhead - screw-fixed

4

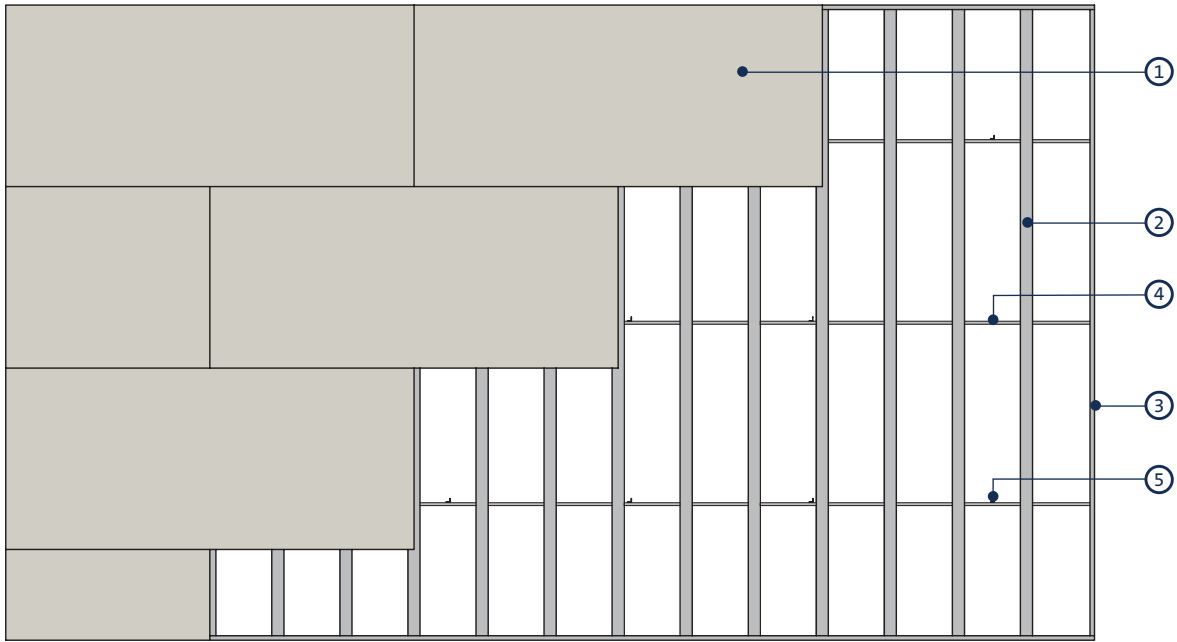


Change of level - screw-fixed

- 1 Gyproc plasterboard or Glasroc specialist board
- 2 Gypframe MF5 Ceiling Section
- 3 Gypframe MF6 Perimeter Channel
- 4 Gypframe MF7 Primary Support Channel

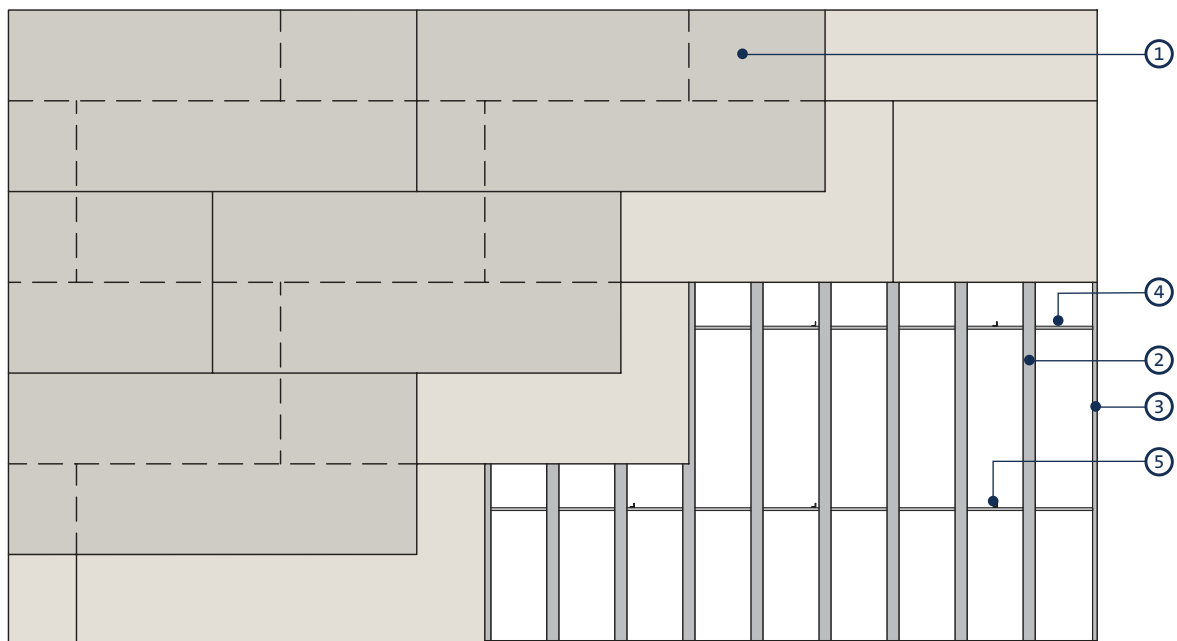
- 5 Gypframe MF8 Strap Hanger or Gypframe FEA1 Steel Angle
- 6 Gyproc Wafer Head Jack-Point Screw
- 7 Gypframe MF11 Nut and Bolt
- 8 Gypframe MF12 Soffit Cleat

5



Reflected ceiling plan - single layer

6



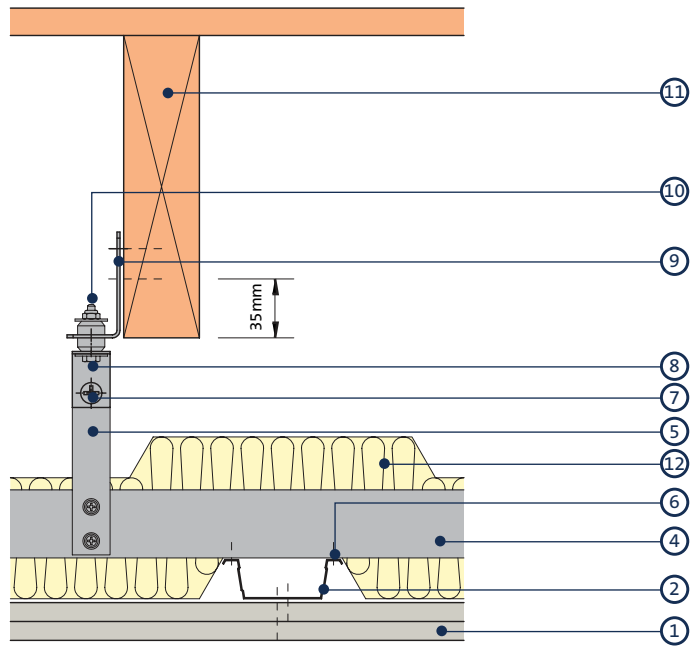
Reflected ceiling plan - double layer

- 1 Gyproc plasterboard or Glasroc specialist board
- 2 Gypframe MF5 Ceiling Section
- 3 Gypframe MF6 Perimeter Channel

- 4 Gypframe MF7 Primary Support Channel
- 5 Gypframe MF8 Strap Hanger or Gypframe FEA1 Steel Angle

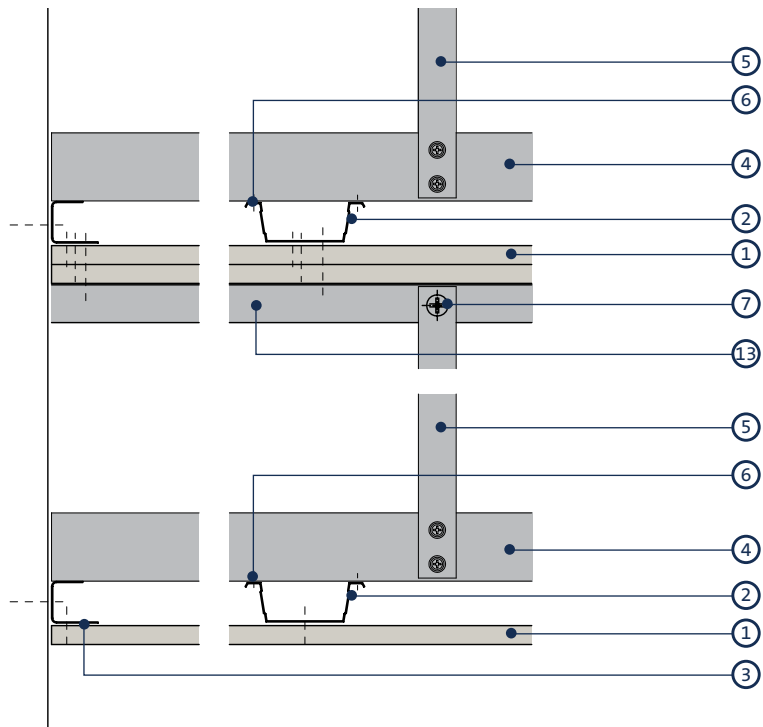
## Casoline MF construction details (continued)

7



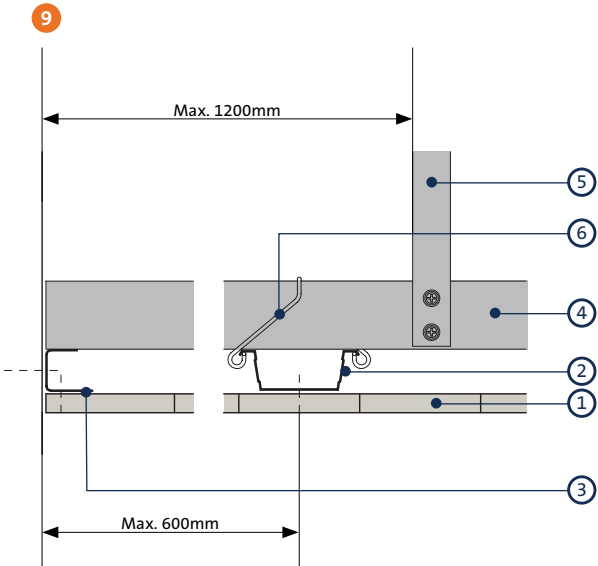
Suspension from timber joist using Gypframe Acoustic Hangers

8

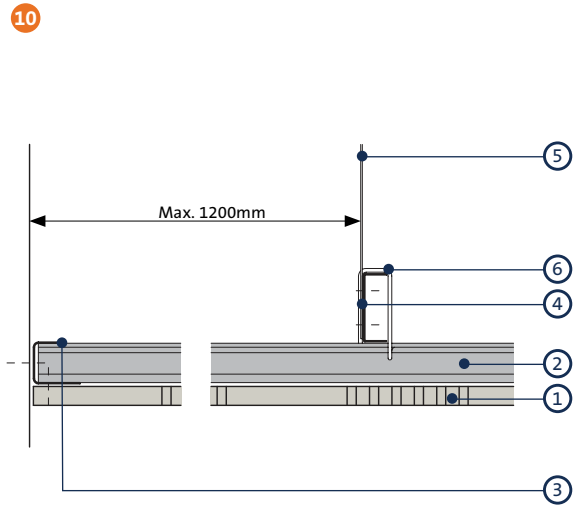


Secondary double Casoline MF ceiling

- |  |   |
|--|---|
| 1 Gyproc plasterboard or Glasroc specialist board        | 8 Gypframe MF12 Soffit Cleat                                    |
| 2 Gypframe MF5 Ceiling Section                           | 9 Gypframe Acoustic Hanger fixed with two Gyproc Drywall Screws |
| 3 Gypframe MF6 Perimeter Channel                         | 10 M6 bolt and locking nut (by others)                          |
| 4 Gypframe MF7 Primary Support Channel                   | 11 Timber joist floor   |
| 5 Gypframe MF8 Strap Hanger or Gypframe FEA1 Steel Angle | 12 Isover insulation  |
| 6 Gyproc Wafer Head Jack-Point Screw                     | 13 Gypframe FEA1 Steel Angle                                    |
| 7 Gypframe MF11 Nut and Bolt                             |   |

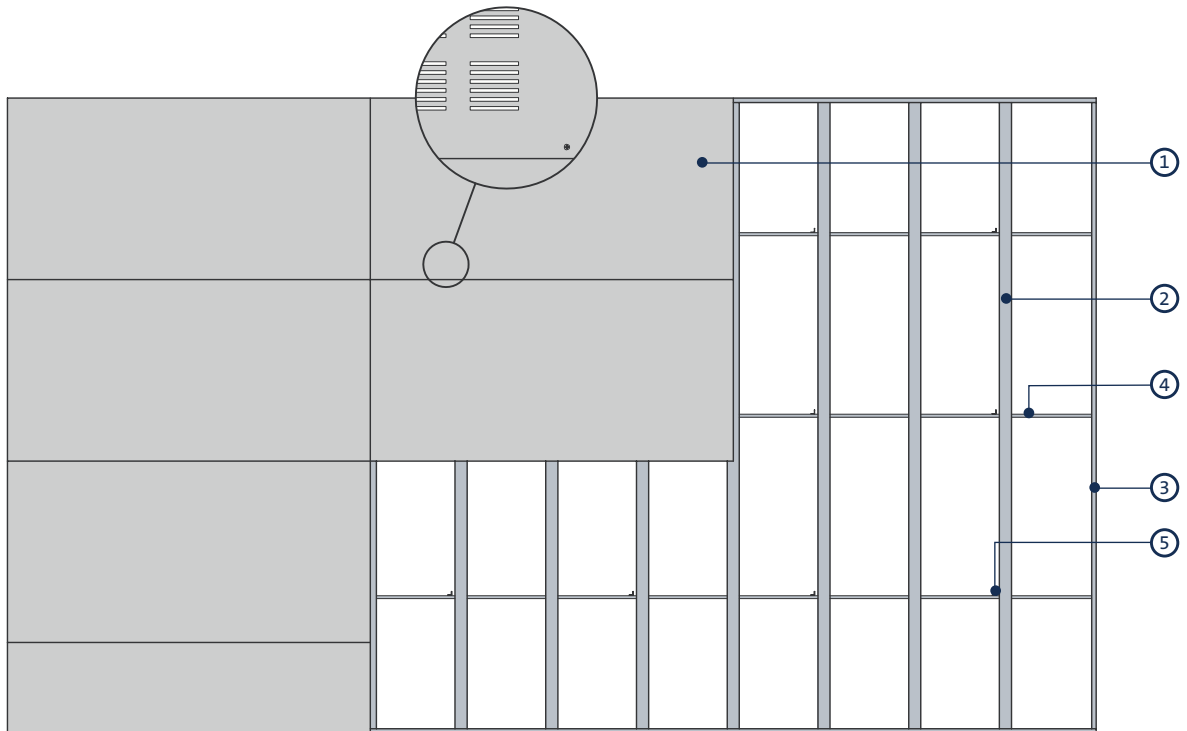


Perimeter parallel to Gyptone MF5 Ceiling Section  
- Gyptone



Perimeter perpendicular to Gyptone MF5 Ceiling Section  
- Gyptone

11



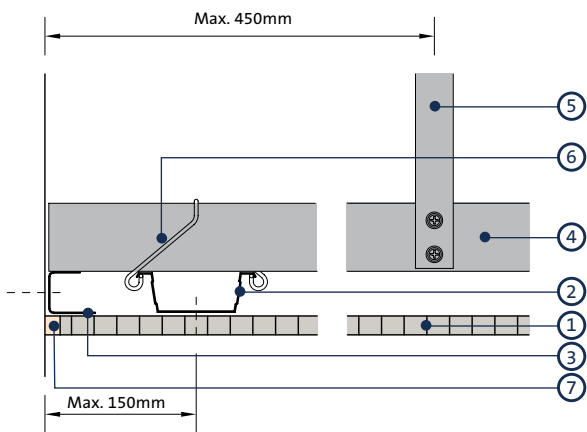
Reflected ceiling plan - Gyptone

- 1 Gyptone boards
- 2 Gyptone MF5 Ceiling Section
- 3 Gyptone MF6 Perimeter Channel

- 4 Gyptone MF7 Primary Support Channel
- 5 Gyptone MF8 Strap Hanger or Gyptone FEA1 Steel Angle
- 6 Gyptone MF9 Connecting Clip

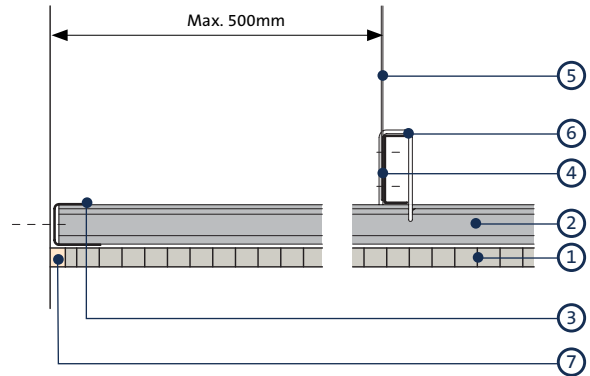
## Casoline MF construction details (continued)

12



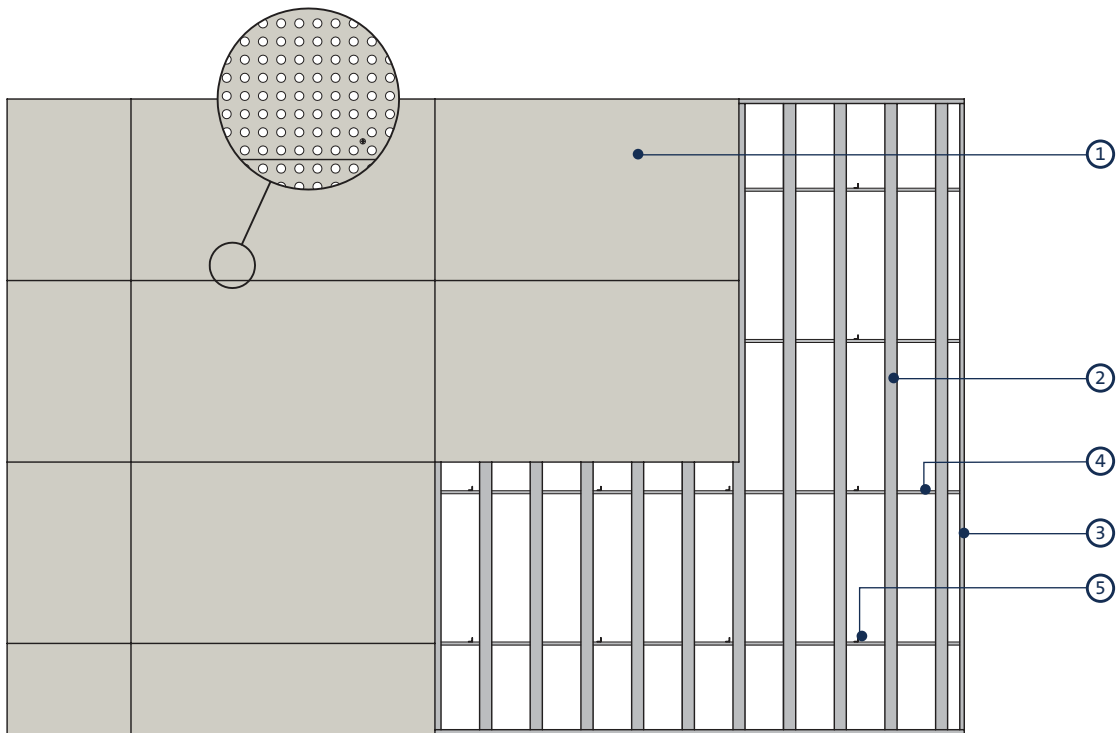
Perimeter parallel to Gyprock MF5 Ceiling Section  
- Rigitone

13



Perimeter perpendicular to Gyprock MF5 Ceiling Section  
- Rigitone

14



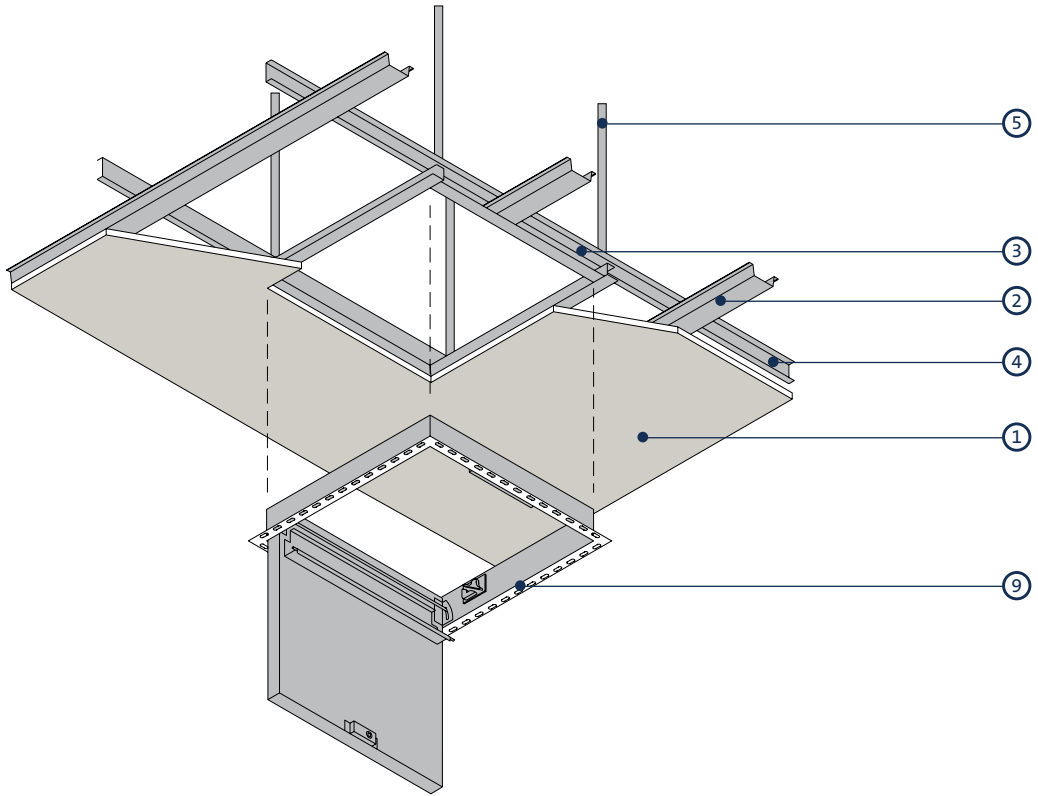
Reflected ceiling plan - Rigitone

- 1 Rigitone boards
- 2 Gyprock MF5 Ceiling Section
- 3 Gyprock MF6 Perimeter Channel
- 4 Gyprock MF7 Primary Support Channel

- 5 Gyprock MF8 Strap Hanger or Gyprock FEA1 Steel Angle
- 6 Gyprock MF9 Connecting Clip
- 7 Rigitone Vario 60 filler

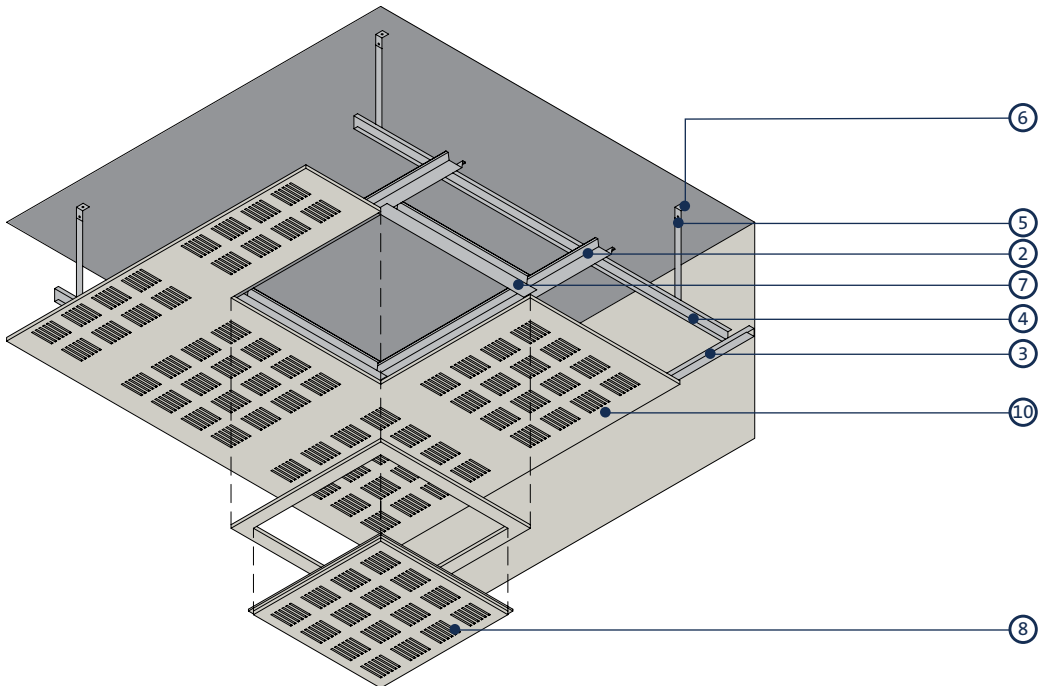
**NB** A special procedure is used for fixing and jointing Rigitone boards. Detailed installation notes are given in the current Gyprock Installation Guide, available to download from [gyproc.ie](http://gyproc.ie)

15



Gyproc Proflex Access panel installation

16



Gyptone Access Hatch installation

- 1 Gyproc plasterboard or Glasroc specialist board
- 2 Gypframe MF5 Ceiling Section
- 3 Gypframe MF6 Perimeter Channel
- 4 Gypframe MF7 Primary Support Channel
- 5 Gypframe MF8 Strap Hanger or Gypframe FEA1 Steel Angle

- 6 Gypframe MF12 Soffit Cleat with MF11 Nut and Bolt
- 7 Gypframe MF5 Ceiling Section with ends tabbed and fixed
- 8 Gyptone Access Hatch (510 x 510mm) with frame (600 x 600mm)
- 9 Access panel (by others)
- 10 Gyptone board

# Casoline MF system components

## Gypframe metal components



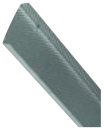
### Gypframe MF6 Perimeter Channel

Perimeter section to support Gypframe MF5 Ceiling Section and fixing of board.



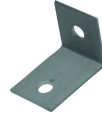
### Gypframe MF9 Connecting Clips

Alternative method of connecting Gypframe MF5 Ceiling Section to Gypframe MF7 Primary Support Channel used in non-pressurised rooms.



### Gypframe MF7 Primary Support Channel

Primary section to support Gypframe MF5 Ceiling Section.



### Gypframe MF12 Soffit Cleat

Suspension point, one leg connected to structural soffit and the other leg connected to suspension hanger Gypframe FEA1 Steel Angle or Gypframe MF8 Strap Hanger recommended for all double and triple boarded solutions.



### Gypframe MF5 Ceiling Section

Designed to provide seamless suspended ceilings and secondary section to support fixing of board.



### Gypframe MF11 Nut & Bolt

For connecting suspension hanger (Gypframe FEA1 or MF8) to Gypframe MF12 Soffit Cleat recommended for all double and triple boarded solutions.



### Gypframe MF8 Strap Hanger

Alternative suspension of ceiling grid, typically 1 metre maximum drop.



### Gypframe GAH1 (35mm) or GAH2 (70mm) Acoustic Hanger

Suspension point for enhanced acoustic performance to timber floors.



### Gypframe FEA1 Steel Angle

Steel angle providing framing stability and board support. Preferred rigid hanger suspension of ceiling grid.

## Board products



### Gyproc WallBoard<sup>1</sup>

Standard gypsum plasterboard.



### Gyproc Duraline<sup>3</sup>

Gypsum plasterboard with fire resistant additives and a high density core for enhanced sound insulation and impact resistance performance.



### Gyproc FireLine<sup>1,3</sup>

Gypsum plasterboard with fire resistant additives.



### Gyproc Plank

Standard gypsum plasterboard located as an inner layer.



### Gyproc SoundBloc<sup>2</sup>

Gypsum plasterboard with a high density core for enhanced sound insulation performance.



### Glasroc F MULTIBOARD

Non-combustible glass-reinforced gypsum board.



### Glasroc F FIRECASE

Non-combustible glass-reinforced gypsum board giving up to 120 minutes fire protection.



### Ceiling boards

A full range of Gyptone<sup>2</sup> and Rigitone<sup>2</sup> boards are available to meet specific aesthetic and/or acoustic requirements.

<sup>1</sup> Also available in DUPLEX grades where vapour control is required.

<sup>2</sup>  ActivAir<sup>®</sup> Technology as standard.

<sup>3</sup> Also available in Moisture Resistant (MR) version. MR boards are specified in intermittent wet use areas.

### Fixing products



#### Gyproc Drywall Screws

Corrosion resistant self-tapping steel screws for fixing board-to-timber and board-to-metal framing less than 0.8mm thick.



#### Gyproc Wafer Head Jack-Point Screws

Corrosion resistant self-tapping steel screws for fixing metal to metal framing 0.8mm thick and greater.



#### Gyproc Collated Drywall Screws

Corrosion resistant self-tapping steel screws for fixing board-to-timber and board-to-metal framing less than 0.8mm thick.



#### Rigitone Screws

Specifically designed for fixing Rigitone board to metal framing.



#### Gyproc Wafer Head Drywall Screws

Corrosion resistant self-tapping steel screws for fixing metal to metal framing less than 0.8mm thick.

### Plasterboard accessories



#### Gyproc Jointing Materials

Jointing compounds, ready mixes and adhesives for reinforcement and finishing of board joints.



#### Gyproc Sealant

Used to seal air paths for optimum sound insulation.



#### Gyproc Control Joint

To accommodate structural movement of up to 7mm.



#### Gyproc Drywall Primer

A general purpose plasterboard primer, providing an ideal surface for decoration for most paints and wall coverings.



#### Gyproc Drywall Primer

Used to prepare for painting. Tub contents 10 litre.



#### Gyproc Paper Joint Tape

A paper tape designed for reinforcement of flat joints or internal angles.

### Plaster products



#### Gyproc Skimcoat

To provide a plaster skim finish on most common backgrounds including undercoat plasters and plasterboard. Can provide enhanced acoustic performance.



#### Gyproc Carlite Finish

To provide a plaster skim finish on most common backgrounds including undercoat plasters and plasterboard. Can provide enhanced acoustic performance.



#### Gyproc Carlite Ultra Finish

Offers all the benefits of Gyproc Skimcoat and Gyproc Carlite Finish with a reduced set time of 90-120mins, making it ideal for smaller jobs.



#### Plaster accessories

Designed for the reinforcement and finishing of board joints before plaster skimming.

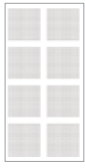


#### Gyproc Bonding Coat

A lightweight undercoat plaster for use over smooth or medium suction backgrounds. Applied at a depth of 10mm on walls or 8mm on ceilings. Bonding Coat Short Set also available with a reduced set time of 90-120 mins making it ideal for smaller jobs.

## Casoline MF system components (continued)

### Ceiling products



#### Gyptone BIG QUATTRO 41<sup>1</sup>

Acoustic board with square perforations capable of providing Class C sound absorption.



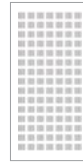
#### Gyptone BIG QUATTRO 47<sup>1</sup>

Acoustic board with occasional square perforations and Class D absorption.



#### Gyptone BIG QUATTRO 46<sup>1</sup>

Acoustic board with intermittent square perforations capable of providing Class D absorption.



#### Gyptone BIG LINE 6<sup>1</sup>

Gyptone board with a linear perforated pattern capable of providing Class D absorption.



#### Gyptone SIXTO 63<sup>1</sup>

Gyptone board with a unique hexagonal perforated pattern capable of providing Class C absorption.



#### Rigitone 12-20/66<sup>1</sup>

Acoustic board with a perforated pattern of 12mm and 20mm circles capable of providing up to Class C absorption.



#### Rigitone 10/23<sup>1</sup>

Acoustic board with a perforated pattern of 10mm circles capable of providing up to Class C absorption.



#### Rigitone 15/30<sup>1</sup>

Acoustic board with a perforated pattern of 15mm circles capable of providing up to Class C absorption.



#### Rigitone 8-15-20 SUPER<sup>1</sup>

Acoustic board with a random pattern of 8mm, 15mm and 20mm circles capable of providing up to Class D absorption.



#### Rigitone 8/18<sup>1</sup>

Acoustic board with a perforated pattern of 8mm circles capable of providing up to Class C absorption.



#### Rigitone Spacing Tool

Spacer tool used to ensure accurate installation of Rigitone boards.



#### Rigitone Vario 60 Jointing Material

High-strength jointing material used for jointing of Rigitone boards.



#### Rigitone Large Jointing Kit

Jointing kit for application of Vario 60 into Rigitone boards.

<sup>1</sup> ACTIV AIR<sup>®</sup> technology as standard.

### Ceiling products (continued)



#### Gyptone BIG QUATTRO 46 Access Hatch<sup>1</sup>

Access hatch for providing access points in Gyptone QUATTRO 46 board ceilings.



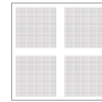
#### Gyptone BIG LINE 6 Access Hatch<sup>1</sup>

Access hatch for providing access points in Gyptone LINE 6 board ceilings.



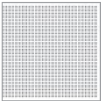
#### Gyptone BIG QUATTRO 47 Access Hatch<sup>1</sup>

Access hatch for providing access points in Gyptone QUATTRO 47 board ceilings.



#### Gyptone BIG QUATTRO 41 Access Hatch<sup>1</sup>

Access hatch for providing access points in Gyptone QUATTRO 41 board ceilings.



#### Gyptone BIG SIXTO 63 Access Hatch<sup>1</sup>

Access hatch for providing access points in Gyptone SIXTO 63 board ceilings.

### Access panels (▶ Refer to the Gyproc Technical Department for details)



#### Profilex Access Panel

Panel for access to cavity.

### Insulation products



#### Isover Acoustic Roll

Glass mineral wool for enhanced acoustic performance.



#### Isover Sound Deadening Floor Slab

Glass mineral wool for enhanced acoustic performance.



#### Stone Mineral Wool

(45kg/m<sup>3</sup> or 100kg/m<sup>3</sup>, by others)  
For fire performance.



#### Isover Spacesaver Ready-Cut

Glass mineral wool for enhanced acoustic and thermal performance.

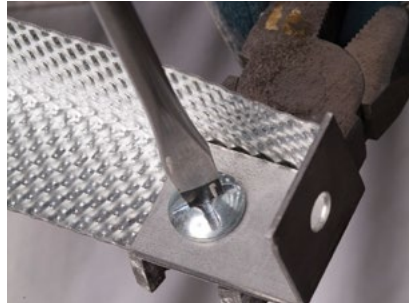
<sup>1</sup> ACTIVair technology as standard.

## Casoline MF installation overview

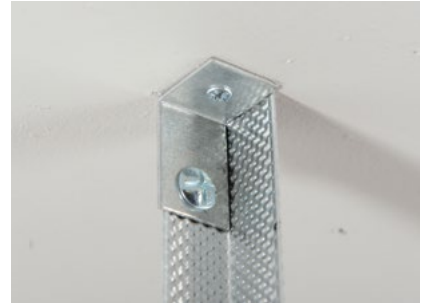
This is intended to be a basic description of how the system is built.



Gypframe MF6 Perimeter Channels are fixed to the perimeter walls at 600mm centres.



Gypframe FEA1 Steel Angle or Gypframe MF8 Strap Hanger is secured to Gypframe MF12 Soffit Cleats with Gypframe MF11 Nuts and Bolts to form hangers.



These hangers are then suitably fixed to the soffit at the required centres.



Gypframe MF7 Primary Support Channels are fixed to the hangers with Gyproc Wafer Head Jack-Point Screws, two per hanger.



Gypframe MF5 Ceiling Sections are fixed to the underside of the Gypframe MF7 Primary Support Channels to form a grid with Gyproc Wafer Head Jack-Point Screws.



Alternatively, in areas not prone to ceiling lift, Gypframe MF9 Connecting Clips.



Gyproc plasterboards, Glasroc specialist boards, Gyptone boards or Rigitone boards are then screw fixed to the Gypframe MF5 Ceiling Sections and Gypframe MF6 Perimeter Channels with Gyproc Drywall Screws.



### Additional information

For full installation details, refer to the **Gyproc Installation Guide**, available to download from [gyproc.ie](http://gyproc.ie)



# Gyplyner

Concealed grid ceiling lining system

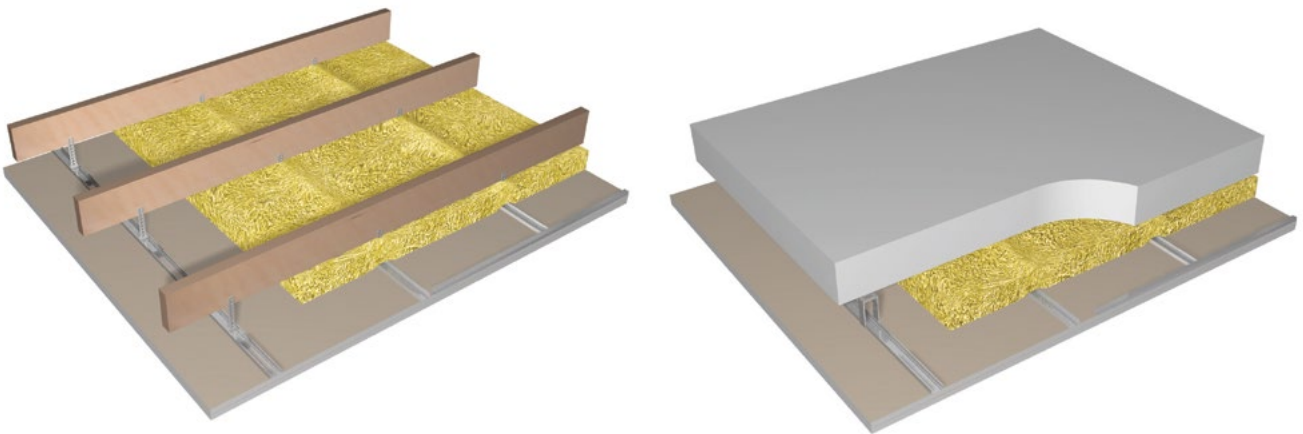
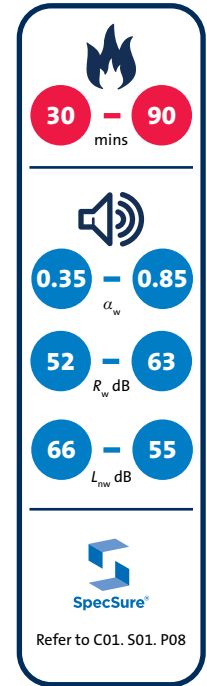


# GyLyner

**GyLyner** is a versatile ceiling lining system suitable for a wide range of installations, ranging from residential properties to large commercial developments. Simple to install, and compatible with the full range of Gyproc boards, **GyLyner** can be used to significantly improve performance levels in a refurbishment project and can also be used for new build installations.

## Key benefits

- A versatile system that is suitable for concrete soffits or timber joists, and utilises the same components for either wall or ceiling installations
- Can also be installed onto a plasterboard ceiling, making it ideal for refurbishment projects where it is desirable or necessary to retain the existing ceiling
- Ideal for meeting the diverse range of performance requirements of modern construction - compatible with the full range of Gyproc boards, including, Glasroc, Gyptone and Rigitone ranges
- Minimal loss of room height with as little as 25mm cavity required
- Fire and acoustic performance upgrades can be achieved with access to the underside of the floor only



# Gyplyner performance

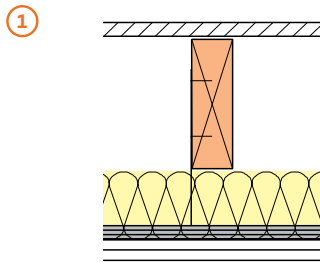
## Fixing to new or existing solid timber joist floors

### Upgrade to an existing floor requires access from below only

For details of when to specify fire resistance using EN  
 ▶ Refer to **C02. S01. P18**



**Table 1 – Solutions to satisfy the requirements of BS EN 1365-2: 2000**



21mm t&g flooring over 38mm x 195mm (minimum) timber joists at 600mm (maximum) centres.

Gyplyner ceiling fixed to underside of joists with Gypframe GL1 Lining Channels at 450mm maximum centres. 100mm Isover Spacesaver Ready-Cut in the cavity. Ceiling linings as in table. 100% loadbearing ratio.

Detail	Board type	Lining thickness mm	Sound insulation		System reference
			Airborne $R_w$ dB	Impact $L_{nw}$ dB	
<b>60 minutes fire resistance</b>					
	Gyproc SoundBloc	2 x 15	54	65	C106020
	Gyproc Plank + Gyproc FireLine	1 x 19 + 1 x 12.5	54	65	C106021

▶ For further assistance in choosing the right solution for your project, try our System Selector; an online tool that enables quick and easy filtering by performance criteria. It provides system specific information downloads including BIM (Revit) objects. Go to [gyproc.ie](http://gyproc.ie)

**NB** The fire resistance and sound insulation performances are for imperforate partitions, walls and ceilings incorporating boards with all joints taped and filled, or skimmed according to Gyproc's recommendations. The quoted performances are achieved only if Gyproc and Isover components are used throughout, and the Company's fixing recommendations are strictly observed. Any variation in the specifications should be checked with Gyproc.

**NB** If preferred, the existing ceiling may be retained. The new Gyplyner ceiling is installed with Gypframe GL6 Timber Connectors or Gypframe GL2, GL9 or GL12 Brackets, fixed through the existing ceiling into the joists.

**NB** The maximum substantiated span on the above solid timber joist systems is 4000mm. For any spans greater than this please contact our Technical Department.

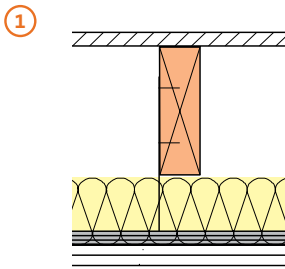
## Gyplyner performance (continued)

### Upgrading existing solid timber joist floors - ceiling replaced Upgrade to an existing floor requires access from below only

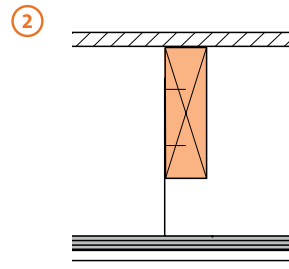
For details of when to specify fire resistance using BS  
Refer to C02. S01. P18



Table 2 – Solutions to satisfy the requirements of BS 476: Part 21: 1987



Existing floor retained minimum 18mm t&g. Existing wood lath and plaster ceiling removed. Gyplyner ceiling suspended with Gypframe GL1 Lining Channels at 450mm maximum centres. 100mm Iover Spacesaver Ready-Cut in the cavity. Ceiling linings as in table. 100% loadbearing ratio.



Existing floor retained minimum 22mm t&g. Gyplyner ceiling suspended with Gypframe GL1 Lining Channels at 450mm maximum centres. Ceiling linings as in table. 100% loadbearing ratio.

Detail	Board type	Lining thickness mm	Joist centres mm	Joist size mm	Sound insulation		System reference
					Airborne $R_w$ dB	Impact $L_{nw}$ dB	
<b>30 minutes fire resistance</b>							
①	Gyproc SoundBloc	2 x 12.5	450	200 x 50	54	65	C154004
<b>60 minutes fire resistance</b>							
①	Gyproc Plank + Gyproc WallBoard	1 x 19 + 1 x 12.5	600	195 x 45	52	66	C206004
①	Gyproc FireLine	2 x 12.5	450	195 x 45	53	66	C154007
②	Glasroc F MULTIBOARD	1 x 12.5	600	195 x 45	-	-	G106030
<b>90 minutes fire resistance</b>							
②	Glasroc F MULTIBOARD	2 x 12.5	600	200 x 50	-	-	G106033

► For further assistance in choosing the right solution for your project, try our System Selector; an online tool that enables quick and easy filtering by performance criteria. It provides system specific information downloads including BIM (Revit) objects. Go to [gyproc.ie](http://gyproc.ie)

**NB** The fire resistance and sound insulation performances are for imperforate partitions, walls and ceilings incorporating boards with all joints taped and filled, or skimmed according to Gyproc's recommendations. The quoted performances are achieved only if Gyproc and Iover components are used throughout, and the Company's fixing recommendations are strictly observed. Any variation in the specifications should be checked with Gyproc.

**NB** For non t&g floors, overlay with 6mm plywood and ensure all joints are staggered.

## Gyplyner performance (continued)

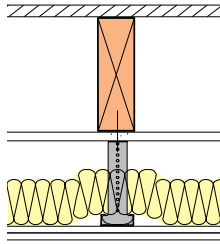
### Upgrading existing solid timber joist floors - ceiling retained Upgrade to an existing floor requires access from below only

For details of when  
to specify fire  
resistance using BS  
▶ Refer to C02. S01. P18



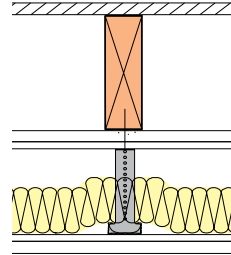
Table 3 – Solutions to satisfy the requirements of BS 476: Part 21: 1987

①



18mm t&g flooring grade chipboard and existing ceiling of 9.5mm Gyproc WallBoard. Gyplyner ceiling<sup>1</sup> suspended with Gypframe GL1 Lining Channels at 450mm maximum centres to give a minimum cavity of 50mm to a maximum of 145mm. 50mm Isover Acoustic Roll in the cavity. Ceiling linings as in table. 100% loadbearing ratio.

②



18mm t&g flooring grade chipboard and ceiling of Gyproc Plank and 12.5mm Gyproc WallBoard to simulate a wood lath and plaster ceiling<sup>2</sup>. Gyplyner ceiling<sup>1</sup> suspended with Gypframe GL1 Lining Channels at 450mm maximum centres to give a minimum cavity of 50mm to a maximum of 145mm. 50mm Isover Acoustic Roll in the cavity. Ceiling linings as in table. 100% loadbearing ratio.

Detail	Board type	Lining thickness mm	Joist centres mm	Joist size mm	Sound insulation		System reference
					Airborne $R_w$ dB	Impact $L_{nw}$ dB	
<b>30 minutes fire resistance</b> BS							
②	Gyproc FireLine	1 x 12.5	450	195 x 45	53	64	C154003
<b>60 minutes fire resistance</b> BS							
①	Gyproc FireLine	2 x 12.5	450	195 x 45	56	62	C154005
②	Gyproc FireLine	2 x 12.5	450	195 x 45	59	59	C154006

▶ For further assistance in choosing the right solution for your project, try our System Selector; an online tool that enables quick and easy filtering by performance criteria. It provides system specific information downloads including BIM (Revit) objects. Go to [gyproc.ie](http://gyproc.ie)

<sup>1</sup> Gypframe GL6 Timber Connectors are bent at a position between the third and fourth holes along (forming a 30mm horizontal leg) to form a right angle, and fixed through the existing ceiling with suitable fixings. Alternatively, use Gypframe GL2, GL9 or GL12 Brackets.

<sup>2</sup> Existing lath and plaster ceiling (up to 20mm thick) should be supported by chicken wire, securely fixed to the joists.

**NB** The fire resistance and sound insulation performances are for imperforate partitions, walls and ceilings incorporating boards with all joints taped and filled, or skimmed according to Gyproc's recommendations. The quoted performances are achieved only if Gyproc and Isover components are used throughout, and the Company's fixing recommendations are strictly observed. Any variation in the specifications should be checked with Gyproc.

**NB** For non t&g floors, overlay with 6mm plywood and ensure all joints are staggered.

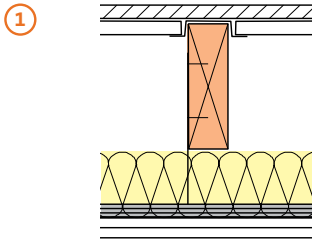
## GypLyner performance (continued)

### Upgrading existing solid timber joist floors Upgrade to an existing floor

For details of when  
to specify fire  
resistance using BS  
▶ Refer to **C02. S01. P18**



Table 4 – Solutions to satisfy the requirements of BS 476: Part 21: 1987



**GypFloor SILENT** comprising minimum 21mm t&g softwood floor boarding with Gyproc Plank on Gypframe SIF Floor Channels. **GypLyner** ceiling suspended with Gypframe GL1 Lining Channels at 450mm maximum centres. 100mm Isover Spacesaver Ready-Cut in the cavity. Ceiling linings as in table. 100% loadbearing ratio.

Detail	Board type	Lining thickness mm	Joist centres mm	Joist size mm	Sound insulation		System reference
					Airborne $R_w (R_w + C_{tr})$ dB	Impact $L_{nw}$ dB	
<b>60 minutes fire resistance</b>							
<b>1</b>	Gyproc Plank + Gyproc SoundBloc	1 x 19 + 1 x 12.5	450	200 x 50	63 (50)	55	C154008

▶ For further assistance in choosing the right solution for your project, try our System Selector; an online tool that enables quick and easy filtering by performance criteria. It provides system specific information downloads including BIM (Revit) objects. Go to [gyproc.ie](http://gyproc.ie)

**NB** The fire resistance and sound insulation performances are for imperforate partitions, walls and ceilings incorporating boards with all joints taped and filled, or skimmed according to Gyproc's recommendations. The quoted performances are achieved only if Gyproc and Isover components are used throughout, and the Company's fixing recommendations are strictly observed. Any variation in the specifications should be checked with Gyproc.

**NB** For non t&g floors, overlay with 6mm plywood and ensure all joints are staggered.

# Gyplyner design

## Building design

Gyplyner comprises Gypframe CL1 Channels suspended by Gypframe brackets (for flat soffits) or Gypframe Timber Connectors (for timber joists). The ceilings boards are screw fixed to the underside of the Gypframe GL1 Channels.

## Planning – key factors

The depth of the ceiling cavity is determined by the positioning of the fixing brackets. For concrete soffits the fixing brackets allow sufficient adjustment for levelling the ceiling. When using Gypframe GL2 Brackets, allow for a stand-off of 25mm - 75mm plus the lining thickness. When using Gypframe GL9 Brackets, allow for a stand-off of 25mm - 125mm plus the lining thickness. When using Gypframe GL12 Brackets, allow for a stand-off of 25mm - 175mm plus the lining thickness. When fixing to timber joists using Gypframe GL5 or GL6 Timber Connectors, allow for a maximum cavity depth of 35mm and 120mm respectively, measured from the bottom of the joists to the underside of the lining.



### Handy hint

A maximum stand-off of 175mm can be accommodated by the Gyplyner system. For increased plenum depths.

▶ Refer to C06. S02. P355 – **Casoline MR**.

## Cavity fire barriers

Where cavity fire barriers are required, these can be formed using Gyproc FireLine or Glasroc F MULTIBOARD screw-fixed to a simple frame. The framing should be fixed to the structure to avoid undue loading of the ceiling suspension grid or, alternatively, additional fixing brackets should be incorporated to support the ceiling alongside the cavity fire barrier.

▶ Refer to C06. S06. P422 – Cavity fire barriers.

## Relative humidity

Gyplyner ceilings lined with Gyproc, Gyptone, Rigitone or Gyproc Specialist Boards are suitable for use under normal occupancy conditions. Buildings in which they are used should be dry, glazed and enclosed, with environmental conditions of no greater than 70% RH at 10°C to 20°C. For high humidity / high moisture conditions use Gyproc plasterboard MR variants or Glasroc F MULTIBOARD.

▶ Refer to C02. S01. P39 – Robustness.

## Vapour control

Isover Vario membranes may be used to provide vapour control to ceilings.

## Acoustic performance

Gyptone and Rigitone boards are perforated and designed to provide sound absorption when used in conjunction with an airspace behind the ceiling. Increased levels of sound absorption can be achieved by including insulation over the back of the ceiling. Where sound insulation room-to-room is required, sound attenuation  $D_{n,c,w}$  of 39dB can be achieved by the inclusion of 100mm Isover Spacesaver Ready-Cut over the back of the ceiling. Alternatively, other design considerations should be adopted such as extending adjoining partitions into the plenum void or installing a plenum barrier.

▶ Refer to C06. S01. P349 – Floors and ceilings introduction, table 1 and 2.

## Thermal performance

Isover insulation can be laid over the suspension grid to provide the required standard of thermal insulation. Contact the Gyproc Technical Department for further guidance.

## Control joints

Gyproc Control Joints may be required in the ceiling to relieve stresses induced by expansion and contraction of the structure. It is recommended that they coincide with movement joints within the surrounding structure.

## Fixing to the structure

Gypframe GL8 Track is suitably fixed to the perimeter at 600mm centres. Gypframe GL11 Gyplyner Anchors are suitable for fixing brackets to solid concrete soffits. Refer to table below for fixing centres:

## Services

Table 5 – Maximum component centres (mm)

Lining	Gyplyner GL1	Gyplyner GL2 or GL9 or GL12	Gyplyner GL5 or GL6
12.5mm	450	1200	600
15mm	600	1200	600
2 x 12.5mm	450	1200	600
2 x 15mm	600	1200	600
Rigitone board	330	1200	600
Gyptone board	600	1200	600

## Gyplyner design (continued)

The cavity above the metal framework facilitates the incorporation of services. Pipes and conduits should be fixed in position before installing the framing. Where light fittings, access panels and similar components are incorporated as part of the design requirements, consideration must be given to maintaining the integrity of the ceiling to meet fire resistance and sound insulation requirements. Cables, pipework and conduits, should be independently supported from the building structure.

### Fixtures

Fixtures with a maximum weight of 3kg, e.g. single lights, can be fixed into the channels. For other fixtures, independent suspension should be provided from the structure.

### Board finishing

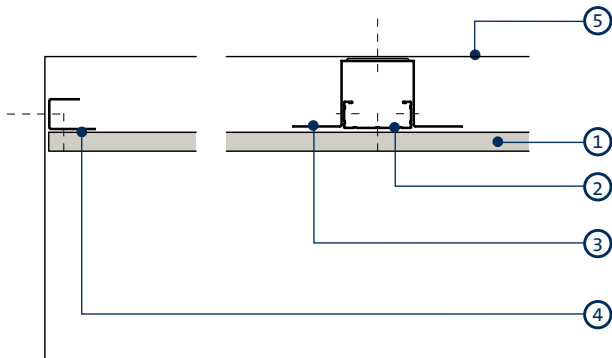
▶ Refer to C08. S01. P483 – Finishes.

Additional care and attention should be exercised when jointing Rigitone and Gyptone boards so as not to fill the perforations and impair the acoustic performance of the finished ceiling.

▶ Refer to Gyproc Installation Guide.

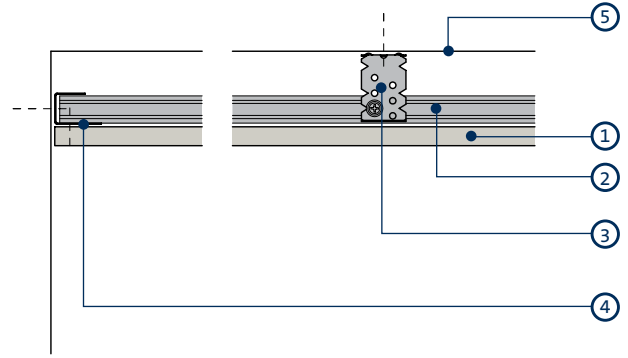
# Gyplyner construction details

1



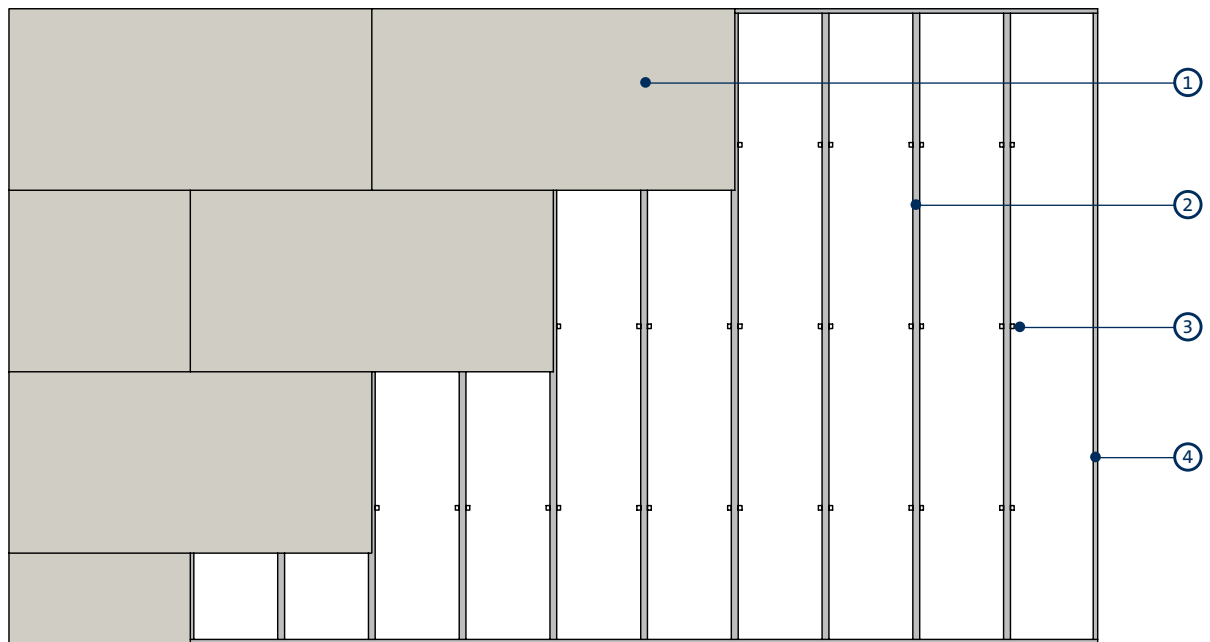
Perimeter parallel to Gypframe GL1 Lining Channel  
for flat soffit

2



Perimeter perpendicular to  
Gypframe GL1 Lining Channel for flat soffit

3

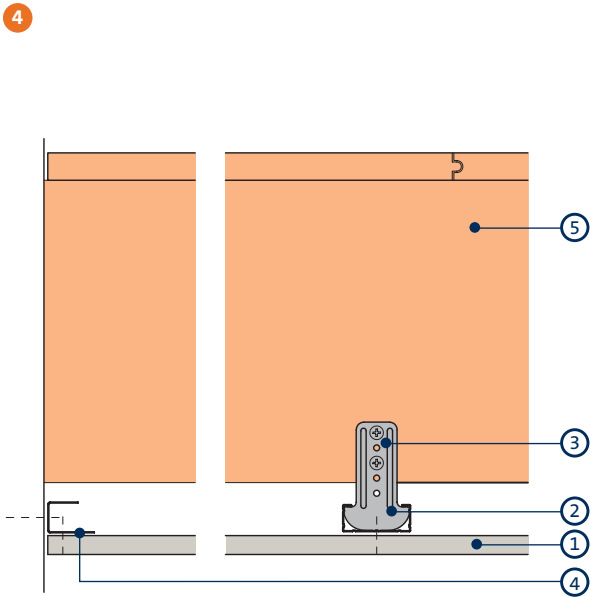


Reflected ceiling plan for flat soffit - single layer 15mm Gyproc plasterboard with channels at 600mm maximum centres, 12.5mm Gyproc plasterboard with channels at 450mm maximum centres, Gypstone board with channels at 600mm maximum centres or Rigitone board at 330mm maximum centres

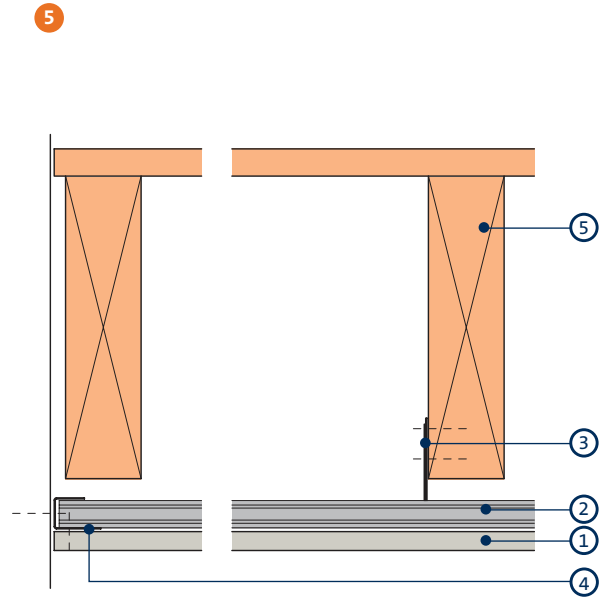
- 1 Gyproc, Gypstone or Rigitone boards
- 2 Gypframe GL1 Lining Channel
- 3 Gypframe GL2, GL9 or GL12 Bracket

- 4 Gypframe GL8 Track
- 5 Flat soffit

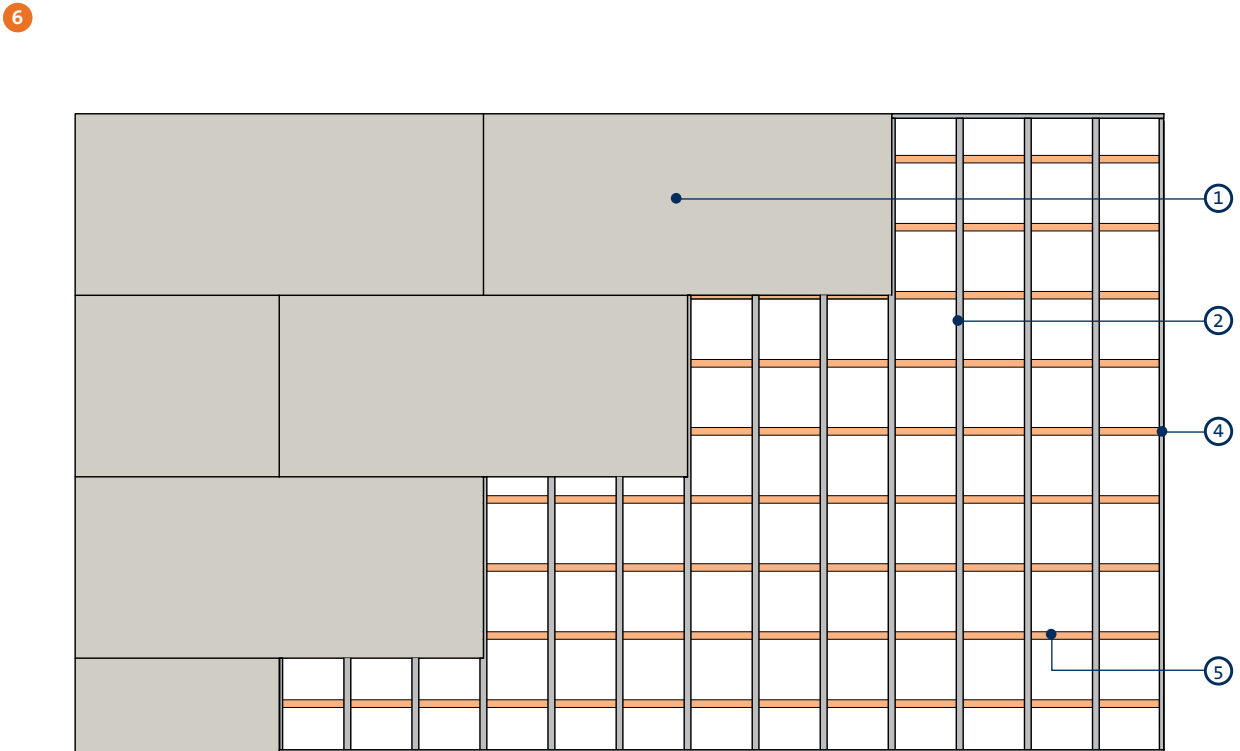
## Gyplyner construction details (continued)



Perimeter parallel to  
Gypframe GL1 Lining Channel for timber joist floor



Perimeter perpendicular to  
Gypframe GL1 Lining Channel for timber joist floor



Reflected ceiling plan for timber joist floor - single layer 15mm Gyproc plasterboard with channels at 600mm maximum centres, 12.5mm Gyproc plasterboard with channels at 450mm maximum centres, Gyptone board with channels at 600mm maximum centres or Rigitone board at 330mm maximum centres

- 1 Gyproc, Gyptone or Rigitone boards
- 2 Gypframe GL1 Lining Channel
- 3 Gypframe GL5 or GL6 Timber Connector

- 4 Gypframe GL8 Track
- 5 Timber joist floor

**NB** Gypframe GL5 or Gypframe GL6 Timber Connectors not shown on construction detail 6.

# Gyplyner system components

## Gypframe metal components



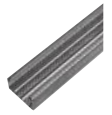
### Gypframe GL8 Track

Ceiling track for retaining the Gypframe GL1 Lining Channel at wall abutments.



### Gypframe GL5 Timber Connector

For connecting the Gypframe GL1 Lining Channel to timber joists with a maximum 35mm drop.



### Gypframe GL1 Lining Channel

Main support channel to receive fixing of board.



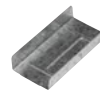
### Gypframe GL6 Timber Connector

For connecting the Gypframe GL1 Lining Channel to timber joists with a maximum 120mm drop.



### Gypframe GL2 Bracket

For connecting the Gypframe GL1 Lining Channel to the soffit with a maximum 75mm stand-off.



### Gypframe GL3 Channel Connector

For joining two sections of Gypframe GL1 Lining Channel.



### Gypframe GL9 Bracket

For connecting the Gypframe GL1 Lining Channel to the soffit with a maximum 125mm stand-off.



### Gypframe GL11 Gyplyner Anchors

For fixing Gypframe GL2, GL9 and GL12 Brackets to concrete soffits.



### Gypframe GL12 Bracket

For connecting the Gypframe GL1 Lining Channel to the soffit with a maximum 175mm stand-off.

## Board products



### Gyproc WallBoard

Standard gypsum plasterboard.



### Gyproc SoundBloc<sup>2</sup>

Gypsum plasterboard with a high density core for enhanced sound insulation performance.



### Gyproc FireLine<sup>2</sup>

Gypsum plasterboard with fire resistant additives.



### Gyproc Plank

Standard gypsum plasterboard located as an inner layer.



### Glasroc F MULTIBOARD

Non-combustible glass-reinforced gypsum board.



### Ceiling boards

A full range of Gypstone<sup>1</sup> and Rigitone<sup>1</sup> boards are available to meet specific aesthetic and/or acoustic requirements.

<sup>1</sup> ActivAir<sup>®</sup> technology as standard.

<sup>2</sup> Also available in Moisture Resistant (MR) version. MR boards are specified in intermittent wet use areas.

## Fixing products



### Gyproc Drywall Screws

Corrosion resistant self-tapping steel screws for fixing board-to-timber and board-to-metal framing less than 0.8mm thick.



### Gyproc Wafer Head Drywall Screws

Corrosion resistant self-tapping steel screws for fixing metal to metal framing less than 0.8mm thick.



### Gyproc Collated Drywall Screws

Corrosion resistant self-tapping steel screws for fixing board-to-timber and board-to-metal framing less than 0.8mm thick.

## Gypliner system components (continued)

### Plasterboard accessories



#### Gyproc Jointing Materials

Jointing compounds, ready mixes and adhesives for reinforcement and finishing of board joints.



#### Gyproc Sealant

Used to seal air paths for optimum sound insulation.



#### Gyproc Drywall Primer

Used to prepare for painting. Tub contents 10 litre.



#### Gyproc Paper Joint Tape

A paper tape designed for reinforcement of flat joints or internal angles.

### Plaster products



#### Gyproc Skimcoat

To provide a plaster skim finish on most common backgrounds including undercoat plasters and plasterboard. Can provide enhanced acoustic performance.



#### Gyproc Carlite Finish

To provide a plaster skim finish on most common backgrounds including undercoat plasters and plasterboard. Can provide enhanced acoustic performance.



#### Gyproc Carlite Ultra Finish

Offers all the benefits of Gyproc Skimcoat and Gyproc Carlite Finish with a reduced set time of 90-120mins, making it ideal for smaller jobs.



#### Plaster accessories

Designed for the reinforcement and finishing of board joints before plaster skimming.



#### Gyproc Bonding Coat

A lightweight undercoat plaster for use over smooth or medium suction backgrounds. Applied at a depth of 10mm on walls or 8mm on ceilings. Bonding Coat Short Set also available with a reduced set time of 90-120 mins making it ideal for smaller jobs.

### Ceiling products



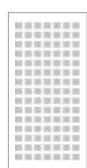
#### Gyptone BIG QUATTRO 41<sup>1</sup>

Acoustic board with square perforations capable of providing Class C sound absorption.



#### Gyptone BIG QUATTRO 47<sup>1</sup>

Acoustic board with occasional square perforations and Class D absorption.



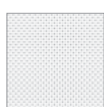
#### Gyptone BIG LINE 6<sup>1</sup>

Gyptone board with a linear perforated pattern capable of providing Class D sound absorption.



#### Gyptone BIG QUATTRO 46<sup>1</sup>

Acoustic board with intermittent square perforations capable of providing Class D absorption.



#### Rigitone 12-20/66<sup>1</sup>

Acoustic board with a perforated pattern of 12mm and 20mm circles capable of providing Class C sound absorption.



#### Rigitone 10/23<sup>1</sup>

Acoustic board with a perforated pattern of 10mm circles capable of providing Class C sound absorption.



#### Rigitone 15/30<sup>1</sup>

Acoustic board with a perforated pattern of 15mm circles capable of providing Class C sound absorption.



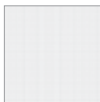
#### Rigitone 8-15-20 SUPER<sup>1</sup>

Acoustic board with a random pattern of 8mm, 15mm and 20mm circles capable of providing Class D sound absorption.

<sup>1</sup> Activ'Air® technology as standard.

## Gypliner system components (continued)

### Ceiling products (continued)



#### Rigitone 8/18<sup>2</sup>

Acoustic board with a perforated pattern of 8mm circles capable of providing Class C sound absorption.



#### Rigitone Spacing Tool

Spacer tool used to ensure accurate installation of Rigitone boards.



#### Rigitone Vario 60 Jointing Material

High-strength jointing material used for jointing of Rigitone boards.



#### Rigitone Large Jointing Kit

Jointing kit for application of Vario 60 into Rigitone boards.

### Insulation products



#### Isover Spacesaver Ready-Cut

Glass mineral wool for enhanced acoustic and thermal performance.



#### Isover Acoustic Roll

Glass mineral wool for enhanced thermal performance.

# Gyplyner installation overview

This is intended to be a basic description of how the system is built.



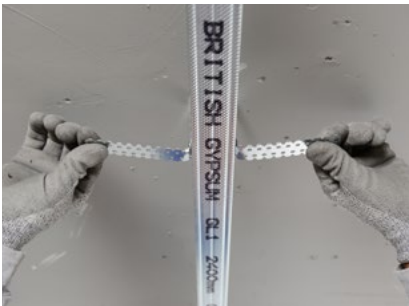
Gypframe GL8 Track is fixed at the perimeter of the room with the longer leg at the bottom.



Gypframe GL2, GL9 or GL12 Brackets are fixed to the soffit at the required centres.



Gypframe GL1 Lining Channels are located into the perimeter track and each leg of the Gypframe GL2, GL9 or GL12 Brackets are screw-fixed to the Gypframe GL1 Lining Channels with Gyproc Wafer Head Drywall Screws.



The protruding legs of each bracket are bent to sit back from the channel face. Gypframe GL1 Lining Channel sections are extended using Gypframe GL3 Channel Connectors.

Additional channel or supplementary framing is installed as required to support fixtures. Boards are fixed to the Gypframe GL1 Lining Channels and Gypframe GL8 Track to form one or two layer linings as specified.



## Fixing to timber joists

Gypframe GL5 or GL6 Timber Connectors are fixed to the side of joists using Gyproc Drywall Screws. The connectors must be aligned accurately since they can not be adjusted once Gypframe GL1 Lining Channel is engaged into a row of timber connectors and twisted into position.



## Additional information

For full installation details, refer to the **Gyproc Installation Guide**, available to download from [gyproc.ie](http://gyproc.ie)

# GypFloor SILENT

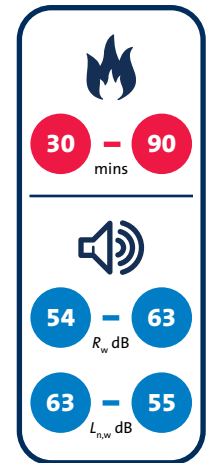
Sound insulating floor system



## GypFloor SILENT

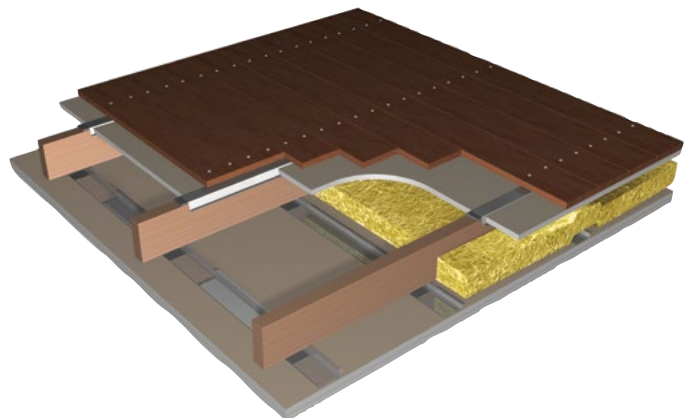
**GypFloor SILENT** is an acoustic floor system, specified in residential conversion or improvement work. It upgrades existing timber joist floors to meet the requirements of Building Regulations for separating floors between rooms created by a change of use or conversion.

**GypFloor SILENT** can also be used in new-build homes for enhanced sound insulation performance of internal floors.



### Key benefits

- Provides a significant uplift in acoustic performance making it an ideal upgrade for transforming a non-performing floor to one that is Building Regulations compliant
- Adds only 7mm to the existing floor height, minimising the impact on existing fixtures and fittings compared to alternative solutions, such as floating floor systems
- The transfer of impact noise through floor structure to the room below, for example impact noise from footfall or furniture movement, is reduced due to the integral neoprene strip located within Gypframe SIF Floor Channels
- Acoustic performance of the floor is further enhanced by installing Gypframe RB1 Resilient Bar to isolate the ceiling lining from the joists
- An existing structure can be improved, in terms of both fire and acoustic performance, without requiring extensive alteration, even where access is available from above only



# GypFloor SILENT performance

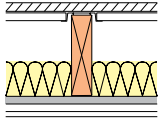
## Ceiling installed to existing solid timber joists

For details of when to specify fire resistance using EN  
 ▶ Refer to C02. S01. P18



Table 1a – Solutions to satisfy requirements of BS EN 1365-2: 2000

1



**GypFloor SILENT** comprising Gyproc Plank on Gyproframe SIF Floor Channel located over timber joists (minimum 195mm deep at 450mm / 600mm centres). Walking surface of chipboard or softwood t&g flooring (21mm minimum). 100mm Isover Spacesaver Ready-Cut in the cavity. Gyproframe RB1 Resilient Bars fixed at maximum 450mm centres. Ceiling linings as in table.

Detail	Ceiling lining	Ceiling depth mm	Board type	Lining thickness mm	Sound insulation		System reference
					Airborne $R_w (R_w + C_{tr})$ dB	Impact $L_{n,w}$ dB	
<b>60 minutes fire resistance</b>							
1	Gyproframe RB1 Resilient Bar	46	Gyproc SoundBloc	2 x 15	61 (48)	56	C204006
1	Gyproframe RB1 Resilient Bar	47.5	Gyproc Plank + Gyproc FireLine	1 x 19 + 1 x 12.5	63 (51) <sup>1</sup>	55	C204003

▶ For further assistance in choosing the right solution for your project, try our System Selector; an online tool that enables quick and easy filtering by performance criteria. It provides system specific information downloads including BIM (Revit) objects. Go to [gyproc.ie](http://gyproc.ie)

<sup>1</sup>This Gyproc Approved System is designed to achieve minimum  $D_{nT,w} + C_{tr}$  43dB and  $L'_{nT,w}$  64dB subject to Pre-Completion Testing.

**NB** The fire resistance and sound insulation performances are for imperforate partitions, walls and ceilings incorporating boards with all joints taped and filled, or skimmed according to Gyproc's recommendations. The quoted performances are achieved only if Gyproc and Isover components are used throughout, and the Company's fixing recommendations are strictly observed. Any variation in the specification should be checked with Gyproc.

**NB** The maximum substantiated span on the above solid timber joist systems is 4000mm. For any spans greater than this please contact our Technical Department.



## GypFloor SILENT performance (continued)

### Installed to existing solid timber joists (ceiling retained)

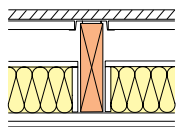
For details of when to specify fire resistance using BS

▶ Refer to C02, S01, P18



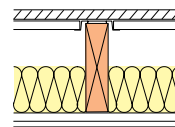
Table 2 — Solutions to satisfy requirements of BS 476: Part 21: 1987

①



**GypFloor SILENT** comprising Gyproc Plank on Gyproframe SIF Floor Channel located over timber joists. Walking surface of chipboard or softwood flooring (21mm minimum t&g). Cavity bridged between joists (minimum joist width 50mm) by 12.5mm Glasroc F MULTIBOARD resting on 100mm x 12.5mm Glasroc F MULTIBOARD strips (screw-fixed to joists flush with bottom edge, at 300mm centres). 100mm Isover Spacesaver Ready-Cut in the cavity. Existing ceiling linings as in table.

②



**GypFloor SILENT** comprising Gyproc Plank on Gyproframe SIF Floor Channel located over timber joists. Walking surface of chipboard or softwood flooring (21mm minimum square edge). 100mm Isover Spacesaver Ready-Cut in the cavity. Ceiling linings as in table.

Detail	Ceiling lining	Ceiling depth mm	Lining thickness mm	Sound insulation		System reference
				Airborne $R_w$ dB	Impact $L_{n,w}$ dB	
<b>30 minutes fire resistance</b> (BS)						
②	Gyproc Plank + Gyproc WallBoard	31.5	1 x 19 + 1 x 12.5	54	63	C204004
②	Existing plasterboard + Gyproc SoundBloc overboarding	25	1 x 12.5 + 1 x 12.5	54	63	C204005
<b>60 minutes fire resistance</b> (BS)						
①	Gyproc Plank + Gyproc WallBoard <sup>1,2</sup>	31.5	1 x 19 + 1 x 12.5	54	63	G104032
②	Existing plasterboard + Gyproc FireLine overboarding	27.5	1 x 12.5 + 1 x 15	54	63	C204007

▶ For further assistance in choosing the right solution for your project, try our System Selector; an online tool that enables quick and easy filtering by performance criteria. It provides system specific information downloads including BIM (Revit) objects. Go to [gyproc.ie](http://gyproc.ie)

<sup>1</sup> Linings used in acoustic tests to simulate a lath and plaster ceiling in good condition.

<sup>2</sup> The performance was achieved with t&g flooring. For non t&g floors, overlay with 6mm plywood and ensure all joints are staggered.

**(NB)** The fire resistance and sound insulation performances are for imperforate partitions, walls and ceilings incorporating boards with all joints taped and filled, or skimmed according to Gyproc's recommendations. The quoted performances are achieved only if Gyproc and Isover components are used throughout, and the Company's fixing recommendations are strictly observed. Any variation in the specification should be checked with Gyproc.

**(NB)** For non t&g floors, overlay with 6mm plywood and ensure all joints are staggered.

# GypFloor SILENT design

## Building design

GypFloor SILENT comprises Gypframe SIF Floor Channels positioned on the upper surface of the timber joists and Gypframe RB1 Resilient Bars fixed to the under side of the timber joists.

## Planning – key factors

The GypFloor SILENT system adds 7mm to the level of the top of the joists. The finished surface of the applied ceiling linings will be 16mm plus the thickness of the lining boards from the underside of the joists when Gypframe RB1 Resilient Bar is used. Ceiling linings should be fixed prior to any installation of drylining or plastering on walls. If this is not possible, ceiling linings should neatly abut the wall.

In refurbishment work the level of existing joists should be checked. Their upper surfaces should be reasonably level and straight for the flooring application. If there is misalignment of their lower surfaces, consideration should be given to using a Gyplyner or CasoLine MF suspended ceiling to support the ceiling boards.

## Structural

The system is primarily intended for timber floors with an intensity of distributed load of up to 5.0kN/m<sup>2</sup>, and a point load of 4.5kN. An increase in the mass of the floor will result from upgrading. The load capacity of the supporting floor joists should therefore be checked, with due consideration to the effects of lateral buckling and the need for intermediate restraints. This may be particularly important where the system is to be used in conjunction with engineered timber 'T' joists.

## Flanking transmission

Care should be taken to ensure that the associated structure is suitable to achieve the level of sound insulation required. Particular reference to Building Regulations (See section C02. S01. P21) should be made as regards the use of this floor type and the requirements of the surrounding structure. Where the walls supporting the floor weigh less than 365kg/m<sup>2</sup> the use of an acoustic shield lining to the walls should be considered.

## Existing plaster and lath ceilings

In order to ensure the required fire resistance of a floor is achieved, it is recommended to under-draw the lath and plaster with chicken wire (fixed in accordance with manufacturer recommendations). A cavity should then be formed with minimum 38 x 38mm timber battens or Gyplyner.

## Services

The installation of services within the floor zone should be carried out to allow easy access from above and should, where possible, follow the line of the floor joists.

## Board finish

▶ Refer to C08. S01. P483 – Finishes.



## Handy hint

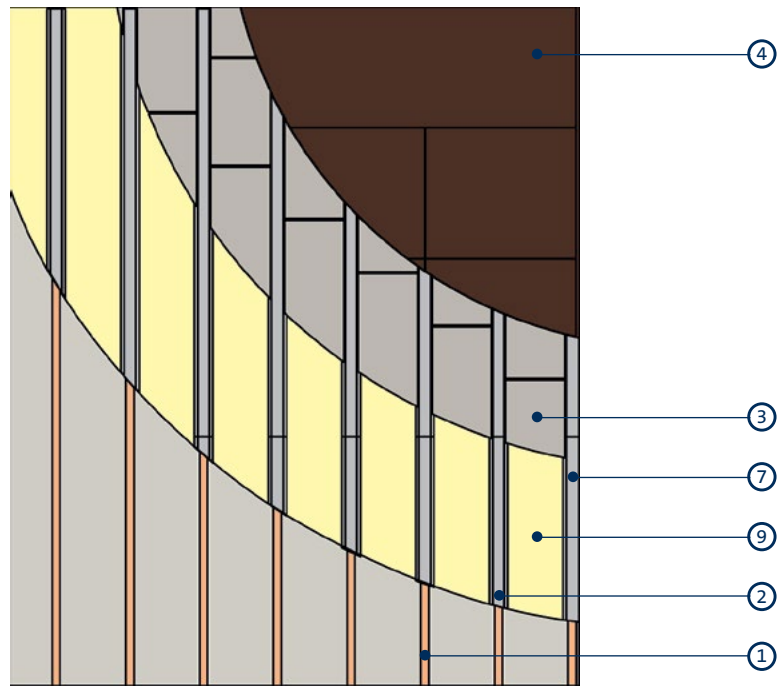
Gypframe SIF Floor Channels can accommodate a wide range of joist widths:

- Gypframe SIF1 Floor Channel for joists ≤63mm
- Gypframe SIF4 Floor Channel for joists 64 - 75mm
- Gypframe SIF2 Floor Channel for joists ≥75mm

**NB** Ensure that channels are never fixed to the joist.

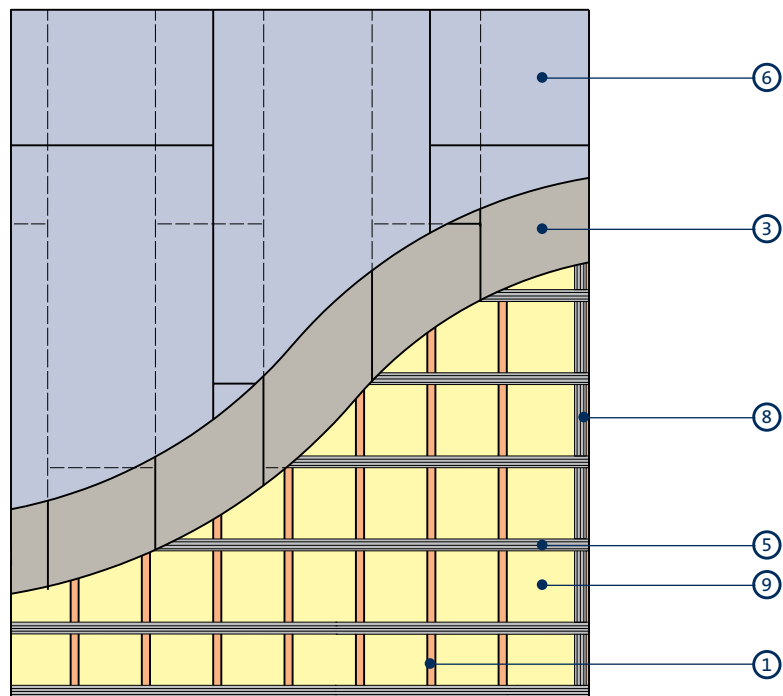
# GypFloor SILENT construction details

1



Cut-away floor plan (Chipboard flooring)

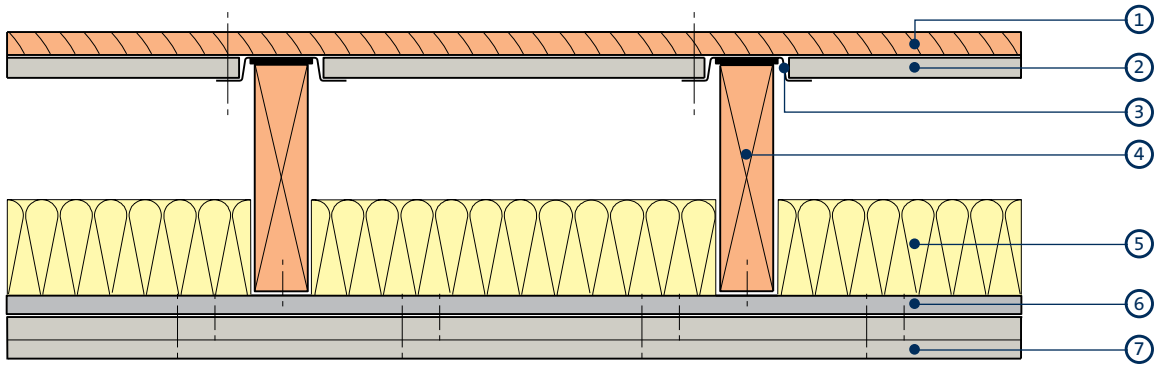
2



Reflected ceiling plan (12.5mm x 1200mm x 2700mm Gyproc SoundBloc over Gyproc Plank fixed to Gypframe RB1 Resilient Bars)

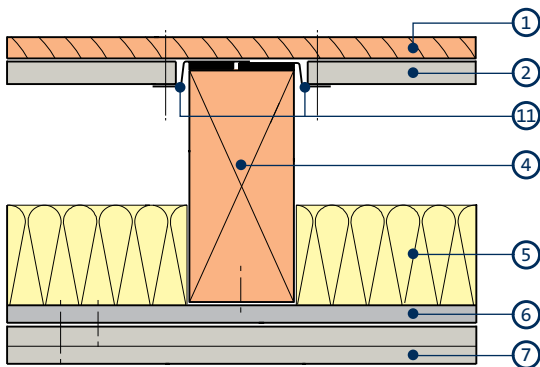
- |                               |   |
|-------------------------------|---|
| 1 Solid timber joists         | 6 Gyproc SoundBloc                                      |
| 2 Gypframe SIF Floor Channels | 7 Gypframe SIF2 Floor Channel                           |
| 3 Gyproc Plank                | 8 Gypframe RB1 Resilient Bar noggings at room perimeter |
| 4 Chipboard flooring          | 9 Isover Spacesaver Ready-Cut                           |
| 5 Gypframe RB1 Resilient Bar  |   |

3



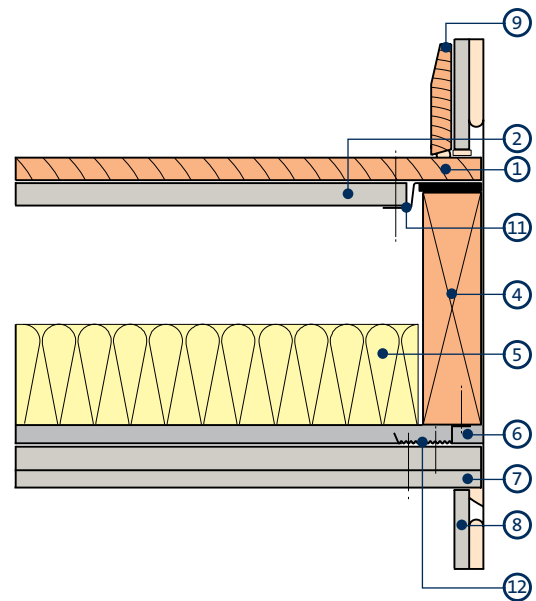
Typical section through floor

4



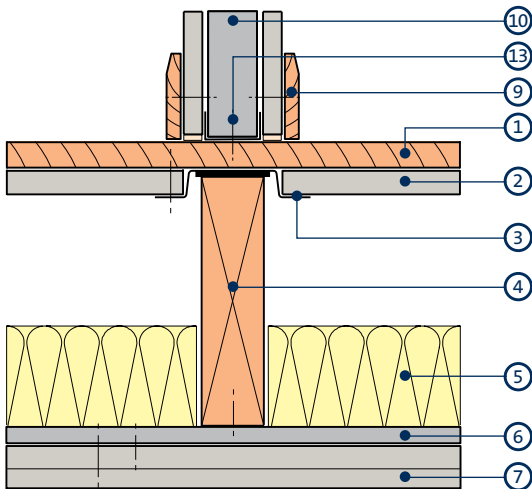
Section through floor - joist width over 75mm

5



Perimeter junction - inner leaf of external wall exceeds mass of 365kg/m<sup>2</sup>

6



Non-loadbearing partition sited over joists

1 Chipboard / softwood flooring

2 Gyproc Plank

3 Gypframe SIF1 / SIF4 Floor Channel

4 Solid timber joist

5 100mm Isover Spacesaver Ready-Cut

6 Gypframe RB1 Resilent Bars<sup>1</sup>

7 Gyproc plasterboard

8 Wall lining

9 Skirting

10 GypWall partition (low acoustic)

11 Gypframe SIF2 Floor Channel

12 Gypframe RB1 Resilient Bar noggings

13 Fixing length selected to avoid reaching the Gypframe SIF1 Floor Channel

<sup>1</sup> Alternatively, a Gyplyner ceiling system may be specified.

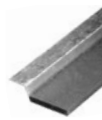
# GypFloor SILENT system components

## Gypframe metal components



### Gypframe SIF1 Floor Channel

Channel, with integral acoustic isolator, laid on top of timber joists less than or equal to 63mm wide to support Gyproc Plank.



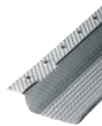
### Gypframe SIF2 Floor Channel

Channel, with integral acoustic isolator, laid on top of timber joists greater than 75mm wide to support Gyproc Plank. Also used around perimeter.



### Gypframe SIF4 Floor Channel

Channel, with integral acoustic isolator, laid on top of timber joists between 64mm and 75mm wide to support Gyproc Plank.



### Gypframe RB1 Resilient Bar

Acoustically engineered channel to separate board fixing from the timber joist and to overcome nail popping. Fixed to underside of joists.

## Board products



### Gyproc WallBoard

Standard gypsum plasterboard.



### Gyproc FireLine<sup>1</sup>

Gypsum plasterboard with fire resistant additives.



### Gyproc Plank

Standard gypsum plasterboard located as an inner layer and / or located within Gypframe floor channels.



### Glasroc F MULTIBOARD

Non-combustible glass-reinforced gypsum board.



### Gyproc SoundBloc<sup>1</sup>

Gypsum plasterboard with a high density core for enhanced sound insulation performance.

<sup>1</sup> Also available in Moisture Resistant (MR) version. MR boards are specified in intermittent wet use areas.

## Fixing products



### Gyproc Drywall Screws

Corrosion resistant self-tapping steel screws for fixing board-to-timber and board-to-metal framing less than 0.8mm thick.



### Gyproc Collated Drywall Screws

Corrosion resistant self-tapping steel screws for fixing board-to-timber and board-to-metal framing less than 0.8mm thick.



### GypFloor SIF5 Floor Screws

For fixing floorboards through Gyproc Plank into the Gypframe Floor Channel flange.

## GypFloor SILENT system components (continued)

### Plasterboard accessories



#### Gyproc Jointing Materials

Jointing compounds, ready mixes and adhesives for reinforcement and finishing of board joints.



#### Gyproc Drywall Primer

Used to prepare for painting.  
Tub contents 10 litre



#### Gyproc Sealant

Used to seal air paths for optimum sound insulation.



#### Gyproc Paper Joint Tape

A paper tape designed for reinforcement of flat joints or internal angles.

### Plaster products



#### Gyproc Skimcoat

To provide a plaster skim finish on most common backgrounds including undercoat plasters and plasterboard. Can provide enhanced acoustic performance.



#### Gyproc Carlite Finish

To provide a plaster skim finish on most common backgrounds including undercoat plasters and plasterboard. Can provide enhanced acoustic performance.



#### Gyproc Carlite Ultra Finish

Offers all the benefits of Gyproc Skimcoat and Gyproc Carlite Finish with a reduced set time of 90-120mins, making it ideal for smaller jobs.



#### Plaster accessories

Designed for the reinforcement and finishing of board joints before plaster skimming.



#### Gyproc Bonding Coat

A lightweight undercoat plaster for use over smooth or medium suction backgrounds. Applied at a depth of 10mm on walls or 8mm on ceilings. Bonding Coat Short Set also available with a reduced set time of 90-120 mins making it ideal for smaller jobs.

### Insulation products



#### Isover Spacesaver Ready-Cut

Glass mineral wool for enhanced acoustic and thermal performance.

## GypFloor SILENT installation overview

This is intended to be a basic description of how the system is built.



Gypframe SIF Floor Channels are located centrally over the joists. They must not be fixed to the joists.



Gyproc Plank is cut neatly to fit between the channels.



Flooring is laid across the Gypframe SIF Floor Channels and screw-fixed through the Gyproc Plank to the channel flange on one side only, using Gypframe SIF5 Floor Screws. It is important to ensure that no fixings are allowed to connect the Gypframe SIF Floor Channels to the joists.



Gypframe RB1 Resilient Bars are installed to the underside of the joists with Gyproc Drywall Screws.



100mm Isover Spacesaver Ready-Cut is laid between joists to rest on the Gypframe RB1 Resilient Bars. The specified ceiling boards are then screw fixed to the Gypframe RB1 Resilient Bars with the correct length Gyproc Drywall Screws to ensure the screws do not contact the timber joists.



### Additional information

For full installation details, refer to the [Gyproc Installation Guide](#), available to download from [gyproc.ie](http://gyproc.ie)



# Loadbearing timber joist floors

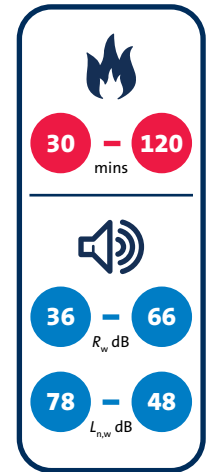
Internal and separating floor systems



## Loadbearing timber joist floors

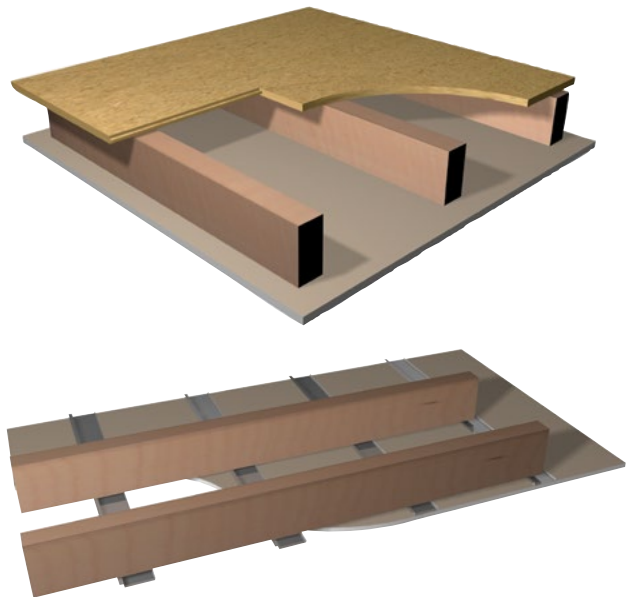
Timber joists are widely used within internal floor and separating floor construction, both in residential and commercial applications.

Our range of timber joist floor solutions include cavity insulation, high-performance Gyproc plasterboards and Gypframe sound insulating bars. Our solutions maximise acoustic and fire performance, to both meet, and significantly exceed, the requirements of Building Regulations, for new build and refurbishment projects.



### Key benefits

- When Gyproc plasterboards are directly fixed, defects are minimised using Gyproc Drywall Screws
- Nail popping is eliminated through the use of Gypframe RB1 Resilient Bar
- Significantly enhanced acoustic performance is achieved when Gypframe RB1 Resilient Bar is specified alongside Gyproc SoundBloc plasterboard linings



### You may also be interested in...

#### CasoLine MF

A suspended ceiling system, capable of providing up to 120 minutes fire resistance. Suitable for internal drylining application to timber joist floors. The fully concealed grid and ceiling lining can be used in conjunction with Gyproc plasterboards and Gyptone or Rigitone acoustic ceiling boards to create a seamless, monolithic appearance.

► Refer to C06. S02. P355 – CasoLine MF.

# Loadbearing timber joist floors performance

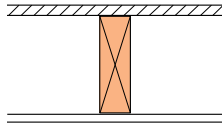
## Ceiling directly fixed to new or existing solid timber joist floors

For details of when to specify fire resistance using EN  
 ▶ Refer to C02. S01. P18



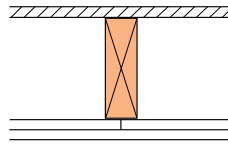
Table 1a - Solutions to satisfy requirements of BS EN 1365-2: 2000

①



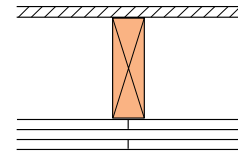
22mm t&g<sup>1</sup> (softwood or chipboard) floor boarding over minimum 195mm x 38mm timber joists at 600mm centres. Noggings and linings as in table.

②



22mm t&g<sup>1</sup> (softwood or chipboard) floor boarding over minimum 195mm x 38mm timber joists at 600mm centres. Noggings and linings as in table.

③



22mm t&g<sup>1</sup> (softwood or chipboard) floor boarding over minimum 195mm x 38mm timber joists at 600mm centres (maximum). Noggings and linings as in table.

Detail	Nominal floor depth mm	Board type	Ceiling lining thickness mm	Noggings required	Maximum loadbearing ratio	Sound insulation		System reference
						Airborne $R_w$ dB	Impact $L_{n,w}$ dB	
<b>30 minutes fire resistance</b>								
①	227	Glasroc F MULTIBOARD	1 x 10	Yes <sup>2</sup>	100%	-	-	G106036
①	232	Gyproc WallBoard	1 x 15	Yes <sup>3</sup>	100%	40	-	C106029
<b>60 minutes fire resistance</b>								
②	237	Glasroc F MULTIBOARD	2 x 10	Yes <sup>2</sup>	100%	-	-	G106022
②	242	Gyproc FireLine	2 x 12.5	Yes <sup>2</sup>	100%	40	76	C016009
②	245	Gyproc WallBoard (inner layer) + Gyproc FireLine (outer layer)	1 x 12.5 + 1 x 15	Yes <sup>3</sup>	100%	40	76	C016008
<b>90 minutes fire resistance</b>								
③	255	Gyproc FireLine	3 x 12.5	Yes <sup>2</sup>	100%	40	-	C016012

▶ For further assistance in choosing the right solution for your project, try our System Selector; an online tool that enables quick and easy filtering by performance criteria. It provides system specific information downloads including BIM (Revit) objects. Go to [gyproc.ie](http://gyproc.ie)

<sup>1</sup> For non t&g floors, overlay with 6mm plywood and ensure all joints are staggered.

<sup>2</sup> At ceiling perimeter and to support outer layer ceiling board joints (38mm x 38mm minimum).

<sup>3</sup> At ceiling perimeter only.

**NB** The fire resistance and sound insulation performances are for imperforate partitions, walls and ceilings incorporating boards with all joints taped and filled, or skimmed according to Gyproc's recommendations. The quoted performances are achieved only if Gyproc and Isover components are used throughout, and the Company's fixing recommendations are strictly observed. Any variation in the specifications should be checked with Gyproc.

**NB** Where boards are fixed direct to timber joists, Gyproc Drywall Screws should be used as opposed to nail-fixing to minimise the risk of fixing defects occurring.

**NB** The maximum substantiated span on the above solid timber joist systems is 4000mm. For any spans greater than this please contact our Technical Department.



### Handy hint

For further information regarding Building Regulations acoustic performance requirements.

▶ Refer to C02. S01. P21 – Building acoustics

# Loadbearing timber joist floors performance (continued)

## Ceiling directly fixed to new or existing solid timber joist floors

For details of when to specify fire resistance using BS  
Refer to C02. S01. P18



Table 1b - Solutions to satisfy the requirements of BS 476: Part 21: 1987

①		②		③		④	
	22mm t&g <sup>1</sup> (softwood or chipboard) floor boarding over minimum 195mm x 38mm timber joists at 600mm centres. Noggings and linings as in table.		22mm t&g <sup>1</sup> (softwood or chipboard) floor boarding over minimum 195mm x 38mm timber joists at 450mm centres. Noggings and linings as in table.		22mm t&g <sup>1</sup> (softwood or chipboard) floor boarding over minimum 195mm x 38mm timber joists at 600mm centres. Noggings and linings as in table.		22mm t&g <sup>1</sup> (softwood or chipboard) floor boarding over minimum 195mm x 38mm timber joists at 450mm centres. Noggings and linings as in table.
⑤		⑥					
	22mm t&g <sup>1</sup> (softwood or chipboard) floor boarding over minimum 195mm x 50mm timber joists at 450mm centres. Noggings and linings as in table.		22mm t&g <sup>1</sup> (softwood or chipboard) floor boarding over minimum 241mm timber 'I' joists at 600mm centres. Noggings and linings as in table.				

Detail	Nominal floor depth mm	Board type	Ceiling lining thickness mm	Noggings required	Maximum loadbearing ratio	Sound insulation		System reference
						Airborne $R_w$ dB	Impact $L_{n,w}$ dB	
<b>30 minutes fire resistance (BS)</b>								
②	230	Gyproc WallBoard	1 x 12.5	Yes <sup>2</sup>	60%	36	-	C014003
①	230	Gyproc FireLine	1 x 12.5	Yes <sup>3</sup>	60%	38	-	C016004
①	232	Gyproc WallBoard	1 x 15	Yes <sup>2</sup>	100%	40	-	C106029
⑥	278	Gyproc WallBoard	1 x 15	Yes <sup>2</sup>	60% <sup>4</sup>	41	-	C206015
<b>60 minutes fire resistance (BS)</b>								
③	242	Gyproc FireLine	2 x 12.5	Yes <sup>3</sup>	100%	40	76	C016009
④	245	Gyproc WallBoard (inner layer) + Gyproc FireLine (outer layer)	1 x 12.5 + 1 x 15	Yes <sup>2</sup>	100%	40	76	C016008
⑤	247	Gyproc WallBoard	2 x 15	Yes <sup>3</sup>	60%	40	76	C016006
⑤	249	Gyproc Plank (inner layer) + Gyproc WallBoard (outer layer)	1 x 19 + 1 x 12.5	Yes <sup>2</sup>	60%	40	75	C016007
<b>90 minutes fire resistance (BS)</b>								
⑤	247	Gyproc FireLine	2 x 15	Yes <sup>3</sup>	60%	40	78	C014011

► For further assistance in choosing the right solution for your project, try our System Selector; an online tool that enables quick and easy filtering by performance criteria. It provides system specific information downloads including BIM (Revit) objects. Go to [gyproc.ie](http://gyproc.ie)

<sup>1</sup>For non t&g floors, overlay with 6mm plywood and ensure all joints are staggered.

<sup>2</sup>At ceiling perimeter only.

<sup>3</sup>At ceiling perimeter and to support outer layer ceiling board joints.

<sup>4</sup>This value is based on a test with a typical 'I' joist. Consult manufacturers directly for information on specific 'I' joists.

**(NB)** The fire resistance and sound insulation performances are for imperforate partitions, walls and ceilings incorporating boards with all joints taped and filled, or skimmed according to Gyproc's recommendations. The quoted performances are achieved only if Gyproc and Isover components are used throughout, and the Company's fixing recommendations are strictly observed. Any variation in the specifications should be checked with Gyproc.

**(NB)** Where boards are fixed direct to timber joists, Gyproc Drywall Screws should be used as opposed to nail-fixing to minimise the risk of fixing defects occurring.

**(NB)** All the 30 and 60 minute specifications in table 1b can be used on the underside of an existing lath and plaster ceiling provided the existing ceiling is supported by chicken wire securely fixed to the joists and counter battened with minimum 38mm x 38mm timber at 600mm centres, with noggings to support the long edges of the outer layer board.

## Loadbearing timber joist floors performance (continued)

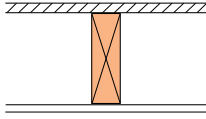
### Non-combustible ceiling linings directly fixed to new or existing solid timber joist floors

For details of when to specify fire resistance using BS  
 ▶ Refer to C02. S01. P18



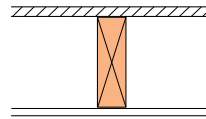
Table 2 – Solutions to satisfy the requirements of BS 476: Part 21: 1987

①



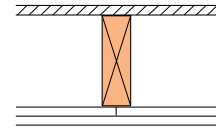
18mm t&g<sup>1</sup> (softwood or chipboard) floor boarding over minimum 195mm x 38mm timber joists at 450mm centres with suitable noggings between joists to support board edges. Linings as in table.

②



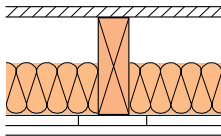
22mm t&g<sup>1</sup> (softwood or chipboard) floor boarding over minimum 195mm x 38mm timber joists at 600mm centres with suitable noggings between joists to support board edges. Linings as in table.

③



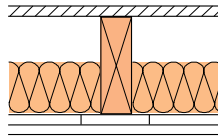
22mm t&g<sup>1</sup> (softwood or chipboard) floor boarding over minimum 195mm x 47mm timber joists at 600mm centres with suitable noggings between joists to support board edges. Linings as in table.

④



18mm t&g<sup>1</sup> (softwood or chipboard) floor boarding over minimum 195mm x 50mm timber joists at 400mm centres. 30mm stone mineral wool (64kg/m<sup>3</sup>) in the cavity. Linings as in table.

⑤



22mm t&g<sup>1</sup> (softwood or chipboard) floor boarding over minimum 195mm x 50mm timber joists at 600mm centres with suitable noggings between joists to support board edges. 60mm stone mineral wool (23kg/m<sup>3</sup>) in the cavity. Linings as in table.

Detail	Nominal floor depth mm	Board type	Ceiling lining thickness mm	Noggings required	System reference
<b>30 minutes fire resistance</b>					
①	219	Glasroc F MULTIBOARD	1 x 6	Yes <sup>3</sup>	G104019
②	227	Glasroc F MULTIBOARD	1 x 10	Yes <sup>3</sup>	G106036
②	230	Glasroc F MULTIBOARD	1 x 12.5	Yes <sup>3</sup>	G106021
<b>60 minutes fire resistance</b>					
②	232	Glasroc F FIRECASE (screw-fixed) <sup>2</sup>	1 x 15	Yes <sup>3</sup>	G106025
④	233	80mm wide Glasroc F MULTIBOARD strip + Glasroc F MULTIBOARD	1 x 10 + 1 x 10	No	G104024
③	237	Glasroc F MULTIBOARD	2 x 10	Yes <sup>3</sup>	G106022
⑤	237	80mm wide Glasroc F MULTIBOARD strip + Glasroc F MULTIBOARD	1 x 10 + 1 x 10	Yes <sup>3</sup>	G106046

▶ For further assistance in choosing the right solution for your project, try our System Selector; an online tool that enables quick and easy filtering by performance criteria. It provides system specific information downloads including BIM (Revit) objects. Go to [gyproc.ie](http://gyproc.ie)

<sup>1</sup> For non t&g floors, overlay with 6mm plywood and ensure all joints are staggered.

<sup>2</sup> Use 58mm Glasroc F FIRECASE Screws at 150mm centres, and increase the width of the timber joists at the location of board ends using 25mm x 25mm timber battens.

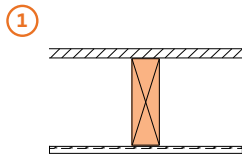
<sup>3</sup> At ceiling perimeter and to support outer layer ceiling board joints (38mm x 38mm minimum).

**NB** The fire resistance and sound insulation performances are for imperforate partitions, walls and ceilings incorporating boards with all joints taped and filled, or skimmed according to Gyproc's recommendations. The quoted performances are achieved only if Gyproc and Isover components are used throughout, and the Company's fixing recommendations are strictly observed. Any variation in the specifications should be checked with Gyproc.

**NB** Where boards are fixed direct to timber joists, Gyproc Drywall Screws should be used as opposed to nail-fixing to minimise the risk of fixing defects occurring.



Table 3 – Solutions to satisfy the requirements of BS 476: Part 21: 1987



21mm t&g (softwood or chipboard) floor boarding over timber joists at 600mm centres with suitable timber noggings between joists to support metal lathing. Plaster to metal lathing as in table.

Detail	Ceiling specification	Joist centres	Joist width (minimum) mm	System reference
<b>60 minutes fire resistance</b> (BS)				
1	Ribbed metal lath <sup>1</sup> with 13mm Gyproc Bonding Coat and 2mm Gyproc Finish Plaster	600	44	C016016
<b>120 minutes fire resistance</b> (BS)				
1	Ribbed metal lath <sup>1</sup> with 19mm Gyproc Bonding Coat and 2mm Gyproc Finish Plaster	600	48	C016045

► For further assistance in choosing the right solution for your project, try our System Selector; an online tool that enables quick and easy filtering by performance criteria. It provides system specific information downloads including BIM (Revit) objects. Go to [gyproc.ie](http://gyproc.ie)

<sup>1</sup> Where plaster is applied to ribbed metal lath, the plaster thickness is measured from the face of the lath, and the lath should be installed in accordance with the manufacturers' recommendations. With 120 minutes fire resistance construction, the metal lath is independently fixed with wire supports from the joist sides. Refer to C07. S02. P438 – Plaster systems, design, How to apply plaster to metal lath.

**(NB)** Gyproc plaster is classified A1 in accordance with BS EN 13501-1: 2002.

## Loadbearing timber joist floors performance (continued)

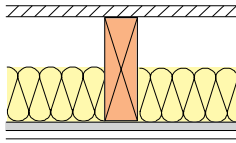
### Ceiling indirectly fixed to new or existing solid timber joist floors

For details of when to specify fire resistance using EN  
 Refer to C02. S01. P18



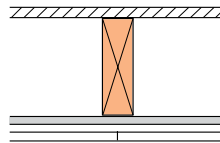
Table 4a - Solutions to satisfy the requirements of BS EN 1365-2: 2000

①



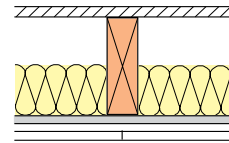
22mm t&g<sup>1</sup> (softwood or chipboard) floor boarding over minimum 195mm x 38mm timber joists at 600mm centres. Gypframe RB1 Resilient Bars fixed to underside of joists at 450mm centres and at perimeter with ceiling linings as in table fixed into the bars only. 100mm Isover Acoustic Roll in the cavity.

②



22mm t&g<sup>1</sup> (softwood or chipboard) floor boarding over minimum 195mm x 38mm timber joists at 600mm centres. Gypframe RB1 Resilient Bars fixed to underside of joists at 450mm centres and at perimeter with ceiling linings as in table fixed into the bars only.

③



22mm t&g<sup>1</sup> (softwood or chipboard) floor boarding over minimum 195mm x 38mm timber joists at 600mm centres. Gypframe RB1 Resilient Bars fixed to underside of joists at 450mm centres and at perimeter with ceiling linings as in table fixed into the bars only. 100mm Isover Spacesaver Ready-Cut in the cavity.

Detail	Nominal floor depth mm	Board type	Ceiling lining thickness mm	Maximum loadbearing ratio	Sound insulation		System reference
					Airborne $R_w$ dB	Impact $L_{n,w}$ dB	
<b>30 minutes fire resistance</b>							
①	240	Gyproc WallBoard	1 x 12.5	100%	41	76	C206006
<b>60 minutes fire resistance</b>							
②	258	Gyproc FireLine	2 x 12.5	100%	45	72	C016031
③	263	Gyproc SoundBloc	2 x 15	100%	54	60	C206009

► For further assistance in choosing the right solution for your project, try our System Selector; an online tool that enables quick and easy filtering by performance criteria. It provides system specific information downloads including BIM (Revit) objects. Go to [gyproc.ie](http://gyproc.ie)

<sup>1</sup> For non t&g floors, overlay with 6mm plywood and ensure all joints are staggered.

**NB** The fire resistance and sound insulation performances are for imperforate partitions, walls and ceilings incorporating boards with all joints taped and filled, or skimmed according to Gyproc's recommendations. The quoted performances are achieved only if Gyproc and Isover components are used throughout, and the Company's fixing recommendations are strictly observed. Any variation in the specifications should be checked with Gyproc.

**NB** Where boards are fixed direct to timber joists, Gyproc Drywall Screws should be used as opposed to nail-fixing to minimise the risk of fixing defects occurring.

**NB** The maximum substantiated span on the above solid timber joist systems is 4000mm. For any spans greater than this please contact our Technical Department.

## Loadbearing timber joist floors performance (continued)

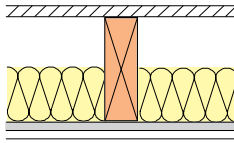
### Ceiling indirectly fixed to new or existing solid timber joist floors

For details of when to specify fire resistance using BS  
 Refer to C02. S01. P18



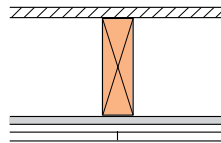
Table 4b - Solutions to satisfy requirements of BS 476: Part 21: 1987

①



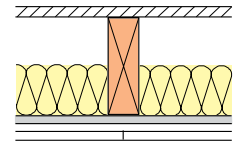
22mm t&g<sup>1</sup> (softwood or chipboard) floor boarding over minimum 195mm x 38mm timber joists at 600mm centres.  
 Gypframe RB1 Resilient Bars fixed to underside of joists at 450mm centres and at perimeter with ceiling linings as in table fixed into the bars only. 100mm Isover Acoustic Roll in the cavity.

②



22mm t&g<sup>1</sup> (softwood or chipboard) floor boarding over minimum 195mm x 38mm timber joists at 600mm centres.  
 Gypframe RB1 Resilient Bars fixed to underside of joists at 450mm centres and at perimeter with ceiling linings as in table fixed into the bars only.

③



22mm t&g<sup>1</sup> (softwood or chipboard) floor boarding over minimum 195mm x 38mm timber joists at 600mm centres.  
 Gypframe RB1 Resilient Bars fixed to underside of joists at 450mm centres and at perimeter with ceiling linings as in table fixed into the bars only. 100mm Isover Spacesaver Ready-Cut in the cavity.

Detail	Nominal floor depth mm	Board type	Ceiling lining thickness mm	Maximum loadbearing ratio	Sound insulation		System reference
					Airborne $R_w$ dB	Impact $L_{n,w}$ dB	
<b>30 minutes fire resistance</b> (BS)							
①	240	Gyproc WallBoard	1 x 12.5	100%	41	76	C206006
<b>60 minutes fire resistance</b> (BS)							
②	258	Gyproc FireLine	2 x 12.5	100%	45	72	C016031
③	263	Gyproc SoundBloc	2 x 15	100%	54	60	C206009

► For further assistance in choosing the right solution for your project, try our System Selector; an online tool that enables quick and easy filtering by performance criteria. It provides system specific information downloads including BIM (Revit) objects. Go to [gyproc.ie](http://gyproc.ie)

<sup>1</sup>For non t&g floors, overlay with 6mm plywood and ensure all joints are staggered.

**(NB)** The fire resistance and sound insulation performances are for imperforate partitions, walls and ceilings incorporating boards with all joints taped and filled, or skimmed according to Gyproc's recommendations. The quoted performances are achieved only if Gyproc and Isover components are used throughout, and the Company's fixing recommendations are strictly observed. Any variation in the specifications should be checked with Gyproc.

**(NB)** Where boards are fixed direct to timber joists, Gyproc Drywall Screws should be used as opposed to nail-fixing to minimise the risk of fixing defects occurring.

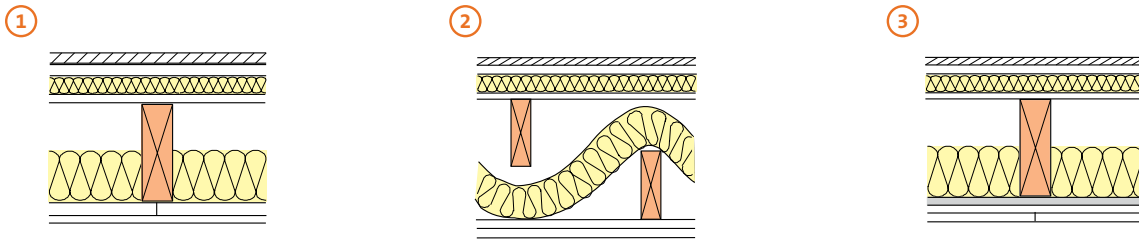
## Loadbearing timber joist floors performance (continued)

### Compartment / separating solid timber joist and sub-joist floors

For details of when to specify fire resistance using BS  
 ▶ Refer to C02. S01. P18



Table 5 - Solutions to satisfy requirements of BS 476: Part 21: 1987



Typical platform floor construction (comprising walking surface of 18mm t&g<sup>1</sup> wood board flooring, spot-bonded with Gyproc Sealant at 300mm centres to a substrate of Gyproc Plank laid on 25mm Isover Sound Deadening Floor Slab, laid on a minimum of 12mm wood-based sheet sub-deck nailed to the joists) over 195mm x 44mm timber joists at 600mm centres. 100mm Isover Acoustic Roll between the joists. Linings as in table.

Separating sub-joist floor comprising of a platform floor construction (comprising walking surface of 18mm t&g<sup>1</sup> wood board flooring, spot-bonded with Gyproc Sealant at 300mm centres to a substrate of Gyproc Plank laid on 25mm Isover Sound Deadening Floor Slab, laid on a minimum of 12mm wood-based sheet sub-deck nailed to the joists) over minimum 47mm wide timber floor joists at 600mm centres. 100mm Isover Acoustic Roll in the cavity. Independent minimum 47mm wide ceiling joists. Linings as in table.

Typical platform floor construction (comprising walking surface of 18mm t&g<sup>1</sup> wood board flooring, spot-bonded with Gyproc Sealant at 300mm centres to a substrate of Gyproc Plank laid on 25mm Isover Sound Deadening Floor Slab, laid on a minimum of 12mm wood-based sheet sub-deck nailed to the joists) over minimum 195mm x 38mm timber joists at 600mm centres. Gyproframe RB1 Resilient Bars fixed to underside of joists at 450mm centres and at perimeter with ceiling. Linings as in table fixed into the bars only. 100mm Isover Spacesaver Ready-Cut in the cavity.

Detail	Nominal floor depth mm	Board type	Ceiling lining thickness mm	Maximum loadbearing ratio	Sound insulation		System reference
					Airborne $R_w (R_w + C_{tr})$ dB	Impact $L_{n,w}$ dB	
<b>60 minutes fire resistance</b>							
①	301	Gyproc Plank (inner layer) + Gyproc SoundBloc (outer layer)	1 x 19 + 1 x 12.5	100%	62 (50)	56	C016038
③	315	Gyproc SoundBloc	2 x 15	100%	64 (53) <sup>2</sup>	54	C016040
②	320	Gyproc SoundBloc	2 x 15	100%	66 (55) <sup>2</sup>	48	C106050

▶ For further assistance in choosing the right solution for your project, try our System Selector; an online tool that enables quick and easy filtering by performance criteria. It provides system specific information downloads including BIM (Revit) objects. Go to [gyproc.ie](http://gyproc.ie)

<sup>1</sup> For non t&g floors, overlay with 6mm plywood and ensure all joints are staggered.

<sup>2</sup> These Gyproc Approved Systems are designed to achieve minimum  $D_{nT,w} + C_{tr}$  45dB and  $L'_{nT,w}$  62dB subject to Pre-Completion Testing.

**NB** Separating floors require both a suitable isolating floor and a suitable isolating ceiling.

**NB** The fire resistance and sound insulation performances are for imperforate partitions, walls and ceilings incorporating boards with all joints taped and filled, or skimmed according to Gyproc's recommendations. The quoted performances are achieved only if Gyproc and Isover components are used throughout, and the Company's fixing recommendations are strictly observed. Any variation in the specifications should be checked with Gyproc.

**NB** Where boards are fixed direct to timber joists, Gyproc Drywall Screws should be used as opposed to nail-fixing to minimise the risk of fixing defects occurring.

## Loadbearing timber joist floors performance (continued)

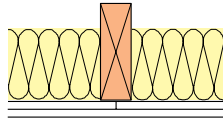
### Non-loadbearing ceiling directly fixed to joists

For details of when to specify fire resistance using EN  
 ▶ Refer to C02. S01. P18



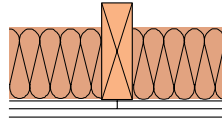
Table 6a - Solutions to satisfy the requirements of BS EN 1364-2: 1999

①



150mm x 38mm (minimum) joists (not roof trusses) at 600mm (maximum) centres. Insulation and ceiling linings as in table.

②



150mm x 38mm (minimum) joists (not roof trusses) at 600mm (maximum) centres. Insulation and ceiling linings as in table.

ROI Building Regulation guidance for new build dwellings requires fire rated solutions for truss rafters to be substantiated as load-bearing constructions.  
 Please contact our Technical Department on 1800 744480 for further assistance.

Detail	Board type	Ceiling lining thickness mm	Noggings required	Insulation type	System reference
<b>30 minutes fire resistance</b> <span style="border: 1px solid black; border-radius: 50%; padding: 2px;">EN</span>					
①	Gyproc WallBoard	2 x 15	Yes <sup>1</sup>	150mm Isover Spacesaver Ready-Cut	C106052
①	Gyproc FireLine	2 x 12.5	Yes <sup>1</sup>	150mm stone mineral wool (24kg/m <sup>3</sup> )	C106048
<b>60 minutes fire resistance</b> <span style="border: 1px solid black; border-radius: 50%; padding: 2px;">EN</span>					
②	Gyproc FireLine	2 x 15	Yes <sup>1</sup>	150mm stone mineral wool (24kg/m <sup>3</sup> )	C106059

▶ For further assistance in choosing the right solution for your project, try our System Selector; an online tool that enables quick and easy filtering by performance criteria. It provides system specific information downloads including BIM (Revit) objects. Go to [gyproc.ie](http://gyproc.ie)

<sup>1</sup> At ceiling perimeter and to support outer layer ceiling board joints.

**NB** The fire resistance and sound insulation performances are for imperforate partitions, walls and ceilings incorporating boards with all joints taped and filled, or skimmed according to Gyproc's recommendations. The quoted performances are achieved only if Gyproc and Isover components are used throughout, and the Company's fixing recommendations are strictly observed. Any variation in the specifications should be checked with Gyproc.

**NB** Where boards are fixed direct to timber joists, Gyproc Drywall Screws should be used as opposed to nail-fixing to minimise the risk of fixing defects occurring.

**NB** Timber Frame Circular No. 3 issued by the Building Standards (May 2020) requires that fire tests for fire rated trusses be undertaken on loaded construction, please contact the Technical Department for further information.

**NB** The maximum substantiated span on the above solid timber joist systems is 4000mm. For any spans greater than this please contact our Technical Department.

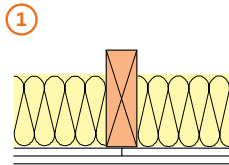
## Loadbearing timber joist floors performance (continued)

### Non-loadbearing ceiling directly fixed to joists

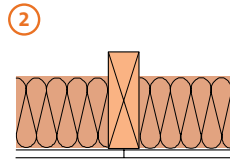
For details of when to specify fire resistance using BS  
 ▶ Refer to C02. S01. P18



Table 6b - Solutions to satisfy requirements of BS 476: Part 22: 1987



38mm (minimum) timber joists at 600mm centres, with suitable timber noggings between joists to support board edges. Insulation laid between joists (see table). Linings as in table.



38mm (minimum) timber joists at 600mm centres, with suitable timber noggings between joists to support board edges. Insulation laid between joists (see table). Linings as in table.

Detail	Board type	Ceiling lining thickness mm	Noggings required	Insulation type	System reference
<b>30 minutes fire resistance</b>					
1	Gyproc WallBoard	2 x 12.5	Yes <sup>1</sup>	150mm Isover Spacesaver Ready-Cut	C106049
2	Gyproc FireLine	2 x 12.5	Yes <sup>1</sup>	150mm stone mineral wool (24kg/m <sup>3</sup> )	C106048
<b>60 minutes fire resistance</b>					
1	Glasroc F MULTIBOARD	2 x 10	Yes <sup>1</sup>	150mm Isover Spacesaver Ready-Cut	G106042
2	Gyproc FireLine	2 x 15	Yes <sup>1</sup>	150mm stone mineral wool (24kg/m <sup>3</sup> )	C106059

▶ For further assistance in choosing the right solution for your project, try our System Selector; an online tool that enables quick and easy filtering by performance criteria. It provides system specific information downloads including BIM (Revit) objects. Go to [gyproc.ie](http://gyproc.ie)

<sup>1</sup> At ceiling perimeter and to support outer layer ceiling board joints.

**NB** The fire resistance and sound insulation performances are for imperforate partitions, walls and ceilings incorporating boards with all joints taped and filled, or skimmed according to Gyproc's recommendations. The quoted performances are achieved only if Gyproc and Isover components are used throughout, and the Company's fixing recommendations are strictly observed. Any variation in the specifications should be checked with Gyproc.

**NB** Where boards are fixed direct to timber joists, Gyproc Drywall Screws should be used as opposed to nail-fixing to minimise the risk of fixing defects occurring.

**NB** Timber Frame Circular No. 3 issued by the Building Standards (May 2020) requires that fire tests for fire rated trusses be undertaken on loaded construction, please contact the Technical Department for further information.

# Loadbearing timber joist floors design

## Planning – key factors

To minimise the risk of ceiling finish defects occurring, seasoned timber with a moisture content not exceeding that recommended in *BS 5268: Part 2: 2002* should be used. The contractor should ensure that timber supports are accurately spaced, aligned, and levelled. Gyproc Drywall Screws are the preferred method of fixing.



### Handy hint

For further information regarding Building Regulations acoustic performance requirements.

▶ Refer to C02. S01. P21 – Building acoustics.

## Cavity fire barriers

Cavity fire barriers may be required to satisfy the requirements of the Building Regulations.

▶ Refer to C06. S06. P422 – Cavity fire barriers.

## Strength and robustness

Timber should be aligned and level, and should meet the requirements of *BS 5268: Part 2: 2002*. The dimensions and assembly of timber supports should be sufficient to allow positive fixing of plasterboard without bounce or undue deflection because of screwing or other applied force. When the above fixing conditions cannot be met, a timber batten should be securely fixed to the side of the timber supports where ceiling boards butt, in order to increase the bearing surface.

Where boards are fixed at maximum centres in adverse conditions, the standard of lining can be affected. Adverse conditions can generally be described as conditions where high humidity occurs, principally in the cold, damp, autumn / winter period. They also refer to buildings under construction over this period, where both the structure and wet applications such as plastering and screeding are subject to slow drying conditions. In these adverse conditions there is a risk of the plasterboard bowing and therefore additional plasterboard support framing should be incorporated.

## Water vapour control

Where a vapour control layer is included in the ceiling construction in conditions described previously, condensation can form on the vapour control surface. This can result in plasterboard becoming unduly damp, and affecting the standard of acceptability of the lining and any applied plaster or textured coating. In these circumstances increased ventilation or dehumidification is recommended.

Where there is a requirement for a vapour control layer, DUPLEX grade Gyproc plasterboards should be specified as the face layer, i.e. the second layer in double layer linings. Isover Vario membranes will also provide vapour control.

Timber noggings should always be incorporated when fixing boards offering a vapour control layer, irrespective of joist spacing, e.g. DUPLEX grade Gyproc plasterboard and thermal laminates providing vapour control.

## Acoustic performance

Airtightness is essential for optimum sound insulation. While most junctions will be sealed with standard finishing materials, gaps at the perimeter of the floor and ceiling, and other small air paths, can be sealed using Gyproc Sealant. The performance of the floor in practice will generally be governed by flanking transmission.

▶ Refer to section C02. S01. P21 – Building acoustics.



### Important information

Impact sound insulation,  $L_{n,w}$  is a measurement of the amount of sound energy transmitted through the floor when tested under laboratory conditions. Therefore, the lower the figure, the better the performance.

## Imposed loads

The designer should ensure that the floor construction is suitable to support any imposed loads.

## Timber noggings within timber floors (direct fix applications)

Suitable timber noggings, typically 38mm x 38mm or 50mm x 50mm, may be required between joists and at the ceiling perimeter to support the edges / ends of the board. The provision of noggings depends on several factors; the thickness of the board, spacing of the timber joists and any technical performance requirements, e.g. vapour resistance and fire resistance performance. Table 7 below provides information on the general requirement of noggings. However, reference must also be made to the relevant technical performance tables (1 - 6b) on the previous pages to establish the need for noggings in fire-rated situations.

Table 7 – Provision of timber noggings within timber floors

Board thickness	Maximum joist centres	
	with noggings mm	without noggings mm
6mm Glasroc F MULTIBOARD	450	400
10mm Glasroc F MULTIBOARD	600	450
12.5mm Gyproc plasterboard / Glasroc F MULTIBOARD	600	450
15mm & 19mm Gyproc plasterboard	600	600

**(NB)** Perimeter noggings are required if the floor is required to provide fire resistance.



### Important information

Timber noggings are always required around the ceiling perimeter, except when using 15mm Gyproc WallBoard and 19mm Gyproc Plank in non fire-rated situations. In multi-layer plasterboard ceilings, the provision for noggings relates to the outer layer board only (unless otherwise stated).

#### Joist width

Where the joist width is less than the minimum stated in tables 1 - 6b, the system may not meet its specified performance.

Minimum truss dimensions must be achieved per relevant test evidence, however, in addition where minimum fixing tolerances cannot be met, e.g. the inadequate bearing surface afforded by 35mm width trussed rafters, 50mm x 25mm timber battens should be screw-fixed to the side of the joists where ceiling boards abut in order to extend the bearing surface.

► Refer to construction detail 6.

#### Nail popping

Loosening of nails in timber can occur through timber shrinkage, or as a result of fixing boards to misaligned or twisted framing. To reduce the risks, boards should be fixed tight to framing members using Gyproc Drywall Screws penetrating minimum 25mm into the timber. Alternatively, fix Gypframe RB1 Resilient Bar to the underside of timber joists to provide a positive ground for screw-fixing the ceiling linings. In tests where joists warped and twisted under drying shrinkage, Gypframe RB1 Resilient Bar was successful in providing a sound base for plasterboard fixing, resulting in no fixing defects. Gypframe RB1 Resilient Bar also contributes to the sound insulation of a timber joist floor.

#### Fixing to super-dried timber and engineered timber 'T' beams

Test results show that Gyproc Drywall Screws are the preferred solution for fixing to standard softwood, super-dried timber (approximately 12% moisture content) and engineered timber 'T' beams.

#### Existing lath and plaster ceilings

Acoustically, lath and plaster provides similar performance to 2 layers of 15mm Gyproc SoundBloc or inner layer 19mm Gyproc Plank and outer layer 12.5mm Gyproc SoundBloc. In the event of fire it is critical that the lath and plaster remain in place. Due to their variable nature, it is not possible to provide a fire resistance.

In order to ensure the required fire resistance of a floor is achieved, it is recommended to under-draw the lath and plaster with chicken wire (fixed in accordance with manufacturer recommendations). A cavity should then be formed with minimum 38 x 38mm timber battens or Gyplyner.

#### Services

The installation of electrical services should be carried out in accordance with *BS 7671*. Electrical and other small service runs can be routed within the floor cavity. Concealed cables may need earthed metallic covering, or to be enclosed in earthed conduit, trunking, or ducting to satisfy *BS 7671*.

#### Fixtures

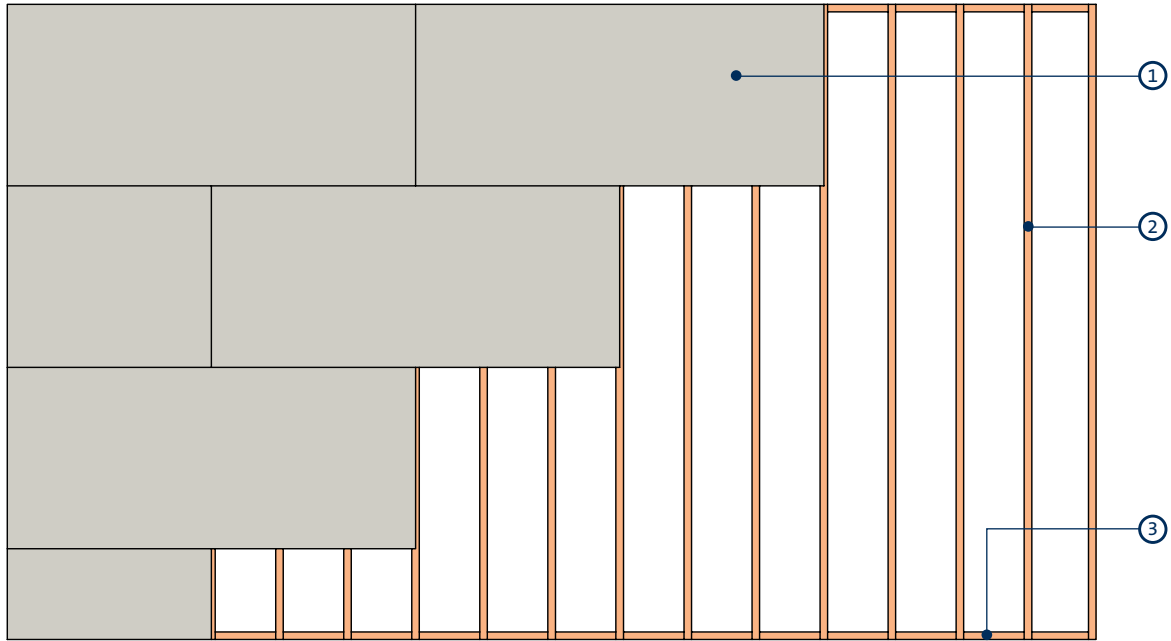
Fixtures should be made into joists, or to supplementary timber. Care must be taken not to bridge Gypframe RB1 Resilient Bar.

#### Board finish

► Refer to C08. S01. P483 – Finishes.

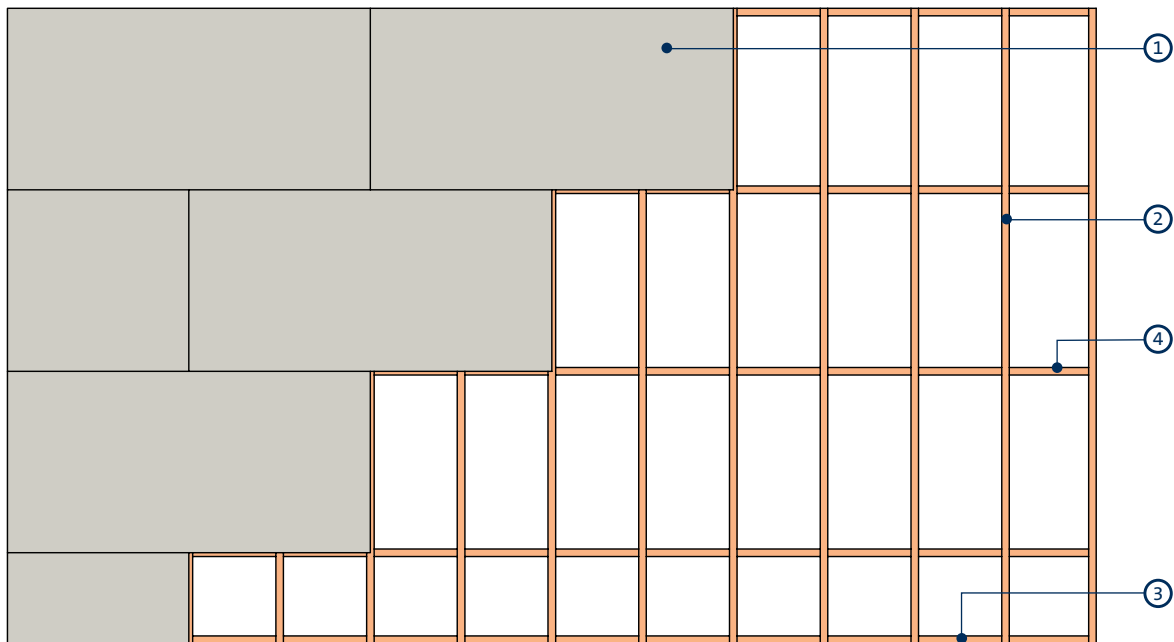
# Loadbearing timber joist floors construction details

1



Reflected ceiling plan - single layer. 12.5mm plasterboard with joists at maximum 450mm centres (or 15mm plasterboard with joists at maximum 600mm centres)

2



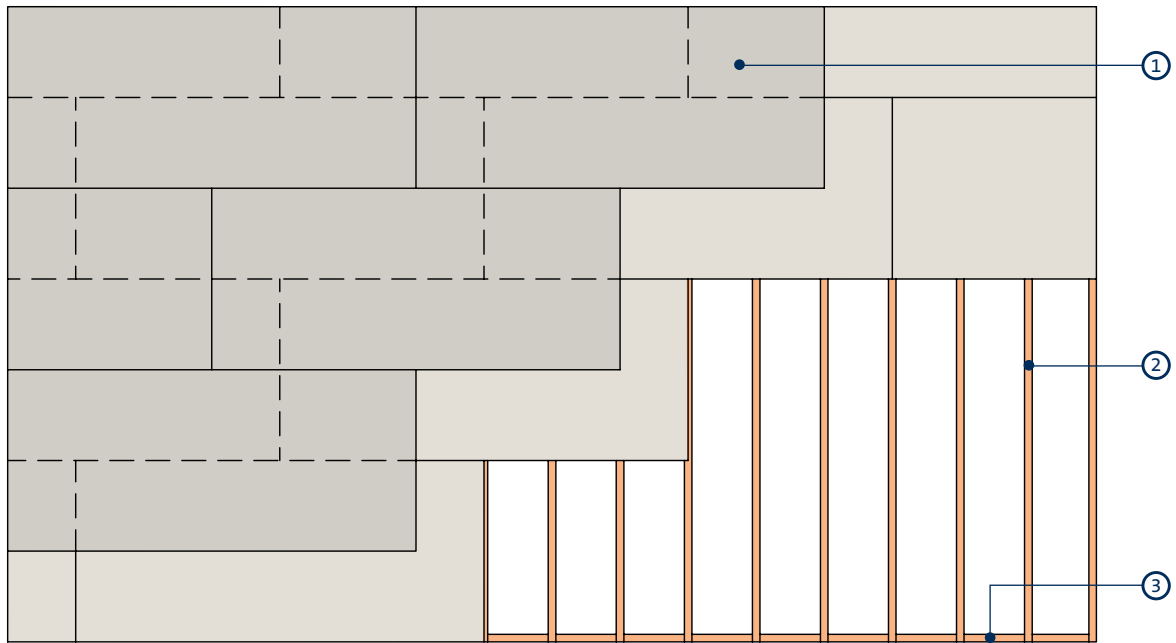
Reflected ceiling plan single layer - 12.5mm plasterboard with Gypframe RB1 Resilient Bars at maximum 450mm centres

- 1 Gyproc plasterboard
- 2 Timber joist
- 3 Timber noggings to provide support at the perimeter
- 4 Timber noggings to provide support board edges

**NB** Refer to C06. S05. P413 - table 7 for the provision of timber noggings.

## Loadbearing timber joist floors construction details (continued)

3

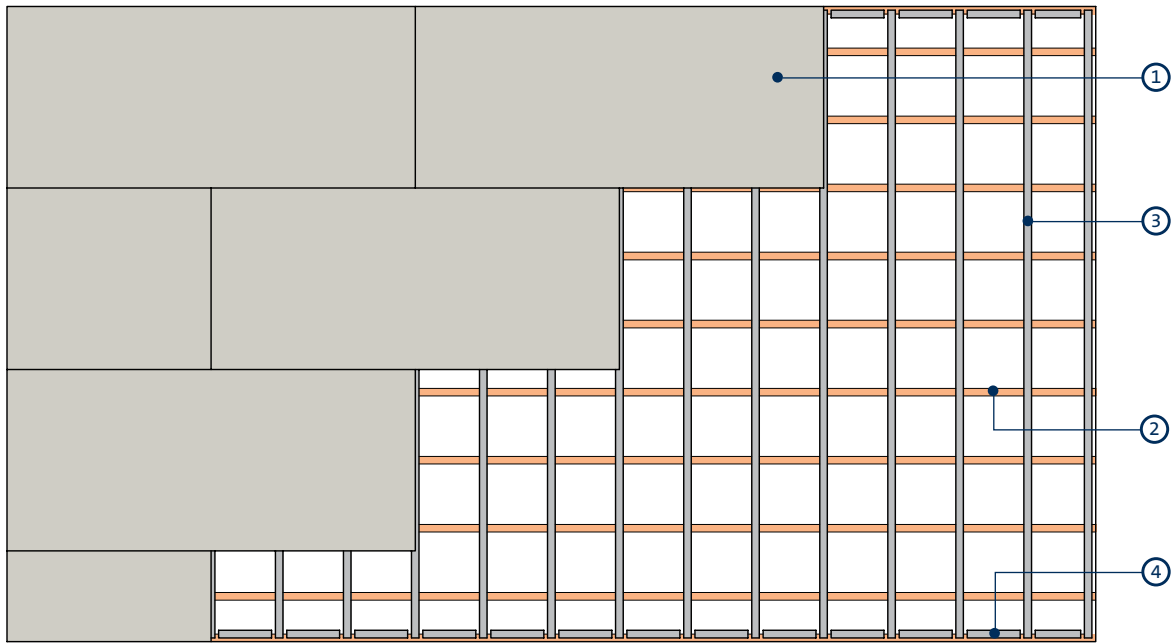


Reflected ceiling plan double layer - 12.5mm plasterboard with joists at maximum 450mm centres  
(noggings may be required to support long edges of board of outer layer if fire-rated)

- 1 Gyproc plasterboard
- 2 Timber joist
- 3 Noggings to provide support at the perimeter

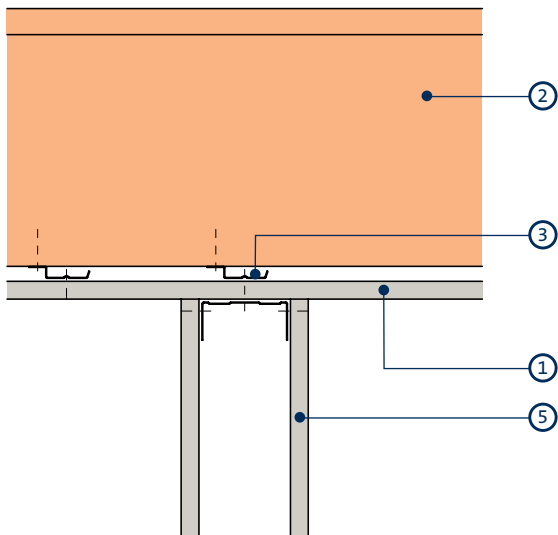
**NB** Refer to C06.S05.P413 - table 7 for the provision of timber noggings.

4



Reflected ceiling plan single layer - 12.5mm plasterboard with Gyframe RB1 Bars at maximum 450mm centres

5



Partition head fixing to ceiling with Gyframe RB1 Resilient Bar

- 1 Gyproc plasterboard
- 2 Timber joist
- 3 Gyframe RB1 Resilient Bar

- 4 Gyframe RB1 Resilient Bar noggings at perimeter
- 5 GypWall

# Loadbearing timber joist floors components

## Gypframe metal components



### Gypframe RB1 Resilient Bar

Acoustically engineered channel to separate board fixing from timber joist and to overcome nail popping. Fixed to underside of joists.

## Board products



### Gyproc WallBoard<sup>1</sup>

Standard gypsum plasterboard.



### Gyproc FireLine<sup>1,2</sup>

Gypsum plasterboard with fire resistant additives.



### Gyproc Moisture Resistant

Gypsum plasterboard with moisture resistant additives in the core and special green lining paper for easy recognition. To receive tape and joint finish.



### Glasroc F MULTIBOARD

Non-combustible glass-reinforced gypsum board.



### Gyproc Plank

Standard gypsum plasterboard located as an inner layer.



### Glasroc F FIRECASE

Non-combustible glass-reinforced gypsum board.



### Gyproc SoundBloc<sup>1,2</sup>

Gypsum plasterboard with a high density core for enhanced sound insulation performance.

<sup>1</sup> Also available in DUPLEX grades where vapour control is required.

<sup>2</sup> Also available in Moisture Resistant (MR) version. MR boards are specified in intermittent wet use areas

## Fixing products



### Gyproc Drywall Screws

Corrosion resistant self-tapping steel screws for fixing board-to-timber and board-to-metal framing less than 0.8mm thick.



### Gyproc Collated Drywall Screws

Corrosion resistant self-tapping steel screws for fixing board-to-timber and board-to-metal framing less than 0.8mm thick.



### Glasroc F FIRECASE Screws

Corrosion resistant self-tapping steel screws with unique head design that countersinks itself for fixing Glasroc F firecase boards to timber joists at 150mm centres.

## Loadbearing timber joist floors components (continued)

### Plasterboard accessories



#### Gyproc Jointing Materials

Jointing compounds, ready mixes and adhesives for reinforcement and finishing of board joints.



#### Gyproc Sealant

Used to seal air paths for optimum sound insulation.



#### Gyproc Drywall Primer

Used to prepare for painting. Tub contents 10 litre.



#### Gyproc Paper Joint Tape

A paper tape designed for reinforcement of flat joints or internal angles.

### Plaster products



#### Gyproc Skimcoat

To provide a plaster skim finish on most common backgrounds including undercoat plasters and plasterboard. Can provide enhanced acoustic performance.



#### Gyproc Carlite Finish

To provide a plaster skim finish on most common backgrounds including undercoat plasters and plasterboard. Can provide enhanced acoustic performance.



#### Gyproc Carlite Ultra Finish

Offers all the benefits of Gyproc Skimcoat and Gyproc Carlite Finish with a reduced set time of 90-120mins, making it ideal for smaller jobs.



#### Plaster accessories

Designed for the reinforcement and finishing of board joints before plaster skimming.



#### Gyproc Bonding Coat

A lightweight undercoat plaster for use over smooth or medium suction backgrounds. Applied at a depth of 10mm on walls or 8mm on ceilings. Bonding Coat Short Set also available with a reduced set time of 90-120 mins making it ideal for smaller jobs.

### Insulation products



#### Isover Spacesaver Ready-Cut

Glass mineral wool for enhanced acoustic and thermal performance.



#### Isover Acoustic Roll

Glass mineral wool for enhanced thermal performance.



#### Isover Sound Deadening Floor Slab

Glass mineral wool for enhanced acoustic performance.

#### Stone Mineral Wool

(24kg/m<sup>3</sup> and 45kg/m<sup>3</sup>, by others)

# Loadbearing timber joist floors installation overview

This is intended to be a basic description of how the system is built.



Gyproc plasterboards can be fixed directly to the underside of timber joists. Timber noggings are fitted, where required, between joists at room perimeters to support board edges. Noggings may also be required to support board edges in the field of the boards. Plasterboards are fixed to timber supports using Gyproc Drywall Screws.



Alternatively, Gypframe RB1 Resilient Bars are fixed through the single fixing flange to the underside of timber joists (at 90° to them) using Gyproc Drywall Screws. The first and last rows of Gypframe RB1 Resilient Bars are located at all wall perimeters.

Where bars are not long enough to span the ceiling, ends are butted together directly under a joist and screw-fixed through the flange of both ends.



Gyproc plasterboards are fixed to the underside of Gypframe RB1 Resilient Bars with Gyproc Drywall Screws.



When fixing boards, care must be taken to ensure that the plasterboard fixing screws do not make contact with the joists.



## Additional information

For full installation details, refer to the **Gyproc Installation Guide**, available to download from [gyproc.ie](http://gyproc.ie)



# Cavity fire barriers

Fire separation within concealed spaces



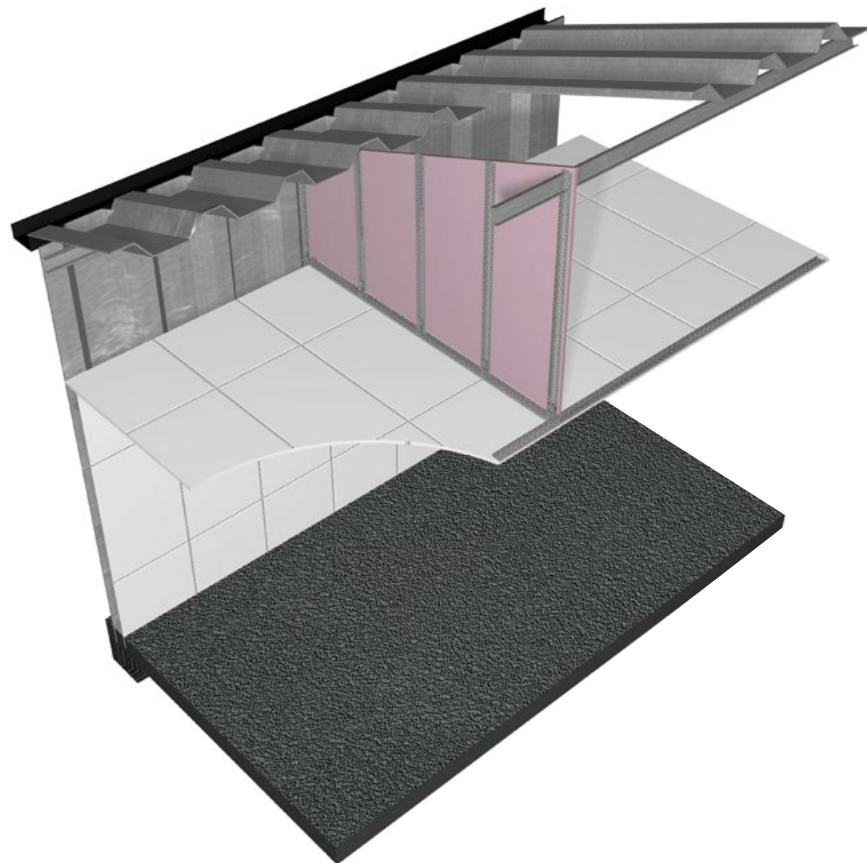
## Cavity fire barriers

Regulatory requirements demand that cavities and concealed spaces, in the structure or fabric of a building, are sub-divided or sealed by means of cavity barriers or fire-stopping to restrict the hidden spread of smoke and flames. This is of prime importance since many buildings are honeycombed with concealed cavities and voids within the roofs, floors, and walls.



### Key benefits

- Cavity barrier performance options to match partition performances up to 60 minutes fire resistance
- Fire separation is maintained throughout the life of the building due to the board lining being mechanically fixed
- High level of component commonality with **GypWall** partition systems



# Cavity fire barriers performance

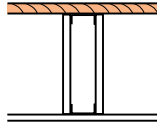
## Cavity fire barriers typical applications

For details of when to specify fire resistance using EN  
 ▶ Refer to C02. S01. P18



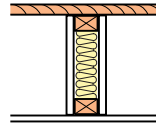
Table 1a – Solutions to satisfy the requirements of BS EN 1364-1: 1999

①



Gypframe 48 S 50 'C' Stud framework with studs at 600mm centres. Linings each side, as in table, fixed using Gyproc Drywall Screws at 300mm centres. Fire-stopping material, e.g. stone mineral wool to the perimeter as necessary.<sup>1</sup>

②



63mm x 38mm timber stud framework with studs at 600mm centres. Linings each side, as in table, fixed using Gyproc Drywall Screws at 300mm centres. 25mm Isover Acoustic Roll in the cavity. Fire-stopping material, e.g. stone mineral wool to the perimeter as necessary.<sup>1</sup>

Detail	Board type	Lining thickness mm	Fire resistance		System reference
			Integrity minutes	Insulation minutes	
①	Gyproc WallBoard	1 x 15	30	30	A206002
②	Gyproc WallBoard	1 x 15	30	30	A026010
①	Glasroc F MULTIBOARD	1 x 12.5	60	60	G106010

<sup>1</sup> Refer to construction details 1 and 2.

**NB** The fire resistance and sound insulation performances are for imperforate partitions, with all joints taped and filled, or skimmed according to Gyproc's recommendations. The quoted performances are achieved only if Gyproc and Isover components are used throughout, and the Company's fixing recommendations are strictly observed. Any variation in the specifications should be checked with Gyproc.

# Cavity fire barriers design

## Planning – key factors

The maximum distance between barriers must be appropriate to the location of each cavity. Also, due consideration must be given to the class of surface exposed within the cavity.

It is also important that smoke and flames are restricted from passing from any cavity in a building element directly into a room or another cavity. Therefore, a cavity must be closed by a cavity barrier at every junction with another cavity. Any cavity contained within an element is also required to be closed by a cavity barrier around the perimeter of any opening through the element. The closure of cavities may already be provided by the construction itself, e.g. where a Gyproc partition system prevents the continuation of cavities at a 'T' junction.

Smoke and flames must also be restricted from by-passing any building elements that are required to have fire resistance. Any cavity crossing the edges or ends of a fire resistant element should have a cavity barrier provided in the same plane as the element, refer to construction details 3 and 4. There are certain exceptions to this requirement, such as cavities in floors and roofs where the ceilings provide a minimum of 30 minutes fire resistance in addition to satisfying other stipulated requirements.

Cavity barriers must maintain their performance during the life of a building, taking account of any possible building movement due to subsidence, shrinkage, or thermal change. In addition, the possible failure of its fixings or adjacent construction in the event of a fire, and the collapse in a fire of any permitted services penetrating the cavity barrier, should be considered.



## Important information

Fixings through the cavity barrier framework into the structural soffit must be capable of supporting the weight of the entire cavity barrier construction.

Gyproc ceiling solutions are not intended to provide any support to the cavity barrier.

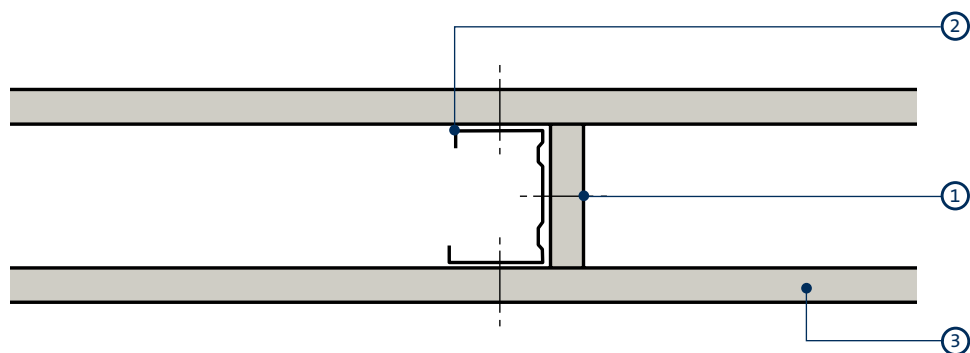
## Fire stopping

A cavity barrier must be tightly fitted to a rigid construction, or, if it abuts against slates, tiles, corrugated sheeting, or other construction to which it cannot be so fitted, then it must be suitably fire-stopped at the junction. Refer to construction details 1 - 2, which show fire-stopping solutions using stone mineral wool.

Any services running through a fire cavity barrier should be fire-stopped using suitable materials, shown by test to maintain the fire resistance within that construction.

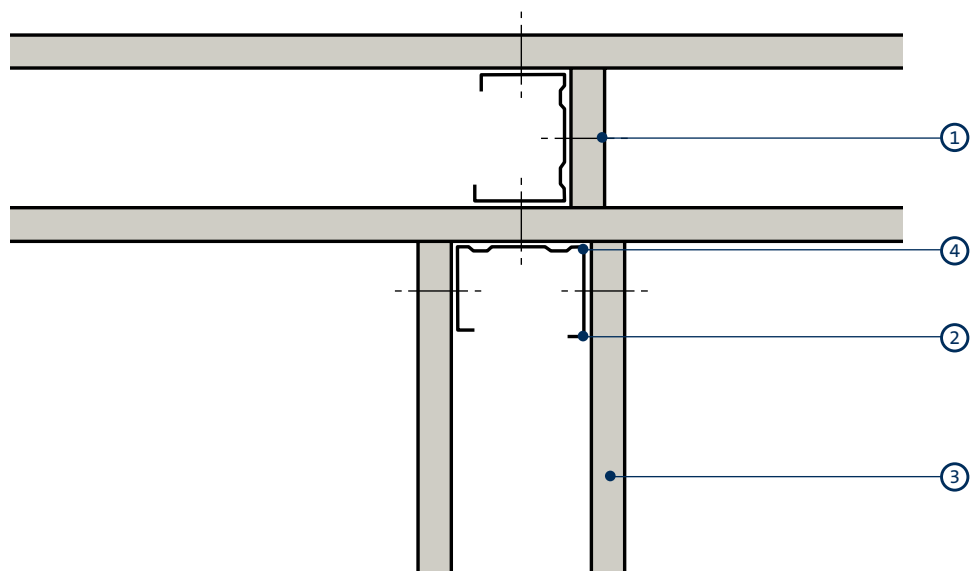
## Cavity fire barriers construction details

1



Sub-division or partition cavity

2

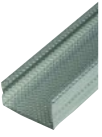


Cavity barrier at 'T' junction of partitions

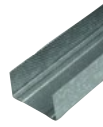
- 1 Gyproc plasterboard or Glasroc F specialist board forming cavity fire barrier
- 2 Gypframe 'C' Stud
- 3 Gyproc plasterboard
- 4 Gyproc Sealant

# Cavity fire barriers system components

## Gypframe metal components



**Gypframe 'C' Studs (48 S 50, 60 S 50, 70 S 50, 70 S 60, 92 S 50, 92 S 60, 92 S 10, 146 S 50)**  
Vertical stud designed to receive fixing of board.



**Gypframe Folded Edge Standard Floor & Ceiling Channels (50 FEC 50, 62 FEC 50, 72 FEC 50, 94 FEC 50, 148 FEC 50)**  
Standard floor and ceiling channels for retaining Gypframe studs at floor and ceiling junctions.



**Gypframe FEA1 Steel Angle**  
Steel angle providing framing stability and board support.

**Timber Framing (by others)**  
To suit.

## Board products



**Gyproc WallBoard**  
Standard gypsum plasterboard.



**Gyproc FireLine<sup>1</sup>**  
Gypsum plasterboard with fire resistant additives.



**Gyproc Moisture Resistant**  
Gypsum plasterboard with moisture resistant additives in the core and special green lining paper for easy recognition.



**Glasroc F MULTIBOARD**  
Non-combustible glass-reinforced gypsum board.

<sup>1</sup> Also available in Moisture Resistant (MR) version. MR boards are specified in intermittent wet use areas.

## Fixing products



**Gyproc Drywall Screws**  
Corrosion resistant self-tapping steel screws for fixing board-to-timber and board-to-metal framing less than 0.8mm thick.



**Gyproc Jack-Point Screws**  
Corrosion resistant self-tapping steel screws for fixing board to metal framing 0.8mm thick and greater ('I' stud 0.6mm thick and greater).



**Gyproc Collated Drywall Screws**  
Corrosion resistant self-tapping steel screws for fixing board-to-timber and board-to-metal framing less than 0.8mm thick.



**Gyproc Wafer Head Drywall Screws**  
Corrosion resistant self-tapping steel screws for fixing metal to metal framing less than 0.8mm thick.



**Gyproc Wafer Head Jack-Point Screws**  
Corrosion resistant self-tapping steel screws for fixing board to metal framing 0.8mm thick and greater.

## Cavity fire barriers system components (continued)

### Insulation products

---



#### **Isover Acoustic Roll**

Glass mineral wool for enhanced acoustic performance.

---

#### **Stone Mineral Wool** (by others)

For fire stopping.

---

## Cavity fire barriers installation overview

The procedure for fixing timber or metal framing to the ceiling / structure, and for fixing Gyproc and specialist boards to form the cavity barrier, is in line with Gyproc's normal drylining recommendations.

▶ Refer to **GypWall** metal stud partitions, or timber stud partitions and separating / compartment walls in the current **Gyproc Installation Guide**, available to download from [gyproc.ie](http://gyproc.ie)



### **Additional information**

---

For full installation details, refer to the **Gyproc Installation Guide**, available to download from [gyproc.ie](http://gyproc.ie)

# C07

Linings

## Linings




This section contains our wall lining systems, covering all applications, from a basic wallboard lining through to high performance linings designed to meet thermal and sound insulation, fire protection, or impact resistance requirements



# Linings

Gyproc systems provide high quality internal linings. They cater for a variety of wall constructions, including metal frame and traditional masonry. Linings can be fully or partially independent of the structure, or can simply be bonded or plastered directly to a wall surface. These products are used in all types of buildings and are equally suited to both new-build and refurbishment work.

Each system section takes you through the process of selecting an appropriate lining to achieve a high performing, quality finish:

System cavity width (mm)	Performance			Method of fixing to wall	System	Page
	 fire	 Acoustic	 Thermal			
-	✓	-	-	Direct <sup>1</sup>	Plaster systems	C07. S02. P459
10 - 25	-	-	-	Gyproc Plasterboard Compound dabs	DriLyner	C07. S03. P469
25 - 125	-	✓	✓	Gypframe GL2 or GL9 Brackets mechanically fixed	GypLyner	C07. S04. P485
60 minimum	✓	✓	✓	Independent of wall	GypLyner iwL	C07. S05. P493

<sup>1</sup> Walls and ceilings.

<sup>2</sup> DriLyner RF system is intended for upgrade purposes.

<sup>3</sup> Performances not included within this section. Contact the Gyproc Technical Department for more information.

## Enhancing the built environment

Gyproc offers a range of systems to deliver rooms and buildings that offer superior levels of living comfort and sustainability.

### Thermal improvement

Gyproc framed lining systems may incorporate Isover mineral wool insulation which can enhance thermal performance and so reduce CO2 emissions and improve occupier comfort.

### Acoustic improvement

Gyproc has a range of wall lining systems that offer a number of acoustic performances. Improvements in the acoustic environment of a building can lead to a number of occupant benefits, including enhanced student learning, improved patient recovery, optimised employee productivity and harmonious family living.

## Good practice specification guidance

It is well recognised in the construction industry that there is an issue with buildings not performing as intended when it comes to energy efficiency, often referred to as the 'Performance Gap'.

In order to minimise this risk there are two key areas of system design and installation to which particular attention should be paid; airtightness and thermal bridging.

To maximise the performance achieved on site, consider the following good practice specification guidance:

- In order to reduce heat loss via convection currents, it is important to seal the perimeter of the insulating element. To achieve best performance, a continuous fillet / ribbon of Gyproc Plasterboard Compound or Gyproc Sealant should be applied to the wall perimeter and around all services and openings as board fixing proceeds, as per individual system design guidance
- Air leakage through blockwork can be significant, particularly through incomplete mortar joints. Air passing through the wall will take heat energy with it, reducing the thermal efficiency of the wall. A continuous 6mm coat of Gyproc Airtite Quiet, applied to the face of the masonry prior to the installation of mechanically fixed or independent lining system, e.g. GyLyner or GyLyner IWL systems, will seal hidden air paths often found in mortar joints between blocks or bricks. For improved acoustic performance, Gyproc Airtite Quiet should not be trowelled smooth
- Walls must be weathertight and free from dampness before any Drilyner or plaster system can be installed
- It is important to achieve as consistent a level of insulation performance as possible across a building element. Areas with less insulation, known as cold bridges, will be prone to attracting condensation and, as a result could promote mould growth. Consideration should be given to minimising the occurrence of cold bridges, for example by applying insulation with appropriate vapour control to lintels and window reveals





# Plaster systems

High quality lining solutions providing the perfect finish for your walls



## Plaster systems

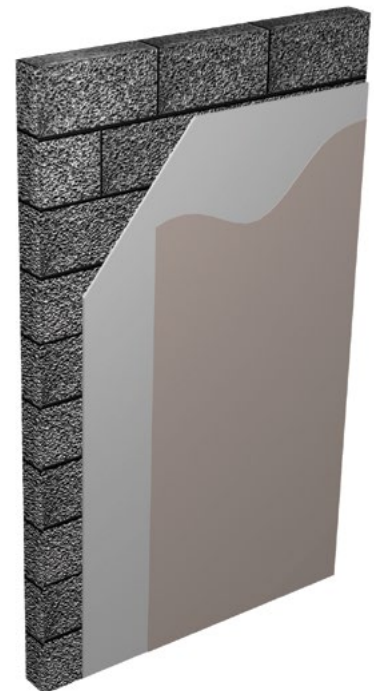
Gyproc plasters offer a full range of specific and multi-purpose solutions for a wide range of internal plastering needs and backgrounds; including concrete, brick, blockwork, expanded metal lath and plasterboard. They are designed to suit either hand or machine application.



Backed up by a range of compatible, high quality accessories, Gyproc plasters produce a high quality surface that's tough and durable.

### Key benefits

- Gyproc plasters provide a long term high quality appearance. They range from extra durable plasters that resist scuffs and knocks, to plasters specifically designed for different types of background
- Gyproc plaster is ideal for use where thermal mass is an integral part of the design of the building. Plaster provides the desired decorative finish whilst also enabling efficient heat transfer between the air and the fabric of the building
- Plastering contributes to the overall airtightness of masonry walls
- Gyproc two-coat plasters are highly durable and resistant to damage, reducing whole life costs and potentially extending maintenance cycles

















### You may also be interested in...

Plaster skimming to plasterboards is a popular method of providing a smooth, seamless surface ready to receive decorative treatment. Skim plastering gives many of the advantages of a traditional solid plaster finish combined with quick turnaround on site. Surface preparation simply involves joint reinforcement and, if tapered edge board is used, flushing-out the tapers. The plaster is applied to the wall or ceiling surface to a nominal 2mm thickness. Refer to page C08. S02. P511 for further information.

# Plaster selection

Table 1a — Gyproc plaster selector













-  Use **Gyproc GypPrime** for suction control where you see this symbol
-  Use **ThistleBond-it** as a bonding agent where you see this symbol

Background Surface	Undercoat Plasters			One Coat Plaster
				
Low density thermal blocks	 To control suction where appropriate			
Common concrete blocks				
Medium density concrete blocks				
Dense concrete blocks	Not on smooth low suction blocks	 On smooth low suction blocks	 On smooth low suction blocks	Not on smooth low suction blocks
Dry mature sand/cement Suitably scratched to provide key				
Dry gypsum based undercoats Suitably scratched to provide key				
Set but not fully dry gypsum based undercoats Suitably scratched to provide key				
Standard Gyproc Plasterboards and Glasroc F Boards (not 6mm)				
Moisture Resistant (MR) Gyproc Plasterboards and Glasroc F MULTIBOARD				
Rear (grey paper side) face of Gyproc Plasterboards e.g. WallBoard, etc.		 On MR boards	 On MR boards	
Flat, smooth in-situ and pre-cast concrete		 On MR boards	 On MR boards	
Thickness applied - Walls	11mm	10mm	10mm	10-13mm
Thickness applied - Ceilings	N/A	8mm	8mm	N/A
Coverage per bag	3.0m <sup>2</sup> @ 11mm	3.0m <sup>2</sup> @ 10mm 3.7m <sup>2</sup> @ 8mm	3.0m <sup>2</sup> @ 10mm 3.7m <sup>2</sup> @ 8mm	3.0m <sup>2</sup> @ 10mm
Approx water requirement (per bag) <sup>1</sup>	15L	16L	16L	18L

1 Adjust water ratio to achieve preferred mixed consistency

## Plaster selection (continued)

Table 1b — Gyproc plaster selector

Finishing Plasters			Specialist Plasters	
				
Gyproc Skimcoat	Gyproc Carlite Finish	Gyproc Carlite Ultra Finish	Gyproc Airtite Quiet	Gyproc Magnetic Plaster
Dampen walls first to achieve appropriate suction	Dampen walls first to achieve appropriate suction	Dampen walls first to achieve appropriate suction		
Dampen walls first to achieve appropriate suction	Dampen walls first to achieve appropriate suction	Dampen walls first to achieve appropriate suction		Dampen walls first to achieve appropriate suction
				
				
2mm	2mm	2mm	6mm	3-6mm
2mm	2mm	2mm	-	-
9.4m <sup>2</sup> (Undercoat) 11.25m <sup>2</sup> (Plasterboard)	9.4m <sup>2</sup> (Undercoat) 11.25m <sup>2</sup> (Plasterboard)	9.4m <sup>2</sup> (Undercoat) 11.25m <sup>2</sup> (Plasterboard)	4.5m <sup>2</sup> @ 6mm	5.1m <sup>2</sup> @ 3mm
13L	13L	13L	16L	8.5L

# Plaster systems design

## Building design

In general, normal thicknesses using undercoat / finish plaster systems are 11mm to walls or up to 8mm to ceilings, plus 2mm of finish plaster.

One coat products are applied to the same total thickness, i.e. 13mm to walls or up to 10mm to ceilings.

When using Thistle Bond-it or plastering ceilings, do not exceed the thicknesses given. In cases involving both the use of a bonding agent and a sloping or horizontal background, e.g. the underside of concrete stair or floor units, it is strongly advised to reduce thickness further to minimise stress placed on the bonding agent. Greater thickness requires the use of a support for the suitable plaster, e.g. bonding coat onto metal lathing.

► Refer to table 1a.

For plaster systems used on walls that do not use a bonding agent, thicknesses up to a maximum of 25mm, may be built up in a series of fully keyed coats of nominally 8mm using the same undercoat product throughout. Total thickness over 25mm normally requires the use of expanded metal lathing for Gyproc Bonding Coat. If necessary this can be spaced away from the background, e.g. by fixing to timber battens.

## Fire resistance

In refurbishment projects, where there is a deficit in concrete cover over the reinforcement, Gyproc plasters can be used to restore the required fire resistance specification. This is particularly relevant if an increased level of fire protection due to change of use is required.

Using Gyproc plaster can offer fire protection and enhanced cosmetic appearance. The tables in BRE Report 128 can be used to determine the level of performance achieved by the existing construction and advise on the required thickness of gypsum plaster, e.g. Gyproc Bonding Coat finished with Gyproc Finish Plasters to achieve the required fire performance. Expanded metal lath should be used to ensure adhesion to the concrete.



## Important information

BRE report BR128 "Guidelines for the construction of fire-resisting structural elements" is recognised in regulatory requirements.

## Reaction to fire

Gypsum plaster is non-combustible and achieves EN Euroclass A1. Gypsum plaster also achieves Class 0 spread of flame as defined by Building Regulations. It contains water, chemically combined in its crystalline structure, that has to be driven off before the cold face temperature can rise above 100°C.

## Background preparation

All surfaces should be reasonably dry and protected from the weather. Backgrounds need to be suitable with regards to:

- It's strength – can it take the weight of the plaster
- Suction – how quickly will it pull the moisture out of the plaster as it sets
- Bonding properties – does it have a texture for a key
- Shrinkage – will it continue to shrink underneath a layer of plaster
- Thermal movement characteristic – will it expand or contract causing the plaster to crack
- Water and soluble salt content – are the levels likely to cause problems to the key or finish

If there is any doubt about the suitability of a background for direct plastering, a trial panel should be plastered and tested for adhesion once dry. If adhesion is inadequate, the appropriate preparation and bonding agent must be applied to the background prior to plastering.



## Important information

- Gyproc plasters should only be applied to backgrounds where the minimum temperature will remain at 5°C or above until dry
- Gyproc plasters should not be specified for use where temperatures exceed 49°C

## Preparation

Backgrounds such as smooth concrete or concrete made from limestone and certain lightweight aggregates, will require preparation and pre-treatment with Thistle Bond-it bonding agent prior to plastering. The surface should be thoroughly cleaned and allowed to dry before pre-treatment.

Gyproc GypPrime bonding agent should be used to pre-treat surfaces where suction is extremely high. With some very porous surfaces, wetting alone may be insufficient as the water is almost immediately absorbed.

If there is any doubt about the suitability of a background for direct plastering, a trial panel should be plastered and tested for adhesion once dry. If adhesion is inadequate, the appropriate bonding agent must be applied to the background prior to plastering.

The surface must be clean, dry and suitable to receive gypsum plaster.

Very high or low suction substrates should be pre-treated. The use of Thistle Bond-it is recommended for smooth and / or low suction backgrounds. Thistle Bond-it bonding agent is specially formulated for use on smooth backgrounds. It has many advantages over PVA and is the only bonding agent recommended for use with Gyproc gypsum plasters (excluding Gyproc Hard Coat). Benefits include:

- Contains fine aggregates for better mechanical adhesion

## Plaster systems design (continued)

- Applied in one coat only
- Plaster is applied when Thistle Bond-it is dry, allowing flexible timing of application
- Plaster can be applied at normal thickness, i.e. up to 13mm
- Maximum 8mm on soffits
- No dilution required, ensuring consistent product application
- Green coloured for ease of identification in application

The high suction of certain backgrounds can be suitably adjusted by sprinkling with water but some very porous surfaces, wetting alone may be insufficient as the water is almost immediately absorbed.

Gyproc GypPrime bonding agent is specially formulated for the pre-treatment of very high suction backgrounds. It is the only suction control primer recommended for this use with Gyproc plasters. It can be diluted as required, giving total flexibility, for different levels of suction control, and is yellow coloured for ease of identification.

Thistle Bond-it and Gyproc GypPrime should be applied strictly according to the user instructions. Care should be taken not to exceed the recommended plaster thickness otherwise bond failure may occur. Where a greater thickness of plasterwork is required, due to an uneven background for example, expanded metal lathing and Gyproc Bonding Coat should be specified.

### Brickwork / blockwork

On high suction brickwork / blockwork the use of Gyproc Hard Coat is recommended. Aerated concrete blocks can give rise to high suction. Suction can be controlled with water or, if severe, pre-treated with Gyproc GypPrime.

Low suction backgrounds provide minimal absorption. The joints should be raked thoroughly to give an adequate mechanical key. Smooth backgrounds should be pre-treated with Thistle Bond-it. Dense aggregate concrete blocks typically do not require wetting prior to plastering, but the plaster should be applied with very firm pressure to ensure intimate contact with the background.

### Concrete

The surface must be clean, dry and suitable to receive gypsum plaster. Any mould, oil or other release agents present must be thoroughly removed from the surface.

Normal ballast concrete should be given sufficient time to mature before applying plaster. The plaster should not be applied onto a green background or when any free water is visible. Mature concrete will require wetting to displace the air before plastering. Clean water should be applied 5 - 10 minutes before plaster application. In-situ or precast concrete that is smooth will require pre-treatment with Thistle Bond-it.

No-fines concrete does not typically require wetting prior to plastering. Pre-cast concrete units should be plastered with Gyproc Bonding Coat.

With composite ceilings, the concrete beams should be pre-treated with Thistle Bond-It. If required, the suction of the infill panels can also be controlled.

To reduce the risk of cracking, the floating coat should be applied with sufficient pressure to fill all gaps between the units.

### Combination backgrounds

The right product for each part of the background should be used, with joints formed using back-to-back Gyproc stop beads, but this can be impractical, e.g. narrow concrete columns or lintels within block walls. These should be bridged using metal lathing and the plaster isolated from the concrete using building paper. Refer to Annex B3 of *BS EN 13914-2*.

### Control joints

It is common for movement joints to be included in masonry construction. Where these occur, back to back Gyproc plaster Stop Beads should be used.

### Expanded metal lath / beads

Gyproc plasters should only be applied to galvanised steel or epoxy coated stainless steel. Before plastering, all cut edges, damaged metal lath, staples, nail heads and ends of tying wire should be bent inwards and adequately protected by galvanising, painting or by applying a thick coat of lacquer.

Normal application to expanded metal lath employs a pricking-up coat, which should be forced through the metal lath to provide a good key to the background. The surface of the pricking-up coat must be wire-scratched to provide a good key for a floating coat of the same undercoat plaster. The pricking-up coat must be allowed to set but not too dry before the floating coat is applied.

Floating coats should be applied at a thickness of 8mm, up to a total plaster thickness of 25mm, and wire-scratched between each coat. The final floating coat should be ruled to an even surface and lightly scratched to form a key for Gyproc Finish Plasters.

Machine applied undercoat requires the use of spray lath.

### Sand / cement undercoats

Cement based undercoats shrink on drying, usually with some cracking, which can appear several days or even weeks after application. If a Gyproc Finish Plaster is applied before the shrinkage is complete there is an increased risk of delamination or cracking of the finish, particularly if the undercoat was not thoroughly keyed.

The key provided to cement-based undercoats needs to be much deeper and the drying time allowance much longer than for gypsum-based undercoats. Retarded ready-mixed sand / cement mortars may have delayed shrinkage, and may contain additives that interfere with the setting or strength of Gyproc Finish Plasters.

## Plaster systems design (continued)

### Mixing

Gyproc plasters should be mixed by adding to clean water using clean mixing equipment. Contamination from previous mixes can adversely affect the setting time and strength. Fresh contamination has more effect than old, so equipment should be washed immediately after mixing.

Gyproc plasters are suitable for mixing by hand or mechanical whisk of a slow speed, high torque type. While mechanical mixing speeds the process up, there is no need to continue mixing after dispersing lumps and achieving the right consistency. Over-mixing wastes time and energy, can affect setting times, lead to deterioration in workability and create difficulty in achieving a flat finish.

### Projection plastering

Gyproc Hard Coat is suitable for machine application. Plaster should be sprayed on to the background in the form of a ribbon. The consistency should allow the ribbons to run together. When a substantial area has been covered, the plaster is worked and ruled as in hand plastering. The total thickness should not normally exceed 25mm, subject to background suitability.

### Decoration

Gyproc plasters can be decorated with most paint finishes and most wall coverings. Follow manufacturers' recommendations. Impermeable finishes including tiles, should not be applied until the background and plaster are dry. A permeable paint can be used in the interim. Take care with Gyproc Hard Coat as it dries from the surface, appearing surface dry before fully dry in its depth. *BS EN 13914 - 2: Design Considerations and Essential Principles for Internal Plastering* states that plastering should be done under similar or better lighting conditions than the final work will be judged in. This is particularly important for glossy finishes and / or low angle natural or artificial lighting.

### Tiling

Tiles up to 20kg/m<sup>2</sup> can be applied to Gyproc Hard Coat once a suitable proprietary tiling primer has been used. If plastering to provide a background for tiles, avoid polishing the surface. Polished plaster surfaces should be roughened and a suitable primer used. Tiles should not be applied directly to Gyproc Finish Plasters.

# Plaster systems components

## Plaster products



### Gyproc Bonding Coat

Undercoat plaster for most smooth or low suction backgrounds.



### Gyproc Bonding Coat Short Set

Offers all the benefits of Gyproc Bonding Coat with a reduced set time of 90 - 120 mins, making it ideal for smaller jobs.



### Gyproc Hard Coat

Undercoat plaster with high impact resistance for most masonry backgrounds.



### Gyproc Airtite Quiet

A specially formulated parge coat to reduce air permeability and to seal background surfaces to enhance sound insulation when drylining.



### Gyproc Skimcoat

To provide a plaster skim finish on most common backgrounds including undercoat plasters and plasterboard. Can provide enhanced acoustic performance.



### Gyproc Carlite Finish

To provide a plaster skim finish on most common backgrounds including undercoat plasters and plasterboard. Can provide enhanced acoustic performance.



### Gyproc Carlite Ultra Finish

Offers all the benefits of Gyproc Skimcoat and Gyproc Carlite Finish with a reduced set time of 90-120mins, making it ideal for smaller jobs.



### Gyproc Magnetic Plaster

To provide a plaster skim finish that provides an attraction to magnets used to finish a wide range of backgrounds, including undercoat plasters and plasterboard.

## Plaster systems components (continued)

### Plaster accessories

---

**ThistleBond-it**

Bonding agent for smooth and/or low suction backgrounds providing an adequate key.

---

**Gyproc GypPrime**

Primer to reduce suction on very dry backgrounds.

---

### Plasterboard accessories

---

**Gyproc Paper Joint Tape**

A paper tape designed for reinforcement of flat joints or internal angles providing superior resistance to cracking.

---

## Plaster systems installation overview

This is intended to be a basic description of how the system is built.



Gyproc plasters should be mixed by adding to clean water and using clean mixing equipment. Contamination from previous mixes must be avoided as this can adversely affect the setting time and strength.



Gyproc plaster Angle Bead or Gyproc plaster Stop Bead is fixed to the background by embedding in the undercoat plaster.

Where Gyproc Bonding Coat undercoat plaster is to be applied to plasterboard, the board joints are reinforced with Gyproc Paper Joint Tape bedded in Gyproc plaster.



Where necessary, Thistle Bond-it may be required to provide a mechanical and chemical key for the appropriate undercoat plaster.



Once the correct Gyproc plaster has been selected to suit the background suction and surface texture, the plaster is applied in maximum 8mm coats. Each coat is allowed to set before applying the next.



The final coat is ruled to an even surface and lightly scratched to form a key for Gyproc Finish Plasters.



Once the Gyproc undercoat plaster has set, Gyproc Finish Plaster is applied with firm pressure, built out to the required thickness in two applications and trowelled to a smooth matt finish. In some circumstances it may be necessary to control the suction with Gyproc GypPrime. Good site practice should be followed, as outlined in *BS EN 13914 - 2 Design considerations and essential principles for internal plastering*.



### Additional information

For full installation details, refer to the **Gyproc Installation Guide**, available to download from [gyproc.ie](http://gyproc.ie)

# DriLyner Wall Linings




Drywall masonry lining systems



# DriLyner Wall Linings

Gyproc **DriLyner** systems provide high quality internal linings. They cater for a variety of masonry wall constructions. Linings are bonded using a wide range of adhesive options depending on substrate type. This range of systems provide solutions for all types of buildings both new-build and refurbishment.

Use the table below to select the most appropriate solution for your project requirements.

System cavity width (mm)	Performance			Method of fixing to wall	System	Page
	 fire	 Acoustic	 Thermal			
10 - 25	-	-	✓	Gyproc Plasterboard Compound	DriLyner	C07. S03. P470
20 - 25	-	-	✓ <sup>1</sup>	Gypframe MF10 Channels fixed using Gyproc Plasterboard Compound dabs	DriLyner MF	C07. S03. P471

<sup>1</sup> Performances not included within this section. Contact the Gyproc Technical Department.

# DriLyner range

## DriLyner

**DriLyner** lining system provides a straightforward solution for fixing Gyproc plasterboards directly to masonry backgrounds using gypsum adhesive dabs.

**DriLyner** is suitable for fixing a wide range of plasterboards to non-plastered masonry substrates.

### Key benefits

- Minimal loss in room space due to a typical 15mm drylining cavity plus the thickness of the Gyproc plasterboard and any finish applied
- Allows minor surface irregularities to be taken out within the drylining cavity formed by the gypsum adhesive dabs
- Services can be incorporated with a reduced level of chasing



## DriLyner range (continued)

### DriLyner MF

**DriLyner MF** lining system provides a solution for fixing Gyproc plasterboard, including Gyproc WallBoard DUPLEX incorporating a vapour control layer directly to masonry backgrounds using gypsum adhesive dabs and Gypframe channels. High levels of energy efficiency can be achieved to upgrade the performance of existing walls.

#### Key benefits

- Services can be incorporated without chasing of the masonry substrate
- Allows minor surface irregularities to be taken out within the drylining cavity formed by the gypsum adhesive
- Minimal thermal bridging due to the use of gypsum adhesive dabs between the Gypframe channel and masonry background
- Provides a thermally responsive environment with a quick heating time as a result of positioning the insulation layer on the warm side of the room



# Drilyner Wall Linings performance

## Fire protection

Plasterboard is designated a 'material of limited combustibility' within Building Regulations TGD Part B (RoI) and Technical Booklet E (NI).

## Sound Insulation

Airtightness is essential for optimum sound insulation. Whilst most junctions will be sealed by standard installation and finishing processes, gaps at the base of the wall and other small air paths can be sealed using Gyproc Sealant.

## Thermal properties

Gyproc linings are relatively lightweight and have a low thermal capacity. In conditions of intermittent heating, they will warm up quickly providing comfortable conditions for the occupants, and will help reduce the risk of surface condensation.

## Condensation and water vapour resistance

Gyproc WallBoard DUPLEX offers significant resistance to water vapour transmission.

It is important, particularly in new buildings, that external walls are properly dried out before a vapour control layer is provided, otherwise moisture may be trapped, impairing the performance of the construction.

*This page left intentionally blank*

## Planning — key factors

The position of services should be pre-determined and their installation planned into the construction stage.

► Refer to C02. S01. P41 – Service installations.

In general, an allowance of the total board thickness plus 10mm for Drilyner should be made from the high point of the background to the face of the lining. This will determine the lining dimension required at door and window reveals and soffits. Ceilings should be installed prior to the application of Drilyner, ensuring that the boards are cut close to the wall.

Interior partitions abutting the inner leaf of the external wall should also be installed prior to installation of Drilyner lining where fire and acoustic performance are a key consideration. This helps to reduce flanking transmission.

## Backgrounds



### Important information

Walls must be free from dampness before Drilyner system can be installed.

Drilyner linings should only be installed to backgrounds that are reasonably dry and protected from the weather.

In the Drilyner system linings can be fixed directly to low, medium, and high suction masonry, as well as pre-cast and in-situ normal ballast aggregate concrete, using Gyproc Plasterboard Compound. Concrete backgrounds must be free of shutter-release agents and will need to be brushed down to remove dust, and slightly dampened with a wet brush prior to applying adhesive dabs. Concrete which is exceptionally dense or smooth, or made with limestone, brick or granite aggregates, should be pre-treated with ThistleBond-It, which should be applied in bands to correspond with the adhesive dab centres and in accordance with Gyproc's application instructions.

Variations in moisture content of the background will lead to differences in its suction characteristics. When these are extreme, either with slow drying conditions, or dry, hot conditions, care must be taken. If wet, allow the backgrounds to dry out. In dry, hot conditions, care should be taken to avoid rapid loss of moisture prior to the set of the adhesive.

When a considerable quantity of moisture may be present in the building, due to the condition of the building fabric or to prolonged damp weather, consideration should be given to the use of dehumidifiers or appropriate heating and ventilation to speed up the drying-out process. Installation of the lining before the building is adequately dry can have an adverse effect on both the building and the lining itself.

When installing Drilyner linings to composite wall structures consisting of concrete columns with infills of brick or block, dabs of adhesive should not be located on the columns but only on the brick or block infill areas. This will reduce the likelihood of cracking of the finished lining as a result of differential movement within the background.

## Adhesive dabs

Dabs should be applied in a regular pattern in accordance with *BS 8212* and *BS 8000: Part 8* to give a minimum area of contact between board and background of 20%.

## Services

The cavity between the linings and the background can be used to incorporate services. This minimises the depth of chasing required in the background. Pipes and conduits should be fixed in position before lining work commences. Gas pipes should be installed in accordance with *BS 6891*, which requires pipes to be fully encased, e.g. using Gyproc Plasterboard Compound. To maintain an airtight construction the perimeter of any penetration through the lining should be sealed as necessary at the time the services are being installed.

The insulating backing of the laminates should not be chased to accommodate services. PVC covered cables must not come into direct contact with polystyrene insulation. Suitable isolation methods such as conduit or capping should be used.

The installation of electrical services should be carried out in accordance with *BS 7671*.

## Cavity barriers

Building Regulations may require the provision of vertical cavity barriers to long runs of lining. A suitable cavity barrier can be formed using a continuous vertical line of dabs running down the centre of a board.

## DriLyner Wall Linings design (continued)

### Thermal performance

Uncontrolled air movement through the drylining cavity can result in excessive heat loss from the building. The benefit of thermal insulation using DriLyner systems are based on a sealed cavity between the lining and the background. This is achieved in practice if the abutting elements and the background are constructed correctly, and junctions are sealed.

When the lining is designed to act as an air barrier to achieve building airtightness, the perimeter of the cavity is to be sealed by applying a continuous fillet / ribbon of Gyproc Plasterboard Compound to the perimeter of the external wall and around any services and openings.

### Sound insulation

Gyproc Airtite Quiet in conjunction with a mechanically fixed lining system, e.g. Gyplyner, is designed to improve the acoustic performance of masonry party walls by minimising acoustic leakage through cracks, unfilled joints or block porosity. When applying Gyproc Airtite Quiet it is recommended that a 6mm coat is applied across the entire surface area of the separating wall to cover all cracks and voids. The product should not be trowelled smooth.

Alternatively, Isover Acoustic insulation can be used in conjunction with DriLyner and appropriate Gyproc board to give improved acoustic performance.

### Fixtures

Lightweight fixtures can be made directly to the lining. For other fixtures, the fixing device used should be long enough to bridge the drylining cavity and give adequate penetration into the solid wall.

▶ Refer to C02. S01. P41 – Service installations.

### Tiling

Tiling should only commence seven days after installation.

For further details on tiling guidance:

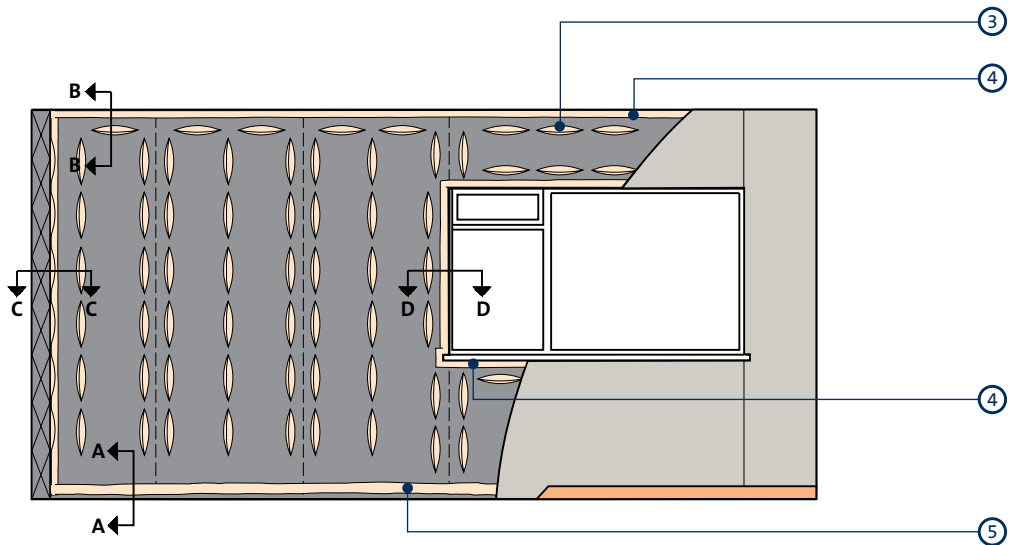
▶ Refer to C08. S04. P498 – Finishes, Tiling.

### Board finishing

▶ Refer to C08. S01. P483 – Finishes.

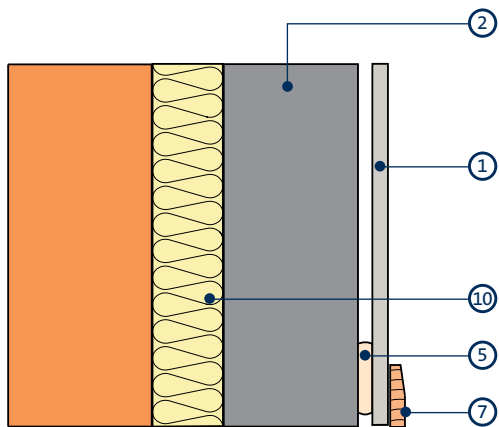
# Drilyner construction details

1



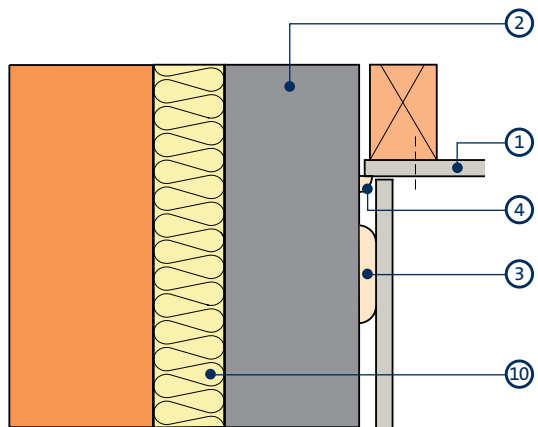
Wall elevation — Gyproc WallBoard 9.5mm and 12.5mm thick, 900mm wide

2



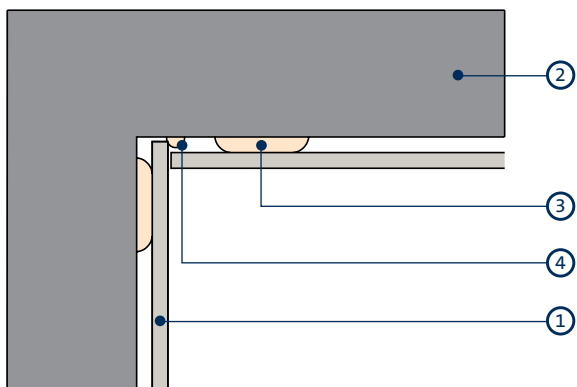
Section A - A

3



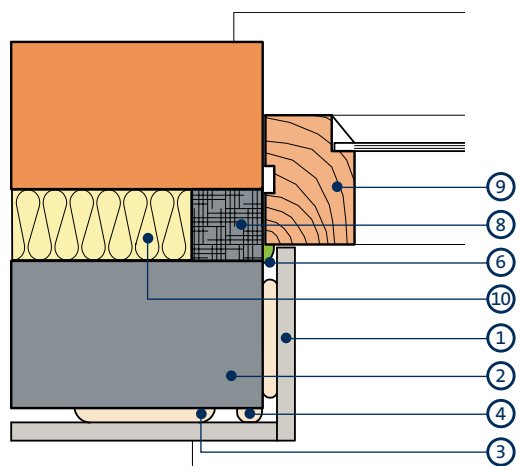
Section B - B

4



Section C - C

5

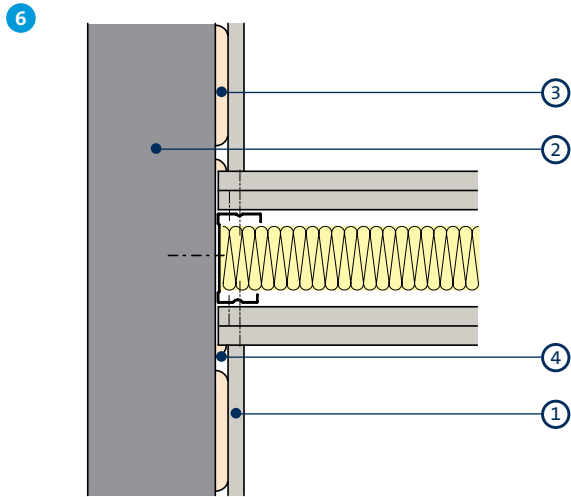


Section D - D

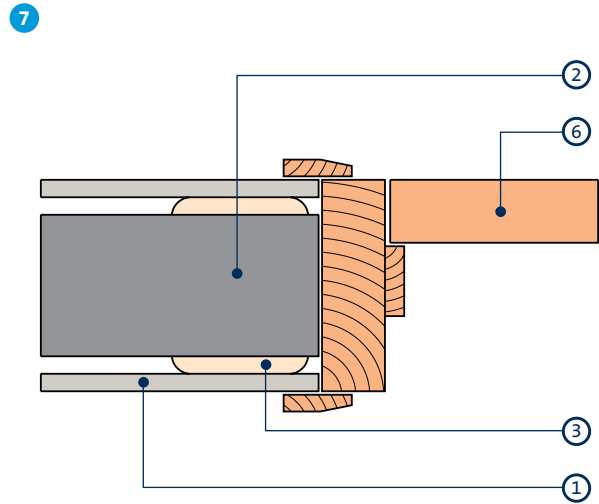
- 1 Gyproc plasterboard
- 2 Masonry wall
- 3 Gyproc Plasterboard Compound dab
- 4 Gyproc Plasterboard Compound fillet
- 5 Gyproc Plasterboard Compound continuous ribbon

- 6 Gyproc Sealant (where required)
- 7 Skirting
- 8 Proprietary cavity closer
- 9 Window unit
- 10 Isovac acoustic insulation

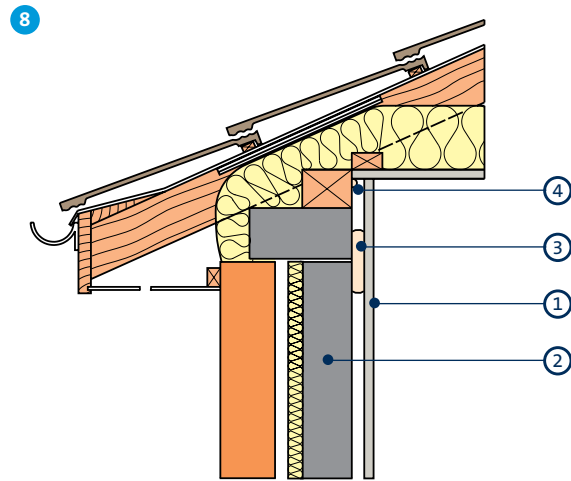
## Drilyner construction details (continued)



Junction with GypWall



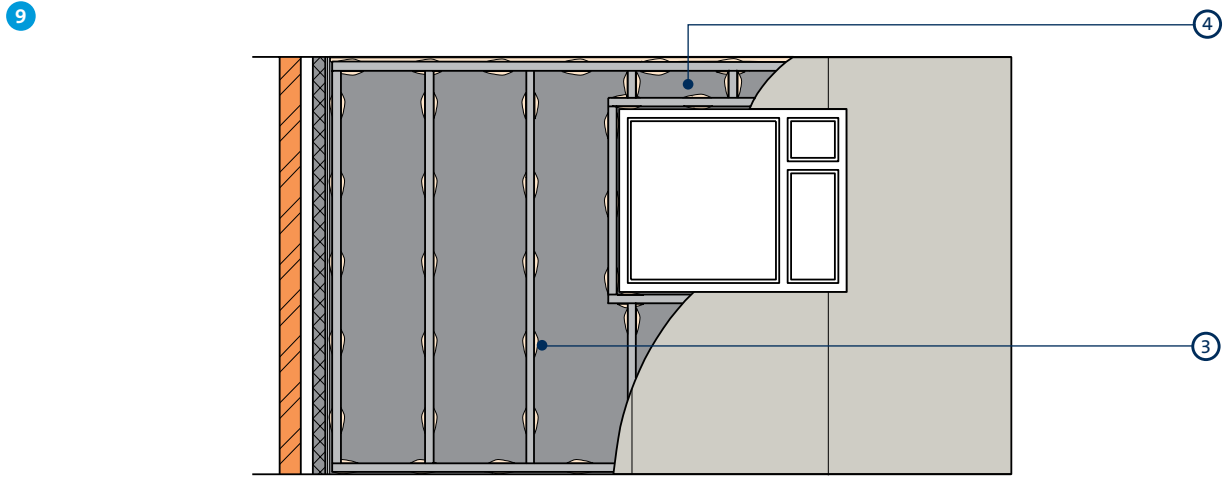
Door frame



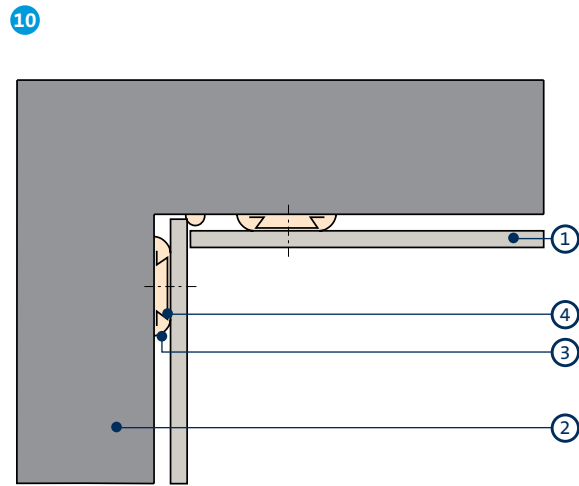
Ceiling to roof junction

- 1 Gyproc plasterboard
- 2 Masonry wall
- 3 Gyproc Plasterboard Compound dab
- 4 Gyproc Plasterboard Compound fillet
- 5 Gyproc Sealant (where required)
- 6 Door assembly

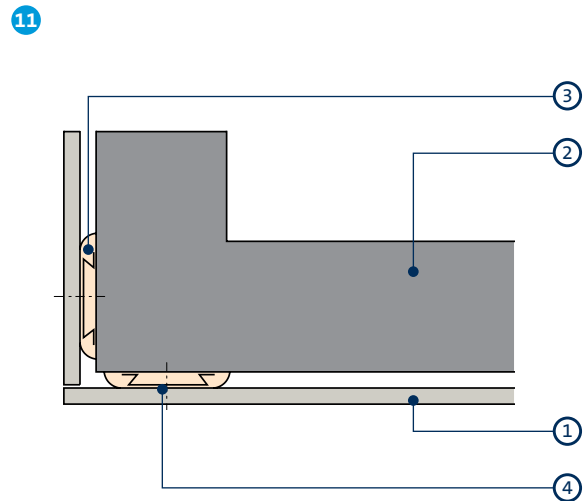
# DriLyner MF construction details



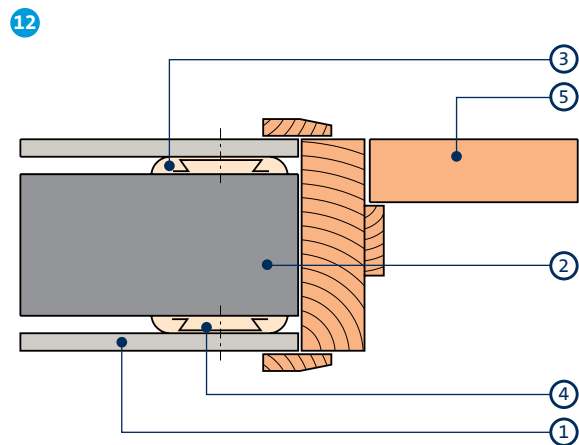
Wall elevation - Gyproc WallBoard, 12.5mm thick, 1200mm wide



Internal angle



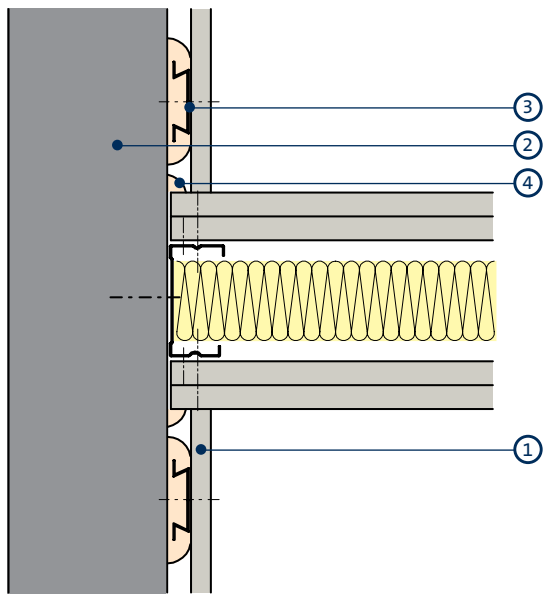
External angle



Door frame

- |   |   |
|---|---|
| <ul style="list-style-type: none"> <li>1 Gyproc plasterboard</li> <li>2 Masonry wall</li> <li>3 Gyproc Plasterboard Compound dab</li> </ul> | <ul style="list-style-type: none"> <li>4 Gypframe MF10 Channel (fixings into channel omitted for clarity)</li> <li>5 Door assembly</li> <li>6 Gyproc Sealant</li> </ul> |
|---|---|

13



Junction with GypWall

- 1 Gyproc plasterboard
- 2 Masonry wall
- 3 Gypframe MF10 Channel (fixings into channel omitted for clarity)
- 4 Gyproc Plasterboard Compound fillet

# Drilyner Wall Linings system components

## Gypframe metal components



### Gypframe MF10 Channel

Vertical support to receive fixing of board.

## Board products



### Gyproc WallBoard

Standard gypsum plasterboard.



### Gyproc WallBoard DUPLEX

Standard gypsum plasterboard, backed with a vapour control layer.



### Gyproc Moisture Resistant

Gypsum plasterboard with moisture resistant additives in the core and special green lining paper for easy recognition.



### Gyproc DuraLine<sup>1</sup>

Gypsum plasterboard with fire resistant additives and a high density core for enhanced sound insulation and impact resistance performance.

<sup>1</sup> Also available in Moisture Resistant (MR) version. MR boards are specified in intermittent wet use areas.

## Fixing products



### Gyproc Drywall Screws

Secondary mechanical fixing for Gyproc laminate in the Drilyner MF systems on masonry walls.

## Plasterboard accessories



### Gyproc Jointing Materials

Jointing compounds, ready mixes and adhesives for reinforcement and finishing of board joints.



### Gyproc Plasterboard Compound

For bonding Gyproc boards (dab fixing) and Gypframe MF10 Channels.



### Gyproc Control Joint

To accommodate structural movement of up to 7mm.



### Gyproc Sealant

Used for fixing boards in the Drilyner MF system and to seal air paths for optimum sound insulation.



### Gyproc Corner Tape

A paper tape bonded to two corrosion resistant steel strips.



### Gyproc Paper Joint Tape

A paper tape designed for reinforcement of flat joints or internal angles.



### Gyproc Drywall Primer

Used to prepare for painting.  
Tub contents 10 litre.

## DriLyner Wall Linings system components (continued)

### Finishing products



#### Gyproc Skimcoat

To provide a plaster skim finish on most common backgrounds including undercoat plasters and plasterboard. Can provide enhanced acoustic performance.



#### Gyproc Carlite Finish

To provide a plaster skim finish on most common backgrounds including undercoat plasters and plasterboard. Can provide enhanced acoustic performance.



#### Gyproc Carlite Ultra Finish

Offers all the benefits of Gyproc Skimcoat and Gyproc Carlite Finish with a reduced set time of 90-120mins, making it ideal for smaller jobs.



#### Gyproc Magnetic Plaster

To provide a plaster skim finish that provides an attraction to magnets used to finish a wide range of backgrounds, including undercoat plasters and plasterboard.



#### Plaster accessories

Designed for the reinforcement and finishing of board joints before plaster skimming.

### Insulation products



#### Isover Acoustic Roll

Glass mineral wool for enhanced thermal performance.

## Drilyner Wall Linings installation overview

This is intended to be a basic description of how the system is built.

### Drilyner



The board edge positions are marked on the wall, and Gyproc Plasterboard Compound is applied to the wall in dabs to support the boards.



A continuous fillet / ribbon of Gyproc Plasterboard Compound is applied to the wall perimeter and around all services and openings as board fixing proceeds. This is particularly important if the lining is designed to act as an air barrier to achieve building airtightness.



Boards are 'tapped' into position.



Lifted tight to the ceiling using a footlifter and supported until the adhesive sets.



Further boards are installed, lightly butted together, to complete the lining.

## DriLyner Wall Linings installation overview (continued)

This is intended to be a basic description of how the system is built.

### DriLyner MF



The board edge and centre positions are marked on the wall and dabs of Gyproc Plasterboard Compound are applied progressively to the wall to each vertical line.

Gypframe MF10 Channels are located onto the adhesive dabs and 'tapped' into position. Horizontal channels are similarly located at the head and base.



At angles and reveals, Gypframe MF10 Channels are installed close to the corner to provide support. Door and window openings are framed with Gypframe MF10 Channels. At window openings, the channel at the head forms a ground for fixing curtain track. Where a partition abuts, an additional Gypframe MF10 Channel is installed to provide a fixing ground. Board fixing can proceed once the adhesive has fully set.



A continuous fillet / ribbon of Gyproc Plasterboard Compound is applied to the wall perimeter and around all services and openings as board fixing proceeds. This is particularly important if the lining is designed to act as an air barrier to achieve building airtightness. Boards are screw-fixed to all Gypframe MF10 Channel supports. Screw lengths should be selected to avoid contact with the masonry background.



### Additional information

For full installation details, refer to the **Gyproc Installation Book**, available to download from [gyproc.ie](http://gyproc.ie)

# Gyplyner

Metal framed wall lining system

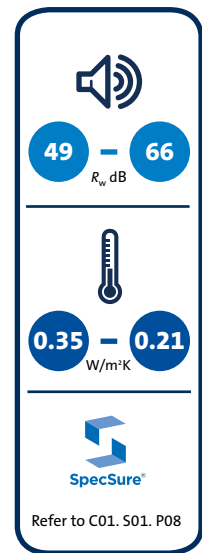


# GypLyner

**GypLyner** is a cost-effective, virtually independent metal wall lining system. This system is commonly used where the external wall or substrate is very uneven or out of plumb.

## Key benefits

- Background surface irregularities are accommodated within the framework cavity
- Provides a solution for backgrounds that are not suitable for bonded systems, for example plasters or **DriLyner** systems
- Services are easily incorporated within the framework
- Minimal thermal bridging of the insulation layer due to the small, discrete fixings back to the substrate
- Provides a thermally responsive environment with quick heating time as a result of positioning the insulation layer on the warm side of the room
- Provides a high performance option to achieve enhanced acoustic performance
- Ideal system for improving a wall's water vapour resistance through the addition of a Gyproc **DUPLEX** board option with integrated vapour control membrane



## You may also be interested in...

### GypLyner iwl

Are you unable to fix back directly to the substrate or looking for even higher levels of sound insulation performance? **GypLyner iwl**, a metal framed wall lining system that only requires fixing at head and base may provide the ideal solution. ▶ Refer to C07. S05. P468 – **GypLyner iwl**.

### GypLyner ceiling system

**GypLyner ceiling** is a general purpose ceiling lining system suitable for most internal applications. It is a versatile system that is suitable for concrete soffits or timber joists, which utilises the same components as the **GypLyner** wall lining system.

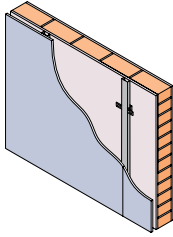
▶ Refer to C06. S03. P376 – **GypLyner**

## Gyplyner performance (continued)

### Upgrading sound insulation of solid internal walls

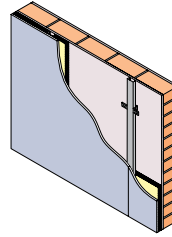
Table 1 – Gyplyner refurbishment

①



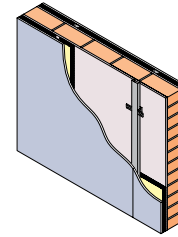
Solid brick wall (103mm) of density 1700 kg/m<sup>3</sup> with 13mm plaster each side and Gyplyner GL1 Lining Channel framework fixed to **one side** to give 35mm cavity. Lining as in table.

②



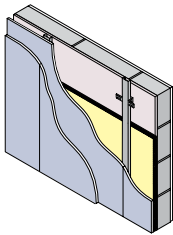
Solid brick wall (103mm) of density 1700 kg/m<sup>3</sup> with 13mm plaster each side and Gyplyner GL1 Lining Channel framework fixed to **one side** to give 35mm cavity. Cavity filled with 25mm Isover Acoustic Roll. Lining as in table.

③



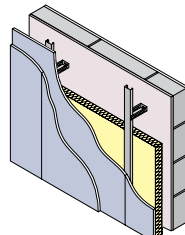
Solid brick wall (103mm) of density 1700 kg/m<sup>3</sup> with 13mm plaster each side and Gyplyner GL1 Lining Channel framework fixed to **both sides** to give 35mm cavities. Cavities filled with 25mm Isover Acoustic Roll. Linings as in table.

④



Solid block wall (100mm), of density 1700 kg/m<sup>3</sup> with 13mm plaster each side. Gyplyner GL1 Lining Channel framework fixed to one side to give 35mm cavity. Cavity filled with 25mm Isover Acoustic Roll. Linings as in table.

⑤



Solid block wall (100mm), of density 1700 kg/m<sup>3</sup> with 13mm plaster each side. Gyplyner GL1 Lining Channel framework fixed to one side to give 85mm cavity. Cavity filled with 50mm Isover Acoustic Roll. Linings as in table.

Detail	Board type	Lining thickness mm	Sound insulation $R_w (R_w + C_{tr})$ dB	Improvement over existing wall <sup>1</sup> $R_w (R_w + C_{tr})$ dB	System reference
①	Gyproc SoundBloc	1 x 12.5	49 (43)	+2 (-1)	B226009
②	Gyproc SoundBloc	1 x 12.5	57 (50)	+10 (+6)	B226008
③	Gyproc SoundBloc	1 x 12.5	60 (42)	+13 (-2)	B226010
④	Gyproc SoundBloc	1 x 12.5	57 (50)	+10 (+6)	B226008
④	Gyproc SoundBloc	2 x 12.5	60 (55)	+13 (+11)	B226003
⑤	Gyproc SoundBloc	1 x 12.5	64 (56)	+17 (+12)	B226007
⑤	Gyproc SoundBloc	2 x 12.5	66 (59)	+19 (+15)	B226005

<sup>1</sup> Existing solid masonry wall (100mm) of density 1700 kg/m<sup>3</sup> with 13mm plaster each side achieved  $R_w$  47dB ( $R_w + C_{tr} + 44$ dB).

**NB** The fire resistance and sound insulation performances are for imperforate partitions, walls and ceilings incorporating boards with all joints taped and filled, or skimmed according to Gyproc's recommendations. The quoted performances are achieved only if Gyproc and Isover components are used throughout, and the Company's fixing recommendations are strictly observed. Any variation in the specifications should be checked with Gyproc.

# GypLyner design

## Building design

The depth of the cavity is determined by the positioning of the Gypframe GL2 or GL9 Brackets, which should be located at 800mm vertical centres and 600mm horizontal centres (to support the Gypframe GL1 Channel).

## Planning – key factors

Allow for a stand-off of 25mm - 75mm plus the lining thickness for Gypframe GL2 Brackets, and 25mm - 125mm plus the lining thickness for Gypframe GL9 Brackets. These stand-offs are sufficient to correct irregularities normally encountered in solid backgrounds. The stand-off will determine the lining dimension required at door and window reveals and soffits. Ceilings should be installed prior to installing GypLyner wall linings. Any abutting partitions should also be installed prior to drylining.



### Important information

Walls must be free from dampness before any GypLyner system can be installed.

## Cavity barriers

Building Regulations may require the provision of vertical cavity barriers to long runs of lining. Minimum 12.5mm plasterboard, cut to cavity depth and screw-fixed to the leg of Gypframe GL1 Lining Channel, will provide a satisfactory cavity barrier.

## Thermal performance

Uncontrolled air movement through the drylining cavity can result in excessive heat loss from the building. The quoted U-values for GypLyner wall lining are based on a sealed cavity between the lining and the background. This is achieved in practice if the abutting elements and the background are well fitted, and junctions are sealed using Gyproc Sealant.

The designer should also specify a method of restricting air movement around the perimeter of suspended timber floors, such as the provision of a flexible seal between the floor and walls.

## Condensation and water vapour resistance

Gyproc WallBoard DUPLEX offers significant resistance to water vapour transmission.

It is important, particularly in new buildings, that external walls are properly dried out before a vapour control layer is provided, otherwise moisture may be trapped, impairing the performance of the construction.

## Wall lining rigidity

Gypframe GL2 or Gypframe GL9 Brackets should be positioned equidistant at maximum 800mm vertical centres. Where there is a requirement for increased rigidity, these support centres should be reduced accordingly, although acoustic performance may be downgraded. Gypframe GL11 GypLyner Anchors are recommended for fixing brackets to the solid background.

## Services

The cavity between the metal framework and the background facilitates the incorporation of services. Pipes and conduits should be fixed in position before installing the framing. Maximum cavity depths (substrate surface to the back of the lining board) of 75mm or 125mm can be achieved using Gypframe GL2 or GL9 Bracket respectively.

## Fixtures

Lightweight fixtures can be made directly to the lining. Medium weight fixtures should be made to Gypframe 99 FC 50 Fixing Channel. Heavyweight fixtures (to BS 5234), such as wash basins and wall cupboards, can be fixed using plywood secured with Gypframe Service Support Plates.

▶ Refer to C02. S01. P41 – Service Installations.

## Board finishing

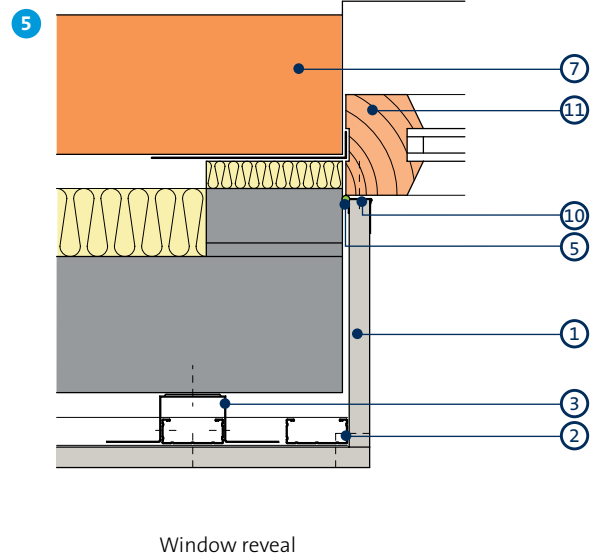
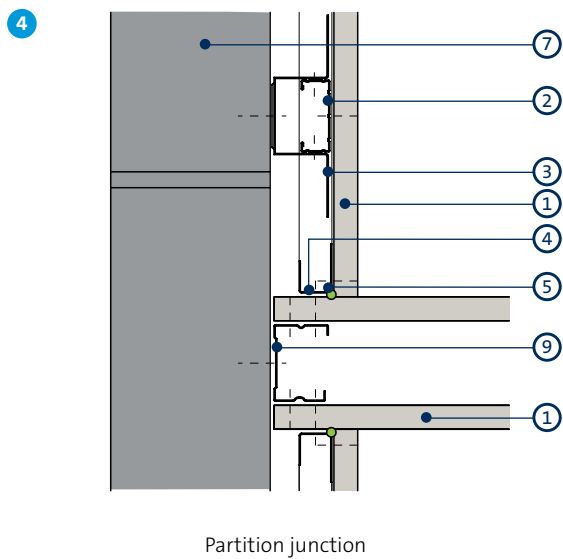
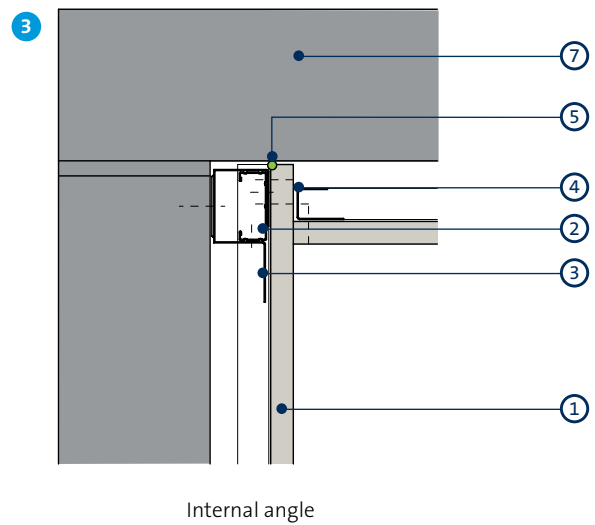
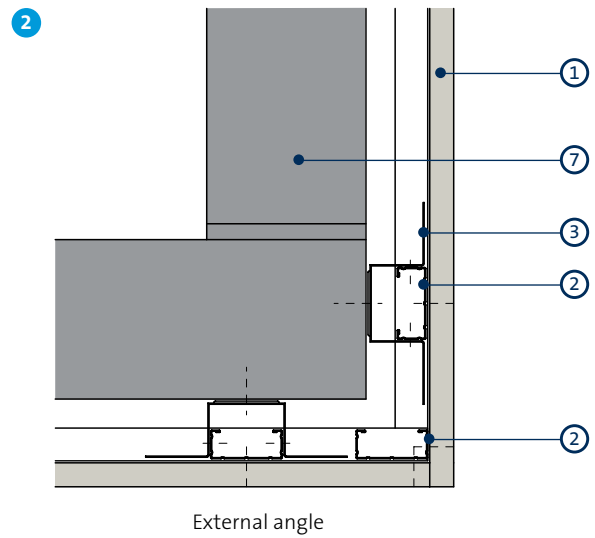
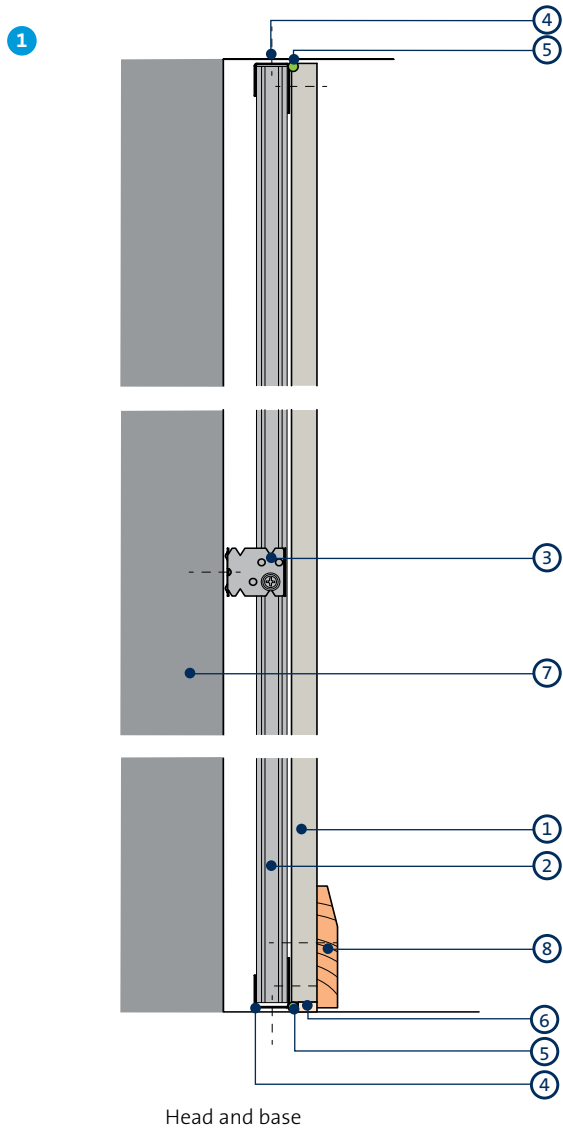
▶ Refer to C08. S01. P483 – Finishes.

## Tiling

Tiles can be applied to the surface of lightweight partition and lining systems. For further details on tiling guidance:

▶ Refer to C08. S04. P498 – Tiling.

# Gyplyner construction details



- 1 Gyproc plasterboard
- 2 Cypframe GL1 Lining Channel
- 3 Cypframe GL2 or GL9 Bracket fixed with Cypframe GL11 GypLyner Anchor
- 4 Cypframe GL8 Track
- 5 Gyproc Sealant

- 6 Bulk fill with Gyproc jointing materials (where gap exceeds 5mm)
- 7 Wall structure
- 8 Skirting
- 9 Gypframe 'C' Stud
- 10 Gyproc Drywall Edge Bead
- 11 Window frame

# Gyplyner system components

## Gypframe metal components



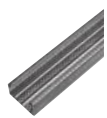
### Gypframe GL8 Track

Floor and ceiling track for retaining the Gypframe GL1 Lining Channel at floor, ceiling, wall, abutments and around openings.



### Gypframe 99 FC 50 Fixing Channel

A versatile metal fixing channel used to support medium weight fixtures on walls.



### Gypframe GL1 Lining Channel

Main support channel to receive fixing of board.



### Gypframe GF51 Fixing Strap

Used to support horizontal board joints.



### Gypframe GL2 Bracket

For connecting the Gypframe GL1 Lining Channel to the structural background with a maximum 75mm stand-off.



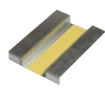
### Gypframe GFT1 Fixing T

Used to support horizontal board joints.



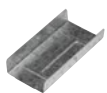
### Gypframe GL9 Bracket

For connecting the Gypframe GL1 Lining Channel to the structural background with a maximum 125mm stand-off



### Gypframe Service Support Plate

For installation of 18mm plywood within a partition cavity to support medium to heavyweight fixtures.



### Gypframe GL3 Channel Connector

For joining two sections of Gypframe GL1 Lining Channel.

## Board products



### Gyproc WallBoard

Standard gypsum plasterboard.



### Gyproc WallBoard DUPLEX

Standard gypsum plasterboard, backed with a vapour control layer.



### Gyproc SoundBloc<sup>1</sup>

Gypsum plasterboard with a high density core for enhanced sound insulation performance.



### Gyproc Duraline<sup>1</sup>

Gypsum plasterboard with fire resistant additives and a high density core for enhanced sound insulation and impact resistance performance.



### Glasroc H TILEBACKER

Non-combustible glass-reinforced gypsum board with a water resistant pre-primed acrylic coating to receive tiling.

<sup>1</sup> Also available in Moisture Resistant (MR) version. MR boards are specified in intermittent wet use areas.

**NB** DUPLEX grade board is used as an external wall lining to control water vapour transmission.

## Gyplyner system components (continued)

### Fixing products



#### Gyproc Drywall Screws

Corrosion resistant self-tapping steel screws for fixing board-to-timber and board-to-metal framing less than 0.8mm thick.



#### Gypframe GL11 Gyplyner Anchors

For fixing Gypframe GL2 and GL9 Brackets to concrete / masonry walls.



#### Gyproc Collated Drywall Screws

Corrosion resistant self-tapping steel screws for fixing board-to-timber and board-to-metal framing less than 0.8mm thick.



#### Gyproc Wafer Head Drywall Screws

Corrosion resistant self-tapping steel screws for fixing metal to metal framing less than 0.8mm thick.

### Plasterboard accessories



#### Gyproc Sealant

Used to seal air paths for optimum sound insulation.



#### Gyproc Jointing Materials

Jointing compounds, ready mixes and adhesives for reinforcement and finishing of board joints.



#### Gyproc Paper Joint Tape

A paper tape designed for reinforcement of flat joints or internal angles.



#### Gyproc Control Joint

To accommodate structural movement of up to 7mm.



#### Gyproc Drywall Primer

Used to prepare for painting.  
Tub contents 10 litre.

### Finishing products



#### Gyproc Skimcoat

To provide a plaster skim finish on most common backgrounds including undercoat plasters and plasterboard. Can provide enhanced acoustic performance.



#### Gyproc Carlite Finish

To provide a plaster skim finish on most common backgrounds including undercoat plasters and plasterboard. Can provide enhanced acoustic performance.



#### Gyproc Carlite Ultra Finish

Offers all the benefits of Gyproc Skimcoat and Gyproc Carlite Finish with a reduced set time of 90-120mins, making it ideal for smaller jobs.



#### Gyproc Magnetic Plaster

To provide a plaster skim finish that provides an attraction to magnets used to finish a wide range of backgrounds, including undercoat plasters and plasterboard.

### Insulation products



#### Isover Acoustic Roll

Glass mineral wool for enhanced acoustic and thermal performance.

# Gyplyner installation overview

This is intended to be a basic description of how the system is built.



Gypframe GL8 Track is fixed to perimeters at 600mm centres with the longer leg towards the lining, using appropriate fixings.



The perimeter of each frame is then sealed with Gyproc Sealant.



Vertical lines are marked on the wall at 600mm intervals to indicate Gypframe GL2 or GL9 Bracket fixing centres. Horizontal lines are marked at 800mm centres to determine individual bracket positions. Gypframe Brackets are then fixed into position.



Gypframe GL1 Lining Channels are friction-fitted into the track, extending if required.



Gypframe Bracket legs are bent forward and each leg fixed to the Gypframe GL1 Lining Channel with Gyproc Wafer Head Drywall Screws.



The protruding Gypframe Bracket legs are bent back to sit clear of the Gypframe GL1 Lining Channel face. At internal angles, a Gypframe GL1 Lining Channel is positioned tight into the corner to provide support for the lining.



Openings and reveals are formed with Gypframe GL1 Lining Channels and Gypframe GL8 Track.



Edge Bead can be fixed to window or door frames to provide edge protection to the reveal and soffit linings.



Gyproc plasterboards are then fixed to all framing members with Gyproc Drywall Screws.



## Additional information

For full installation details, refer to the **Gyproc Installation Guide**, available to download from [gyproc.ie](http://gyproc.ie)

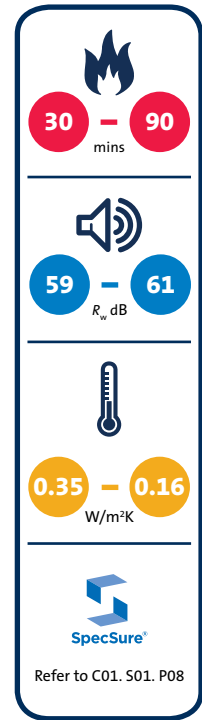
# GyLyner iwl

Independent wall lining system



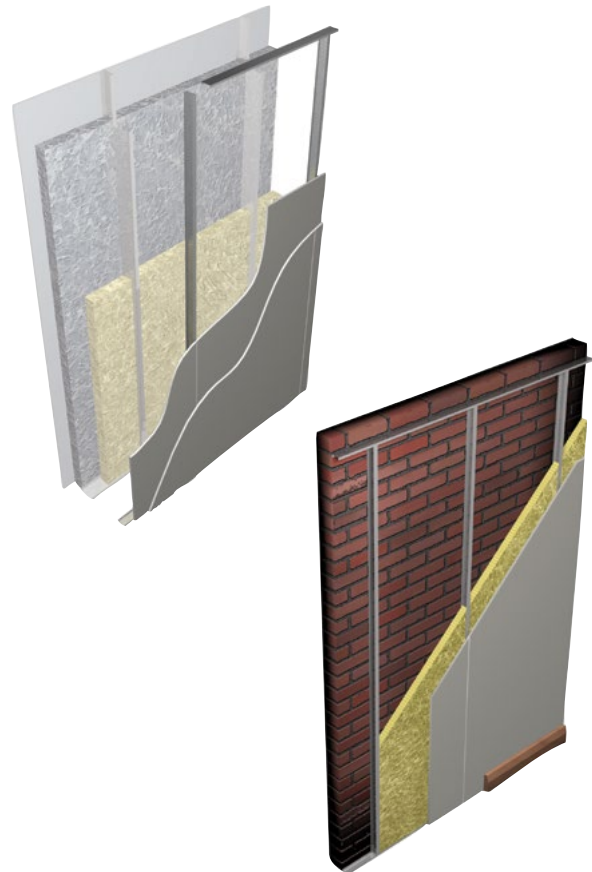
## Gyplyner iwl

**Gyplyner iwl** independent wall lining is a lightweight, non-loadbearing system, which is built independently of the external wall construction. **Gyplyner iwl** is particularly suitable for buildings where fixing into the background is difficult or not possible. The lining provides fire resistance and acoustic upgrades to structural steel sections clad with lightweight metal sheeting, and can also be used within new or existing masonry walls to increase sound insulation and meet stringent thermal performance requirements.



### Key benefits

- Totally independent from wall with fixings to floor and soffit only, particularly suitable for basements with waterproof tanking
- Any surface irregularities within the external wall construction are completely removed through the totally independent framework
- Services are easily incorporated within the framework with no limitation to the cavity size that can be created
- Minimal thermal bridging due to the use of a totally independent framework
- Provides a high-performance option to achieve enhanced acoustic performance and fire protection to steel, in one lining solution



### You may also be interested in...

#### ShaftWall

If you require fire resistance greater than 90 minutes and/or fire resistance in both directions.

► Refer to C05. S02. P291 – **ShaftWall**.



**Table 1a - Gyplyner wall maximum heights<sup>1</sup> for Gypframe 'I' Studs at 600mm centres**

Stud type	12.5mm boards maximum heights		15mm boards maximum heights	
	single mm	double mm	single mm	double mm
Gypframe 48 I 50	2400	2700	2400	2800
Gypframe 60 I 50	2400	3000	2700	3300
Gypframe 60 I 70	3000	3600	3300	3900
Gypframe 70 I 70	3600	4200	3900	4300
Gypframe 92 I 90	5100	5700	5400	5800
Gypframe 146 I 80	6900	7200	7200	7500

**Table 1b - Gyplyner wall maximum heights<sup>1</sup> for Gypframe 'I' Studs at 300mm centres**

Stud type	12.5mm boards maximum heights		15mm boards maximum heights	
	single mm	double mm	single mm	double mm
Gypframe 48 I 50	3000	3400	3000	3600
Gypframe 60 I 50	3000	3800	3400	4300
Gypframe 60 I 70	3800	4500	4200	4900
Gypframe 70 I 70	4500	5200	4900	5500
Gypframe 92 I 90	6400	7100	6800	7200
Gypframe 146 I 80	8700	9000	9100	9500



**Table 1c - Gyplyner wall maximum heights<sup>2</sup> for Gypframe 'I' Studs at 600mm centres**

Stud type	12.5mm boards maximum heights		15mm boards maximum heights	
	single mm	double mm	single mm	double mm
Gypframe 48 I 50	2400	2700	2400	2800
Gypframe 60 I 50	2400	3000	2700	3300
Gypframe 60 I 70	3000	3600	3300	3900
Gypframe 70 I 70	3600	4000	3900	4000

▶ For further assistance in choosing the right solution for your project, try our System Selector; an online tool that enables quick and easy filtering by performance criteria. It provides system specific information downloads including BIM (Revit) objects. Go to [gyproc.ie](http://gyproc.ie)

<sup>1</sup> Based on a limiting deflection of L/240 at 200 Pa.

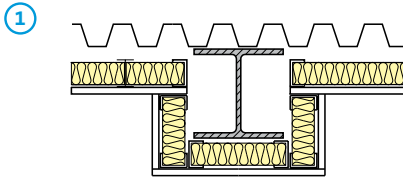
<sup>2</sup> The maximum heights quoted are limited by the fire state field of application or by limiting deflection L/240@200Pa, whichever is the more onerous

**NB** For heights below 4200mm the appropriate Gypframe Folded Edge Standard Floor and Ceiling Channel (FEC) can be used. For heights between 4200mm and 8000mm, Gypframe Deep Flange Floor and Ceiling Channel (EDC) should be used (subject to deflection criteria). For heights above 8000mm, Gypframe Extra Deep Flange Floor and Ceiling Channel (EDC) should be used (subject to deflection criteria).

**NB** The fire resistances apply to external walls, whose construction incorporates structural steel sections with a profiles steel cladding, when the inside of the wall is exposed to fire.



**Table 2 - Solutions to satisfy the requirements of BS EN 1364-1: 1999 and BS 476: Part 22: 1987**



Board linings to one side of Gypframe 'T' Stud framework and 50mm Isover Steel Frame Infill Batts, forming an independent lining to structural steel columns, in association with external steel cladding (0.6mm). Linings as in table.

Detail	Board type	Lining thickness mm	Duty rating	System reference
<b>Fire resistance - 30 minutes integrity<sup>2</sup>: 30 insulation<sup>2,3</sup> EN BS</b>				
1	Gyproc WallBoard	2 x 12.5	Severe	B216003
1	Gyproc SoundBloc	2 x 12.5	Severe	B216003
1	Gyproc WallBoard	2 x 15	Severe	B216004
1	Gyproc SoundBloc	2 x 15	Severe	B216004
<b>Fire resistance - 60 minutes integrity<sup>2</sup>: 30 insulation<sup>2,3</sup> EN BS</b>				
1	Gyproc FireLine	1 x 12.5	Medium	B216025
1	Gyproc FireLine	1 x 15	Heavy	B216026
<b>Fire resistance - 90 minutes integrity<sup>2</sup>: 30 insulation<sup>2,3</sup> EN BS</b>				
1	Gyproc FireLine	2 x 12.5	Severe	B216027
1	Gyproc FireLine	2 x 15	Severe	B216028

▶ For further assistance in choosing the right solution for your project, try our System Selector; an online tool that enables quick and easy filtering by performance criteria. It provides system specific information downloads including BIM (Revit) objects. Go to [gyproc.ie](http://gyproc.ie)

<sup>1</sup> The fire resistances apply to external walls, whose construction incorporates structural steel sections with a profiled steel cladding, when the inside of the wall is exposed to fire.

<sup>2</sup> Where the external wall is more than 1m from the boundary, Building Regulations allow relaxation of the provision for insulation to 15 minutes in certain circumstances.

<sup>3</sup> The figures quoted relate to the complete wall structure including the external cladding. The lining also offers fire protection to steel columns from the lining side, subject to A/V (Hp/A) factor. Refer to table 3.

**NB** The fire resistance and sound insulation performances are for imperforate partitions, walls and ceilings incorporating boards with all joints taped and filled, or skimmed according to Gyproc's recommendations. The quoted performance (from the underside to the ceiling plenum only) are achieved only if Gyproc and Isover components are used throughout, and the Company's fixing recommendations are strictly observed. Any variation in the specification should be checked with Gyproc.

## Gyplyner iwl fire performance (continued)

### Fire protection of structural steel

For details of when to specify fire resistance using EN / BS  
 ▶ Refer to C02. S01. P18



**Table 3 - Solutions to satisfy the requirements of DD ENV 13381-2: 2002 and BS 476: Part 21: 1987**

Board type	Lining thickness mm	Fire protection mins	Section factor <sup>1</sup> A/V (Hp/A)m <sup>-1</sup>
Gyproc FireLine	1 x 12.5	30	Up to 300
Gyproc WallBoard or Gyproc SoundBloc	2 x 12.5	30	Up to 300
Gyproc FireLine	1 x 12.5	60	Up to 165 (BS only)
Gyproc FireLine	2 x 12.5	60	Up to 300
Gyproc SoundBloc	2 x 15	60	Up to 300
Gyproc FireLine	2 x 12.5	90	Up to 200 (BS only)
Gyproc FireLine	2 x 15	90	Up to 300

▶ For further assistance in choosing the right solution for your project, try our System Selector; an online tool that enables quick and easy filtering by performance criteria. It provides system specific information downloads including BIM (Revit) objects. Go to [gyproc.ie](http://gyproc.ie)

<sup>1</sup> Based on four-sided exposure. Protection is afforded to universal column sections as described in BS 4: Part 1. Based on critical temperature 550°C (information on other critical temperatures is available). A 10mm air gap is required between the back of the board and the face of the structural steel.

**NB** The fire resistance and sound insulation performances are for imperforate partitions, walls and ceilings incorporating boards with all joints taped and filled, or skimmed according to Gyproc's recommendations. The quoted performance (from the underside to the ceiling plenum only) are achieved only if Gyproc and Isover components are used throughout, and the Company's fixing recommendations are strictly observed. Any variation in the specification should be checked with Gyproc.



### You may also be interested in...

If you require steel sections to be encased individually the following options are available:

#### Gyplyner ENCASE

For protection to structural steel for up to 180 minutes.

▶ Refer to C03. S03. P91 – Gyplyner ENCASE

#### FireCase

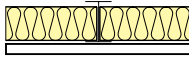
For frameless protection to structural steel for up to 120 minutes.

▶ Refer to C03. S02. P71 – FireCase

# Gyplyner iwL acoustic performance

## Linings for sound insulation

①



Solid brick wall (103mm) of density 1700kg/m<sup>3</sup> with single or double layer board to one side of Gyprock 'I' Stud framework and 50mm Isover Steel Frame Infill Batts forming an independent lining. Linings as in table.

Detail	Board type	Lining thickness mm	Sound insulation <sup>2</sup> $R_w (R_w + C_{tr})$	Duty rating	Approx. weight kg/m <sup>2</sup>	System reference
①	Gyproc WallBoard	1 x 12.5	59 (51)	Medium	11	B216001
①	Gyproc WallBoard	1 x 15	59 (51)	Medium	13	B216002
①	Gyproc WallBoard	2 x 12.5	61 (54)	Severe	20	B216031
①	Gyproc WallBoard	2 x 15	61 (54)	Severe	23	B216033

► For further assistance in choosing the right solution for your project, try our System Selector; an online tool that enables quick and easy filtering by performance criteria. It provides system specific information downloads including BIM (Revit) objects. Go to [gyproc.ie](http://gyproc.ie)

<sup>1</sup> The fire resistance quoted is that provided by the masonry wall without contribution from the lining.

<sup>2</sup> Existing solid masonry wall of density 1700kg/m<sup>3</sup> achieving  $R_w$  45dB prior to lining, and with a 10mm cavity between masonry and back of metal framing.

**NB** The sound insulation performances are for imperforate partitions, walls and ceilings incorporating boards with all joints taped and filled, or skimmed according to Gyproc's recommendations. The quoted performance (from the underside to the ceiling plenum only) are achieved only if Gyproc and Isover components are used throughout, and the Company's fixing recommendations are strictly observed. Any variation in the specification should be checked with Gyproc Technical Department.

## Building design

Whilst Gyplyner iwl lining systems are non-loadbearing, they are able to provide resistance to levels of horizontal non-uniformly distributed loads.

▶ Refer to C02. S01. P37 – Robustness.

## Planning - key factors

Gyplyner iwl comprises of Gyprframe 'I' Studs installed at 600mm centres within Gyprframe Floor & Ceiling Channels to receive board to one side. The position of services should be pre-determined and their installation planned into the frame erection stage. It is important that all parts of the lining system, including the thermal insulation, should remain independent of the external walling. The lining is erected with the external walling in place and the windows and doors fixed.



### Important information

Walls must be free from damp before the Gyplyner iwl system can be installed.

## Extended heights

Where the wall height exceeds the available length of the Gyprframe 'I' Stud, sections of stud can be spliced together to the required length using 600mm lengths of the appropriate floor and ceiling channel, fixed with four Gyproc Wafer Head Drywall Screws in each flange to each side.

▶ Refer to construction detail 2.

Where greater heights than listed in table 1a and 1b are required, it may be possible to brace the lining back to the structure. Note that the system is non-loadbearing and should not be used to provide lateral restraint to masonry or other external wall constructions.

## Junction with a suspended ceiling

Where a Gyplyner iwl system is to be fixed to the framework of a CasoLine mf ceiling, in accordance with Gyproc's installation instructions, it's permissible maximum height is equal to that of where it is fixed direct to a structural soffit of the same height.

In situations where a Gyplyner iwl system passes through a CasoLine mf ceiling, which is to one side of the lining and appropriately fixed to both this lining and perimeter partitions / walls, consideration can be given to the lateral restraint provided by the ceiling when developing the lining specification.

The relevant maximum height is the greater of the floor to CasoLine mf ceiling or ceiling to structural soffit height. Care should be taken during installation of tall linings so as to not adversely affect their performance.

## Acoustic performance

Gyplyner iwl can be used as an independent lining to improve the sound insulation of new or existing masonry walls. Acoustic testing on a basic masonry wall construction achieving  $R_w$  45dB sound insulation gave a 14dB improvement when the wall was lined with Gyplyner iwl. A 16dB improvement was achieved with a double layer lining incorporating Isover insulation. Refer to table 4. Careful detailing is required at junctions with sound insulating partitions in order to maintain acoustic performance.

▶ Refer to construction detail 6.

## Cavity fire barriers

Cavity fire barriers should be included where necessary. If both sides of the cavity are formed by non-combustible or Class 0 materials, barriers are necessary only every 20m. The nature of the barrier and its fixing should not detract from the general performance of the wall.

## Fixing floor and ceiling channels

Gyprframe Floor & Ceiling Channels must be securely fixed with a row of fixings at 600mm maximum centres. For 94mm and 148mm channels, two rows of staggered fixings are required, each row at 600mm centres and each fixing 25mm in from the flange. If the floor is uneven, a 38mm thick timber sole plate equal to the width of the channel should be used.

If the concrete or screeded floor is new, consideration should be given to the installation of a damp-proof membrane between the floor surface and the channel or sole plate.



### Important information

The inclusion of control joints should be considered.

▶ Refer to C02. S01. P39 – Robustness, and construction details 7-8 within this section.

### Deflection heads

The system can accommodate deflection at the head with suitable detailing incorporating Gypframe Deep Flange or Extra Deep Flange Floor & Ceiling Channels.

▶ Refer to C02. S01. P23 and C07. S05. P508 – construction detail 4.

### Damp or rain penetration

In refurbishment projects, where damp or rain penetration may exist, normal corrective measures, such as a new damp course, tanking, or external wall coating, must be taken prior to the installation of the dry internal lining. The cavity between the external wall and the lining system could be drained and ventilated to the outside.

### Thermal performance

Uncontrolled air movement through the drylining cavity can result in excessive heat loss from the building. This can be reduced in practice if the abutting elements and the background are well fitted, and junctions are sealed. The designer should also specify a method of restricting air movement around the perimeter of suspended timber floors, such as the provision of a flexible seal between the floor and walls.

### Condensation and water vapour resistance

Gyproc WallBoard DUPLEX offers additional resistance to water vapour transmission.

The use of Gyproc WallBoard DUPLEX with integral vapour control significantly reduces the risk of interstitial condensation.

It is important, particularly in new buildings, that external walls are properly dried out before a vapour control layer is provided, otherwise moisture may be trapped, impairing the performance of the construction.

### Insulation

Isover Steel Frame Infill Batts are inserted to a friction-fit within the stud cavity. The slabs are self-supporting, receiving internal support from the stud flanges, except where 50mm insulation is fitted into Gypframe 92 I 90 or 146 I 80 'I' Studs. In this case, a 150mm x 50mm strip of Isover Steel Frame Infill Batts is inserted to retain the slab. With Gypframe 146 I 80 'I' Stud, two strips of insulation should be inserted to retain the slab.

### Services

The stud cut-outs can be used for services provided that the Isover insulation remains in place. The positioning of stud cut-outs is shown in construction detail 1.

Surface mounted services should be located against the plasterboard lining, and fixed through the lining to the stud framework. Any interruptions in the lining integrity will downgrade its performance. The installation of electrical services should be carried out in accordance with BS 7671.

### Fixtures

Lightweight fixtures can be made directly to the partition linings. Medium weight fixtures can be made to Gypframe 99 FC 50 Fixing Channel. Heavyweight fixtures (to BS 5234), such as wash basins and wall cupboards, can be fixed using plywood secured with Gypframe Service Support Plates.

▶ Refer to C02. S01. P41 – Service installations.

### Board finishing

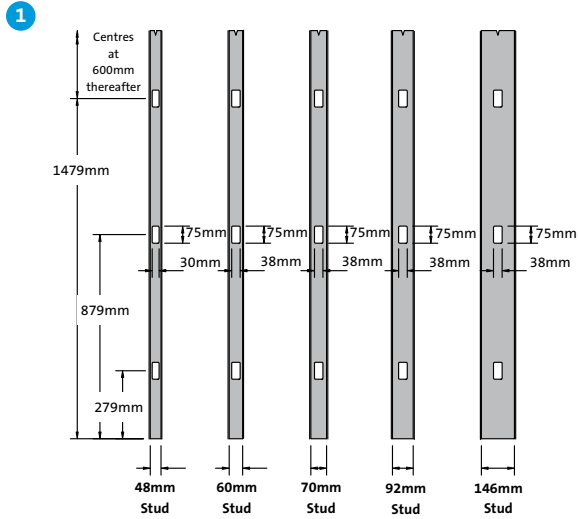
▶ Refer to C08. S01. P483 – Finishes.

### Tiling

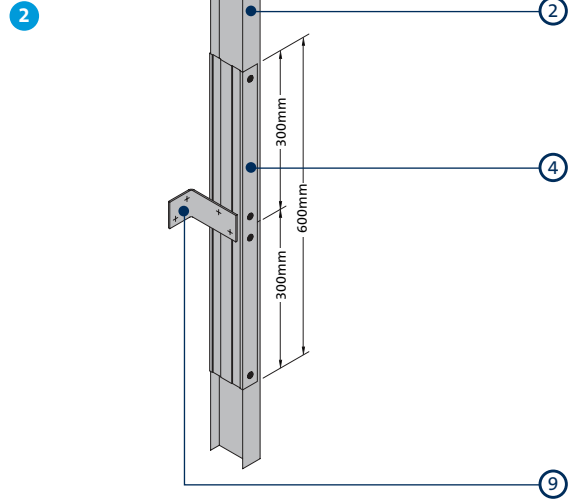
Tiles up to 32kg/m<sup>2</sup> can be applied to the surface of lightweight wall lining systems. For further details on tiling guidance:

▶ Refer to C08. S04. P498 – Tiling.

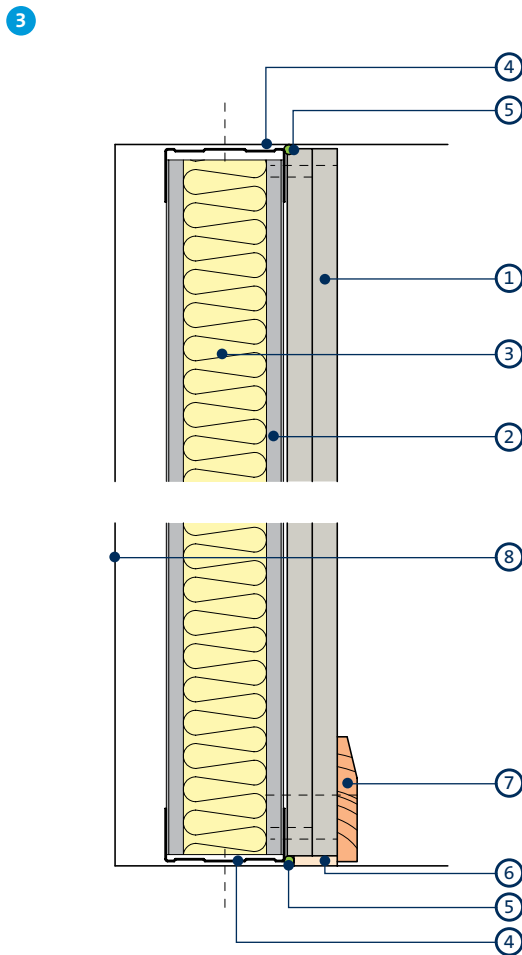
# Gypliner w.l. construction details



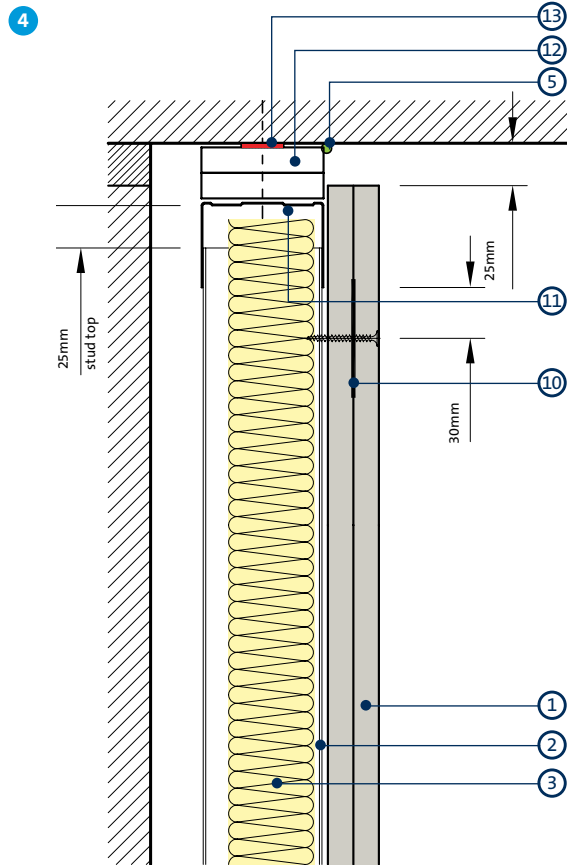
Service cut-outs - Gypframe 'C' Studs and Gypframe 'I' Studs



Gypframe 'I' Stud / splicing and bracing



Head and base

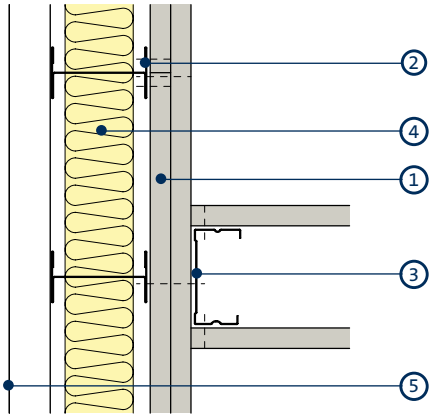


25mm deflection head - BS 476 Part 22: 1987

- 1 Gyproc plasterboard
- 2 Gypframe 'I' Stud
- 3 Isover Acoustic Insulation
- 4 Gypframe Folded Edge Standard Floor & Ceiling Channel
- 5 Gyproc Sealant
- 6 Bulk fill with Gyproc jointing materials (where gap exceeds 5mm)
- 7 Skirting

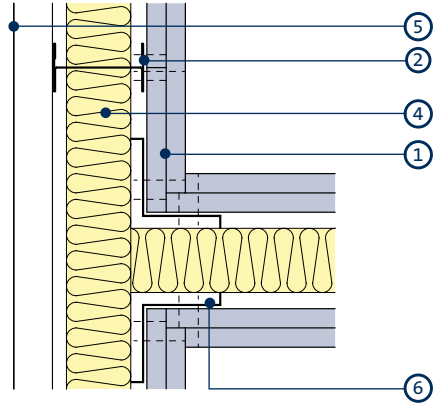
- 8 Wall structure
- 9 Suitable size angle brace by others
- 10 Gypframe GSF1 Fixing Strap
- 11 Gypframe 72 DC 60 Deep Flange Floor & Ceiling Channel
- 12 Glasroc F FIRECASE
- 13 Gyproc FireStrip

5



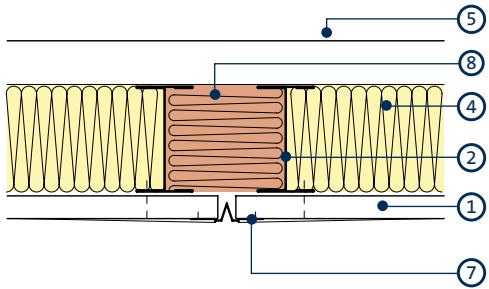
Partition junction

6



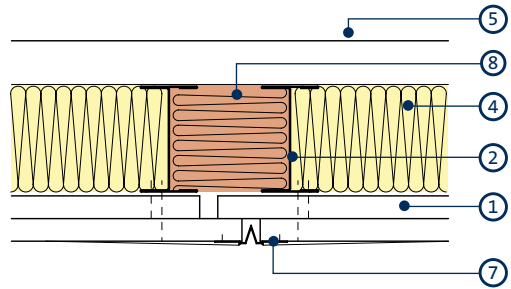
Partition junction to optimise acoustic performance and reduce flanking transmission

7



Gyproc control joint - single board

8



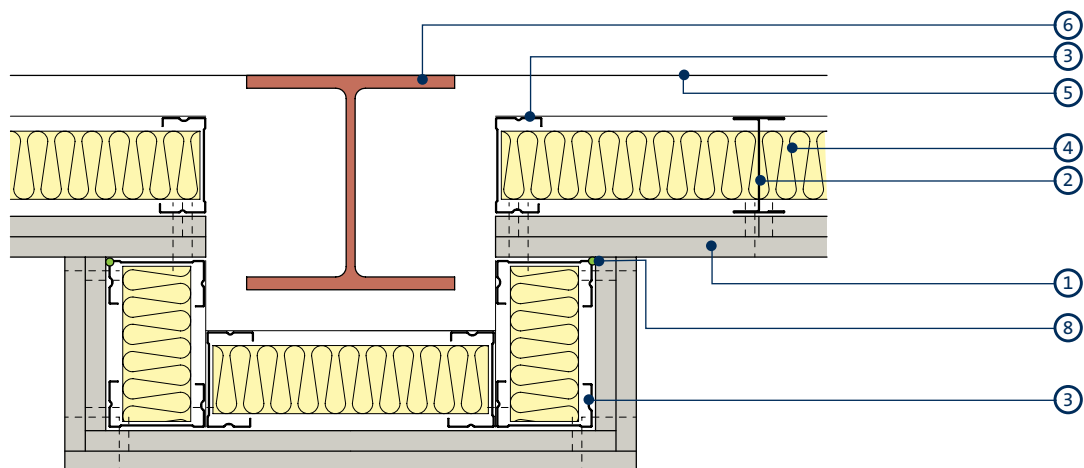
Gyproc control joint - double board

- 1 Gyproc plasterboard
- 2 Gyframe 'I' Stud
- 3 Gyframe 'C' Stud
- 4 Isover Acoustic insulation

- 5 Wall structure
- 6 Gyframe GA5 Internal Fixing Angle
- 7 Gyframe Control Joint
- 8 Stone mineral wool

## Gyplyner iwl construction details (continued)

9

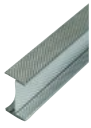


Lining around steel column

- 1 Gyproc plasterboard
- 2 Gypframe 'I' Stud
- 3 Gypframe 'C' Stud
- 4 Isover Acoustic Insulation

- 5 Wall structure
- 6 Steel column
- 7 Concrete column
- 8 Gyproc Sealant

## Gypframe metal components



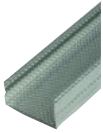
### **Gypframe 'I' Studs (48 I 50, 60 I 50, 60 I 70, 70 I 70, 92 I 90, 146 I 80)**

Enhanced strength stud that allows for lining height, without increasing lining width. Designed to receive fixing of board to one side only.



### **Gypframe 99 FC 50 Fixing Channel**

A versatile metal fixing channel used to support medium weight fixtures on walls.



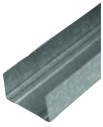
### **Gypframe 'C' Studs (48 S 50, 60 S 50, 70 S 50, 92 S 50, 146 S 50)**

Vertical stud providing acoustic and structural performances designed to receive fixing of board. Used at openings and abutments.



### **Gypframe GFS1 Fixing Strap**

Used to support horizontal board joints.



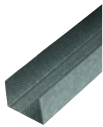
### **Gypframe Folded Edge Standard Floor & Ceiling Channels (50 FEC 50, 62 FEC 50, 72 FEC 50, 94 FEC 50, 148 FEC 50)**

Standard floor and ceiling channels for retaining the Gypframe studs at floor and ceiling junctions and around openings to heights not exceeding 4200mm.



### **Gypframe GFT1 Fixing T**

Used to support horizontal board joints. Best suited for single board solutions.



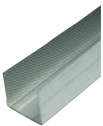
### **Gypframe Deep Flange Floor & Ceiling Channels (50 DC 60, 62 DC 60, 72 DC 60, 94 DC 60, 148 DC 60)**

Floor and ceiling channels with deep flanges for retaining the Gypframe studs at floor and ceiling junctions for partitions 4200mm to 8000mm high. Also used around openings and in deflection heads (maximum 30mm deflection).



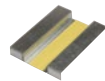
### **Gypframe GA5 Internal Fixing Angle**

Steel angle providing framing stability and board support.



### **Gypframe Extra Deep Flange Floor & Ceiling Channels (50 EDC 70, 72 EDC 80, 94 EDC 70, 148 EDC 80)**

Floor and ceiling channels with extra deep flanges for retaining the Gypframe studs at floor and ceiling junctions for partitions over 8000mm high. Also used around openings and in deflection heads (maximum 50mm deflection).



### **Gypframe Service Support Plate**

For installation of 18mm plywood within a partition cavity to support medium to heavyweight fixtures.

## Gyplyner iwL system components (continued)

### Board products



#### Gyproc WallBoard<sup>2</sup>

Standard gypsum plasterboard.



#### Glasroc H TILEBACKER

Non-combustible glass-reinforced gypsum board with a water resistant pre-primed acrylic coating to receive tiling.



#### Gyproc FireLine<sup>1,2</sup>

Gypsum plasterboard with fire resistant additives.



#### Glasroc F FIRECASE

Non-combustible glass-reinforced gypsum board. Used to form deflection head.



#### Gyproc SoundBloc<sup>1</sup>

Gypsum plasterboard with a high density core for enhanced sound insulation performance.



#### Gyproc Duraline<sup>1</sup>

Gypsum plasterboard with fire resistant additives and a high density core for enhanced sound insulation and impact resistance performance.

<sup>1</sup> Also available in Moisture Resistant (MR) version. MR boards are specified in intermittent wet use areas.

<sup>2</sup> Also available in DUPLEX grades where vapour control is required.

### Fixing products



#### Gyproc Drywall Screws

Corrosion resistant self-tapping steel screws for fixing board-to-timber and board-to-metal framing less than 0.8mm thick. ("I" studs less than 0.6mm thick)



#### Gyproc Collated Drywall Screws

Corrosion resistant self-tapping steel screws for fixing board-to-timber and board-to-metal framing less than 0.8mm thick. ("I" studs less than 0.6mm thick)



#### Gyproc Jack-Point Screws

For fixing boards to Gyproframe metal framing 0.8mm thick or greater ('I' studs 0.6mm thick and greater).



#### Gyproc Wafer Head Drywall Screws

Corrosion resistant self-tapping steel screws for fixing metal to metal framing less than 0.8mm thick ('I' studs less than 0.6mm thick).



#### Gyproc Wafer Head Jack-Point Screws

Corrosion resistant self-tapping steel screws for fixing metal to metal framing 0.8mm thick or greater ('I' studs 0.6mm thick and greater).

## Gypliner IWL system components (continued)

### Plasterboard accessories



#### Gyproc Sealant

Used to seal air paths for optimum sound insulation.



#### Gyproc Control Joint

To accommodate structural movement of up to 7mm.



#### Gyproc Jointing Materials

Jointing compounds, ready mixes and adhesives for reinforcement and finishing of board joints.



#### Gyproc FireStrip

A soft extruded linear intumescent gap sealer to maintain fire resistance located directly to the underside of the soffit when forming a deflection head.



#### Gyproc Drywall Primer

Used to prepare for painting.  
Tub contents 10 litre.



#### Gyproc Paper Joint Tape

A paper tape designed for reinforcement of flat joints or internal angles.

### Finishing products



#### Gyproc Skimcoat

To provide a plaster skim finish on most common backgrounds including undercoat plasters and plasterboard. Can provide enhanced acoustic performance.



#### Gyproc Carlite Finish

To provide a plaster skim finish on most common backgrounds including undercoat plasters and plasterboard. Can provide enhanced acoustic performance.



#### Gyproc Carlite Ultra Finish

Offers all the benefits of Gyproc Skimcoat and Gyproc Carlite Finish with a reduced set time of 90-120mins, making it ideal for smaller jobs.



#### Gyproc Magnetic Plaster

To provide a plaster skim finish that provides an attraction to magnets used to finish a wide range of backgrounds, including undercoat plasters and plasterboard.

### Insulation products

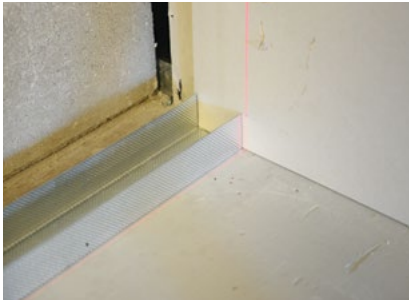


#### Isover Steel Frame Infill Batts

Glass mineral wool for enhanced acoustic and thermal performance.

## Gyplyner IW1 installation overview

This is intended to be a basic description of how the system is built.



Gypframe Floor & Ceiling Channels are suitably fixed to the floor and soffit. Gypframe 'C' Studs are suitably fixed to openings and abutments.



Gypframe 'T' Studs are friction-fitted vertically at the required centres within the channel sections to form the framework. Additional framing is installed as required to support heavy fixtures.



The perimeter of each frame is then sealed with Gyproc Sealant.



If specified, Isover acoustic insulation is fitted between studs. Electrical and other services are normally installed at the frame erection stage. Horizontal runs are fixed to the background or can be routed through cut-outs in the studs.

Gypframe 99 FC 50 Fixing Channel can be installed between studs to support recessed switch boxes / socket outlets.



Boards are screw-fixed to framing members to form the lining. Horizontal board joints should be backed with Gypframe GFS1 Fixing Strap or Gypframe GFT1 Fixing 'T'.



### Additional information

For full installation details, refer to the **Gyproc Installation Guide**, available to download from [gyproc.ie](http://gyproc.ie)

C O 8

Finishes

# Finishes

Essential to all our high performance systems is our full range of finishing products



## Finishes

Gyproc's range of finishes provide everything needed to complete the wall lining, partition, floor and ceiling systems, regardless of the size and complexity of the project specification.

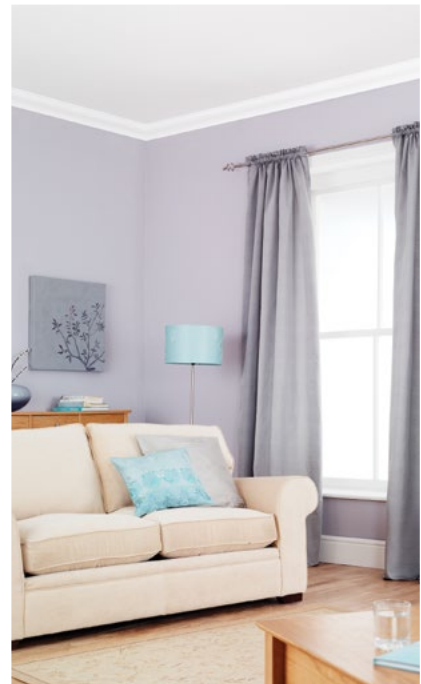
Plaster skimming to plasterboard is a popular method of providing a smooth, seamless surface ready to receive decorative treatment.

Alternatively our jointing materials produce durable joint reinforcement and a smooth, continuous, crack-resistant surface ready for priming and final decoration.

The range of boards available for tiling offers flexibility of design and peace of mind when installed in both wall linings and lightweight partition systems.

To relieve flat runs of lining, joints and angles, and to enhance walls and ceilings, a variety of decorative effects are available which can be installed simply and quickly.

- Plaster skimming - C08. S02. P511
- Jointing - C08. S03. P517
- Tiling - C08. S04. P523
- Decorative effects - C08. S05. P531



### You may also be interested in...

If you are looking for finishes with high sustainability credentials then Gyproc plasters have attained *BES 6001* 'Very Good'. We have also developed EPDs for a number of our plasters' range.

► Refer to C02. S01. P57 – Sustainability.

## Plaster skimming

Plaster skimming to plasterboard is a popular method of providing a smooth, seamless surface ready to receive decorative treatment

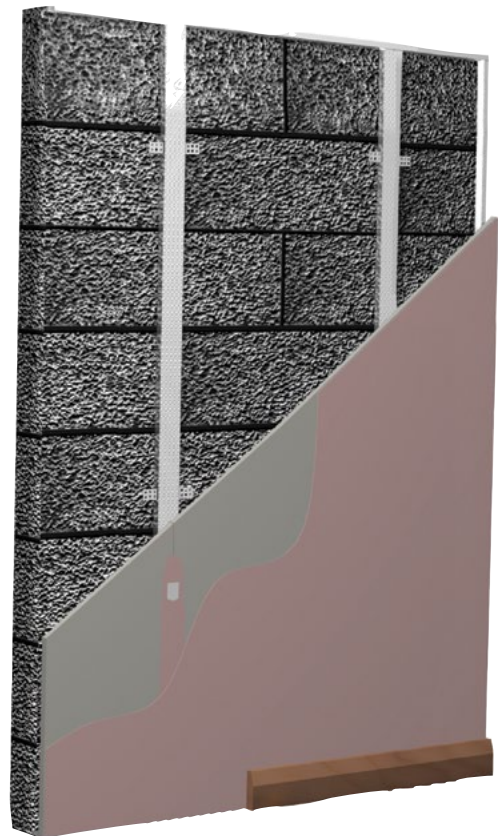


# Plaster skimming

Skim plastering gives many of the advantages of a traditional solid plaster finish such as robustness, acoustic enhancement and a quick turnaround on site.

## Key benefits

- Surfaces are finished in one visit to site
- A smooth and uniform finish can be achieved in one visit to site using our Gyproc plaster range
- Enhanced acoustic performance is achieved by using Gyproc Finish Plasters on a range of GypWall systems



## Additional information

Whatever your requirement, the flexibility of plaster skimming can be used in conjunction with a wide range of system solutions

# Plaster skimming performance

## Reaction to fire

All Gyproc Finish Plasters achieve a Euroclass A1 reaction to fire rating. This makes them an appropriate finish for almost all situations.

► Refer to C02. S01. P16 – Fire.

**Table 1 – Physical properties**

Plaster category	Plaster type	Bag weight kg	Approx. coverage m <sup>2</sup> (based on 2mm thickness)		Approximate setting time hours
			per 1000kg	per bag	
Essential	Gyproc Skimcoat	25	375	9.4	2 - 3
	Gyproc Carlite Finish	25	375	9.4	2 - 3
	Gyproc Carlite Ultra Finish	25	375	9.4	2
Specialist	Gyproc Magnetic Plaster	25	200 <sup>1</sup>	5 <sup>1</sup>	1.5

<sup>1</sup>Based on 3mm thickness.

## Sound insulation

The application of Gyproc Finish Plasters can help the plasterboard element to achieve optimum acoustic performance. They do this in two ways:

- A change to the measured acoustic performance, by applying 2mm Gyproc finishing plasters to both sides of certain GypWall partitions, has a positive effect on the sound insulation rating. This benefit results in a performance uplift of up to  $R_w$  2dB
- Any small gaps or other air paths will be sealed during plastering, limiting flanking routes for sound transfer

This is effective on partitions that are limited by their high frequency performance (coincidence region). This application will also add mass to the partition, which has a positive effect on the mid-frequency of the spectrum.

► Refer to C02. S01. P31 – Building acoustics.

## Stability

Gyproc Finish Plasters attain high strength during the drying process and do not suffer from inherent shrinkage cracks.

## Quality of finish

Homeowners and building occupiers are quick to notice a poor quality finish. Gyproc finishing plasters, are capable of providing a superior, smooth surface whether you're skimming on plasterboard or using a two-coat plaster system. And it's ready to take whatever decorative treatment you choose.

► Refer to C07. S02. P434 – Plaster systems.

## Damage resistance

A skim finish not only provides a better finish, it is also more robust, providing additional resistance to damage in high traffic areas or rooms subject to greater wear and tear. Gyproc finishing plaster provides additional resistance to accidental damage, glancing impacts and repeated abrasion, which can cause scratching, gouging or chipping of other wall finishes. Using Gyproc finishing plaster reduces the extent and frequency of repair work, and minimises associated costs and disruption. It also has excellent adhesion, therefore damage to small areas does not spread or cause debonding, which makes repair easier.

## Gyproc Magnetic Plaster

Can be applied to new or existing walls. Applied with a minimum 3mm thickness it can be decorated with standard emulsion paint or combined with specialist decorative finishes, including blackboard and whiteboard paint or wallpaper.



## Plaster skimming design (continued)

### Planning - key factors

Care must be taken when applying finish coats in low temperatures and an allowance made for slightly longer setting and drying times. Plasters must only be applied where backgrounds are not frozen or will remain at 5°C or above until dry.

### Backgrounds

#### Plasterboards (excluding moisture resistant grade boards)

Skimming should be specified only on the face of boards, i.e. the side without a paper overlap. This will be the ivory face in the case of Gyproc WallBoard and Gyproc DuraLine and the coloured face of Gyproc FireLine, Gyproc SoundBloc, Gyproc WallBoard Premium and Gyproc Habito. Joints must be reinforced. For greatest resistance to cracking this should be carried out using Gyproc Paper Joint Tape.

While the tape and jointing process using Gyproc Paper Joint Tape bedded into an appropriate Gyproc jointing filler remains our best practice recommendation and offers a higher quality and stronger joint, *Gyproc systems may also achieve their stated fire, sound insulation and duty performance claims using a full surface treatment of 2mm Gyproc finishing plasters, applied as per Gyproc's current recommendations, over scrim taped joints; in lieu of the tape and jointing process using Gyproc Paper Joint Tape bedded into an appropriate Gyproc jointing filler.*

#### Glasroc F MULTIBOARD, Glasroc F FIRECASE and Rigidur

Skim finishing should be applied to the smooth face of the board. Rigidur needs to be treated with diluted Gyproc GypPrime prior to skimming to control the suction. Application techniques and joint reinforcement are similar to those used on plasterboards.

#### Moisture resistant grade boards

Skim plastering is not normally specified to Gyproc Moisture Resistant and MR grade boards. These types of board are intended for use in environments of higher than normal humidity for which no gypsum plaster is designed to be suitable.

Where moisture resistant board options are used in shell and core construction to provide temporary resistance to high moisture conditions, they can be skimmed at a later date after the building envelope has been made weather-tight. Likewise, moisture resistant

board can be skimmed where they are being used for convenience and are away from wet areas. Tiling is not recommended on plaster skimmed plasterboard. Application techniques and joint reinforcement are the same as those used on plasterboards. Plaster should be applied only to the face of moisture resistant boards. Pre-treatment with ThistleBond-it is required when using Gyproc Finish Plasters.

# Plaster skimming components

## Plasterboard accessories



### Gyproc Paper Joint Tape

A paper tape designed for reinforcement of flat joints or internal angles.

## Finishing products



### ThistleBond-it

Bonding agent for smooth and/or low suction backgrounds providing an adequate key.



### Gyproc GypPrime

Primer to reduce suction on very dry backgrounds.

## Essential Finish Coat



### Gyproc Skimcoat

To provide a plaster skim finish on most common backgrounds including undercoat plasters and plasterboard. Can provide enhanced acoustic performance.



### Gyproc Carlite Finish

To provide a plaster skim finish on most common backgrounds including undercoat plasters and plasterboard. Can provide enhanced acoustic performance.



### Gyproc Carlite Ultra Finish

Offers all the benefits of Gyproc Skimcoat and Gyproc Carlite Finish with a reduced set time of 90-120mins, making it ideal for smaller jobs.

## Specialist Finish Coat



### Gyproc Magnetic Plaster

To provide a plaster skim finish that provides an attraction to magnets used to finish a wide range of backgrounds, including undercoat plasters and plasterboard.

## Plaster skimming installation overview

This is intended to be a basic description of how skimming is applied.



Gyproc plasters should be mixed by adding to clean water and using clean mixing equipment. Contamination from previous mixes must be avoided as this can adversely affect the setting time and strength.



Angle Bead is fixed to the plasterboard angle by embedding in the finish plaster.



Where there is an increased risk of cracking, or where joints exceed 3mm, the joints are reinforced with Gyproc Paper Joint Tape\* bedded in Gyproc plaster.



Gyproc plaster is applied with firm pressure, built out to the required thickness in two applications and trowelled to a smooth matt finish. Good site practice should be followed, as outlined in *BS EN13914 - 2: Design Considerations and Essential Principles for Internal Plastering*.



### Additional information

For full installation details, refer to the [Gyproc Installation Guide](#), available to download from [gyproc.ie](http://gyproc.ie)

\* While the tape and jointing process using Gyproc Paper Joint Tape bedded into an appropriate Gyproc jointing filler remains our best practice recommendation and offers a higher quality and stronger joint, *Gyproc systems may also achieve their stated fire, sound insulation and duty performance claims using a full surface treatment of 2mm Gyproc finishing plasters, applied as per Gyproc's current recommendations, over scrim taped joints; in lieu of the tape and jointing process using Gyproc Paper Joint Tape bedded into an appropriate Gyproc jointing filler.*

## Jointing

Gyproc jointing materials produce durable joint reinforcement and a smooth, continuous, crack-resistant surface ready for priming and final decoration



# Joining

Gyproc jointing materials seal the lining, a prerequisite if the building element is to achieve specified levels of fire resistance and sound insulation. The materials can be applied either manually using hand tools, or mechanically, using mechanical jointing tools.

A number of jointing specifications are available to suit the board type, method of application, and site preference.

## Key benefits

- Produces a seamless surface ready for decoration
- Choice of jointing materials to suit user preference, including ready-mixed or dry powder options
- For larger areas these products can be mechanically applied



## Jointing performance

### Preparation – key stages

- Boards should be securely fixed, with no steps between adjacent boards
- The correct fixings must be used and properly located with their heads just below the liner surface. Any protruding screw heads should be driven home using a hand screwdriver, prior to spotting and jointing
- Gaps between boards greater than 3mm should be pre-filled, prior to taping with Gyproc Paper Joint Tape\*
- Jointing materials should only be applied to backgrounds where the minimum temperature will remain at 5°C or above until dry

### Joint reinforcement

In a plasterboard system, suitable joint reinforcement is essential to minimise the risk of cracking along the joints, which could then appear through the decoration.

To achieve the objective of a smooth, continuous, crack-free surface, tapered edge plasterboard and Gyproc Paper Joint Tape\* should be used when jointing. The tapered edge boards provide a recess for the joint treatment, allowing a flat, finished surface. At board joints, where cut edges or square edge boards occur, the joint treatment is inevitably raised above the board surface and is more difficult to conceal. In this situation the secondary filling stage is omitted, and joint treatment is feathered-out into the field of the board to conceal the joint as much as possible.

Joint treatment has two essential components; the reinforcement and the jointing compound. Reinforcement is necessary where there is relative movement of adjacent boards. In practice, some movement is normal and Gyproc Paper Joint Tape is recommended for the best crack resistance.

### Jointing – Rigidur

When jointing Rigidur by hand, use Gyproc Joint Filler, Gyproc Gyp Filler or Gyproc Easi-Fill. The joints can be finished using mechanical jointing tool if desired. When jointing using the mechanical jointing tool, use Gyproc Gyp Finisher or Gyp Finisher Ultra for the best results.

Due to the nature of the joints on tapered edge Rigidur, the Gyproc Paper Joint Tape will need to be bedded down with a 50mm wide taping knife to flatten the tape back onto the joint. Take care to leave sufficient jointing material behind the tape to ensure good adhesion. The joints can then be finished using the mechanical jointing tool.

### Jointing – Gyptone boards

Gyproc Paper Joint Tape is bedded in Gyproc Joint Filler, Gyproc Gyp Filler or Gyproc Easi-Fill to all four tapered edges and bulk-filled. When set, a finish coat is applied to all joints by hand or using a mechanical jointing tool.

Care must be taken not to fill the perforations in the board and thereby impair the sound absorption performance.

### Jointing – Rigitone boards

Rigitone boards come with a pre-primed edge and do not require priming or sanding prior to installation. The joints should be filled with Rigitone ReadyMix joint filler which is specifically designed for use with Rigitone boards..

Once the material has been applied to the Rigitone boards, leave for approx. 1 hour and then scrape away the excess filler. Once dry, approx 12-24 hours later, the remaining filler can be sanded off to leave the joint flush with the surface.

To finish a joint where the room layout or design detail has required a Rigitone board to be cut, fill all holes falling on the joint using Rigitone ReadyMix Jointing Material and finish with a layer of Gyproc Joint Filler, Gyproc Gyp Filler or Gyproc Easi-Fill. Once a joint has been filled, remove the masking paper tape immediately. Lightly sand once dry.

### Jointing – Glasroc H TILEBACKER

Gyproc jointing materials are not generally recommended for use on Glasroc H TILEBACKER. However, where designs include part tiled areas in low-moisture environments and aesthetics is not part of the design, the joints can be re-inforced using Gyproc Paper Joint Tape and Gyproc Joint Filler, Gyproc Gyp Filler or Gyproc Easi-Fill.

\* While the tape and jointing process using Gyproc Paper Joint Tape bedded into an appropriate Gyproc jointing filler remains our best practice recommendation and offers a higher quality and stronger joint, *Gyproc systems may also achieve their stated fire, sound insulation and duty performance claims using a full surface treatment of 2mm Gyproc finishing plasters, applied as per Gyproc's current recommendations, over scrim taped joints; in lieu of the tape and jointing process using Gyproc Paper Joint Tape bedded into an appropriate Gyproc jointing filler.*

## Joining performance (continued)

### Decoration

#### Painting

After the jointing treatment has set and dried, and any final sanding is complete, the surface should be dusted down and Gyproc Drywall Primer applied by brush or medium-pile roller. Gyptone or Rigitone perforated boards are not suitable to receive spray applied primer. When roller applying Gyproc Drywall Primer and paint finishes, care should be taken to ensure primer or paint does not fill the perforations in the board, as this will impair acoustic performance.

The primer evens out differences in surface texture and absorption between the board and jointed areas, to create the ideal surface to receive final decoration. The early application of primer helps to prevent plasterboards from yellowing. Where vapour control is a requirement Isover Vario membranes may be used to provide vapour control behind plasterboard. Most paints and papers can be applied after Gyproc Drywall Primer has dried.

#### Wall coverings

Most paints and papers can be applied after Gyproc Drywall Primer has dried.

The use of specialist adhesives, for example with cloth backed or solid vinyl wall covering, may result in damage to the plasterboard surface during subsequent stripping. If the use of such adhesives is necessary, consideration should be given to cross-lining with lining paper before applying the wall covering. Please note that solvent-based wall covering adhesives should not be used.

As with all wall and ceiling areas, high sheen gloss finishes will highlight variations of the surface, particularly with shallow angle lighting. The use of low sheen or matt finishes minimises this risk.

For the correct specification in respect of any applied decorative material, reference should be made to the manufacturer of that material.

#### Air-drying and setting type compounds

Setting-only compounds - e.g. Gyproc Joint Filler jointing compounds used at the joint filling stage(s) are usually setting products. Hardening is not dependent upon atmospheric humidity. Fillers that only harden by setting are hand applied and have low shrinkage. When a setting-only product is applied as a thin layer it may 'dry-out' before it has properly hardened. Setting-only materials are therefore unsuitable for the finishing application, but are particularly suitable for bead fixing.

A setting material should never be applied on top of an air-drying material. Air-drying materials shrink as they dry, which may cause a joint to delaminate under such circumstances.

#### Air-drying compounds – e.g. Gyproc ProMix Finish, Gyproc Gyp Finisher and Gyp Finisher Ultra

Jointing compounds used for the finishing application are applied more thinly than bulk-fillers and so must have air-drying characteristics in order to harden sufficiently at feathered edges. Air-drying materials can be applied by hand or machine using mechanical jointing tools. Air-drying materials may also be used as fillers, but greater time needs to be allowed to permit the material to dry in depth, particularly in cold or humid conditions.

#### Hand versus mechanical application

Hand application provides a versatile option ideal for smaller areas or where the jointing programme cannot be completed in a single operation. Mechanical jointing tools provide consistent high speed jointing, which is cost effective where large runs of lining are involved. Mechanical jointing is available in full or part sets. The full set, for use with an air-drying product, includes tools that automatically bed tape and apply jointing compound at the same time.

Part sets include easy clean finishing boxes that can be used with Gyproc Joint Filler, Gyproc Gyp Filler or Gyproc Easi-Fill:

- Ideal for moderate to large areas of drylining
- Ideal where a number of areas can be finished in sequence
- Increased productivity
- Consistent high standards of finish
- Easy to use

#### Repairs to plasterboard

► Refer to the current **Gyproc Installation Guide**, available to download from [gyproc.ie](http://gyproc.ie)

**Table 1 – Gyproc Drywall Primer**

Product	Pack size	Typical coverage
Gyproc Drywall Primer	10 litre tubs	5m <sup>2</sup> per litre for a 10L tub (1 coat)

# Jointing components

## Plasterboard accessories



### Gyproc Joint Filler

A gypsum based setting material for bulk and secondary filling of plasterboard joints designed to be used in conjunction with Gyproc ProMix for optimum finish.



### Gyproc Gyp Filler

A gypsum based setting material for bulk and secondary filling of plasterboard joints designed to be used in conjunction with Gyproc Gyp Finisher or Gyp Finisher Ultra for optimum finish.



### Gyproc Easi-Fill

A combined setting and air-drying, gypsum based material for both bulk filling and finishing of joints. High coverage rates and minimal drying shrinkage allows application in 2 coats.



### Promix Filler

A ready-mixed, air-drying, light grey joint filler specially designed for plasterboard joints and corner beads.



### Gyproc ProMix Finish

An air-drying, ready-mixed jointing compound for filling and finishing plasterboard.



### Gyproc Gyp Finisher

A ready mixed joint compound for filling and finishing plasterboard joints.



### Gyproc Gyp Finisher Ultra

A ready-mixed joint compound for filling and finishing plasterboard joints with an even smoother finisher and even lower dust produced compared to our Gyproc Gyp Finisher.



### Gyproc Paper Joint Tape

A paper tape designed for reinforcement of flat joints or internal angles.



### Gyproc Corner Tape

A paper tape bonded to two corrosion resistant steel strips.

## Finishing products



### Gyproc Drywall Primer

A general purpose plasterboard primer, providing an ideal surface for decoration with most paints and wall coverings.



### Gyproc GypPrime

Primer to reduce suction on very dry backgrounds.

## Joining installation overview

This is intended to be a basic description of how the system is built.

### Cleaning equipment

All equipment should be thoroughly cleaned before and after use. Small residual amounts of set or part-set material will accelerate the hardening of freshly mixed setting jointing compounds, and residues of compounds left in a wet state will be subject to microbial attack.



### Hand Jointing

Gyproc Paper Joint Tape\* is bedded into the appropriate Gyproc jointing compound to all board joints and internal corners.

For external corners Gyproc Corner Tapes are bedded with a Gyproc setting compound.

Two or three further applications of jointing compound are trowel applied, each feathered out beyond the previous application. An equal number of applications are made to spot screw heads. Once dried, the joint treatment is sanded as necessary to achieve a smooth surface.



Gyproc Drywall Primer is applied to the entire board surface and jointed areas, to prepare the lining for final decorative treatment.

### Machine Jointing

Mechanical jointing tools can be used as an alternative to hand jointing, to provide a fast, consistent finish using 175mm, 250mm and 300mm finishing boxes as appropriate.

Gyproc Drywall Primer is then applied to the entire board surface and jointed areas, to prepare the lining for final decorative treatment.

\* While the tape and jointing process using Gyproc Paper Joint Tape bedded into an appropriate Gyproc jointing filler remains our best practice recommendation and offers a higher quality and stronger joint, *Gyproc systems may also achieve their stated fire, sound insulation and duty performance claims using a full surface treatment of 2mm Gyproc finishing plasters, applied as per Gyproc's current recommendations, over scrim taped joints; in lieu of the tape and jointing process using Gyproc Paper Joint Tape bedded into an appropriate Gyproc jointing filler.*



### Additional information

For full installation details, refer to the **Gyproc Installation Guide**, available to download from [gyproc.ie](http://gyproc.ie)

## Tiling

In rooms subject to high or intermittent moisture conditions, the range of boards available for tiling offers flexibility of design and peace of mind when installed in both wall linings, lightweight partition system and floor systems



# Tiling

Specifically designed for direct tiling applications, Glasroc H TILEBACKER is the ideal substrate for tiling in environments subjected to moisture, providing protection for shower enclosures, bathrooms, swimming pool changing halls and adjacent areas.

For wall areas where intermittent moisture conditions are more common, including kitchens and bathrooms, Gyproc moisture resistant grade boards are suitable.

## Key benefits

- Glasroc H TILEBACKER has been designed for use in high moisture applications
- Glasroc H TILEBACKER will hold tiling systems up to 32kg/m<sup>2</sup> on walls and 50kg/m<sup>2</sup> on floors
- Gyproc moisture resistant grade boards are suitable for use in walls in intermittent moisture conditions



## You may also be interested in...

If you require acoustic insulation or fire resistance performance, GypWall partition systems, incorporating Glasroc H TILEBACKER are available.

► Refer to C04. S02. P125 – GypWall

## Tiling performance

Table 1 – Tiling on partition systems

Partition system	Board type (including MR variants)	Stud centres mm	Additional support / comments
GypWall partitions including GypWall, GypWall <b>ROBUST</b> , GypWall <b>EXTREME</b> , GypWall <b>QUIET</b> , GypWall <b>QUIET IWL</b> and GypWall <b>AUDIO</b>	1 x 12.5mm Glasroc H <b>TILEBACKER</b> each side	600	-
	Inner layer 1 x 12.5mm Gyproc plasterboard and outer layer 1 x 12.5 Glasroc H <b>TILEBACKER</b> each side	600	-
	1 x 15mm Gyproc plasterboard (or Rigidur where appropriate) each side or 2 x 12.5mm (minimum) Gyproc plasterboard each side (including outer layer Rigidur where appropriate)	400	If using Gypframe 146mm studs, they can be located at 600mm centres to full partition height with extra studs to give 300mm centres up to tiling height
GypWall <b>QUIET SF</b>	Tiles over double layer lining board fixed on Gypframe RB1 Resilient Bar side	600 <sup>1</sup>	Horizontal Gypframe RB1 Resilient Bar at 400mm vertical centres
	Tiles over double layer lining board fixed to studs (non Gypframe RB1 Resilient Bar side)	400 <sup>1</sup>	-
GypWall <b>STAGGERED</b>	1 x 15mm Gyproc SoundBloc each side 2 x 12.5mm (minimum) Gyproc SoundBloc each side	400	-
Timber stud partitions and separating walls	12.5mm Gyproc plasterboard each side (single or double layer)	400	Timber noggings 50 x 38mm minimum at 600mm vertical centres
	15mm Gyproc plasterboard each side (single or double layer)	600	Timber noggings 50 x 38mm minimum at 600mm vertical centres
ShaftWall	1 x 15mm Gyproc FireLine	300	-
	2 x 12.5mm (minimum) Gyproc FireLine	600	Gyproc Sealant applied in a full height continuous vertical bead midway between studs
FireWall	2 x 15mm Gyproc plasterboard <sup>2</sup>	400	-

<sup>1</sup> If the tiling side is unknown, or tiling is to both sides, the studs should be at 400mm centres and the horizontal Gypframe RB1 Resilient Bars at 400mm vertical centres.

<sup>2</sup> FireWall specifications incorporating outer layer 6mm Glasroc F **MULTIBOARD** are suitable for tiling.

**NB** An outer layer of Glasroc H **TILEBACKER** 12.5mm can be added if appropriate to the system.

**NB** Reducing the centres of the metal studs within GypWall partition systems can have a detrimental effect on the sound insulation performance of the system. Refer to C02. S01. P39 – Robustness.

**NB** The recommendations given are based on experience and laboratory / site testing. In practice, performance will be dependent on factors such as workmanship and site conditions.

## Tiling performance (continued)

**Table 2 – Tiling on wall lining systems**

Wall lining system	Board type (including MR variants)	Support centres mm	Additional support / comments
DriLyner <sup>2</sup> Dabs of Gyproc Plasterboard Compound in rows	12.5mm Glasroc H TILEBACKER	600	Horizontal dabs of Gyproc Plasterboard Compound at mid-storey height Nine Gyproc Nailable Plugs through each board in the area to be tiled <sup>1</sup>
	9.5mm Gyproc WallBoard (1200mm wide)	400	For 9.5mm Gyproc WallBoard (900mm wide) support centres can be at 450mm Horizontal dabs of Gyproc Plasterboard Compound at mid-storey height
	12.5mm or 15mm Gyproc plasterboard	600	Horizontal dabs of Gyproc Plasterboard Compound at mid-storey height Nine Gyproc Nailable Plugs through each board in the area to be tiled
Gyplyner	12.5mm Glasroc H TILEBACKER 12.5mm or 15mm Gyproc plasterboard (single or double layer)	400	Fixing brackets at 600mm vertical centres
Gyplyner iwl	12.5mm Glasroc H TILEBACKER 12.5mm or 15mm Gyproc plasterboard (single or double layer)	400	Mid-height support from background structure to framework for single layer specifications
Timber battens	12.5mm Glasroc H TILEBACKER 12.5mm or 15mm Gyproc plasterboard (single or double layer)	400	Horizontal battens at head, base and intermediate positions not exceeding 1200mm centres

<sup>1</sup> 900mm x 1200mm Glasroc H TILEBACKER boards require three Gyproc Nailable Plugs per board.

<sup>2</sup> These lining systems should be left to stand for seven days before tiling begins.

**NB** The recommendations given are based on experience and laboratory / site testing. In practice, performance will be dependent on factors such as workmanship and site conditions.

# Tiling design

## Choosing tiling boards

When designing wall linings and lightweight partition systems, the following guidance details the appropriate board, application and details to use.

**Table 3 – Board lining requirements**

Level of moisture	Typical wall application	Board
<b>Low</b>	<b>Residential</b> Splash backs Kitchens Toilets	Gyproc Moisture Resistant, MR variants, Glasroc F MULTIBOARD and Rigidur
<b>Medium</b>	<b>Residential</b> Bathrooms	Gyproc Moisture Resistant and MR variants, Glasroc H TILEBACKER, Glasroc F MULTIBOARD and Rigidur
<b>High</b>	<b>Residential</b> Shower enclosure walls	Glasroc H TILEBACKER
	<b>Commercial</b> Kitchens Changing rooms	Glasroc H TILEBACKER
<b>Extreme</b>	<b>Commercial</b> Communal shower walls	Glasroc H TILEBACKER <sup>1</sup>

<sup>1</sup> In extreme moisture environments, the exposed surfaces of Glasroc H TILEBACKER should be treated with a suitable tanking system.

## Guidance for high to extreme moisture environments

### Planning - key factors

Glasroc H TILEBACKER is recommended for use as a tile backing substrate in environments subjected to moisture. The board can be used on both wall linings, lightweight partition systems and existing timber floors. Glasroc H TILEBACKER is not a structural grade flooring board and cannot be used as a walking surface.

Where the board is installed using the **Drilyner** systems, ensure the Gyproc Plasterboard Compound has set seven days before tiles are applied to the board surface. The tolerance on the finished tile surface quoted in *BS 5385: Part 1*, i.e. 3mm under a 2m straight edge with thin-bed adhesives, is such that it will reflect very accurately the standard of the background surface.

### Moisture resistance

Glasroc H TILEBACKER should not be exposed to running water. Care should be taken not to over tighten screws when fixing boards and all screw heads should be fully filled with adhesive.

In areas of high and extreme moisture and humidity, extra care should be given to detailing at junctions, perimeter sealing and tiling.

### Perimeter and junction sealing

Designers must give consideration to the precautions necessary at junctions to ensure that moisture is not allowed to penetrate or collect. Cut edges of boards must be appropriately sealed and waterproofed at abutments.

Waterproof sealant should be used around baths or shower trays, between the wall surface and the floor at the base of partition or wall lining, to prevent any possible moisture being absorbed by the board core.

### Tanking systems

In extreme moisture environments, the exposed surfaces of Glasroc H TILEBACKER should be treated with a suitable tanking system.

### Continuity of linings

All partitions and wall linings should be complete. There should be no omissions to board linings, e.g. behind baths.

## Tiling design (continued)

### Tiling

Before tiling commences, fully fill all edge joints included in the tiling area with tile adhesive. Install tiles following the manufacturer's guidance, using a waterproof tile adhesive. Tiles can be applied directly to the pre-primed surface of Glasroc H TILEBACKER, ensuring the board is dust free prior to tiling. Ensure tiles are sealed using a waterproof grout and sealant at perimeters.

### Timber stud external walls or partitions

Where tiling is specified, designers should ensure that the timber is of sufficient dimensions to give a stable base for the additional loading.

The moisture resistance of the timber should be within the limits given in *BS 5268: Structural use of timber - Part 2*.

### Underfloor heating systems

Glasroc H TILEBACKER is suitable for use in conjunction with electric underfloor heating systems. Glasroc H TILEBACKER is installed as per standard installation, electric underfloor heating systems should be installed in accordance with manufacturers installation details. The operating temperature of the heating system should not exceed 40°C.

## Guidance for low to medium moisture environments

### Planning – key factors

Glasroc H TILEBACKER, Gyproc moisture resistant grade boards, Glasroc F MULTIBOARD or Rigidur are recommended for intermittent moisture applications, including splashbacks. The tolerance on the finished tile surface quoted in *BS 5385: Part 1*, i.e. 3mm under a 2m straight edge with thin-bed adhesives, is such that it will reflect very accurately the standard of the background surface.

### Perimeter and junction sealing

Designers must give consideration to the precautions necessary at junctions to ensure that moisture is not allowed to penetrate or collect. Cut edges of boards must be appropriately sealed / waterproofed at abutments.

Waterproof sealant should be used around baths or shower trays, between the wall surface and the floor at the base of partition or wall lining, to prevent any possible moisture being absorbed by the board core.

Once boards are installed, the perimeter of the wall, e.g. base, head and wall abutments, should be sealed with a waterproof sealant.

### Continuity of linings

All partitions and wall linings should be complete. There should be no omissions to board linings, e.g. behind baths.

### Timber stud external walls or partitions

Where tiling is specified, designers should ensure that the timber is of sufficient dimensions to give a stable base for the additional loading. The moisture resistance of the timber should be within the limits given in *BS 5268: Structural use of timber - Part 2*.

### Tiling directly onto plasterboard

Before tiling commences, joints and taper recesses included within the tiling area should be filled with tile adhesive.

Only boards that are dimensionally stable in changing moisture conditions, such as MR grade and Glasroc H TILEBACKER boards should be used when tiling onto surfaces that will be subject to occasional wetting (e.g. domestic sinks and baths).

When tiling onto surfaces in high moisture areas (but are not immersed in water) e.g. communal changing rooms and shower areas, Glasroc H TILEBACKER should be used.

Where designs include part-tiled areas, e.g. low moisture environments, apply a layer of ThistleBond-it when using moisture resistant variant boards prior to the board being plaster skimmed above the line of the tiles.

## Tiling design (continued)

### Glasroc H TILEBACKER on existing timber floors

Glasroc H TILEBACKER is designed as a tiling substrate for use on an existing timber floor, it is not suitable as a walking surface and is not a structural flooring grade board. On existing timber floors ensure the floor is structurally sound and is not subject to excessive movement or flexing as this could cause a tiled floor to crack. Place a bed of tile adhesive directly onto the floor surface. Bed the board into the tile adhesive to create a level surface. Make sure the yellow pre-primed finish faces outwards for tiling. Boards are fixed through to timber sub floor using Gyproc Drywall Screws at 200mm centres. The length of fixing used should be selected to avoid penetrating through the floor surface into the cavity to prevent damage to any services that may be within the floor cavity.



# Tiling components

## Board products



### Glasroc H TILEBACKER

Non-combustible glass-reinforced gypsum board with a water resistant pre-primed acrylic coating to receive tiling.



### Glasroc F MULTIBOARD

Non-combustible glass-reinforced gypsum board.



### Gyproc FireLine MR

Plasterboard with additional additives to increase fire and moisture performance.



### Rigidur

Gypsum fibre board with additives for rigidity, durability and mechanical strength.



### Gyproc Moisture Resistant

Gypsum plasterboard with moisture resistant additives in the core.



### Gyproc DuraLine MR

Gypsum plasterboard with fire and moisture resistant additives and a high density core for enhanced sound insulation and impact resistance performance.



### Gyproc SoundBloc MR

Gypsum plasterboard with moisture resistant additives and a high density core for enhanced sound insulation performance.



### Glasroc F FIRECASE

High performance, non-combustible glass reinforced plasterboard giving up to 120 minutes fire protection.

## Fixing products



### Nailable Plugs

Secondary mechanical fixing for increased stability when tiling.

## Plasterboard accessories

**Waterproof tile adhesive** (by others)

**Tiles** (by others)

Available in: 32kg/m<sup>2</sup> (maximum including adhesive and grout)

**Waterproof sealant** (by others)



## Additional information

For full installation details, refer to the **Gyproc Installation Guide**, available to download from [gyproc.ie](http://gyproc.ie)

## Decorative effects

A wide variety of decorative effects can be achieved quickly and simply using Gyproc accessories



## Decorative effects

Gyproc decorative accessories are used to enhance walls and ceilings, and to relieve flat runs of lining, joints and angles.

### Key benefits

- Cove and Cornice profiles can be used Gyproc Cornice Strips to enhance wall and ceiling angles
- Easy installation
- Cost effective solution where coving is desirable
- An interesting and imaginative aesthetic appearance, creating shadow gaps and recessed skirtings, can be created through the use of Gyproc Styletrims
- Gyproc Cove and Gyproc Cornice can assist in improving airtightness



## Decorative effects performance

### Sound insulation

Airtightness is essential for optimum sound insulation of plasterboard building elements. Gyproc Cove and Cornice can assist in ensuring that linings meet their stated sound performance levels, since joints will be rendered impermeate during the bonding and jointing / making good process.

## Decorative effects design

### Backgrounds

Gyproc Cove and Cornice can be installed to clean, dry and sound backgrounds using Gyproc Cove Adhesive. Where the wall or ceiling has severe irregularities, the profiles can be mechanically fixed using non-rusting screws into plugs. Gaps along the wall or ceiling edge of the profile can be filled with Gyproc Cove Adhesive.

## Decorative effects components

### Fixing products



#### Gyproc Drywall Screws

Corrosion resistant self-tapping steel screws for fixing board-to-timber and board-to-metal framing less than 0.8mm thick.



#### Gyproc Collated Drywall Screws

Corrosion resistant self-tapping steel screws for fixing board-to-timber and board-to-metal framing less than 0.8mm thick.

### Decorative products



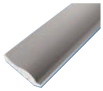
#### Gyproc Cove

Gypsum plasterboard moulding in traditional 'C' profile.



#### Gyproc Cove Adhesive

Gypsum based adhesive for fixing Gyproc Cove and Cornice.



#### Gyproc Cornice

Gypsum plasterboard moulding in classic 'S' profile.

### Plasterboard accessories



#### Gyproc Paper Joint Tape

A paper tape designed for reinforcement of flat joints or internal angles.



#### Gyproc Corner Tape

A paper tape bonded to two corrosion resistant steel strips.



#### Gyproc Sealant

Alternative method for pre-fixing Gyproc Styletrims.

### Finishing products



#### Gyproc Drywall Primer

A general purpose plasterboard primer, providing an ideal surface for decoration with most paints and wall coverings.

## Decorative effects installation overview

This is intended to be a basic description of how the system is built.  
For detailed installation guidance refer to the [Gyproc Installation Guide](#).



### Cove and Cornice

Profiles are cut to length using a fine-tooth saw and mitred using a suitable mitre block. Gyproc Cove Adhesive is evenly applied to both surfaces that will be in contact with the wall and ceiling.

Nails are lightly applied to provide temporary support to the profile until the adhesive has set. Once set, temporary nails are removed and any excess adhesive is used to make good the mitres and any joints. After installation, surfaces are treated with Gyproc Drywall Primer prior to applying the decorative paint finish.



### Additional information

For full installation details, refer to the [Gyproc Installation Guide](#), available to download from [gyproc.ie](http://gyproc.ie)

# C09

## Glossary and index

# Glossary

## Angle bead

A metal or plastic angle used to reinforce external corners.

## Backing coat

Undercoat plaster used as part of a two-coat plaster system, e.g. Gyproc Hard Coat.

## Bonding agent

Liquid preparation applied to the wall or ceiling surface prior to plastering to provide adhesion to challenging backgrounds, e.g. ThistleBond-it.

## Caulk

A joint sealing material, applied in a plastic state.

## Closing-in

The operation of consolidating the surface of a final coat plaster with a finishing trowel.

## Control joint

A joint which accepts movement in the form of lateral expansion or contraction. Allows relatively small movements to occur without damage to the internal surface e.g. Gyproc Control Joint.

## Core board

A version of fire-resistant and moisture resistant plasterboard with square edges and green coloured paper liners supplied in 19mm thickness. Used as an inside stud (core) board in shaft wall systems, e.g. Gyproc CoreBoard.

## Cove

A concave decorative moulding used at the wall to ceiling angle.

## Cut end

End of a gypsum board showing the exposed core.

## Decibel (dB)

A unit of magnitude for sound pressure, sound intensity, sound power and, in relation to sound insulation, the measurement of level reduction. Impact sound insulation, dB, is a measure of sound level.

## Deflection head

A special design feature at the head of a partition, which allows its integrity to be maintained while allowing movement such as floor slab or beam deflection to take place.

## Dew point

The temperature at which air becomes saturated with water vapour and below which condensation occurs.

## Door set

A complete unit consisting of a door frame and door leaf or leaves, supplied with essential hardware as a product from a single source.

## DPC

A damp-proof course (often abbreviated to DPC) providing a horizontal barrier in a wall designed to prevent moisture rising through the structure by capillary action.

## Dry construction

A general term describing wall linings, ceiling linings, lightweight partitions and separating walls in board or sheet materials, either self-finished, plastered or jointed as distinct from construction with solid plaster finishes.

## Drying shrinkage

Shrinkage caused by the evaporation of water.

## Drylining

Creating a wall or ceiling lining using plasterboard as an internal finish instead of solid plaster treatment.

## Drywall partition

Lightweight non-loadbearing construction, either self-finished, skimmed or jointed as distinct from masonry construction with solid plaster finishes.

## Drywall

A partition, separating wall or wall lining which uses plasterboard as a lining instead of solid plastering (can be skim plastered however).

## DSG

Desulphurised gypsum. A synthetic gypsum produced as a by-product of the desulphurisation process at coal-fired power stations.

## Edge profile of plasterboard

The bound edge of a plasterboard which is commonly square or tapered.

## Edge bead

A metal or plastic strip to protect the edges of plasterboard or to form a feature.

## Efflorescence

Formation of crystals on a surface during drying, caused by the presence of soluble salts.

## Expansion joint

A permanent joint between different parts of the structure to allow relatively small movements to occur without damage to the surface.

## Face

The side of the plasterboard from which the covering paper is carried round the edges, e.g. the exposed side for direct decoration or plastering.

## Glossary (continued)

### Feather-edge rule

Used for working angles or for closing-in an undercoat plaster after using a floating rule. It is made of wood or metal with one edge bevelled to a thickness of about 3mm.

### Final set

The point at which the plaster mix permits no movement under the trowel.

### Field of board

The face of plasterboard excluding the perimeter.

### Finishing coat

The final coat in two or three-coat plasterwork, e.g. Gyproc Skimcoat, Gyproc Carlite Finish or Gyproc Carlite Ultra Finish.

### Finishing compound

Jointing material applied over the bedding compound in one or more applications and which forms the final finished surface.

### Fire door

A door that provides fire resistance.

### Fire-resistant and moisture resistant plasterboard

A fire-resistant plasterboard with water repellent and other additives in the core, e.g. Gyproc FireLine MR.

### Fire-resistant plasterboard

A gypsum plasterboard with greater fire protection properties than standard plasterboard, e.g. Gyproc FireLine.

### Fixed partition

A partition that cannot be demounted without destroying, partially or totally, the integrity of the components.

### Flanking sound

The structure-borne transmission of sound between adjacent rooms or spaces, which bypasses the obvious dividing barriers.

### Float

Tool used in plasterwork to smooth and level the plaster surface.

### Floating coat

The undercoat immediately preceding the final coat.

### Floating floor

Part of a composite floor construction whereby the upper surface membrane (possibly a concrete screed or timber deck) is independently isolated (floated) from the lower structural floor by the use of a resilient underlay, an array of flexible pads, spring isolators or battens.

### Framed partition

A partition consisting of a continuously supported frame with facings or infillings. It may take the form of a stud and sheet, frame and sheet or frame and panel partition, e.g. Gyproc Wall.

### Furring

Timber or metal channels used to even-up a surface - on a wall for example, to provide a true surface to which plasterboards can be fixed, e.g. Gyproc MF10 Channel.

### Glass mineral wool

Mineral wool manufactured from glass used for improved thermal or acoustic performance, e.g. Isover products.

### GRG board

A gypsum board having a glass fibre reinforced core and continuous glass fibre membranes just below each surface, e.g. Glasroc F FIRECASE and Glasroc F MULTIBOARD.

### Gypsum

Calcium sulphate dihydrate ( $\text{CaSO}_4 \cdot 2\text{H}_2\text{O}$ ). A natural mineral deposit and the main raw material from which gypsum products are made.

### Gypsum adhesive

A gypsum-based compound that, when mixed with water, provides an adhesive for use in drylining systems, e.g. Gyproc Plasterboard Compound.

### Gypsum fibre board

A building board, complying with *BS EN 15283-2: 2008*, composed of gypsum, reinforced with fibres, e.g. Rigidur.

### Gypsum plank

Gypsum plasterboard 19mm thick and 600mm wide, e.g. Gyproc Plank.

### Gypsum plasterboard

A building board, complying with *EN 520*, composed of a core of aerated gypsum plaster bonded between two sheets of strong paper, e.g. Gyproc WallBoard.

### Hacking

The roughening of solid backgrounds by hand or mechanical means to provide a suitable key.

### Hairline crack

Crack just visible to the naked eye.

### Impact resistant plasterboard

A gypsum plasterboard with a heavier duty face paper, a higher density core than standard plasterboard, and additives in the core to improve impact performance, e.g. Gyproc DuraLine.

### Impact sound

Sound produced when short duration sources, e.g. footsteps and door slams, impact directly onto a structure.

### Independent wall lining

A lining (often using related partition components), which is erected independently of the external walling, e.g. Gyproc Wall.

## Glossary (continued)

### Insulating drylining

Drylining using laminates composed of plasterboard and polystyrene, phenolic foam or mineral wool, e.g. Isover Calibel or Isover InLiner.

### Joint tape

Tape that is embedded in the bedding compound to reinforce the joint, e.g. Gyproc Joint Tape.

### Jointing

The process of using hand or mechanical systems for achieving a flush seamless surface on dry construction, based on tapered edge plasterboard and applicable to walls and ceilings.

### Key

The roughness of a surface that enables plaster to make a mechanical bond with it.

### Lath

Expanded metal mesh that is fixed to a surface to provide a mechanical key for plaster.

### Masonry partition

A partition of brickwork or blockwork complete with any specified surface finishes, such as a drylining or plaster.

### Metal stud partition

A partition consisting of a metal stud / channel framework and lined both sides with sheet materials, such as plasterboard. This is a form of stud and sheet partition, e.g. GypWall.

### Metal stud separating wall

A metal stud / plasterboard partition that meets the separating wall requirements of Building Regulations for multi-occupancy dwellings, e.g. GypWall QUIET.

### Moisture resistant plasterboard

A gypsum plasterboard with moisture-repellent additives in the core, which is enclosed in water-repellent green coloured paper liners, e.g. Gyproc Moisture Resistant.

### Nogging

Cross member between main members of a framed construction. Also known as a 'dwang'.

### Noise

Unwanted sound resulting in distraction and disturbance, interference with speech and stress or damage to hearing.

### Panel

Decorative or functional portion of the cladding of a floor, ceiling, roof or wall supported by a concealed or exposed frame.

### Partition

A non-loadbearing vertical construction dividing space, e.g. GypWall.

### Pattern staining

Surface staining that sometimes occurs when the two sides of a composite structure are consistently exposed to different temperatures.

### Perforated ceiling

A ceiling incorporating tile or board products available in various edge profiles and with circular, square or rectangular perforations in random or regular pattern designs, typically used in suspended ceilings to provide sound absorption, e.g. Gyptone.

### Performance partitions

Partitions that have enhanced sound insulation, fire resistance, impact resistance, or a combination of these, e.g. GypWall ROBUST or GypWall QUIET.

### Perlite

A lightweight aggregate produced from siliceous volcanic glass, expanded by heat. Used as an additive in some backing coat plasters.

### Plaster key

Portion of the plaster that is pressed through metal lath and, when set, holds the plaster layer in place. Also applies to the mechanical key produced by scratching a plaster undercoat.

### Plenum

An enclosed chamber, e.g. space between a suspended ceiling and the floor above.

### Pricking-up

The application of the first coat of plaster on metal lathing.

### Racking resistance

A measure of a structure's ability to resist horizontal forces, such as wind loading.

### Rendering coat

First coat of plaster on a wall.

### Reverberation

The persistence of sound in an enclosure, due to its continued reflection or scattering from surfaces or objects, after the sound source has ceased.

### Sarking board

Sheet material fixed to roof framework to contribute to weather protection, which may provide a degree of racking resistance.

### Sealant

Gap filling material and adhesive, applied in a plastic state, e.g. Gyproc Sealant.

## Glossary (continued)

### Security partitions

Constructions specifically designed to be resistant to ballistic and physical attack and explosions, such as those from letter or car bombs, e.g. **GypWall SECURE** or **BlastWall**.

### Self-drilling, self-tapping

Shank and point design of a metal screw that facilitates penetration and grip into a light gauge metal section.

### Shaft wall

A partition or lining used to form fire protective enclosures to all forms of shafts, including service cores and lift shafts. It consists of multiple layers of gypsum plasterboard fixed to single or twin metal frames to give fire resistance, e.g. **ShaftWall**.

### Sheathing board

Sheet material used in framed structures. Fixed to external wall framework to contribute to weather protection, it may provide a degree of racking resistance.

### Skin

A single thickness of panelling or cladding or one leaf of a cavity wall. Single skin or double skin are used to describe a lining consisting of one or two skins of plasterboard.

### Soffit

Any semi-exposed under-surface.

### Sound absorption

Sound absorption is the loss of sound energy on interaction with a surface.

### Sound leakage

Airborne sound transmission via gaps or cracks around or through building elements and services that allow sound to escape from one area to an adjacent area, and thus lower the element's potential sound reduction properties.

### Square edge boards

Plasterboard with a square edge profile used for textured finishes or undecorated applications, as well as being suitable to receive gypsum plaster.

### Staggered metal stud partition

A partition based on a framework with alternative studs off-set within wide floor and ceiling tracks. This system is used where increased levels of sound insulation are required. Performances are higher than those achieved with a single row of stud, but lower than with twin framed partitions, e.g. **GypWall STAGGERED**.

### Stone wool

Mineral wool manufactured from stone, used to improve acoustic and fire resistance performance.

### Stud

Vertical member in framed wall or partition.

### Suction

Moisture absorption of background.

### Suspended ceiling

A ceiling formed with boards or tiles fixed into (or onto) a grid with a cavity between the suspension system and the structural soffit, joists or trusses, e.g. **CasoLine MR**.

### Suspension system

Grid of metal sections, consisting of main and cross members and hangers, to support ceiling panels.

### t&g

Tongue and groove (often abbreviated to t&g), a method of fitting similar objects together, edge to edge, is used mainly with timber constructions. Tongue and groove joints allow two sections to be joined together to create a single flat surface.

### Tapered edge

A design of a board or sheet material applicable to plasterboard particularly, and to its long bound edges to enable flush seamless jointing or plastering to be carried out in dry construction.

### Thermal laminate

A laminate consisting of gypsum plasterboard with a backing of factory bonded insulation material, providing enhanced thermal insulation. Used to provide insulated wall and soffit linings or ceilings, e.g. **Isover Calibel** or **Isover InLiner**.

### Three-coat work

Plasterwork with rendering, floating and finishing coats. Generally used when a very high quality finish is required.

### Timber stud partition

A partition consisting of a timber frame lined on each side with materials such as plasterboard.

### Undercoats

Gypsum plaster or cement render coats other than the final coat, e.g. **Gyproc Hard Coat** or **Gyproc Bonding Coat**.

### Vapour control plasterboard

A gypsum plasterboard backed with metallised polyester for wall and ceiling linings, which enables the lining and the vapour check membrane to be fixed in one operation, e.g. **Gyproc WallBoard DUPLEX**.

### Vapour control layer

A material (usually a membrane) that reduces the transfer of water vapour through a building element in which it is incorporated.

### Vermiculite

A lightweight aggregate produced from micaceous material exfoliated by heat.

### Working time

The period during which a plaster mix is workable, i.e. does not significantly stiffen.

# Index

## A

- Access Hatch C06.S02.P373
- Access panels - refer to Technical Department

## B

- Basic principles of system design - See Technical performance
- BES 6001 C02.S01.P59
- BlastWall C05.S06.P343
- Building acoustics C02.S01.P21
- Building Information Modelling (BIM) C01.S01.P12

## C

- CasoLine MF suspended ceiling C06.S02.P354
- Cavity fire barriers C06.S06.P422
- Ceiling and floor systems C06.S01.P346
- Ceiling products C06.S02.P372

## D

- Decorative effects C08.S05.P506
- Design - Technical performance C02.S01.P14
  - Building acoustics C02.S01.P21
  - Fire C02.S01.P16
  - Indoor air quality C02.S01.P62
  - Robustness C02.S01.P37
  - Service installations C02.S01.P41
  - Sustainability C02.S01.P57
  - Thermal insulation and condensation C02.S01.P49
- DriLyner Wall Linings C07.S03.P444
- Drywall Academy - See Saint-Gobain Technical Academy

## E

- Environmental Consideration C01.S01.P10

## F

- Finishes C08.S01.P483
- FireCase C03.S02.P70
- Fire System C02.S01.P16
- FireWall System C05.S03.P320
- Floors and ceilings systems C06.S01.P345

## G

- Glossary C09.S01.P512
- GypFloor SILENT system C06.S04.P390
- GypLyner ceiling system C06.S03.P376
- GypLyner ENCASE system C03.S03.P90
- GypLyner IWL system C07.S05.P468
- GypLyner wall lining system C06.S03.P376
- GypWall AUDIO system C04.S09.P244
- GypWall CURVE system C05.S04.P328
- GypWall EXTREME system C04.S04.P178
- GypWall QUIET IWL system C04.S08.P230
- GypWall QUIET SF system C04.S05.P192
- GypWall QUIET system C04.S07.P218
- GypWall ROBUST system C04.S03.P156
- GypWall SECURE system C05.S05.P338
- GypWall STAGGERED system C04.S06.P206
- GypWall SUPERIOR system C04.S10.P258
- GypWall system C04.S02.P124

## I

- Indoor air quality C02.S01.P62
- Introduction C01.S01.P01

## J

- Jointing C08.S03.P492

## L

- Laboratory testing C01.S01.P07
- Life Cycle Assessments (LCA) C01.S01.P11
- Lining systems C07.S01.P429
- Loadbearing timber joist floors C06.S05.P402

## M

- Magnetic Plaster C08.S02.P488

## N

- Non-loadbearing timber stud C04.S11.P274

## P

- Partitions and wall systems C04.S01.P105
- Plasterboard Recycling C02.S01.P61
- Plaster skimming C08.S02.P486
- Plaster systems C07.S02.P434

## Index (continued)

**R**

Responsible sourcing	C01.S01.P10
Robustness	C02.S01.P37

**S**

Saint-Gobain Technical Academy	C01.S01.P05
Service installations	C02.S01.P41
ShaftWall system	C05.S02.P290
Site testing	C01.S01.P07
Specialist partitions	C05.S01.P287
SpecSure® Gyproc Systems Guarantee	C01.S01.P08
Steel encasements	C03.S01.P65
Styletrims	C08.S05.P507
Sustainability	C02.S01.P57
Systems	
BlastWall	C05.S06.P343
Casoline MF suspended ceiling	C06.S02.P354
Cavity fire barriers	C06.S06.P422
Drilyner Wall Linings	C07.S03.P444
FireCase	C03.S02.P70
FireWall	C05.S03.P320
GypFloor SILENT	C06.S04.P390
Gyplyner ceiling system	C06.S03.P376
Gyplyner ENCASE	C03.S03.P90
Gyplyner IWL	C07.S05.P468
Gyplyner wall lining system	C07.S04.P460
GypWall	C04.S02.P124
GypWall AUDIO	C04.S09.P244
GypWall CURVE	C05.S04.P328
GypWall EXTREME	C04.S04.P178
GypWall QUIET	C04.S07.P218
GypWall QUIET IWL	C04.S08.P230
GypWall QUIET SF	C04.S05.P192
GypWall ROBUST	C04.S03.P156
GypWall SECURE	C05.S05.P338
GypWall STAGGERED	C04.S06.P206
GypWall SUPERIOR	C04.S10.P258
Loadbearing timber joist floors	C06.S05.P402
Non-loadbearing timber stud	C04.S11.P274
Plaster systems	C07.S02.P434
ShaftWall	C05.S02.P290
Timber joist - See loadbearing timber joist	

**T**

Technical Academy - refer to Saint-Gobain Technical Academy	
Technical Department	C01.S01.P04
Technical performance	C02.S01.P15
Testing	C01.S01.P07
Thermal insulation and condensation	C02.S01.P49
Tiling	C08.S04.P498
Timber joist - Loadbearing	C06.S05.P402
Timber stud - Non-loadbearing	C04.S11.P274

**W**

Wall lining systems - See Lining systems

Gyproc, Gyproframe, Glasroc and Habito are all registered trade names of Saint-Gobain Construction Products (Irl) Limited. Isover is a registered trade name of Saint-Gobain.

Saint-Gobain Construction Products (Irl) Limited trading as Gyproc Ireland, registered in Ireland, Company Number 11815, registered office at Unit 4 Kilcarbery Business Park, Nangor Road, Dublin 22, D22 R2V7, Republic of Ireland

Saint-Gobain Construction Products (Irl) Limited reserves the right to revise product specifications without notice. The information in this document was correct to the best of our knowledge at the time of publication. It is the user's responsibility to ensure that it remains current prior to use. The information in this document is for guidance only and should not be read in isolation. Users should always ensure they are fully conversant with the products and systems being used and their subsequent installation prior to the commencement of work. For a comprehensive and up-to-date library of information visit the Gyproc website at: [gyproc.ie](http://gyproc.ie)

### **Gyproc**

Unit 4  
Kilcarbery Business Park  
Nangor Road,  
Dublin 22  
Tel: 00 353 (1) 629 8400  
Email: [enquiries@gyproc.ie](mailto:enquiries@gyproc.ie)

### **Technical Support**

ROI Free Phone: 1800 744480  
NI Free Phone: 0845 3990159  
Email: [tech.ie@saint-gobain.com](mailto:tech.ie@saint-gobain.com)

**Saint-Gobain Construction Products (Irl) Limited October 2020**