

Gyplyner ENCASE

Metal framed structural steel encasement system



GypLyner ENCASE

GypLyner ENCASE is a metal framed structural steel encasement system capable of providing up to 180 minutes fire protection to structural steel columns and beams. Installation is quick and easy due to the use of simple clip fixings to secure the framing sections.



The system will protect all universal column and beam sections with flange thicknesses between 6mm and 28mm. **GypLyner ENCASE** will also protect many joist sections. It can be used in any type of building where encasement to structural steel is required.

Key benefits

- Reduced installation time due to the simple, clip-on framing system with **GypLyner ENCASE**
- Misalignment of structural steelwork can be accommodated by the versatile framing system to ensure the lining is straight and true
- Improved acoustic performance as a result of the boards being fixed into a framework rather than directly into the steel beam or column
- Damage to **GypLyner ENCASE** is more easily identifiable when compared to other fire protection systems such as intumescent paint

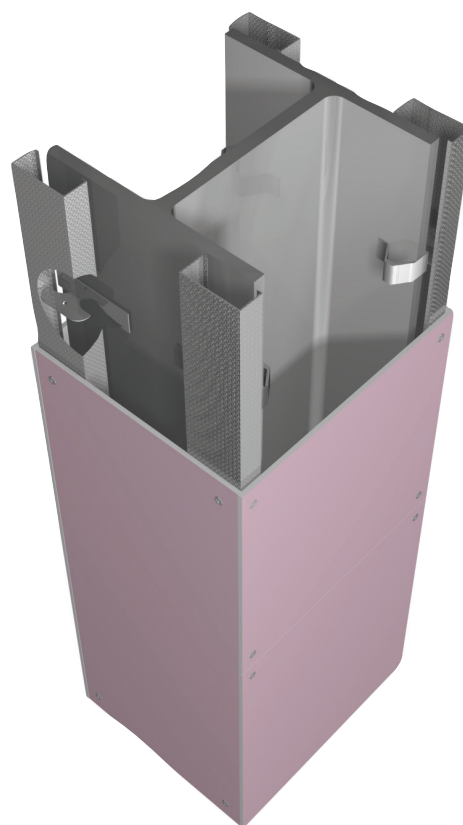

You may also be interested in...



Need to minimise the space taken by the structural steel encasement system? If so, consider the frameless FireCase system.

▶ Refer to C03, S02, P71 – FireCase

If you need to protect structural steel within the cavity.

▶ Refer to C04, S07, P219 – GypWall QUIET or C04, S08, P231 – GypWall QUIET IWL

Planning - key factors

Gyplyner ENCASE steel encasement is suitable for protecting structural steel sections with a section factor A/V (H_p/A) up to $260m^{-1}$, calculated on the basis of box protection to three or four sides as required. It will protect all universal column and beam sections described in *BS 4: Part 1*, and many joist sections.

Building Design

This system comprises Gypframe GL10 Gyplyner Steel Framing Clips located on steel sections at 800mm centres to support Gypframe GL1 Lining Channels.

Lining selection

Follow either of the procedures below to determine the thickness of cladding required:

Option 1

Use tables 2 - 4 to select steel size and fire protection then read off the required board size.

Option 2

- 1 Ascertain whether protection is required on three or four sides of the section
- 2 Find out what period of fire resistance is required
- 3 Refer to the A/V (H_p/A) tables 5 - 7. Locate the steel section to be protected, listed by its size and mass per metre, and read off the section factor A/V
- 4 Refer to tables 8 - 11. Locate the A/V value on the vertical scale on the appropriate table. Read across the chart to the column relating to the period of fire resistance required and read off the designated thickness of the relevant cladding required to form the encasement
- 5 Select the type of board to be used

For castellated sections and cellular beams please refer to the Association for Specialist Fire Protection publication, ASFP Yellow Book - 'Fire Protection for Structural Steel in Buildings' for guidance, available to download from asfp.org.uk

Size of encasement

The minimum dimension of encasement required for three or four-sided protection can be determined as shown in table 1.

Table 1 – The minimum dimension of encasements required for three or four sided protection

Depth	Calculation
Three-sided encasements	Overall steel section depth + 25mm + the thickness of lining board
Four-sided encasements	Overall steel section depth + 50mm + twice the thickness of lining board
Width	Calculation
Three and four-sided encasements	Overall steel section width + 20mm + twice the thickness of lining board



Handy hint

Where larger encasement systems are required, a 'boxing out' method using Gypframe studs and channels can be used.

- ▶ Refer to construction details 7 - 8.

Partition fixing

Partitions and wall linings can be fixed through to the metal framework.

- ▶ Refer to construction details 5 - 6.

Water vapour resistance

Vapour control can be provided to encasements which form part of an external wall lining by using Gyproc FireLine DUPLEX as the lining. Where Glasroc F FIRECASE or Glasroc F MULTIBOARD forms the lining, vapour control can be achieved by using a suitable proprietary paint treatment.

Board finishing

- ▶ Refer to C08. S01. P511 – Finishes, Plaster Skimming.



Important information

- Where the steel section web or flange dimension exceeds 600mm, additional support will be required for the cladding. Noggings of Gypframe GL1 Lining Channel are installed at 600mm centres between adjacent Gypframe GL1 Lining Channels to form supplementary framing.
- All board joints should be staggered by a minimum of 600mm.

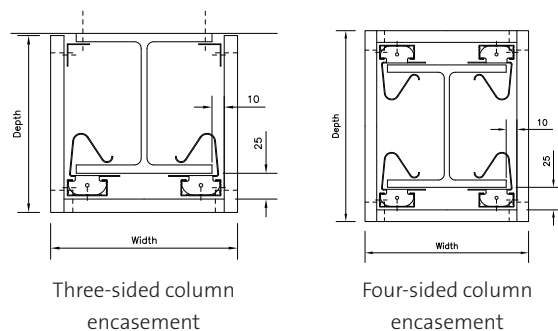



Table 2 – 550°C chart to BS 476: Part 20 for selecting the required Gyproc FireLine lining thickness for universal beam sizes

Universal beams serial size of steel (mm x mm x kg/m)			Total Gyproc FireLine board thickness (mm) to achieve fire resistance below ¹							
			3 sided encasements				4 sided encasements			
D	B	Mass/metre	30 min	60 min	90 min	120 min	30 min	60 min	90 min	120 min
1016	305	487	12.5	12.5	15	27.5	12.5	12.5	15	27.5
	305	438	12.5	12.5	15	27.5	12.5	12.5	15	27.5
	305	393	12.5	12.5	15	27.5	12.5	12.5	15	27.5
	305	349	12.5	12.5	15	27.5	12.5	12.5	15	27.5
	305	314	12.5	12.5	15	27.5	12.5	12.5	15	27.5
	305	272	12.5	12.5	15	27.5	12.5	12.5	25	27.5
	305	249	12.5	12.5	15	27.5	12.5	12.5	25	27.5
	305	222	12.5	12.5	15	27.5	12.5	12.5	25	30
914	419	388	12.5	12.5	15	27.5	12.5	12.5	15	27.5
	419	343	12.5	12.5	15	27.5	12.5	12.5	15	27.5
	305	289	12.5	12.5	15	27.5	12.5	12.5	15	27.5
	305	253	12.5	12.5	15	27.5	12.5	12.5	25	27.5
	305	224	12.5	12.5	25	27.5	12.5	12.5	25	27.5
	305	201	12.5	12.5	25	27.5	12.5	12.5	25	30
838	292	226	12.5	12.5	15	27.5	12.5	12.5	25	27.5
	292	194	12.5	12.5	25	27.5	12.5	12.5	25	30
	292	176	12.5	12.5	25	30	12.5	12.5	25	30
762	267	197	12.5	12.5	15	27.5	12.5	12.5	25	27.5
	267	173	12.5	12.5	25	27.5	12.5	12.5	25	30
	267	147	12.5	12.5	25	30	12.5	12.5	25	30
	267	134	12.5	12.5	25	30	12.5	12.5	25	30
686	254	170	12.5	12.5	25	27.5	12.5	12.5	25	30
	254	152	12.5	12.5	25	27.5	12.5	12.5	25	30
	254	140	12.5	12.5	25	30	12.5	12.5	25	30
	224	125	30	12.5	12.5	25	30	12.5	12.5	25
610	305	238	12.5	12.5	15	27.5	12.5	12.5	15	27.5
	305	179	12.5	12.5	15	27.5	12.5	12.5	25	27.5
	305	149	12.5	12.5	25	27.5	12.5	12.5	25	30
	229	140	12.5	12.5	25	27.5	12.5	12.5	25	30
	229	125	12.5	12.5	25	30	12.5	12.5	25	30
	229	113	12.5	12.5	25	30	12.5	12.5	25	30
	229	101	12.5	12.5	25	30	12.5	12.5	25	30
	178	100	12.5	12.5	25	30	12.5	12.5	25	30
	178	92	12.5	12.5	25	30	12.5	12.5	25	30
	178	82	12.5	12.5	25	30	12.5	12.5	25	30
	533	312	273	12.5	12.5	15	27.5	12.5	12.5	15
312		219	12.5	12.5	15	27.5	12.5	12.5	15	27.5
312		182	12.5	12.5	15	27.5	12.5	12.5	25	27.5
312		151	12.5	12.5	25	27.5	12.5	12.5	25	30
210		138	12.5	12.5	25	27.5	12.5	12.5	25	27.5
210		122	12.5	12.5	25	27.5	12.5	12.5	25	30
210		109	12.5	12.5	25	30	12.5	12.5	25	30
210		101	12.5	12.5	25	30	12.5	12.5	25	30
210		92	12.5	12.5	25	30	12.5	12.5	25	30
210		82	12.5	12.5	25	30	12.5	12.5	25	30
165		85	12.5	12.5	25	30	12.5	12.5	25	30
165		75	12.5	12.5	25	30	12.5	12.5	25	30
165		66	12.5	12.5	25	30	12.5	12.5	25	30

¹ Gyproc FireLine thickness combinations

- 12.5mm = 1 x 12.5mm
- 25mm = 2 x 12.5mm
- 30mm = 2 x 15mm
- 37.5mm = 3 x 12.5mm

System reference: D150001

Beam/column/joist dimension orientation:

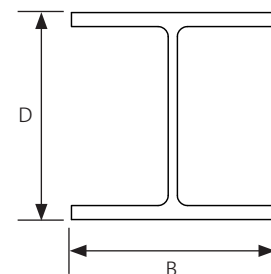



Table 2 (continued) – 550°C chart to BS 476: Part 20 for selecting the required Gyproc FireLine lining thickness for universal beam sizes

▶ Refer to C02. S01. P18

Universal beams serial size of steel (mm x mm x kg/m)			Total Gyproc FireLine board thickness (mm) to achieve fire resistance below ¹								
			3 sided encasements				4 sided encasements				
D	B	Mass/metre	30 min	60 min	90 min	120 min	30 min	60 min	90 min	120 min	
457	191	161	12.5	12.5	15	27.5	12.5	12.5	15	27.5	
	191	133	12.5	12.5	15	27.5	12.5	12.5	25	27.5	
	191	106	12.5	12.5	25	27.5	12.5	12.5	25	30	
	191	98	12.5	12.5	25	30	12.5	12.5	25	30	
	191	89	12.5	12.5	25	30	12.5	12.5	25	37.5	
	191	82	12.5	12.5	25	30	12.5	12.5	25	37.5	
	191	74	12.5	12.5	25	37.5	12.5	12.5	25	37.5	
	191	67	12.5	12.5	25	37.5	12.5	12.5	25	37.5	
	152	82	12.5	12.5	25	30	12.5	12.5	25	37.5	
	152	74	12.5	12.5	25	37.5	12.5	12.5	25	37.5	
	152	67	12.5	12.5	25	37.5	12.5	12.5	25	37.5	
	152	60	12.5	12.5	25	37.5	12.5	12.5	25	37.5	
	152	52	12.5	12.5	25	37.5	12.5	15	25	37.5	
	406	178	85	12.5	12.5	25	30	12.5	12.5	25	30
		178	74	12.5	12.5	25	30	12.5	12.5	25	37.5
178		67	12.5	12.5	25	37.5	12.5	12.5	25	37.5	
178		60	12.5	12.5	25	37.5	12.5	12.5	25	37.5	
178		54	12.5	12.5	25	37.5	12.5	15	25	37.5	
140		53	12.5	12.5	25	37.5	12.5	12.5	25	37.5	
140		46	12.5	12.5	25	37.5	12.5	15	25	37.5	
140		39	12.5	15	25	37.5	12.5	25	27.5	40	
356		171	67	12.5	12.5	25	30	12.5	12.5	25	37.5
	171	57	12.5	12.5	25	37.5	12.5	12.5	25	37.5	
	171	51	12.5	12.5	25	37.5	12.5	12.5	25	37.5	
	171	45	12.5	12.5	25	37.5	12.5	15	25	37.5	
	127	39	12.5	12.5	25	37.5	12.5	15	25	40	
	127	33	12.5	15	25	40	12.5	25	27.5	40	
305	165	54	12.5	12.5	25	37.5	12.5	12.5	25	37.5	
	165	46	12.5	12.5	25	37.5	12.5	12.5	25	37.5	
	165	40	12.5	12.5	25	37.5	12.5	15	25	37.5	
	127	48	12.5	12.5	25	37.5	12.5	12.5	25	37.5	
	127	42	12.5	12.5	25	37.5	12.5	12.5	25	37.5	
	127	37	12.5	12.5	25	37.5	12.5	15	25	37.5	
	102	33	12.5	15	25	37.5	12.5	25	25	40	
	102	28	12.5	25	25	40	12.5	25	27.5	42.5	
	102	25	12.5	25	27.5	40	12.5	25	27.5	42.5	
	254	146	43	12.5	12.5	25	37.5	12.5	12.5	25	37.5
146		37	12.5	12.5	25	37.5	12.5	15	25	37.5	
146		31	12.5	12.5	25	37.5	12.5	25	25	40	
102		28	12.5	15	25	37.5	12.5	25	25	40	
102		25	12.5	15	25	37.5	12.5	25	27.5	40	
102		22	12.5	25	27.5	40	12.5	25	27.5	42.5	
203	133	30	12.5	12.5	25	37.5	12.5	15	25	37.5	
	133	25	12.5	15	25	37.5	12.5	25	27.5	40	
	102	23	12.5	15	25	37.5	12.5	25	27.5	40	
178	102	19	12.5	15	25	37.5	12.5	25	27.5	42.5	
152	89	16	12.5	15	25	40	12.5	25	27.5	42.5	
127	76	13	12.5	25	25	40	12.5	25	27.5	42.5	

¹ Gyproc FireLine thickness combinations

- 12.5mm = 1 x 12.5mm
- 15mm = 1 x 15mm
- 25mm = 2 x 12.5mm
- 27.5mm = 1 x 15mm + 1 x 12.5mm
- 30mm = 2 x 15mm
- 37.5mm = 3 x 12.5mm
- 40mm = 1 x 15mm + 2 x 12.5mm
- 42.5mm = 2 x 15mm + 1 x 12.5mm

System reference: D150001

Beam/column/joist dimension orientation:

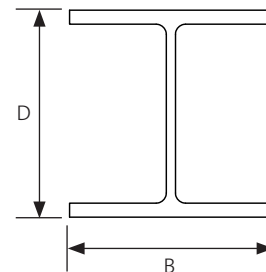



Table 3 – 550°C chart to BS 476: Part 20 for selecting the required Gyproc FireLine lining thickness for universal column sizes

Universal columns serial size of steel (mm x mm x kg/m)			Total Gyproc FireLine board thickness (mm) to achieve fire resistance below ¹							
D	B	Mass/metre	3 sided encasements				4 sided encasements			
			30 min	60 min	90 min	120 min	30 min	60 min	90 min	120 min
356	406	634	12.5	12.5	15	27.5	12.5	12.5	15	27.5
	406	551	12.5	12.5	15	27.5	12.5	12.5	15	27.5
	406	467	12.5	12.5	15	27.5	12.5	12.5	15	27.5
	406	393	12.5	12.5	15	27.5	12.5	12.5	15	27.5
	406	340	12.5	12.5	15	27.5	12.5	12.5	15	27.5
	406	287	12.5	12.5	15	27.5	12.5	12.5	15	27.5
	406	235	12.5	12.5	15	27.5	12.5	12.5	15	27.5
	368	202	12.5	12.5	15	27.5	12.5	12.5	15	27.5
	368	177	12.5	12.5	15	27.5	12.5	12.5	15	27.5
	368	153	12.5	12.5	15	27.5	12.5	12.5	25	27.5
	368	129	12.5	12.5	15	27.5	12.5	12.5	25	30
	305	305	283	12.5	12.5	15	27.5	12.5	12.5	15
305		240	12.5	12.5	15	27.5	12.5	12.5	15	27.5
305		198	12.5	12.5	15	27.5	12.5	12.5	15	27.5
305		158	12.5	12.5	15	27.5	12.5	12.5	15	27.5
305		137	12.5	12.5	15	27.5	12.5	12.5	15	27.5
305		118	12.5	12.5	15	27.5	12.5	12.5	25	27.5
305		97	12.5	12.5	25	27.5	12.5	12.5	25	30
254	254	167	12.5	12.5	15	27.5	12.5	12.5	15	27.5
	254	132	12.5	12.5	15	27.5	12.5	12.5	15	27.5
	254	107	12.5	12.5	15	27.5	12.5	12.5	25	27.5
	254	89	12.5	12.5	15	27.5	12.5	12.5	25	30
	254	73	12.5	12.5	25	27.5	12.5	12.5	25	30
203	203	127	12.5	12.5	15	27.5	12.5	12.5	15	27.5
	203	113	12.5	12.5	15	27.5	12.5	12.5	15	27.5
	203	100	12.5	12.5	15	27.5	12.5	12.5	15	27.5
	203	86	12.5	12.5	15	27.5	12.5	12.5	25	27.5
	203	71	12.5	12.5	15	27.5	12.5	12.5	25	30
	203	60	12.5	12.5	25	27.5	12.5	12.5	25	30
	203	52	12.5	12.5	25	30	12.5	12.5	25	30
	203	46	12.5	12.5	25	30	12.5	12.5	25	30
152	152	51	12.5	12.5	25	27.5	12.5	12.5	25	30
	152	44	12.5	12.5	25	27.5	12.5	12.5	25	30
	152	37	12.5	12.5	25	30	12.5	12.5	25	30
	152	30	12.5	12.5	25	30	12.5	12.5	25	30
	152	23	12.5	12.5	25	30	12.5	25	27.5	30



Table 4 – 550°C chart to BS 476: Part 20 for selecting the required Gyproc FireLine lining thickness for universal joist sizes

Universal joist serial size of steel (mm x mm x kg/m)			Total Gyproc FireLine board thickness (mm) to achieve fire resistance below ¹							
D	B	Mass/metre	3 sided encasements				4 sided encasements			
			30 min	60 min	90 min	120 min	30 min	60 min	90 min	120 min
254	203	82	12.5	12.5	15	27.5	12.5	12.5	25	30
	114	37	12.5	12.5	25	30	12.5	12.5	25	30
203	152	52	12.5	12.5	25	27.5	12.5	12.5	25	30
	102	25	12.5	12.5	25	30	12.5	15	25	30
178	102	22	12.5	12.5	25	30	12.5	25	27.5	30
152	127	37	12.5	12.5	25	30	12.5	12.5	25	30
	89	17	12.5	15	25	30	12.5	25	27.5	30
	76	18	12.5	12.5	25	30	12.5	25	25	30
127	114	30	12.5	12.5	25	30	12.5	12.5	25	30
	114	27	12.5	12.5	25	30	12.5	12.5	25	30
	76	16	12.5	12.5	25	30	12.5	15	25	30
	76	13	12.5	15	25	30	12.5	25	27.5	30
114	114	27	12.5	12.5	25	30	12.5	12.5	25	30
102	102	23	12.5	12.5	25	30	12.5	12.5	25	30
	64	10	12.5	15	27.5	30				
	44	7	12.5	25	27.5	30				
89	89	19	12.5	12.5	25	30	12.5	12.5	25	30
76	76	15	12.5	12.5	25	30	12.5	12.5	25	30
	76	13	12.5	12.5	25	30	12.5	15	25	30

¹ Gyproc FireLine thickness combinations

12.5mm = 1 x 12.5mm

15mm = 1 x 15mm

25mm = 2 x 12.5mm

27.5mm = 1 x 15mm + 1 x 12.5mm

30mm = 2 x 15mm

37.5mm = 3 x 12.5mm

40mm = 1 x 15mm + 2 x 12.5mm

42.5mm = 2 x 15mm + 1 x 12.5mm

- protection not possible

System reference: D150001

Beam/column/joist dimension orientation:

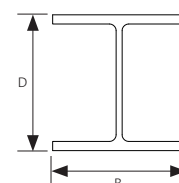

Gyplyner ENCASE design (continued)

Table 5 – Section factor A/V (Hp/A) of universal beams

Universal beams serial size of steel (mm x mm x kg/m)			A / V values		
			3 sided encasements	4 sided encasements	
D	B	Mass/metre	m ⁻¹	m ⁻¹	
1016	305	487	40	45	
	305	438	40	50	
	305	393	45	55	
	305	349	50	60	
	305	314	55	65	
	305	272	65	75	
	305	249	70	80	
	305	222	80	90	
	914	419	388	45	55
		419	343	50	60
305		289	60	65	
305		253	65	75	
305		224	75	85	
305		201	80	95	
838	292	226	70	80	
	292	194	80	90	
	292	176	90	100	
762	267	197	70	85	
	267	173	80	95	
	267	147	95	110	
	267	134	105	120	
686	254	170	75	90	
	254	152	85	95	
	254	140	90	105	
	254	125	100	115	
610	305	238	50	60	
	305	179	70	80	
	305	149	80	95	
	229	140	80	95	
	229	125	90	105	
	229	113	100	115	
	229	101	110	130	
	178	100	110	125	
	178	92	120	135	
	178	82	130	150	
	533	312	273	40	50
		312	219	50	65
		312	182	60	75
312		151	75	90	
210		138	75	85	
210		122	85	95	
210		109	95	110	
210		101	100	115	
210		92	110	125	
210		82	120	140	
165		85	115	130	
165		75	130	145	
165		66	145	165	

Table 5 (continued) – Section factor A/V (Hp/A) of universal beams

Universal beams serial size of steel (mm x mm x kg/m)			A / V values		
			3 sided encasements	4 sided encasements	
D	B	Mass/metre	m ⁻¹	m ⁻¹	
457	191	161	60	65	
	191	133	70	80	
	191	106	85	100	
	191	98	90	105	
	191	89	100	115	
	191	82	105	125	
	191	74	115	135	
	191	67	130	150	
	152	82	105	120	
	152	74	115	130	
	152	67	125	145	
	152	60	140	160	
	152	52	160	180	
	406	178	85	95	110
178		74	105	125	
178		67	115	140	
178		60	130	155	
178		54	145	170	
140		53	140	160	
140		46	160	185	
140		39	190	215	
356		171	67	105	125
		171	57	120	145
		171	51	135	160
	171	45	150	180	
	127	39	165	195	
	127	33	195	225	
	305	165	54	115	140
165		46	135	160	
165		40	150	185	
127		48	120	145	
127		42	140	160	
127		37	155	180	
102		33	175	200	
102		28	200	230	
102		25	225	255	
254		146	43	120	150
	146	37	140	170	
	146	31	165	200	
	102	28	175	200	
	102	25	190	225	
	102	22	220	255	
	203	133	30	145	180
133		25	170	210	
102		23	175	205	
178		102	19	190	230
152	89	16	195	235	
127	76	13	200	245	

Beam/column/joist dimension orientation:

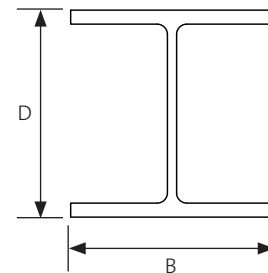

Table 6 – Section factor A/V (Hp/A) of universal columns

Universal columns serial size of steel (mm x mm x kg/m)			A / V values	
			3 sided encasements	4 sided encasements
D	B	Mass/metre	m ⁻¹	m ⁻¹
356	406	634	15	20
	406	551	20	25
	406	467	20	30
	406	393	25	35
	406	340	30	35
	406	287	30	45
	406	235	40	50
	368	202	45	60
	368	177	50	65
	368	153	55	75
	368	129	65	90
	305	305	283	30
305		240	35	45
305		198	40	50
305		158	50	65
305		137	55	70
305		118	60	85
305		97	75	100
254		254	167	40
	254	132	50	65
	254	107	60	75
	254	89	70	90
	254	73	80	110
203	203	127	45	55
	203	113	45	60
	203	100	55	70
	203	86	60	80
	203	71	70	95
	203	60	80	110
	203	52	95	125
	203	46	105	140
152	152	51	75	100
	152	44	85	115
	152	37	100	135
	152	30	120	160
	152	23	155	210

Table 7 – Section factor A/V (Hp/A) of universal joist

Universal joist serial size of steel (mm x mm x kg/m)			A / V values	
			3 sided encasements	4 sided encasements
D	B	Mass/metre	m ⁻¹	m ⁻¹
254	203	82	70	90
	114	37	130	155
203	152	52	85	105
	102	25	155	190
178	102	22	165	205
152	127	37	90	120
	89	17	180	220
127	76	18	165	200
	114	30	100	130
114	114	27	110	140
	76	16	155	195
102	76	13	195	240
	114	27	100	135
89	102	23	105	140
	64	10	215	270
76	44	7	260	305
	89	19	105	145
76	76	15	120	165
	76	13	140	185

Beam/column/joist dimension orientation:

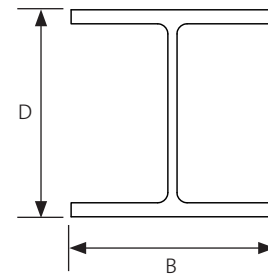

Gyplyner ENCASE performance - columns and beams



Table 8
The 550°C chart to BS 476: Part 20 for selecting Gyproc FireLine lining thickness
▶ Refer to C02. S01. P18

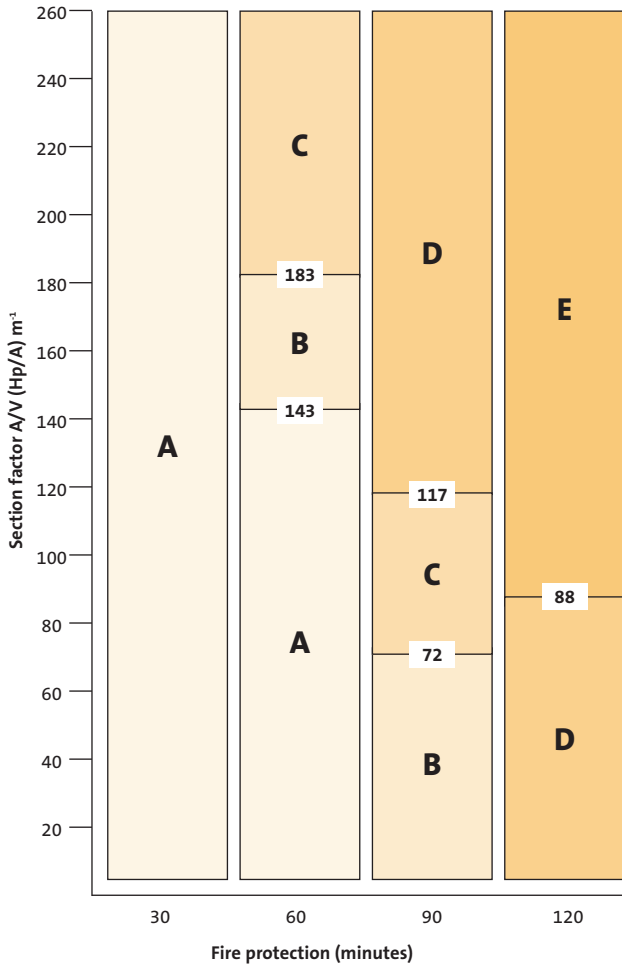

Key - Thickness of Gyproc FireLine required

- A = 12.5mm
- B = 15mm
- C = 25mm (12.5mm + 12.5mm)
- D = 30mm (15mm + 15mm)
- E = 45mm (15mm + 15mm + 15mm)

System reference: D150001



Table 9
The 550°C chart to BS 476: Part 20 for selecting Gyproc FireLine lining thickness
▶ Refer to C02. S01. P18

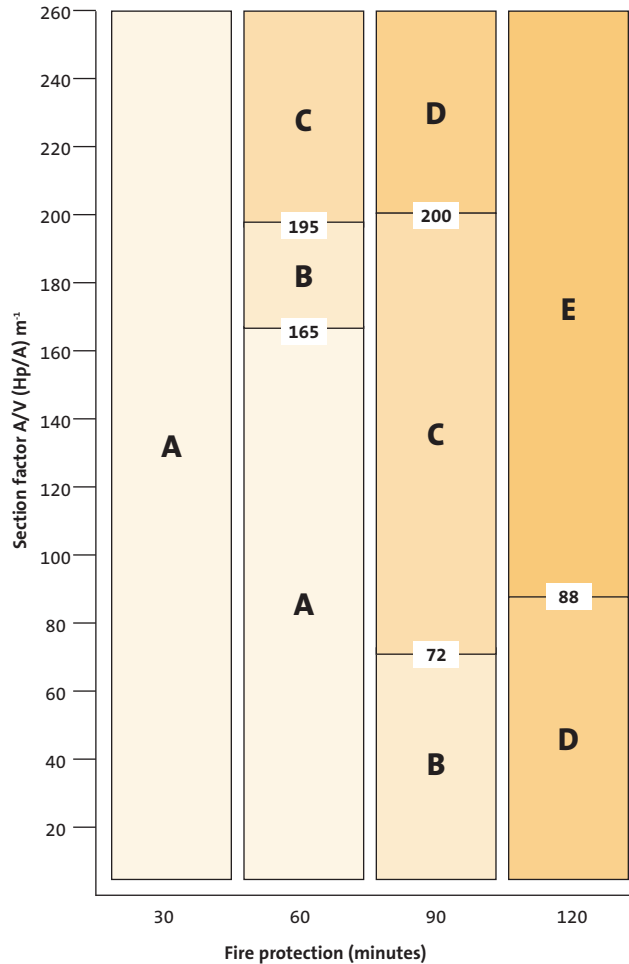

Key - Thickness of Gyproc FireLine required

- A = 12.5mm
- B = 15mm
- C = 25mm (12.5mm + 12.5mm)
- D = 27.5mm (15mm + 12.5mm)
- E = 30mm (15mm + 15mm)

System reference: D150001

NB The fire resistance performances are for imperforate linings with all joints taped and filled or skimmed. The quoted performances are achieved only if Gyproc and Saint-Gobain Isover components are used throughout, and the Company's fixing recommendations are strictly observed. Any variation in the specifications should be checked with Gyproc.



Table 10
Solutions to satisfy the 550°C criteria when tested in accordance with BS 476: Part 20: 1987 (beam and column encasement)
▶ Refer to C02. S01. P18



Table 11
Solutions to satisfy the 550°C criteria when tested in accordance with BS 476: Part 21: 1987 (column encasement) lining thickness
▶ Refer to C02. S01. P18

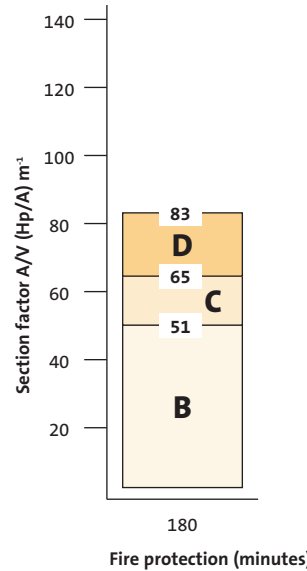
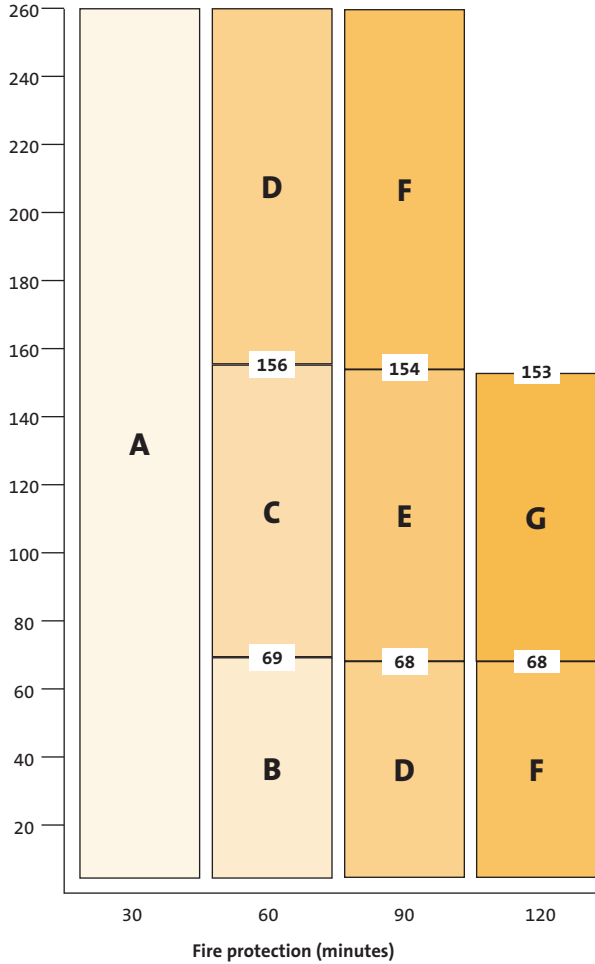

Key - Thickness of Gyproc F MULTIBOARD required

- A = 6mm
- B = 10mm
- C = 12.5mm
- D = 20mm (10mm + 10mm)
- E = 25mm (12.5mm + 12.5mm)
- F = 30mm (10mm + 10mm + 10mm)
- G = 37.5mm (12.5mm + 12.5mm + 12.5mm)

System reference: D150002

Key - Thickness of Glasroc F FIRECASE required

- B = 40mm (20mm + 20mm)
- C = 45mm (25mm + 20mm)
- D = 50mm (25mm + 25mm)

System reference: D120003

(NB) The fire resistance performances are for imperforate linings with all joints taped and filled or skimmed. The quoted performances are achieved only if Gyproc and Saint-Gobain Isover components are used throughout, and the Company's fixing recommendations are strictly observed. Any variation in the specifications should be checked with Gyproc.

Gyplyner ENCASE construction details

1

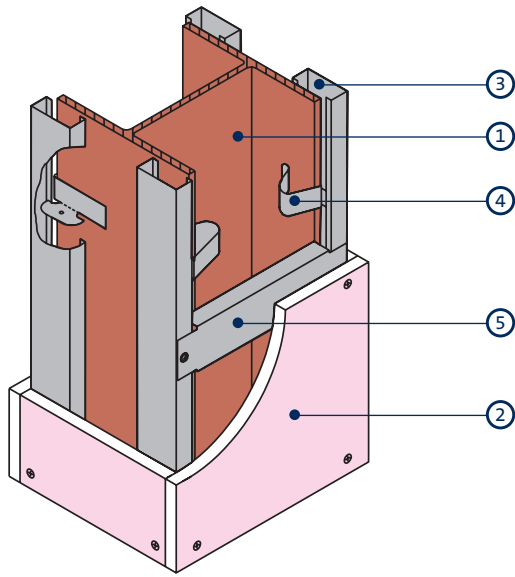

Four-sided column encasement - single layer

2

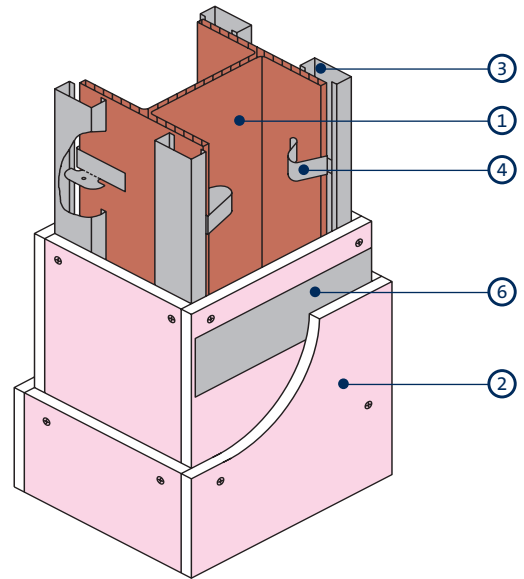

Four-sided column encasement - double layer

3

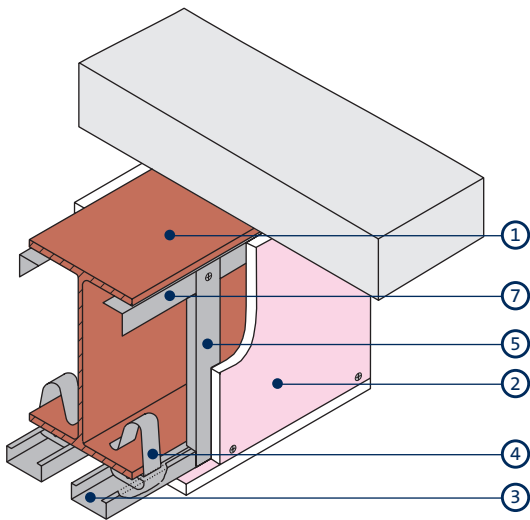

Three-sided beam encasement - single layer

4

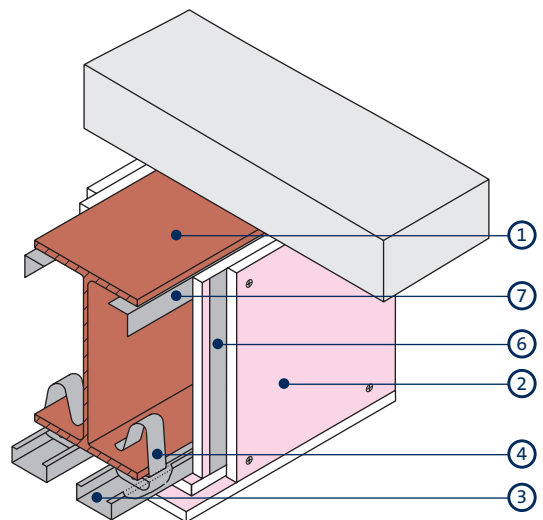

Three-sided beam encasement - double layer

- 1 Structural steel
- 2 Gyproc FireLine or Glasroc boards
- 3 Gypframe GL1 Lining Channel
- 4 Gypframe GL10 Gyplyner Steel Framing Clip

- 5 Gypframe GL1 Lining Channel nogging or Gypframe GFT1 Fixing 'T' at board joints
- 6 Gypframe GFS1 Fixing Strap at board joints
- 7 Gypframe GA2 Steel Angle

5

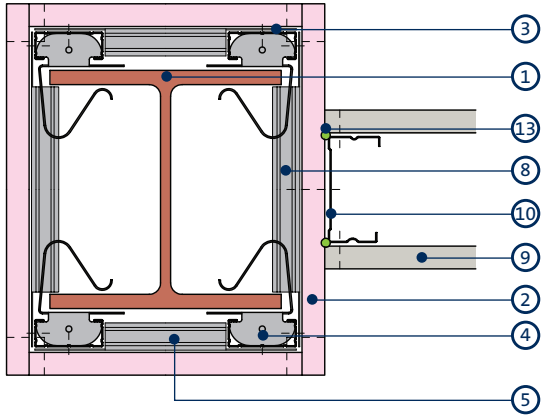

Column encasement and partition junction

6

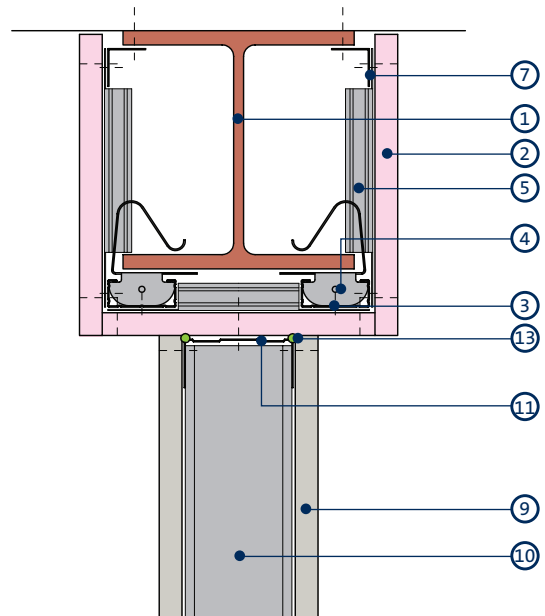

Beam encasement and partition junction

7

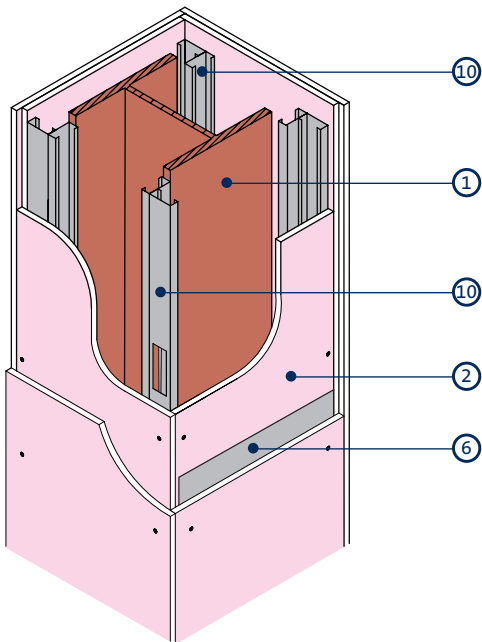

Boxing out for columns up to 600mm wide using Gyplyner iw

8

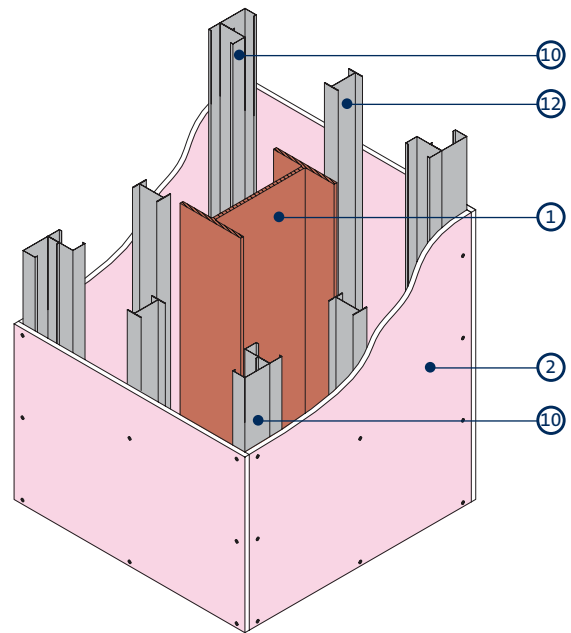

Boxing out for columns over 600mm wide using Gyplyner iw

- 1 Structural steel
- 2 Gyproc FireLine or Glasroc boards
- 3 Gypframe GL1 Lining Channel
- 4 Gypframe GL10 Gyplyner Steel Framing Clip
- 5 Gypframe GL1 Lining Channel nogging or Gypframe GFT1 Fixing 'T' at board joints
- 6 Gypframe GFS1 Fixing Strap at board joints

- 7 Gypframe GA2 Steel Angle
- 8 Gypframe GL1 Lining Channel nogging at 600mm centres
- 9 Gyproc plasterboard
- 10 Gypframe 'C' Studs
- 11 Gypframe Folded Edge Standard Floor & Ceiling Channel
- 12 Gypframe 'T' Stud at 600mm centres
- 13 Gyproc Sealant

NB To optimise acoustic performance install Isover insulation within the encasement void.

Gyplyner ENCASE system components

Gypframe metal components



Gypframe 'I' Studs (48 I 50, 60 I 50, 60 I 70, 70 I 50, 70 I 70, 92 I 90, 146 I 80, 146 TI 90 Tabbed)

Enhanced strength stud that allows for increased lining height, designed to receive fixing of board. Allows an increase to the overall size of encasement.

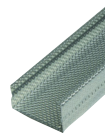

Gypframe 'C' Studs (48 S 50, 60 S 50, 70 S 50, 70 S 60, 95 S 50, 92 S 60, 92 S 10, 146 S 50)

Vertical stud providing acoustic and structural performances designed to receive fixing of board. Allows an increase to the overall size of encasement.



Gypframe GL1 Lining Channel

Main support channel to receive fixing of board.



Gypframe GL3 Channel Connector

For joining two sections of Gypframe GL1 Lining Channel.



Gypframe GL10 Gyplyner Steel Framing Clip

For connecting GL1 Lining Channel to flanges of structural steel.



Gypframe GA2 Steel Angle

Steel angle providing framing stability and board support.

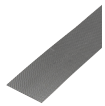

Gypframe GFS1 Fixing Strap

Used to support horizontal board joints.



Gypframe GFT1 Fixing 'T'

Used to support horizontal board joints.

Board products



Gyproc FireLine¹

Gypsum plasterboard with fire resistant additives.



Glasroc F FIRECASE

Non-combustible glass-reinforced gypsum board giving up to 180 minutes fire protection.



Gyproc DuraLine¹

Gypsum plasterboard with fire resistant additives and a high density core for enhanced sound insulation and impact resistance performance.



Glasroc F MULTIBOARD

Non-combustible glass-reinforced gypsum board.

¹ Also available in a Moisture Resistant (MR) version. MR boards are specified in intermittent wet use areas.

Fixing products



Gyproc Drywall Screws

Corrosion resistant self-tapping steel screws for fixing board-to-timber and board-to-metal framing less than 0.8mm thick.



Gyproc Wafer Head Drywall Screws

Corrosion resistant self-tapping steel screws for fixing metal to metal framing less than 0.8mm thick.



Gyproc Collated Drywall Screws

Corrosion resistant self-tapping steel screws for fixing board-to-timber and board-to-metal framing less than 0.8mm thick.



Glasroc F FIRECASE Screws

Corrosion resistant self-tapping steel screws with unique head design that countersinks itself into Glasroc F FIRECASE board to metal framing.

Gypliyner ENCASE system components (continued)

Plasterboard accessories



Gyproc Jointing Materials

Jointing compounds, ready mixes and adhesives for reinforcement and finishing of board joints.



Gyproc Drywall Primer

Used to prepare for painting.
Tub contents 10 litre

Finishing products



Gyproc Skimcoat

To provide a plaster skim finish on most common backgrounds including undercoat plasters and plasterboard.



Gyproc Carlite Finish

To provide a plaster skim finish on most common backgrounds including undercoat plasters and plasterboard.



Gyproc Carlite Ultra Finish

Offers all the benefits of Gyproc Skimcoat and Gyproc Carlite Finish with a reduced set time of 90-120mins, making it ideal for smaller jobs.



Plaster accessories

Designed for the reinforcement and finishing of board joints before plaster skimming.



Handy hint

- Looking for additional performance? Consider the use of Gyproc DuraLine in lieu of Gyproc FireLine to reduce unplanned maintenance as this board provides additional impact performance.
- If you require 180 minutes fire protection, double layer Glasroc F FIRECASE provides the ideal solution.

Gyplyner ENCASE installation overview

This is intended to be a basic description of how the system is built.
For detailed installation guidance refer to the Gyproc Installation Guide.



Four-sided protection to steel columns, Gyplyner GL10 Gyplyner Steel Framing Clips are friction-fitted onto the column / beam flanges at 800mm centres.



Gypframe GL1 Lining Channels are located over the clips to form the steel framework.



For two or three-sided beams or columns Gypframe GA2 Steel Angle is located to both sides of the wall / soffit flange and secured using appropriate fixings.



Boards are cut to width and fixed to all framing members using Gyproc Drywall Screws.



Board-end joints are backed using horizontal noggings formed from an appropriate Gypframe component: Gypframe GL1 Lining Channel, Gypframe GFS1 Fixing Strap or Gypframe GFT1 Fixing 'T'.



Additional information

For full installation details, refer to the **Gyproc Installation Guide**, available to download from gyproc.ie